

GTM CORPORATION

ISSUED DATE :2005/04/14
REVISED DATE :2005/10/04B

GSS1120 Dual 1A Low Dropout Positive Regulator

Description

The GSC1120 series are low dropout positive regulator with minimum of 1A output current capability. The product is specifically designed to provide well-regulated supply for low voltage IC applications such as high speed bus termination and low current 3.3V/2.5V or 3.3V/1.8V logic supply. GSC1120 series and guaranteed to have <1.3V dropout at full load current making it ideal to provide well regulated outputs dual channels with up to 18V input supply.

Features

- 1.3V maximum dropout at full load current
- Fast transient response
- Output current limiting for each channel
- Built-in thermal shutdown each channel
- Good noise rejection
- Dual output A: ch1=3.3V, ch2=2.5V
B: ch1=3.3V, ch2=1.8V

Applications

- PC peripheral
- Communication

Package Dimensions

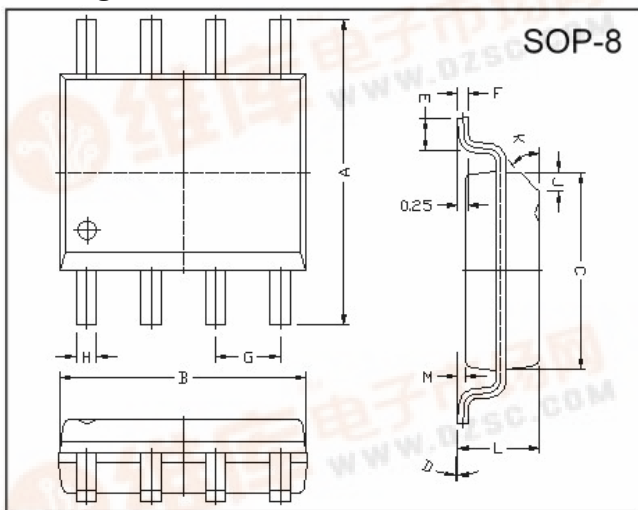

Pin Descriptions

Name	Function
GND 1/2	Ground
3.3V (Vout1)	The output of the regulator. A minimum of 10μF capacitor (0.15Ω ≤ ESR ≤ 20Ω) must be connected from this pin to ground to insure stability.
2.5V/1.8V (Vout2)	The output of the regulator. A minimum of 10μF capacitor (0.15Ω ≤ ESR ≤ 20Ω) must be connected from this pin to ground to insure stability.
Vin 1/2	The input pin of regulator. Typical a large storage capacitor (0.15Ω ≤ ESR ≤ 20Ω) is connected from this pin to ground.

Marking :

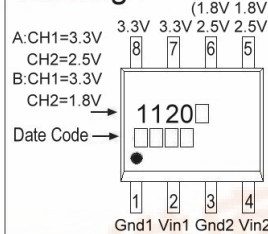

REF.	Millimeter		REF.	Millimeter	
	Min.	Max.		Min.	Max.
A	5.80	6.20	M	0.10	0.25
B	4.80	5.00	H	0.35	0.49
C	3.80	4.00	L	1.35	1.75
D	0°	8°	J	0.375 REF.	
E	0.40	0.90	K	45°	
F	0.19	0.25	G	1.27 TYP.	

Typical Circuit

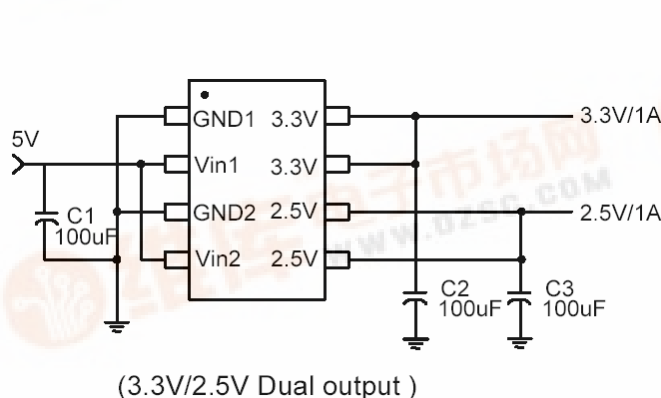

Block Diagram

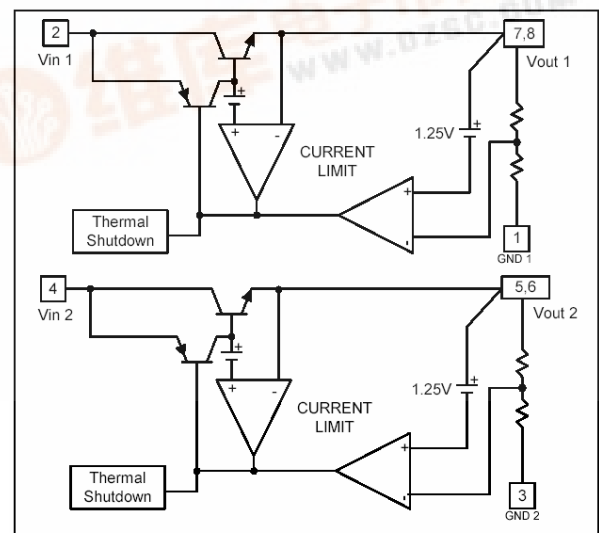

Absolute Maximum Ratings

Symbol	Parameter	Ratings	Unit
V _{IN}	DC Supply Voltage	-0.3 to 12	V
P _D	Power Dissipation	Internally Limited	
T _{ST}	Storage Temperature	-65 ~ + 150	°C
T _{OP}	Operating Junction Temperature Range	0 ~ + 150	°C

Electrical Characteristics

Parameter	Conditions	Min	Typ	Max	Unit	
Output Voltage	GSC1120A(B)-V _{OUT1}	I _o =10mA, T _J =25°C, 4.8V ≤ V _{IN} ≤ 12V	3.235	3.300	3.365	V
	GSC1120A-V _{OUT2}	I _o =10mA, T _J =25°C, 4.0V ≤ V _{IN} ≤ 12V	2.450	2.500	2.550	V
	GSC1120B-V _{OUT2}	I _o =10mA, T _J =25°C, 4.0V ≤ V _{IN} ≤ 12V	1.764	1.800	1.836	V
Line Regulation	I _o =10mA, V _{OUT} +1.5V < V _{IN} < 12V, T _J =25°C	-	-	0.2	%	
Load Regulation	GSC1120-V _{OUT1}	V _{IN} =5V, 0mA < I _o < 1A, T _J =25°C (Note 1,2)	-	26	33	mV
	GSC1120-V _{OUT2}	V _{IN} =4V, 0mA < I _o < 1A, T _J =25°C (Note 1,2)	-	20	25	mV
Dropout Voltage (V _{IN} -V _{OUT})	I _o =1A, ΔV _{OUT} =0.1%V _{OUT}	-	1.3	1.4	V	
Current Limit	V _{IN} -V _{OUT} =5V	1.1	-	-	A	
Minimum Load Current	0°C ≤ T _J ≤ 125°C (Note 3)	-	5	10	mA	
Thermal Regulation	T _A =25°C, 30ms pulse	-	0.008	0.04	%/W	
Ripple Rejection	F=120HZ, C _{OUT} =25uF Tantalum, I _{OUT} =1A	-	60	70	dB	
Temperature Stability	I _o =10mA	-	0.5	-	%	
θ _{JA} Thermal Resistance Junction-to-Ambient(No heat sink ;No air flow)	SOP8: Control Circuitry/Power Transistor (Note 4) CH1 or CH2 only CH1 & CH2 and PD1=PD2	-	50 45	-	°C/w	
θ _{JC} Thermal Resistance Junction-to-Case	SOP8: Control Circuitry/Power Transistor (Note 4) CH1 or CH2 only CH1 & CH2 and PD1=PD2	-	20 12	-	°C/w	

Note 1: See thermal regulation specifications for changes in output voltage due to heating effects. Line and load regulation are measured at a constant junction temperature by low duty cycle pulse testing. Load regulation is measured at the output lead =1/18" from the package.

Note 2: Line and load regulation are guaranteed up to the maximum power dissipation of 15W. Power dissipation is determined by the input/output differentially and the output current. Guaranteed maximum power dissipation will not be available over the full input/output range.

Note 3: Quiescent current is defined as the minimum output current that requires maintaining regulation. At 12V input/output differential the device is guaranteed to regulate if the output current is greater than 10mA.

Note 4: V_{out1} and V_{out2} are connected to the PCB copper area 5.5mm*5.5mm separately. If you need large PD or lower T_c & T_J, please connect to the large copper area >> 5.5mm*5.5mm (like 10mm*10mm).

Typical Performance Characteristics

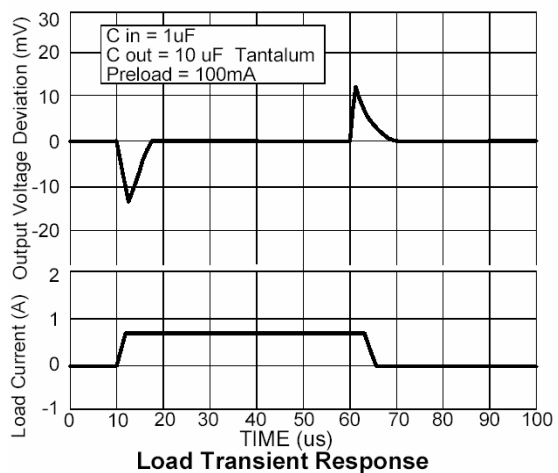
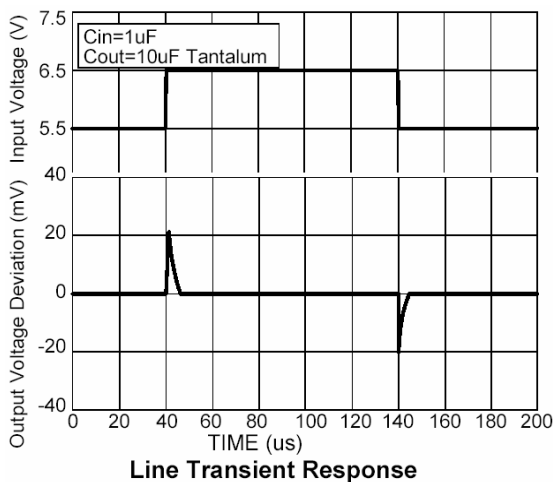
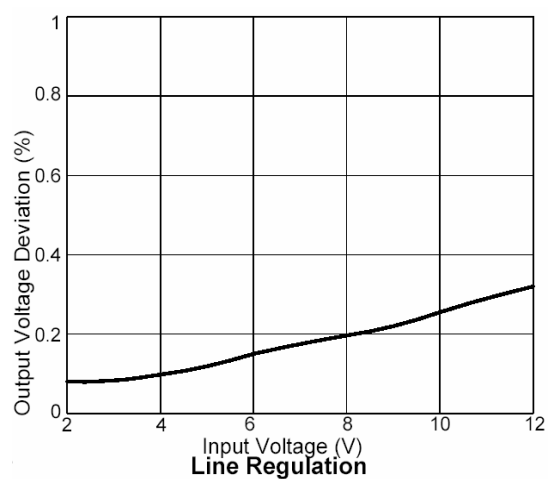
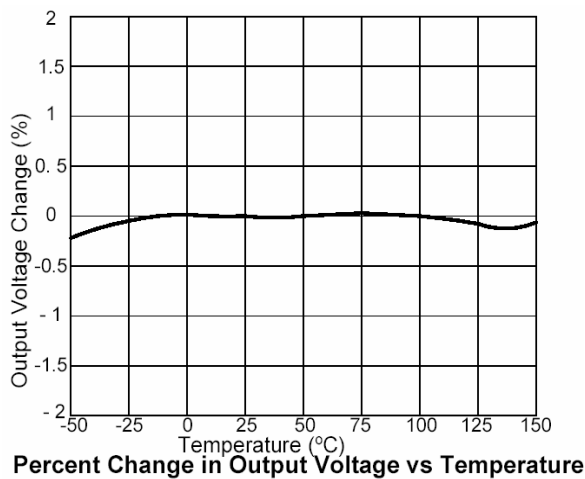
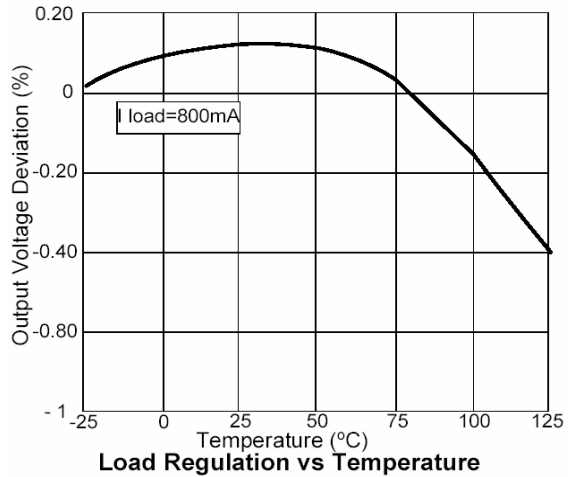
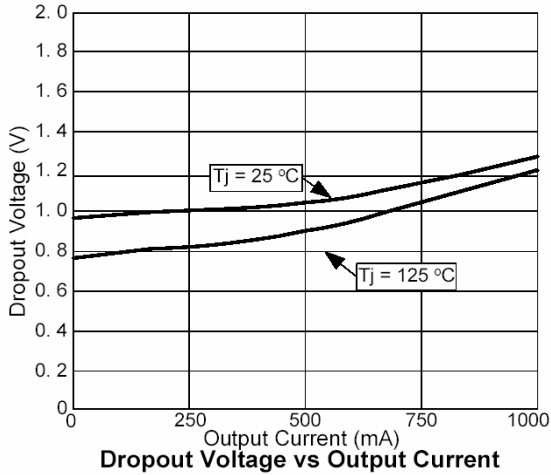

Important Notice:

- All rights are reserved. Reproduction in whole or in part is prohibited without the prior written approval of GTM.
- GTM reserves the right to make changes to its products without notice.
- GTM semiconductor products are not warranted to be suitable for use in life-support Applications, or systems.
- GTM assumes no liability for any consequence of customer product design, infringement of patents, or application assistance.

Head Office And Factory:

Taiwan: No. 17-1 Tatung Rd. Fu Kou Hsin-Chu Industrial Park, Hsin-Chu, Taiwan, R. O. C.
 TEL : 886-3-597-7061 FAX : 886-3-597-9220, 597-0785
 China: (201203) No.255, Jang-Jiang Tsai-Lueng RD. , Pu-Dung-Hsin District, Shang-Hai City, China
 TEL : 86-21-5895-7671 ~ 4 FAX : 86-21-38950165