

Key Features

- SMPTE 292M, SMPTE 344M and SMPTE 259M compliant
- automatic cable equalization
- multi-standard operation from 143Mb/s to 1.485Gb/s
- supports DVB-ASI at 270Mb/s
- manual bypass (useful for low data rates with slow rise/fall times)
- performance optimized for 270Mb/s and 1.485Gb/s
- typical maximum equalized length of Belden 1694A cable: 140m at 1.485Gb/s, 350m at 270Mb/s
- 50Ω differential output (with internal 50Ω pull-ups)
- Pb-free and RoHS Compliant

Key Specifications

- cable length indicator for SMPTE 259M inputs
- output mute based on max cable length adjust or manual override
- single 3.3V power supply operation
- operating temperature range: 0°C to +70°C

Applications

- SMPTE 292M, SMPTE 344M and SMPTE 259M Coaxial Cable Serial Digital Interfaces

Description

The GS1524 is a second-generation high-speed bipolar integrated circuit designed to equalize and restore signals received over 75Ω co-axial cable at data rates from 143Mb/s up to 1.485Gb/s. The GS1524 is designed to support SMPTE 292M, SMPTE 344M and SMPTE 259M, and is optimized for performance at 270Mb/s and 1.485Gb/s.

The GS1524 features DC restoration to compensate for the DC content of SMPTE pathological test patterns. The GS1524 also incorporates a Cable Length Indicator (CLI) that provides an indication of the amount of cable being equalized for data rates up to 360Mb/s.

A voltage programmable mute threshold (MCLADJ) is included to allow muting of the GS1524 output when an approximate selected cable length is reached for SMPTE 259M signals. This feature allows the GS1524 to distinguish between low amplitude SD-SDI signals and noise at the input of the device. The $\overline{\text{CD}}/\text{MUTE}$ pin provides an indication of the GS1524 mute status in addition to functioning as a mute control input. The SD outputs of the GS1524 may be forced to a mute state by applying a voltage to the $\overline{\text{CD}}/\text{MUTE}$ pin.

Power consumption is typically 265mW using a 3.3V power supply.

This component and all homogeneous subcomponents are RoHS compliant.

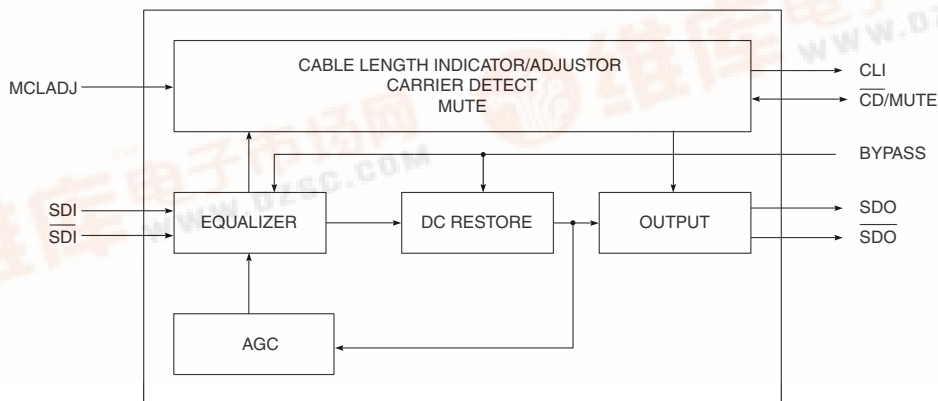

Functional Block Diagram



Contents

Key Features.....	1
Key Specifications.....	1
Applications.....	1
Description	1
1. Electrical Characteristics.....	3
1.1 Absolute Maximum Ratings	3
1.2 DC Electrical Characteristics	3
1.3 AC Electrical Characteristics	4
2. Pin Out.....	6
2.1 Pin Connections	6
2.2 Pin Descriptions	6
3. Input/Output Circuits	8
4. Typical Performance Curves.....	10
5. Detailed Description	14
6. Cable Length Indication/Carrier Detect/Mute.....	15
7. Application Information.....	16
7.1 PCB Layout	16
7.2 Typical Application Circuit	16
8. Package dimensions	17
8.1 Ordering Information	17
9. Revision History	18

1. Electrical Characteristics

1.1 Absolute Maximum Ratings

Parameter	Value
Supply Voltage	-0.5V to +3.6V _{DC}
Input ESD Voltage	500V
Storage Temperature Range	-50°C < T _s < 125°C
Input Voltage Range (any input)	-0.3 to (V _{CC} + 0.3)V
Operating Temperature Range	0°C to 70°C
Power Dissipation	300mW
Lead Temperature (soldering, 10 sec.)	260°C

1.2 DC Electrical Characteristics

Table 1-1: DC Electrical Characteristics

V_{DD} = 3.3V, T_A = 0°C to 70°C, unless otherwise shown

Parameter	Conditions	Symbol	Min	Typ	Max	Units	Notes	Test Levels
Supply Voltage	–	V _{CC}	3.135	3.3	3.465	V	± 5%	1
Power Consumption	T _A =25°C	P _D	–	265	–	mW	–	5
Supply Current	T _A =25°C	I _S	–	80	–	mA	–	1
Output Common Mode Voltage	T _A =25°C	V _{CMOUT}	–	V _{CC} - ΔV _{SDO} /2	–	V	–	7
Input Common Mode Voltage	T _A =25°C	V _{CMIN}	–	1.75	–	V	–	10
CLI DC Voltage (0m)	T _A =25°C	–	–	2.5	–	V	–	1
CLI DC Voltage (no signal)	T _A =25°C	–	–	1.9	–	V	–	7
Floating MCLADJ DC Voltage	T _A =25°C	–	–	1.3	–	V	–	7
MCLADJ Range	T _A =25°C	–	–	0.69	–	V	–	7
CD/Mute Output Voltage	Carrier not present	V _{CD/Mute(OH)}	2.6	–	–	V	–	1
	Carrier present	V _{CD/Mute(OL)}	–	–	1.2	–	–	1

Table 1-1: DC Electrical Characteristics

V_{DD} = 3.3V, T_A = 0°C to 70°C, unless otherwise shown

Parameter	Conditions	Symbol	Min	Typ	Max	Units	Notes	Test Levels
CD/Mute Input Voltage Required to Force Outputs to Mute	Min to Mute	V _{CD/Mute}	3.0	–	–	V	–	7
CD/Mute Input Voltage Required to Force Active	Max to Activate	V _{CD/Mute}	–	–	2.0	V	–	7

TEST LEVELS

1. Production test at room temperature and nominal supply voltage with guardbands for supply and temperature ranges.
2. Production test at room temperature and nominal supply voltage with guardbands for supply and temperature ranges using correlated test.
3. Production test at room temperature and nominal supply voltage.
4. QA sample test.
5. Calculated result based on Level 1, 2, or 3.
6. Not tested. Guaranteed by design simulations.
7. Not tested. Based on characterization of nominal parts.
8. Not tested. Based on existing design/characterization data of similar product.
9. Indirect test.
10. Wafer Probe

1.3 AC Electrical Characteristics

Table 1-2: AC Electrical Characteristics

V_{DD} = 3.3V, T_A = 0°C to 70°C, unless otherwise shown

Parameter	Conditions	Symbol	Min	Typ	Max	Units	Notes	Test Levels
Serial input data rate	–	–	143	–	1485	Mb/s	–	6
Input Voltage Swing	T _A = 25°C, differential	ΔV _{SDI}	720	800	950	mV _{p-p}	0m cable length	1
Output Voltage Swing	50Ω load, T _A = 25°C, differential	ΔV _{SDO}	–	750	–	mV _{p-p}	–	1
Maximum equalized cable length	270Mb/s, Belden 1694A, 0.2UI output jitter	–	–	350	–	m	Equalizer Pathological	7
	270Mb/s, Belden 8281 0.2UI output jitter	–	–	280	–	m	Equalizer Pathological	1
	1.485Gb/s, Belden 1694A 0.25UI output jitter	–	–	140	–	m	Equalizer Pathological	7
	1.485Gb/s, Belden 8281 0.25UI output jitter	–	–	100	–	m	Equalizer Pathological	1
Output Rise/Fall time	20% - 80%	–	–	80	220	ps	–	1
Mismatch in rise/fall time	–	–	–	–	30	ps	–	1

Table 1-2: AC Electrical Characteristics

V_{DD} = 3.3V, T_A = 0°C to 70°C, unless otherwise shown

Parameter	Conditions	Symbol	Min	Typ	Max	Units	Notes	Test Levels
Duty cycle distortion	–	–	–	–	30	ps	–	1
Overshoot	–	–	–	–	10	%	–	1
Input Return Loss	–	–	15	–	–	dB	1	7
Input Resistance	single ended	–	–	1.64	–	kΩ	–	6
Input Capacitance	single ended	–	–	1	–	pF	–	6
Output Resistance	single ended	–	–	50	–	Ω	–	6

TEST LEVELS:

1. Production test at room temperature and nominal supply voltage with guardbands for supply and temperature ranges.
2. Production test at room temperature and nominal supply voltage with guardbands for supply and temperature ranges using correlated test.
3. Production test at room temperature and nominal supply voltage.
4. QA sample test.
5. Calculated result based on Level 1, 2, or 3.
6. Not tested. Guaranteed by design simulations.
7. Not tested. Based on characterization of nominal parts.
8. Not tested. Based on existing design/characterization data of similar product.
9. Indirect test.

NOTES:

1. Tested on CB1524 board from 5MHz to 2GHz.

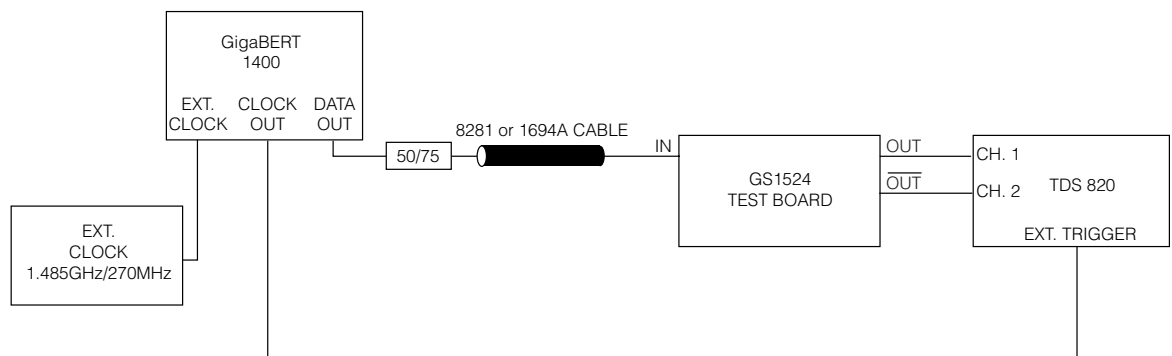

Figure 1-1: Test Circuit

2. Pin Out

2.1 Pin Connections

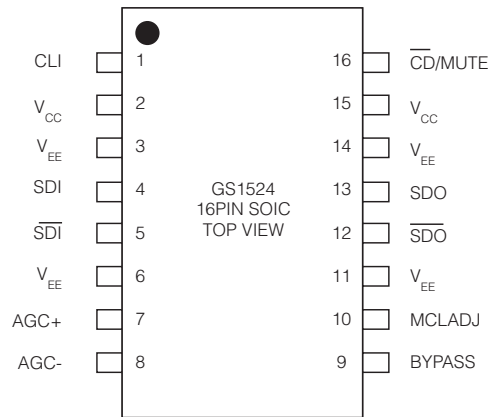

Figure 2-1: 16 PIN SOIC

2.2 Pin Descriptions

Table 2-1: Pin Descriptions

Pin Number	Name	Type	Description
1	CLI	ANALOG OUTPUT	CABLE LENGTH INDICATOR. An analog voltage proportional to the cable length connected to the Serial digital input. Note: CLI is recommended for data rates up to 360Mb/s only.
4,5	SDI, $\overline{\text{SDI}}$	INPUT	Serial digital differential input.
7,8	AGC+, AGC-	PASSIVE INPUT	External AGC capacitor. Should be set to 1 μ F
9	BYPASS	LOGIC INPUT	Forces the Equalizing and DC RESTORE stages into bypass mode when HIGH. No equalization occurs in this mode.
10	MCLADJ	ANALOG INPUT	MAXIMUM CABLE LENGTH ADJUST. Adjusts the approximate maximum amount of cable to be equalized (from 0m to the maximum cable length). The output is muted (latched to the last state) when the maximum cable length is achieved. Note: MCLADJ is recommended for data rates up to 360Mb/s
12, 13	$\overline{\text{SDO}}$, SDO	PECL OUTPUT	Equalized serial digital differential output.

Table 2-1: Pin Descriptions

16	$\overline{\text{CD/MUTE}}$	BIDIRECTIONAL	MUTE INDICATOR-CONTROL/ CARRIER DETECT. OUTPUT: the output voltage drops to below 1.2V when the carrier is present and the data outputs are active. INPUT: if the $\overline{\text{CD/MUTE}}$ pin is tied to ground, the <u>data</u> output will never mute and the MCLADJ setting is overwritten. If the $\overline{\text{CD/MUTE}}$ pin is tied to VCC, the data outputs will always mute and the MCLADJ setting is overwritten. Note: $\overline{\text{CD/MUTE}}$ is not functional in BYPASS mode.
3, 6, 11, 14	V_{EE}	POWER	Most negative power supply connection. Connect to ground.
2, 15	V_{CC}	POWER	Most positive power supply connection. Connect to +3.3V.

3. Input/Output Circuits

All resistors in ohms, all capacitors in farads, unless otherwise shown.

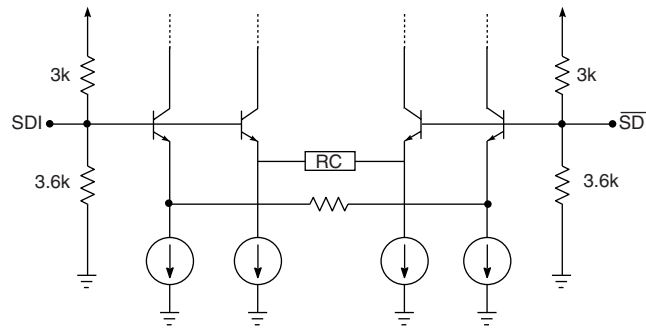

Figure 3-1: Input Equivalent Circuit

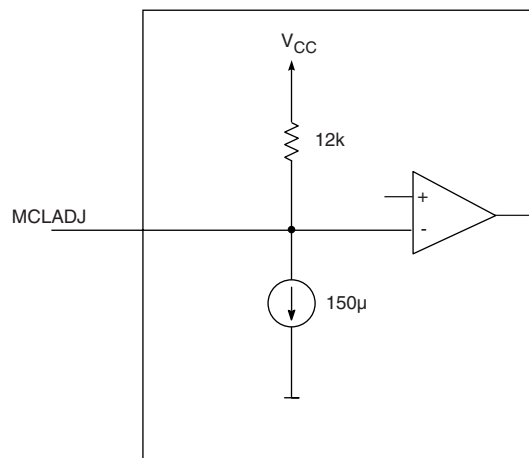

Figure 3-2: MCLADJ Equivalent Circuit

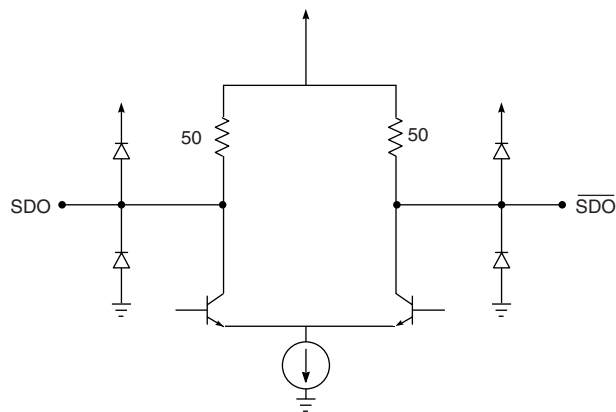

Figure 3-3: Output Circuit

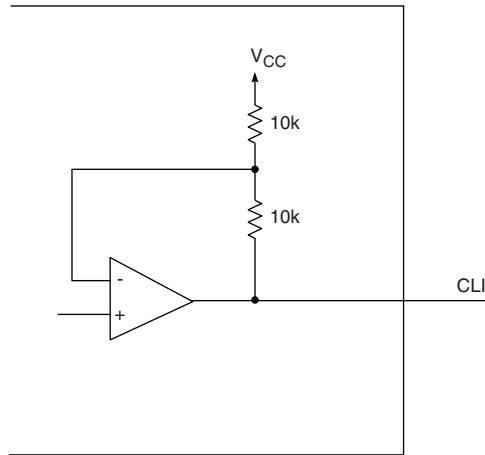

Figure 3-4: CLI Output Circuit

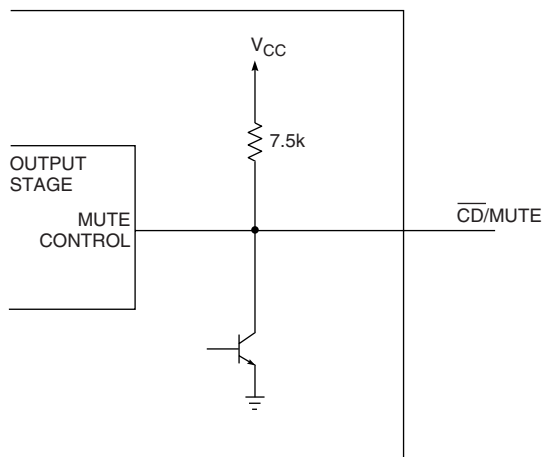

Figure 3-5: \overline{CD} /Mute Circuit

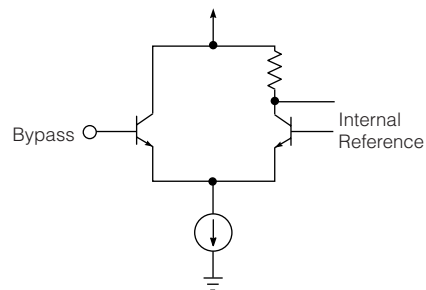

Figure 3-6: Bypass Circuit

4. Typical Performance Curves

(unless otherwise shown, $V_{CC} = 3.3V$, $T_A = 25^{\circ}C$)

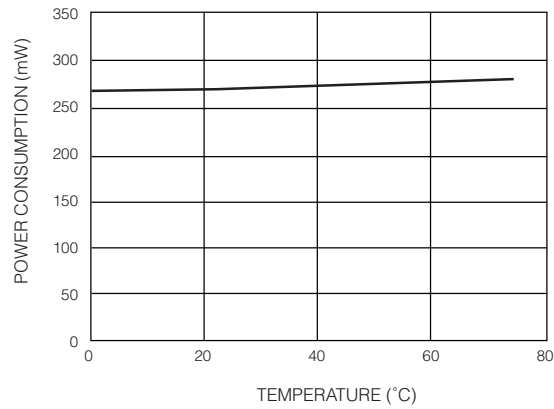

Figure 4-1: Power Consumption

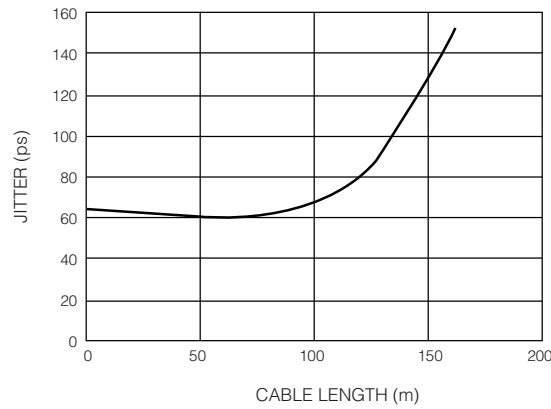

Figure 4-2: Typical Peak to Peak Jitter, PRN 2²³-1, Belden 1694A, 1.485 Gb/s

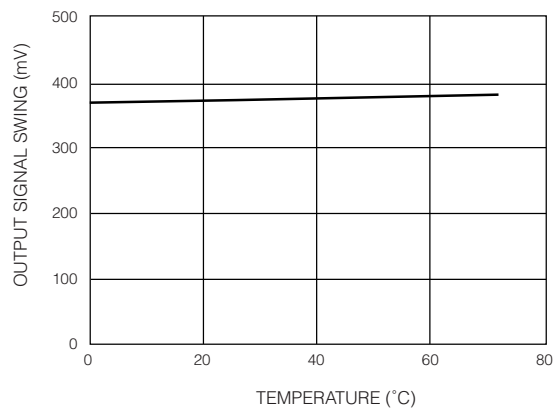

Figure 4-3: Output Signal Swing, p-p, Single Ended

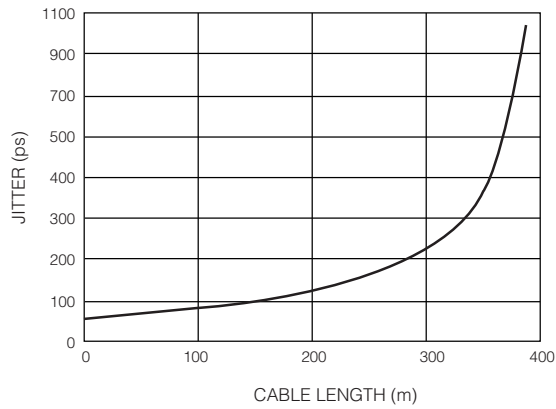

Figure 4-4: Typical Peak to Peak Jitter, PRN 223-1, Belden 1694A, 270Mb/s

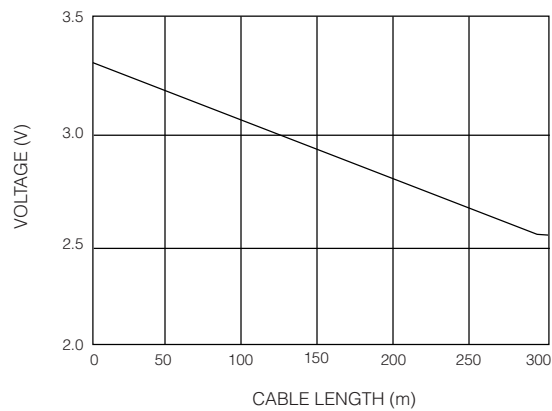

Figure 4-5: MCLADJ Input Voltage vs 1694A Cable Length, 270Mb/s

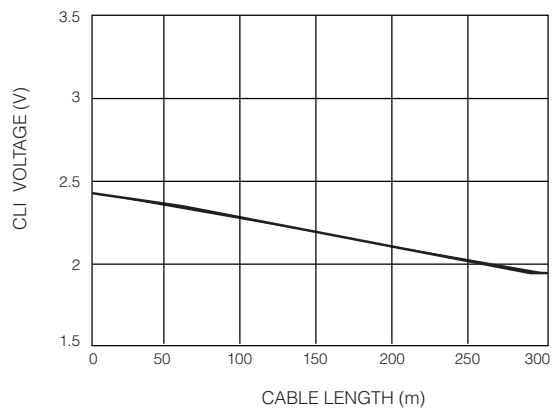

Figure 4-6: CLI Voltage vs. Belden 8281 Cable Length, 270Mb/s

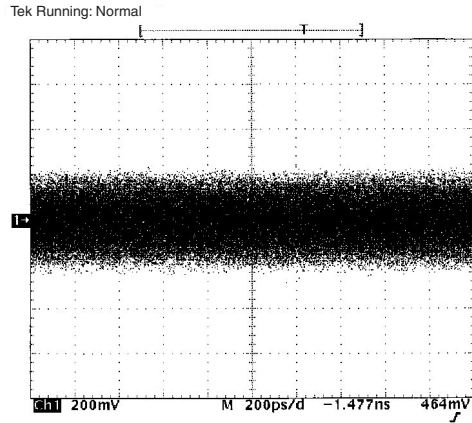

Figure 4-7: Input 100m (Belden 8281), 1.485Gb/s

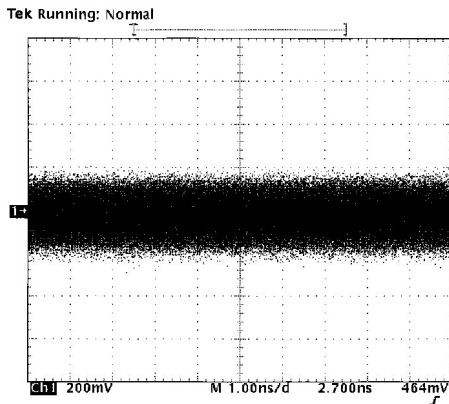

Figure 4-8: Input 280m (Belden 8281), 270Mb/s

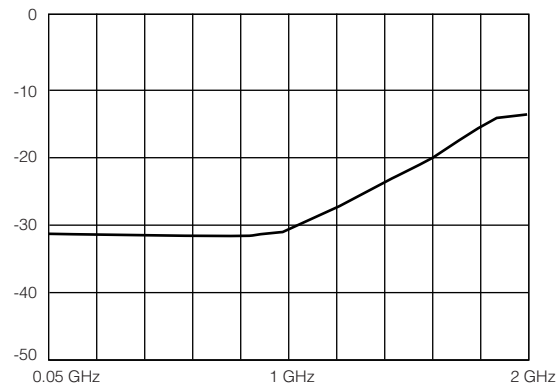

Figure 4-9: Input Return Loss using CB1524 Board

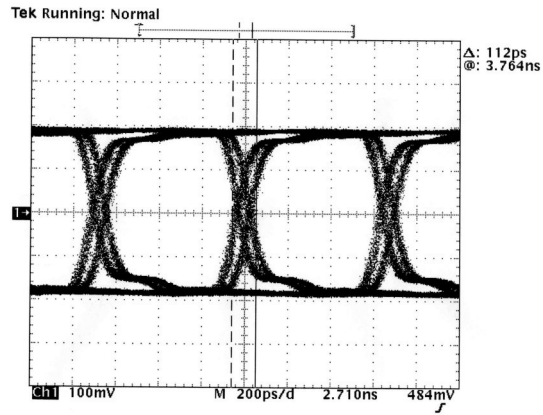

Figure 4-10: Fig. 17 Output 100m (Belden 8281), 1.485Gb/s

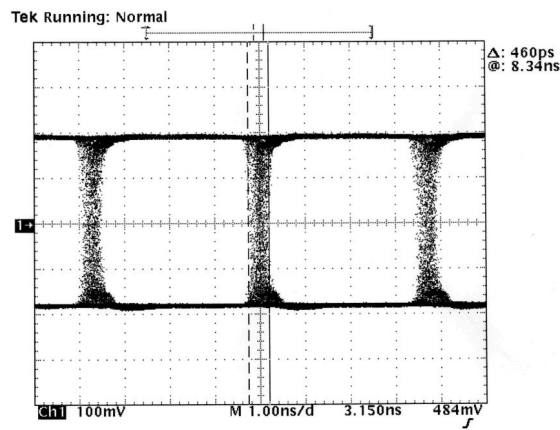

Figure 4-11: Output 280m (Belden 8281), 270Mb/s

5. Detailed Description

The GS1524 is a high speed bipolar IC designed to equalize both HD and SD serial digital signals. The device can typically equalize greater than 140 meters of Belden 1694A cable at 1.485Gb/s and 350m at 270Mb/s. Powered from a single +3.3V or -3.3V power supply, the device consumes approximately 265mW of power.

The serial data signal may be connected to the input pins (SDI/ $\overline{\text{SDI}}$) in either a differential or single ended configuration. AC coupling of the inputs is recommended, as the SDI and $\overline{\text{SDI}}$ inputs are internally biased at approximately 1.8V. The input signal passes through a variable gain equalizing stage whose frequency response closely matches the inverse of the cable loss characteristic. In addition, the variation of the frequency response with control voltage imitates the variation of the inverse cable loss characteristic with cable length.

The edge energy of the equalized signal is monitored by a detector circuit which produces an error signal corresponding to the difference between the desired edge energy and the actual edge energy. This error signal is integrated by both an internal and an external AGC filter capacitor providing a steady control voltage for the gain stage. As the frequency response of the gain stage is automatically varied by the application of negative feedback, the edge energy of the equalized signal is kept at a constant level which is representative of the original edge energy at the transmitter. The equalized signal is also DC restored, effectively restoring the logic threshold of the equalized signal to its correct level independent of shifts due to AC coupling. The digital output signals have a nominal voltage of 750mV_{pp} differential, or 375mV_{pp} single ended when terminated with 50Ω as shown in Figure 5-1.

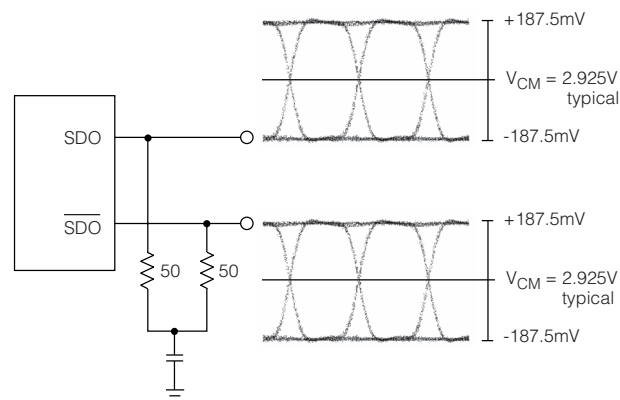

Figure 5-1: Typical Output Voltage Levels

6. Cable Length Indication/Carrier Detect/Mute

For SMPTE 259M inputs the GS1524 incorporates an analog cable length indicator (CLI) output and a programmable threshold output mute (MCLADJ). In addition, a multi-function $\overline{\text{CD}}/\text{MUTE}$ pin allows control of the GS1524 MUTE functionality for both SD and HD inputs.

The voltage output of CLI pin is an approximation of the amount of cable present at the GS1524 input for data rates up to 360Mb/s. The CLI voltage versus cable length (signal strength) is shown in [Figure 4-6](#). With 0m of cable, 800mV input signal levels and at 270Mb/s, the CLI output voltage is approximately 2.5V. As the cable length increases, the CLI voltage decreases providing an approximate correlation between the CLI voltage and cable length.

In applications where there are multiple input channels using the GS1524, it is advantageous to have a programmable mute output to avoid signal crosstalk.

The output of the GS1524 can be muted when the input signal decreases below a selectable input level. The voltage applied to the MCLADJ pin vs input cable length is shown in [Figure 4-5](#). For consistent accurate results this may need to be calibrated for each device. The MCLADJ pin may be left unconnected for applications where output muting is not required. This feature has been designed for use in applications such as routers where signal crosstalk and circuit noise cause the equalizer to output erroneous data when no input signal is present. The use of a Carrier Detect function with a fixed internal reference does not solve this problem since the signal to noise ratio on the circuit board could be significantly less than the default signal detection level set by the on chip reference.

Note: MCLADJ and CLI are only recommended for data rates up to 360Mb/s.

The $\overline{\text{CD}}/\text{Mute}$ pin is a multi-function bidirectional pin that provides the following functions:

Applying a HIGH INPUT to the $\overline{\text{CD}}/\text{Mute}$ pin forces the GS1524 outputs to a muted condition. See the [Table 1-1: DC Electrical Characteristics](#) for voltage levels. In this condition the outputs will be latched to the last logic level present at the output to avoid signal crosstalk.

Applying a LOW INPUT to the $\overline{\text{CD}}/\text{Mute}$ pin will force the GS1524 outputs to remain active regardless of the length of input cable and the voltage applied to the MCLADJ pin. See the [Table 1-1: DC Electrical Characteristics](#) for voltage levels.

When used as an OUTPUT, the $\overline{\text{CD}}/\text{Mute}$ pin will provide an indication of the output mute status. The $\overline{\text{CD}}/\text{Mute}$ voltage will fall to below 1.2V when the carrier is present and the data outputs are active.

Note: The $\overline{\text{CD}}/\text{Mute}$ pin is not functional in BYPASS mode.

7. Application Information

7.1 PCB Layout

Special attention must be paid to component layout when designing serial digital interfaces for HDTV. An FR-4 dielectric can be used, however, controlled impedance transmission lines are required for PCB traces longer than approximately 1cm. Note the following PCB artwork features used to optimize performance:

PCB trace width for HD rate signals is closely matched to SMT component width to minimize reflections due to change in trace impedance.

The PCB ground plane is removed under the GS1524 input components to minimize parasitic capacitance.

The PCB ground plane is removed under the GS1524 output components to minimize parasitic capacitance.

High speed traces are curved to minimize impedance changes.

7.2 Typical Application Circuit

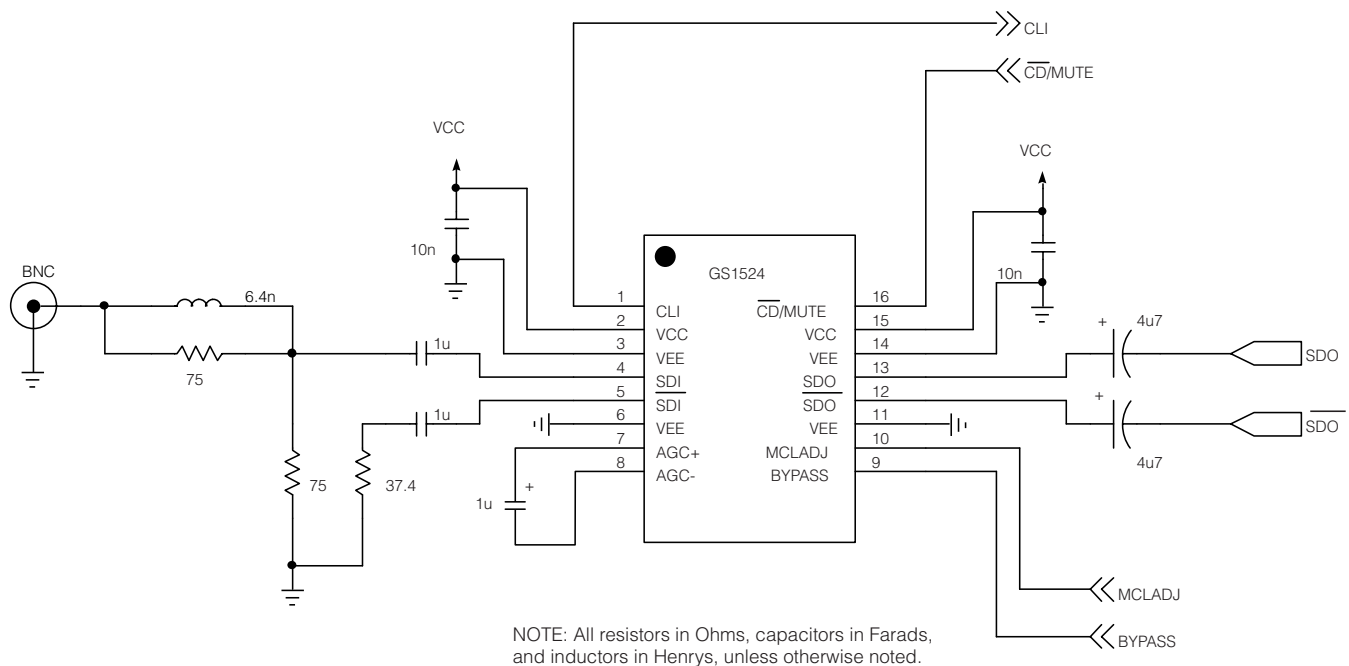

8. Package dimensions

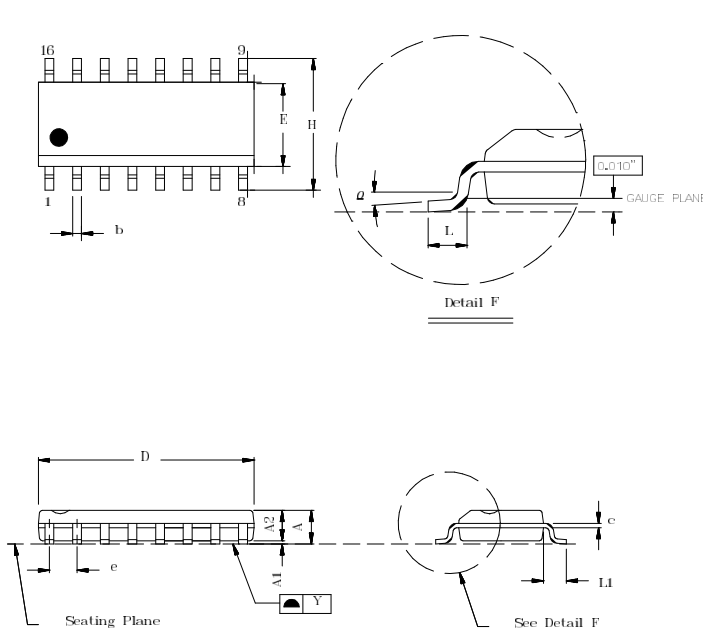

* CONTROLLING DIMENSION: MM

Symbol	MILLIMETER			INCH		
	MIN.	NOM.	MAX.	MIN.	NOM.	MAX.
A	1.35	1.63	1.75	0.053	0.064	0.069
A1	0.10	0.15	0.25	0.004	0.006	0.010
A2	1.30	1.40	1.50	0.051	0.055	0.059
b	0.33	0.41	0.51	0.013	0.016	0.020
c	0.19		0.25	0.007		0.010
D	9.80	9.91	10.01	0.386	0.390	0.394
E	3.80	3.90	4.00	0.150	0.154	0.157
e		1.27			0.50	
H	5.80	6.00	6.20	0.228	0.236	0.244
L	0.40	0.64	1.27	0.016	0.025	0.050
L1		1.07			0.042	
Y			0.10			0.004
Ø	0"		8"	0"		8"

Figure 8-1: 16 PIN SOIC

8.1 Ordering Information

Part Number	Package	Temperature	Pb-Free and RoHS Compliant
GS1524-CKD	16 pin SOIC	0°C to 70°C	No
GS1524-CTD	16 pin SOIC Tape	0°C to 70°C	No
GS1524-CKDE3	16 pin SOIC	0°C to 70°C	Yes
GS1524-CTDE3	16 pin SOIC Tape	0°C to 70°C	Yes

9. Revision History

Version	ECR	Date	Changes and / or Modifications
6	136565	April 2005	Updated 'Green' references to RoHS Compliant.
7	137165	June 2005	Rephrased RoHS compliance statement.

CAUTION

ELECTROSTATIC SENSITIVE DEVICES
DO NOT OPEN PACKAGES OR HANDLE
EXCEPT AT A STATIC-FREE WORKSTATION



DOCUMENT IDENTIFICATION

DATA SHEET

The product is in production. Genum reserves the right to make changes to the product at any time without notice to improve reliability, function or design, in order to provide the best product possible.

GENNUM CORPORATION

Mailing Address: P.O. Box 489, Stn. A, Burlington, Ontario, Canada L7R 3Y3
Shipping Address: 970 Fraser Drive, Burlington, Ontario, Canada L7L 5P5
Tel. +1 (905) 632-2996 Fax. +1 (905) 632-5946

GENNUM JAPAN CORPORATION

Shinjuku Green Tower Building 27F, 6-14-1, Nishi Shinjuku, Shinjuku-ku, Tokyo, 160-0023 Japan
Tel. +81 (03) 3349-5501, Fax. +81 (03) 3349-5505

GENNUM UK LIMITED

25 Long Garden Walk, Farnham, Surrey, England GU9 7HX
Tel. +44 (0)1252 747 000 Fax +44 (0)1252 726 523

Genum Corporation assumes no liability for any errors or omissions in this document, or for the use of the circuits or devices described herein. The sale of the circuit or device described herein does not imply any patent license, and Genum makes no representation that the circuit or device is free from patent infringement.

GENNUM and the G logo are registered trademarks of Genum Corporation.

© Copyright 2001 Genum Corporation. All rights reserved. Printed in Canada.

www.gennum.com