

TQFP, QFP

Commercial Temp

Industrial Temp

64K x 32

2M Synchronous Burst SRAM

150 MHz–66 MHz

9 ns–18 ns

3.3 V V_{DD}

3.3 V and 2.5 V I/O

Features

- \overline{FT} pin for user-configurable flow through or pipeline operation
- Single Cycle Deselect (SCD) operation
- 3.3 V +10%/–5% core power supply
- 2.5 V or 3.3 V I/O supply
- LBO pin for Linear or Interleaved Burst mode
- Internal input resistors on mode pins allow floating mode pins
- Default to Interleaved Pipeline mode
- Byte Write (\overline{BW}) and/or Global Write (\overline{GW}) operation
- Common data inputs and data outputs
- Clock Control, registered, address, data, and control
- Internal self-timed write cycle
- Automatic power-down for portable applications
- JEDEC-standard 100-lead TQFP or QFP package

		-150	-138	-133	-117	-100	-66	Unit
Pipeline 3-1-1-1	tCycle	6.6	7.25	7.5	8.5	10	12.5	ns
	tkQ	3.8	4	4	4.5	5	6	ns
	I _{DD}	270	245	240	210	180	150	mA
Flow Through 2-1-1-1	tCycle	10.5	15	15	15	15	20	ns
	tkQ	9	9.7	10	11	12	18	ns
	I _{DD}	170	120	120	120	120	95	mA

Functional Description

Applications

The GS82032 is a 2,097,152-bit high performance synchronous SRAM with a 2-bit burst address counter. Although of a type originally developed for Level 2 Cache applications supporting high performance CPUs, the device now finds application in synchronous SRAM applications ranging from DSP main store to networking chip set support.

Controls

Addresses, data I/Os, chip enables ($\overline{E1}$, $E2$, $\overline{E3}$), address burst control inputs (\overline{ADSP} , \overline{ADSC} , \overline{ADV}), and write control inputs (\overline{Bx} , \overline{BW} , \overline{GW}) are synchronous and are controlled by a positive-edge-triggered clock input (\overline{CK}). Output enable (\overline{G}) and power down control (\overline{ZZ}) are asynchronous inputs. Burst cycles can be initiated with either \overline{ADSP} or \overline{ADSC} inputs. In Burst mode, subsequent burst addresses are generated internally and are controlled by \overline{ADV} . The burst address counter may be configured to count in either linear or interleave order with the Linear Burst Order (\overline{LBO}) input. The Burst function need not be used. New addresses can be loaded on every cycle with no degradation of chip performance.

Flow Through/Pipeline Reads

The function of the Data Output register can be controlled by the user via the \overline{FT} mode pin/bump (Pin 14 in the TQFP, Bump 1F in the FP-BGA). Holding the \overline{FT} mode pin/bump low, places the RAM in Flow Through mode, causing output data to bypass the Data Output Register. Holding \overline{FT} high places the RAM in Pipeline mode, activating the rising-edge-triggered Data Output Register.

SCD Pipelined Reads

The GS82032 is an SCD (Single Cycle Deselect) pipelined synchronous SRAM. DCD (Dual Cycle Deselect) versions are also available. SCD SRAMs pipeline deselect commands one stage less than read commands. SCD RAMs begin turning off their outputs immediately after the deselect command has been captured in the input registers.

Byte Write and Global Write

Byte write operation is performed by using Byte Write enable (\overline{BW}) input combined with one or more individual byte write signals (\overline{Bx}). In addition, Global Write (\overline{GW}) is available for writing all bytes at one time, regardless of the byte write control inputs.

Sleep Mode

Low power (Sleep mode) is attained through the assertion (High) of the \overline{ZZ} signal, or by stopping the clock (\overline{CK}). Memory data is retained during Sleep mode.

Core and Interface Voltages

The GS82032 operates on a 3.3 V power supply and all inputs/outputs are 3.3 V- and 2.5 V-compatible. Separate output power (V_{DDQ}) pins are used to decouple output noise from the internal circuit.

GS82032 100-Pin TQFP and QFP Pinout

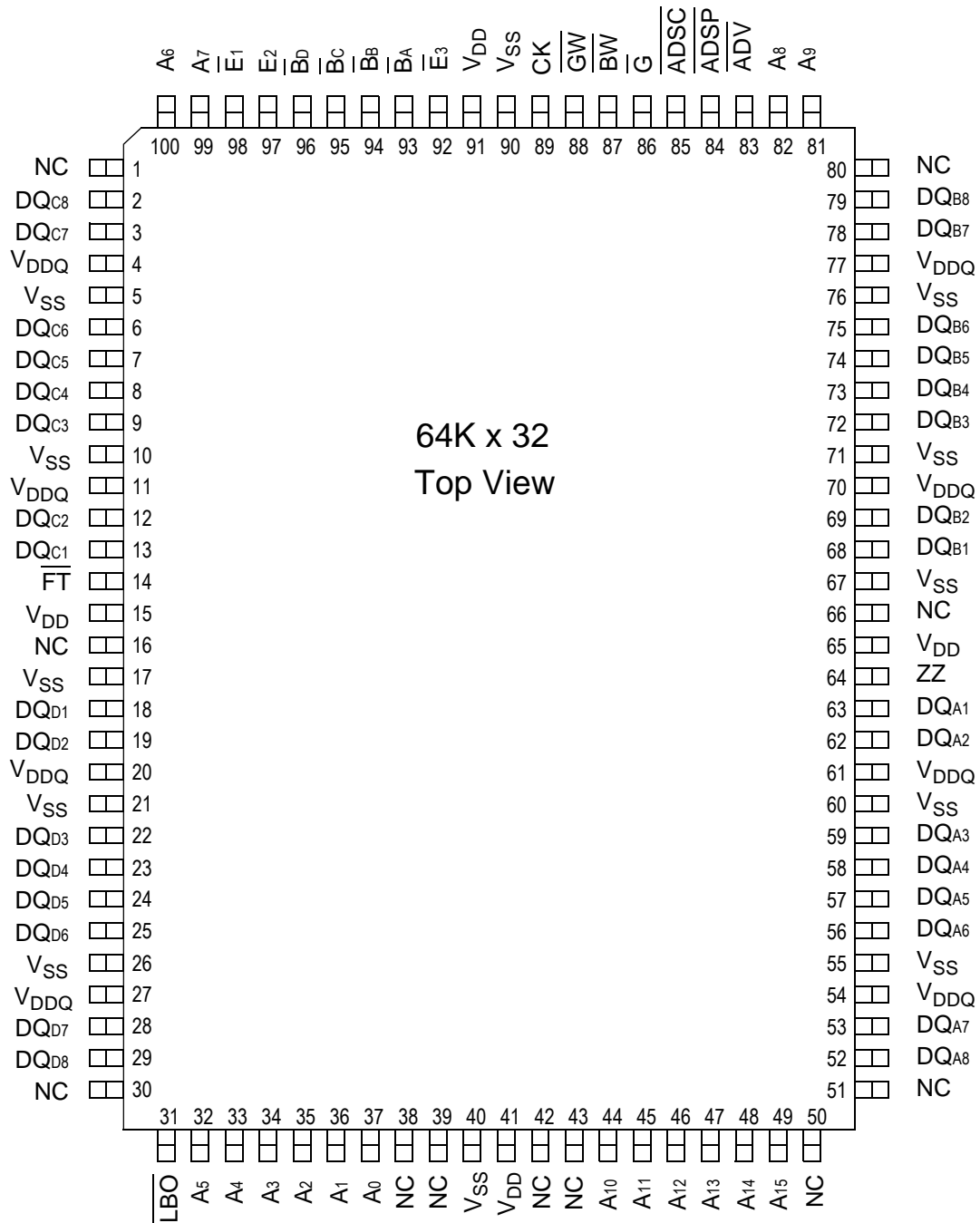

TQFP Pin Description

Pin Location	Symbol	Type	Description
37, 36	A ₀ , A ₁	I	Address field LSBs and Address Counter preset Inputs
35, 34, 33, 32, 100, 99, 82, 81, 44, 45, 46, 47, 48, 49	A ₂ –A ₁₅	I	Address Inputs
52, 53, 56, 57, 58, 59, 62, 63 68, 69, 72, 73, 74, 75, 78, 79 2, 3, 6, 7, 8, 9, 12, 13 18, 19, 22, 23, 24, 25, 28, 29	DQ _{A1} –DQ _{A8} DQ _{B1} –DQ _{B8} DQ _{C1} –DQ _{C8} DQ _{D1} –DQ _{D8}	I/O	Data Input and Output pins
16, 38, 39, 42, 43, 66, 50, 51, 80, 1, 30	NC		No Connect
87	BW	I	Byte Write—Writes all enabled bytes; active low
93, 94	B _A , B _B	I	Byte Write Enable for DQ _A , DQ _B Data I/Os; active low
95, 96	B _C , B _D	I	Byte Write Enable for DQ _C , DQ _D Data I/Os; active low
89	CK	I	Clock Input Signal; active high
88	GW	I	Global Write Enable—Writes all bytes; active low
98, 92	E ₁ , E ₃	I	Chip Enable; active low
97	E ₂	I	Chip Enable; active high
86	G	I	Output Enable; active low
83	ADV	I	Burst address counter advance enable; active low
84, 85	ADSP, ADSC	I	Address Strobe (Processor, Cache Controller); active low
64	ZZ	I	Sleep Mode control; active high
14	FT	I	Flow Through or Pipeline mode; active low
31	LBO	I	Linear Burst Order mode; active low
15, 41, 65, 91	V _{DD}	I	Core power supply
5, 10, 17, 21, 26, 40, 55, 60, 67, 71, 76, 90	V _{SS}	I	I/O and Core Ground
4, 11, 20, 27, 54, 61, 70, 77	V _{DDQ}	I	Output driver power supply

GS82032 Block Diagram

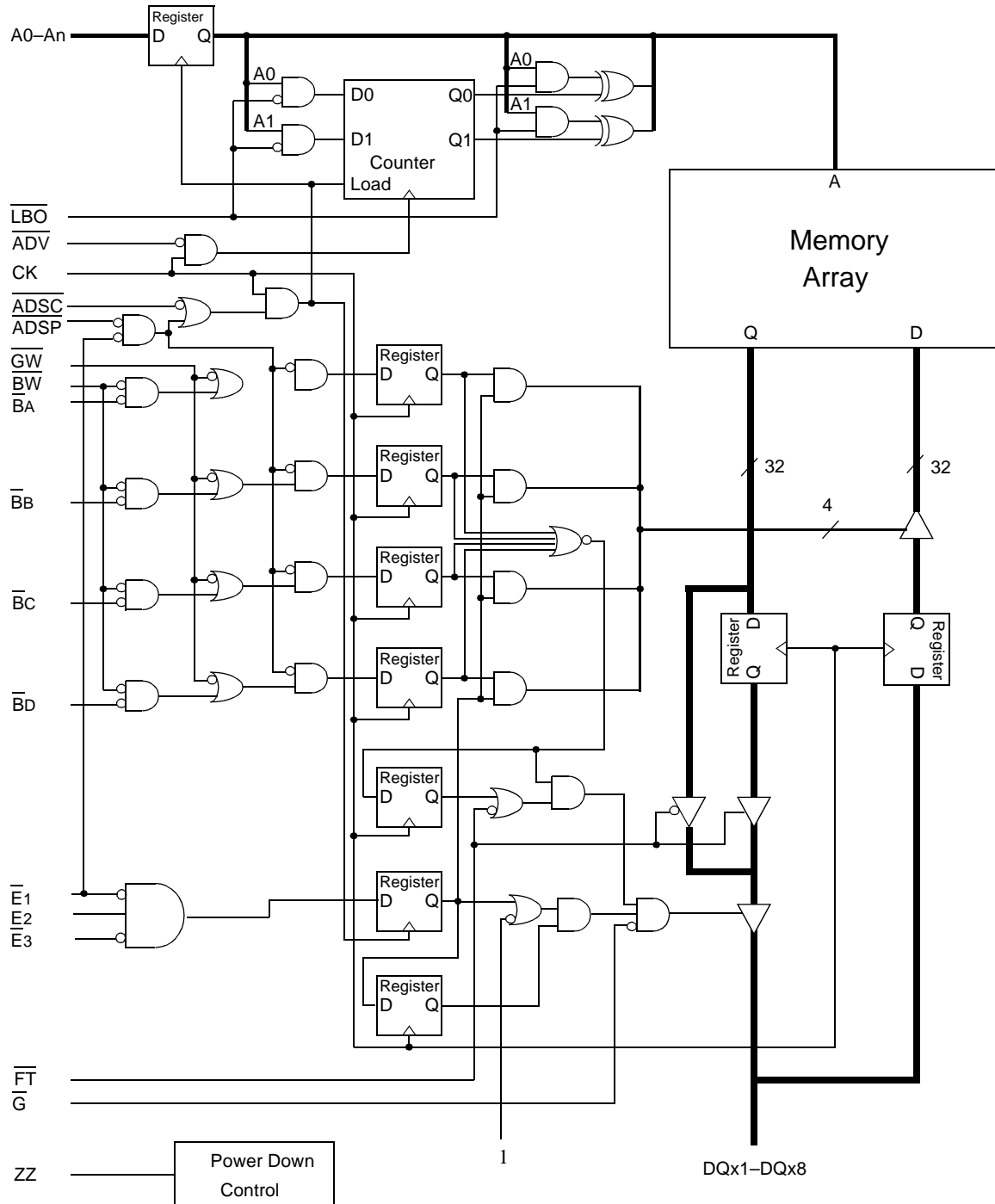

Mode Pin Functions

Mode Name	Pin Name	State	Function
Burst Order Control	$\overline{\text{LBO}}$	L	Linear Burst
		H or NC	Interleaved Burst
Output Register Control	$\overline{\text{FT}}$	L	Flow Through
		H or NC	Pipeline
Power Down Control	ZZ	L or NC	Active
		H	Standby, $I_{DD} = I_{SB}$

Note:

There are pull-up devices on $\overline{\text{LBO}}$ and $\overline{\text{FT}}$ pins and a pull down device on the ZZ pin, so those input pins can be unconnected and the chip will operate in the default states as specified in the above tables.

Burst Counter Sequences

Linear Burst Sequence

	A[1:0]	A[1:0]	A[1:0]	A[1:0]
1st address	00	01	10	11
2nd address	01	10	11	00
3rd address	10	11	00	01
4th address	11	00	01	10

Note: The burst counter wraps to initial state on the 5th clock.

Interleaved Burst Sequence

	A[1:0]	A[1:0]	A[1:0]	A[1:0]
1st address	00	01	10	11
2nd address	01	00	11	10
3rd address	10	11	00	01
4th address	11	10	01	00

Note: The burst counter wraps to initial state on the 5th clock.

Byte Write Truth Table

Function	$\overline{\text{GW}}$	$\overline{\text{BW}}$	$\overline{\text{B}}_A$	$\overline{\text{B}}_B$	$\overline{\text{B}}_C$	$\overline{\text{B}}_D$	Notes
Read	H	H	X	X	X	X	1
Read	H	L	H	H	H	H	1
Write byte A	H	L	L	H	H	H	2, 3
Write byte B	H	L	H	L	H	H	2, 3
Write byte C	H	L	H	H	L	H	2, 3, 4
Write byte D	H	L	H	H	H	L	2, 3, 4
Write all bytes	H	L	L	L	L	L	2, 3, 4
Write all bytes	L	X	X	X	X	X	

Notes:

- All byte outputs are active in read cycles regardless of the state of Byte Write Enable inputs.
- Byte Write Enable inputs $\overline{\text{B}}_A$, $\overline{\text{B}}_B$, $\overline{\text{B}}_C$, and/or $\overline{\text{B}}_D$ may be used in any combination with $\overline{\text{BW}}$ to write single or multiple bytes.
- All byte I/Os remain High-Z during all write operations regardless of the state of Byte Write Enable inputs.

Synchronous Truth Table

Operation	Address Used	State Diagram Key ⁵	\bar{E}_1	E^2	\overline{ADSP}	\overline{ADSC}	\overline{ADV}	W^3	DQ^4
Deselect Cycle, Power Down	None	X	H	X	X	L	X	X	High-Z
Deselect Cycle, Power Down	None	X	L	F	L	X	X	X	High-Z
Deselect Cycle, Power Down	None	X	L	F	H	L	X	X	High-Z
Read Cycle, Begin Burst	External	R	L	T	L	X	X	X	Q
Read Cycle, Begin Burst	External	R	L	T	H	L	X	F	Q
Write Cycle, Begin Burst	External	W	L	T	H	L	X	T	D
<i>Read Cycle, Continue Burst</i>	<i>Next</i>	<i>CR</i>	<i>X</i>	<i>X</i>	<i>H</i>	<i>H</i>	<i>L</i>	<i>F</i>	<i>Q</i>
Read Cycle, Continue Burst	Next	CR	H	X	X	H	L	F	Q
<i>Write Cycle, Continue Burst</i>	<i>Next</i>	<i>CW</i>	<i>X</i>	<i>X</i>	<i>H</i>	<i>H</i>	<i>L</i>	<i>T</i>	<i>D</i>
Write Cycle, Continue Burst	Next	CW	H	X	X	H	L	T	D
Read Cycle, Suspend Burst	Current		X	X	H	H	H	F	Q
Read Cycle, Suspend Burst	Current		H	X	X	H	H	F	Q
Write Cycle, Suspend Burst	Current		X	X	H	H	H	T	D
Write Cycle, Suspend Burst	Current		H	X	X	H	H	T	D

Notes:

1. X = Don't Care, H = High, L = Low.
2. E = T (True) if $E_2 = 1$ and $\bar{E}_3 = 0$; E = F (False) if $E_2 = 0$ or $\bar{E}_3 = 1$.
3. $\bar{W} = T$ (True) and F (False) is defined in the Byte Write Truth Table preceding.
4. \bar{G} is an asynchronous input. \bar{G} can be driven high at any time to disable active output drivers. \bar{G} low can only enable active drivers (shown as "Q" in the Truth Table above).
5. All input combinations shown above are tested and supported. Input combinations shown in gray boxes need not be used to accomplish basic synchronous or synchronous burst operations and may be avoided for simplicity.
6. Tying \overline{ADSP} high and \overline{ADSC} low allows simple non-burst synchronous operations. See **BOLD** items above.
7. Tying \overline{ADSP} high and \overline{ADV} low while using \overline{ADSC} to load new addresses allows simple burst operations. See *ITALIC* items above.

Simplified State Diagram

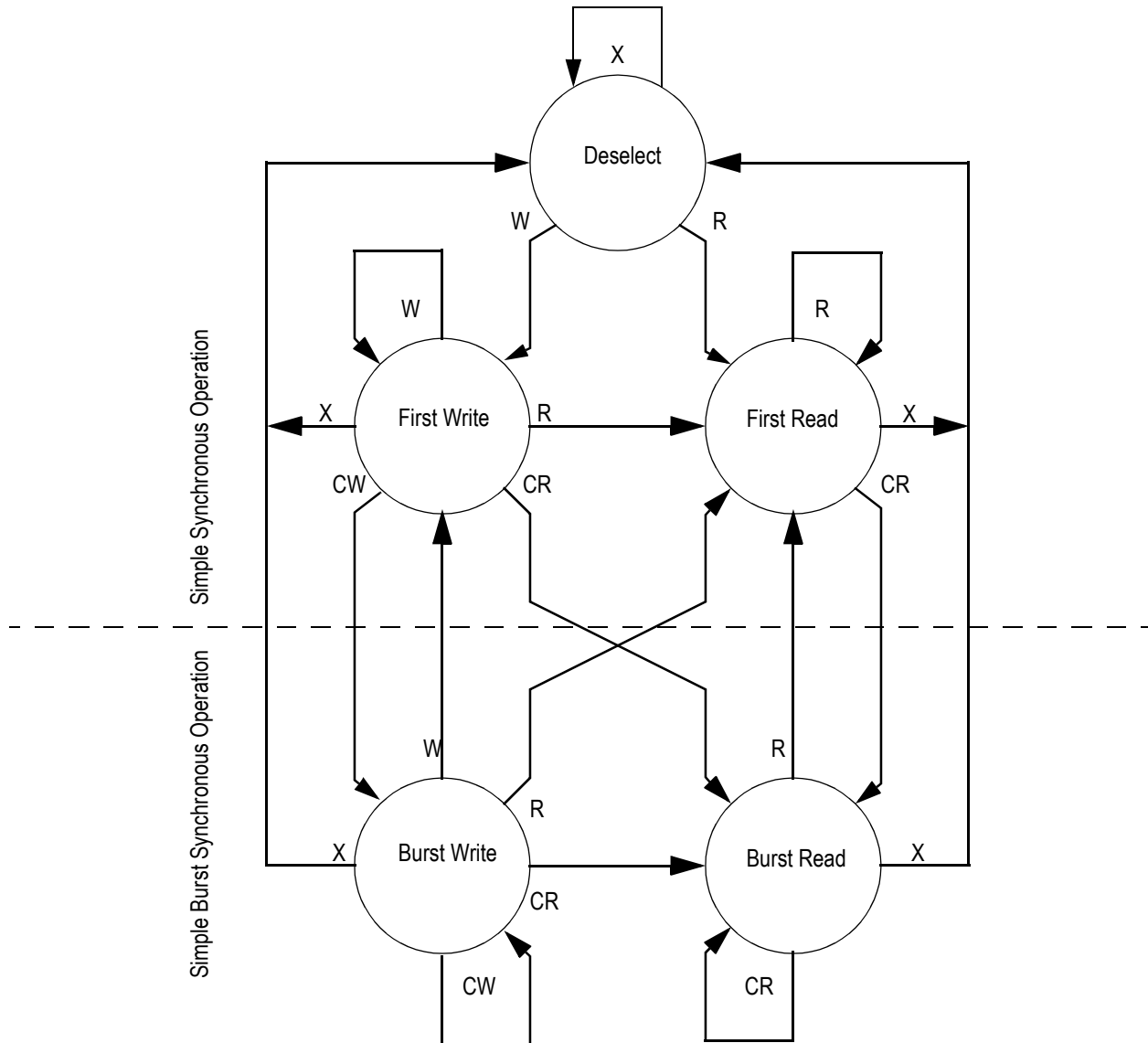

Notes:

1. The diagram shows only supported (tested) synchronous state transitions. The diagram presumes \overline{G} is tied low.
2. The upper portion of the diagram assumes active use of only the Enable ($\overline{E}_1, E_2, \overline{E}_3$) and Write ($\overline{B}_A, \overline{B}_B, \overline{B}_C, \overline{B}_D, \overline{B}_W$, and \overline{G}_W) control inputs, and that \overline{ADSP} is tied high and \overline{ADSC} is tied low.
3. The upper and lower portions of the diagram together assume active use of only the Enable, Write, and \overline{ADSC} control inputs, and assumes \overline{ADSP} is tied high and \overline{ADV} is tied low.

Simplified State Diagram with \overline{G}

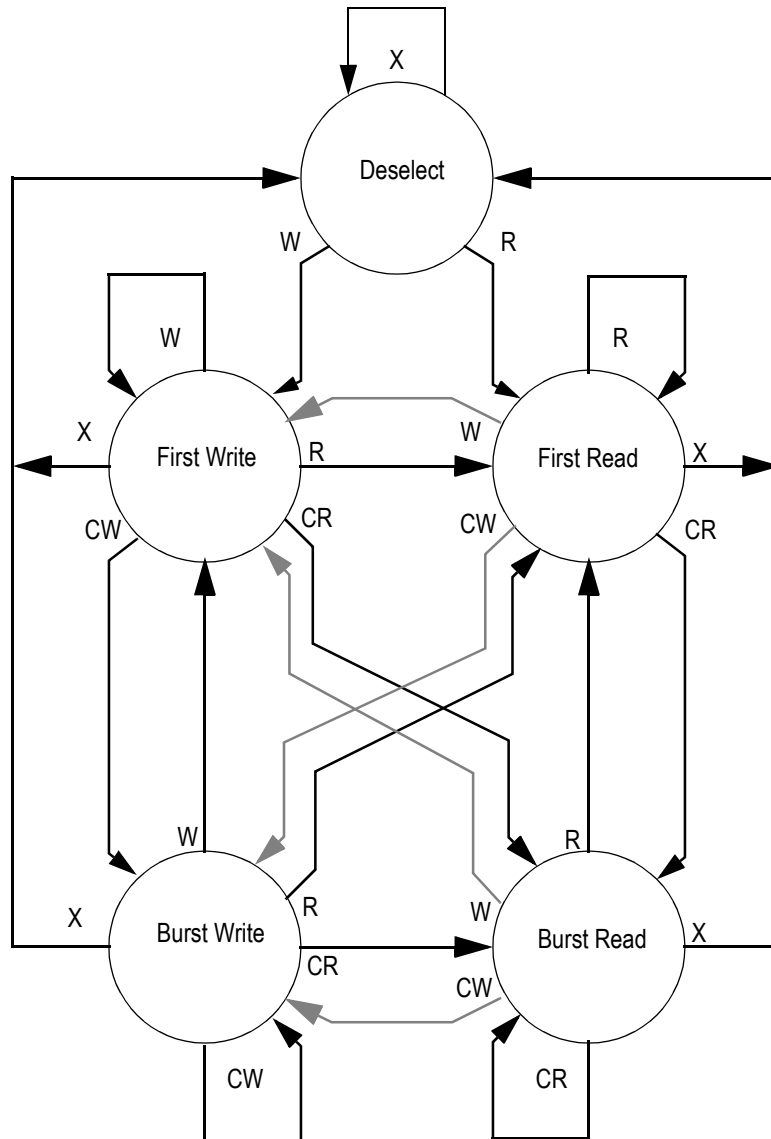

Notes:

1. The diagram shows supported (tested) synchronous state transitions plus supported transitions that depend upon the use of \overline{G} .
2. Use of "Dummy Reads" (Read Cycles with \overline{G} High) may be used to make the transition from read cycles to write cycles without passing through a deselect cycle. Dummy read cycles increment the address counter just like normal read cycles.
3. Transitions shown in gray tone assume \overline{G} has been pulsed high long enough to turn the RAM's drivers off and for incoming data to meet Data Input Set Up Time.

Absolute Maximum Ratings

(All voltages reference to V_{SS})

Symbol	Description	Value	Unit
V_{DD}	Voltage on V_{DD} Pins	-0.5 to 4.6	V
V_{DDQ}	Voltage in V_{DDQ} Pins	-0.5 to V_{DD}	V
V_{CK}	Voltage on Clock Input Pin	-0.5 to 6	V
$V_{I/O}$	Voltage on I/O Pins	-0.5 to $V_{DDQ}+0.5$ (≤ 4.6 V max.)	V
V_{IN}	Voltage on Other Input Pins	-0.5 to $V_{DD}+0.5$ (≤ 4.6 V max.)	V
I_{IN}	Input Current on Any Pin	+/-20	mA
I_{OUT}	Output Current on Any I/O Pin	+/-20	mA
P_D	Package Power Dissipation	1.5	W
T_{STG}	Storage Temperature	-55 to 125	$^{\circ}\text{C}$
T_{BIAS}	Temperature Under Bias	-55 to 125	$^{\circ}\text{C}$

Note:

Permanent damage to the device may occur if the Absolute Maximum Ratings are exceeded. Operation should be restricted to Recommended Operating Conditions. Exposure to conditions exceeding the Absolute Maximum Ratings, for an extended period of time, may affect reliability of this component.

Recommended Operating Conditions

Parameter	Symbol	Min.	Typ.	Max.	Unit	Notes
Supply Voltage	V_{DD}	3.135	3.3	3.6	V	
I/O Supply Voltage	V_{DDQ}	2.375	2.5	V_{DD}	V	1
Input High Voltage	V_{IH}	1.7	—	$V_{DD}+0.3$	V	2
Input Low Voltage	V_{IL}	-0.3	—	0.8	V	2
Ambient Temperature (Commercial Range Versions)	T_A	0	25	70	$^{\circ}\text{C}$	3
Ambient Temperature (Industrial Range Versions)	T_A	-40	25	85	$^{\circ}\text{C}$	3

Notes:

- Unless otherwise noted, all performance specifications quoted are evaluated for worst case at both $2.75\text{ V} \leq V_{DDQ} \leq 2.375\text{ V}$ (i.e., 2.5 V I/O) and $3.6\text{ V} \leq V_{DDQ} \leq 3.135\text{ V}$ (i.e., 3.3 V I/O), and quoted at whichever condition is worst case.
- This device features input buffers compatible with both 3.3 V and 2.5 V I/O drivers.
- Most speed grades and configurations of this device are offered in both Commercial and Industrial Temperature ranges. The part number of Industrial Temperature Range versions end the character "I". Unless otherwise noted, all performance specifications quoted are evaluated for worst case in the temperature range marked on the device.
- Input Under/overshoot voltage must be $-2\text{ V} > V_i < V_{DD}+2\text{ V}$ with a pulse width not to exceed 20% tKC.

Undershoot Measurement and Timing

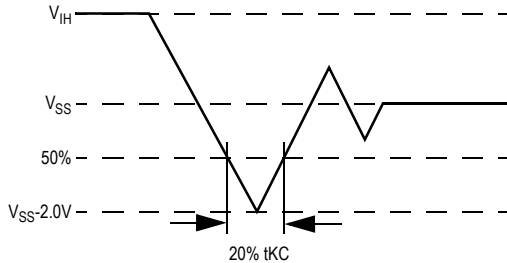

Overshoot Measurement and Timing

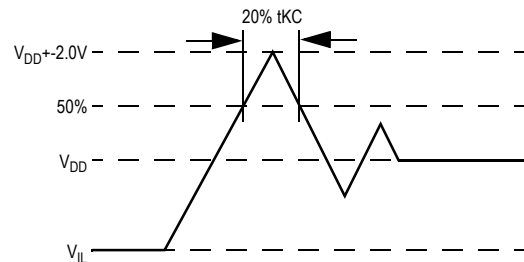

Capacitance

($T_A = 25^\circ\text{C}$, $f = 1\text{ MHz}$, $V_{DD} = 3.3\text{ V}$)

Parameter	Symbol	Test conditions	Typ.	Max.	Unit
Control Input Capacitance	C_I	$V_{DD} = 3.3\text{ V}$	3	4	pF
Input Capacitance	C_{IN}	$V_{IN} = 0\text{ V}$	4	5	pF
Output Capacitance	C_{OUT}	$V_{OUT} = 0\text{ V}$	6	7	pF

Note: This parameter is sample tested.

Package Thermal Characteristics

Rating	Layer Board	Symbol	TQFP Max	QFP Max	Unit	Notes
Junction to Ambient (at 200 lfm)	single	$R_{\theta JA}$	40	TBD	$^\circ\text{C/W}$	1,2,4
Junction to Ambient (at 200 lfm)	four	$R_{\theta JA}$	24	TBD	$^\circ\text{C/W}$	1,2,4
Junction to Case (TOP)		$R_{\theta JC}$	9	TBD	$^\circ\text{C/W}$	3,4

Notes:

- Junction temperature is a function of SRAM power dissipation, package thermal resistance, mounting board temperature, ambient. Temperature air flow, board density, and PCB thermal resistance.
- SCMI G-38-87.
- Average thermal resistance between die and top surface, MIL SPEC-883, Method 1012.1.
- For x18 configuration, consult factory.

AC Test Conditions

Parameter	Conditions
Input high level	2.3V
Input low level	0.2 V
Input slew rate	1 V/ns
Input reference level	1.25 V
Output reference level	1.25 V
Output load	Fig. 1& 2

Notes:

1. Include scope and jig capacitance.
2. Test conditions as specified with output loading as shown in **Fig. 1** unless otherwise noted.
3. Output Load 2 for t_{LZ} , t_{HZ} , t_{OLZ} and t_{OHZ} .
4. Device is deselected as defined by the Truth Table.

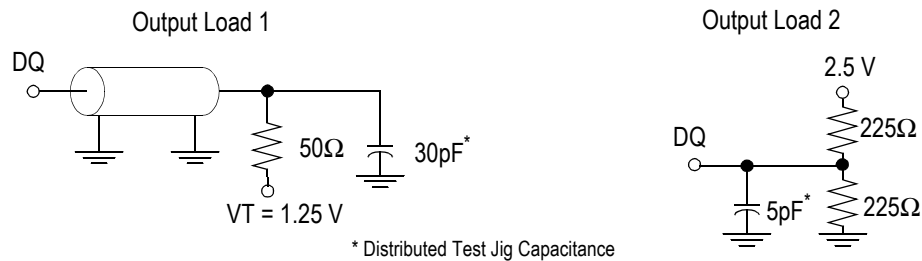

DC Electrical Characteristics

Parameter	Symbol	Test Conditions	Min	Max
Input Leakage Current (except mode pins)	I_{IL}	$V_{IN} = 0 \text{ to } V_{DD}$	-1 μA	1 μA
ZZ Input Current	I_{INZZ}	$V_{DD} \geq V_{IN} \geq V_{IH}$ $0 \text{ V} \leq V_{IN} \leq V_{IH}$	-1 μA -1 μA	1 μA 300 μA
Mode Pin Input Current	I_{INM}	$V_{DD} \geq V_{IN} \geq V_{IL}$ $0 \text{ V} \leq V_{IN} \leq V_{IL}$	-300 μA -1 μA	1 μA 1 μA
Output Leakage Current	I_{OL}	Output Disable, $V_{OUT} = 0 \text{ to } V_{DD}$	-1 μA	1 μA
Output High Voltage	V_{OH}	$I_{OH} = -4 \text{ mA}$, $V_{DDQ} = 2.375 \text{ V}$	1.7 V	
Output High Voltage	V_{OH}	$I_{OH} = -4 \text{ mA}$, $V_{DDQ} = 3.135 \text{ V}$	2.4 V	
Output Low Voltage	V_{OL}	$I_{OL} = 4 \text{ mA}$		0.4 V

Operating Currents

Parameter	Test Conditions	Symbol	-150		-138		-133		-117		-100		-66		Unit
			0 to 70°C	-40 to 85°C	0 to 70°C	-40 to 85°C	0 to 70°C	-40 to 85°C	0 to 70°C	-40 to 85°C	0 to 70°C	-40 to 85°C	0 to 70°C	-40 to 85°C	
Operating Current	Device Selected; All other inputs $\geq V_{IH}$ or $\leq V_{IL}$ Output open	I_{DD} Pipeline	270	275	245	250	240	245	210	215	180	185	150	155	mA
		I_{DD} Flow-Thru	170	175	120	125	120	125	120	125	120	125	95	100	mA
Standby Current	$ZZ \geq V_{DD} - 0.2 V$	I_{SB} Flow-Thru	10	15	10	15	10	15	10	15	10	15	10	15	mA
Deselect Current	Device Deselected; All other inputs $\geq V_{IH}$ or $\leq V_{IL}$	I_{DD} Pipeline	90	95	80	85	80	85	70	75	60	65	50	55	mA
		I_{DD} Flow-Thru	45	50	40	45	40	45	40	45	40	45	40	45	mA

AC Electrical Characteristics

	Parameter	Symbol	-150		-138		-133		-117		-100		-66		Unit
			Min	Max	Min	Max	Min	Max	Min	Max	Min	Max	Min	Max	
Pipeline	Clock Cycle Time	t _{KC}	6.6	—	7.25	—	7.5	—	8.5	—	10	—	12.5	—	ns
	Clock to Output Valid	t _{KQ}	—	3.8	—	4	—	4	—	4.5	—	5	—	6	ns
	Clock to Output Invalid	t _{KQX}	1.5	—	2	—	2	—	2	—	2	—	2	—	ns
	Clock to Output in Low-Z	t _{LZ} ¹	1.5	—	2	—	2	—	2	—	2	—	2	—	ns
Flow Through	Clock Cycle Time	t _{KC}	10.5	—	15	—	15	—	15	—	15	—	20	—	ns
	Clock to Output Valid	t _{KQ}	—	9.0	—	9.7	—	10	—	11	—	12	—	18	ns
	Clock to Output Invalid	t _{KQX}	3	—	3	—	3	—	3	—	3	—	3	—	ns
	Clock to Output in Low-Z	t _{LZ} ¹	3	—	3	—	3	—	3	—	3	—	3	—	ns
	Clock HIGH Time	t _{KH}	1.8	—	1.9	—	1.9	—	2	—	3	—	4	—	ns
	Clock LOW Time	t _{KL}	1.8	—	1.9	—	1.9	—	2	—	3	—	4	—	ns
	Clock to Output in High-Z	t _{HZ} ¹	1.5	3.8	1.5	4	1.5	4	1.5	4	—	5	—	6	ns
	G to Output Valid	t _{OE}	—	3.8	—	4	—	4	—	4	—	5	—	6	ns
	\bar{G} to output in Low-Z	t _{OLZ} ¹	0	—	0	—	0	—	0	—	0	—	0	—	ns
	\bar{G} to output in High-Z	t _{OHZ} ¹	—	4	—	4	—	4	—	4	—	5	—	6	ns
	Setup time	t _S	1.7	—	2	—	2	—	2	—	2	—	2	—	ns
	Hold time	t _H	0.5	—	0.5	—	0.5	—	0.5	—	0.5	—	0.5	—	ns
	ZZ setup time	t _{ZZS} ²	5	—	5	—	5	—	5	—	5	—	5	—	ns
	ZZ hold time	t _{ZZH} ²	1	—	1	—	1	—	1	—	1	—	1	—	ns
	ZZ recovery	t _{ZZR}	20	—	20	—	20	—	20	—	20	—	20	—	ns

Notes:

1. These parameters are sampled and are not 100% tested
2. ZZ is an asynchronous signal. However, in order to be recognized on any given clock cycle, ZZ must meet the specified setup and hold times as specified above.

Write Cycle Timing

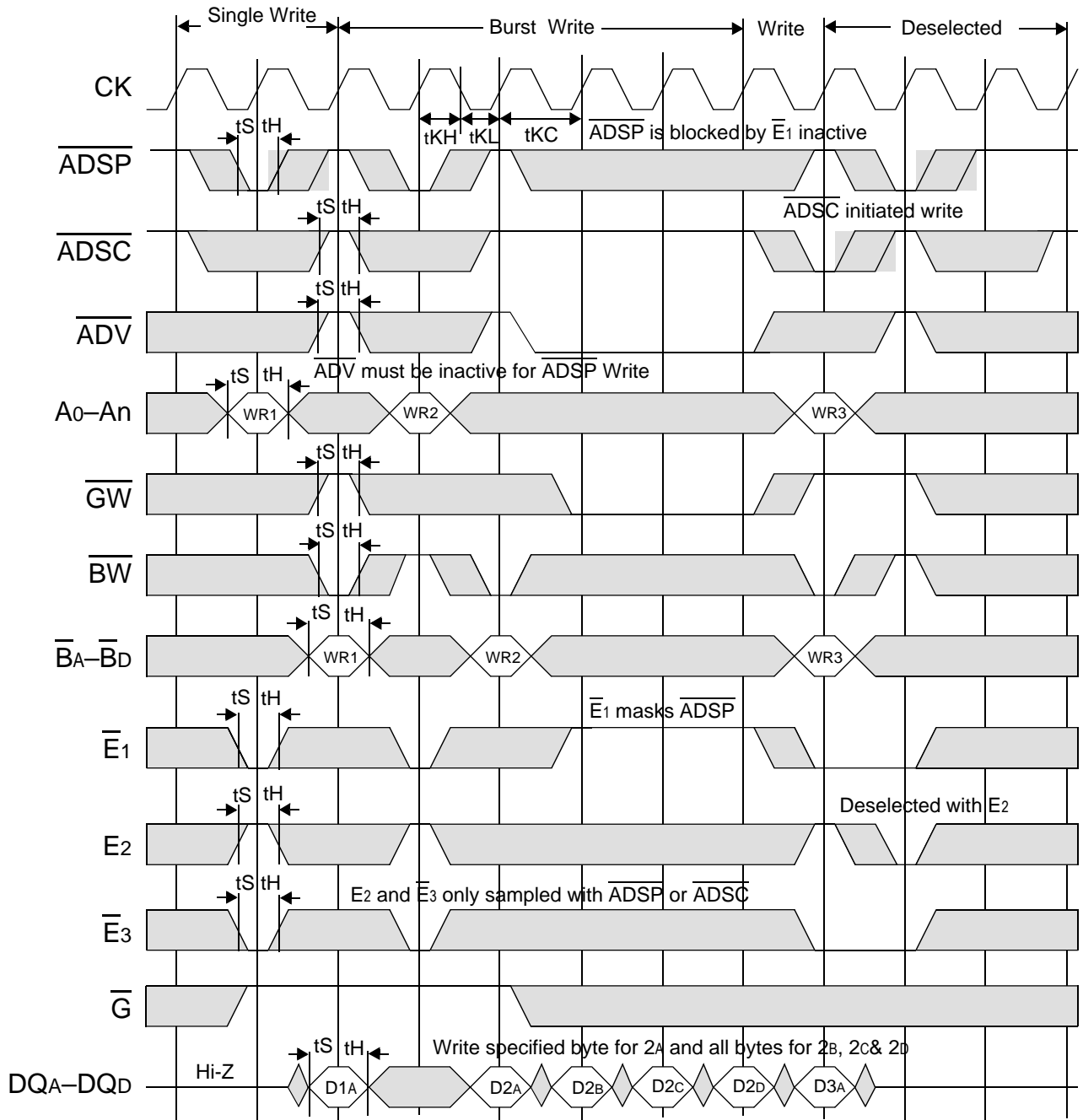

Flow Through Read Cycle Timing

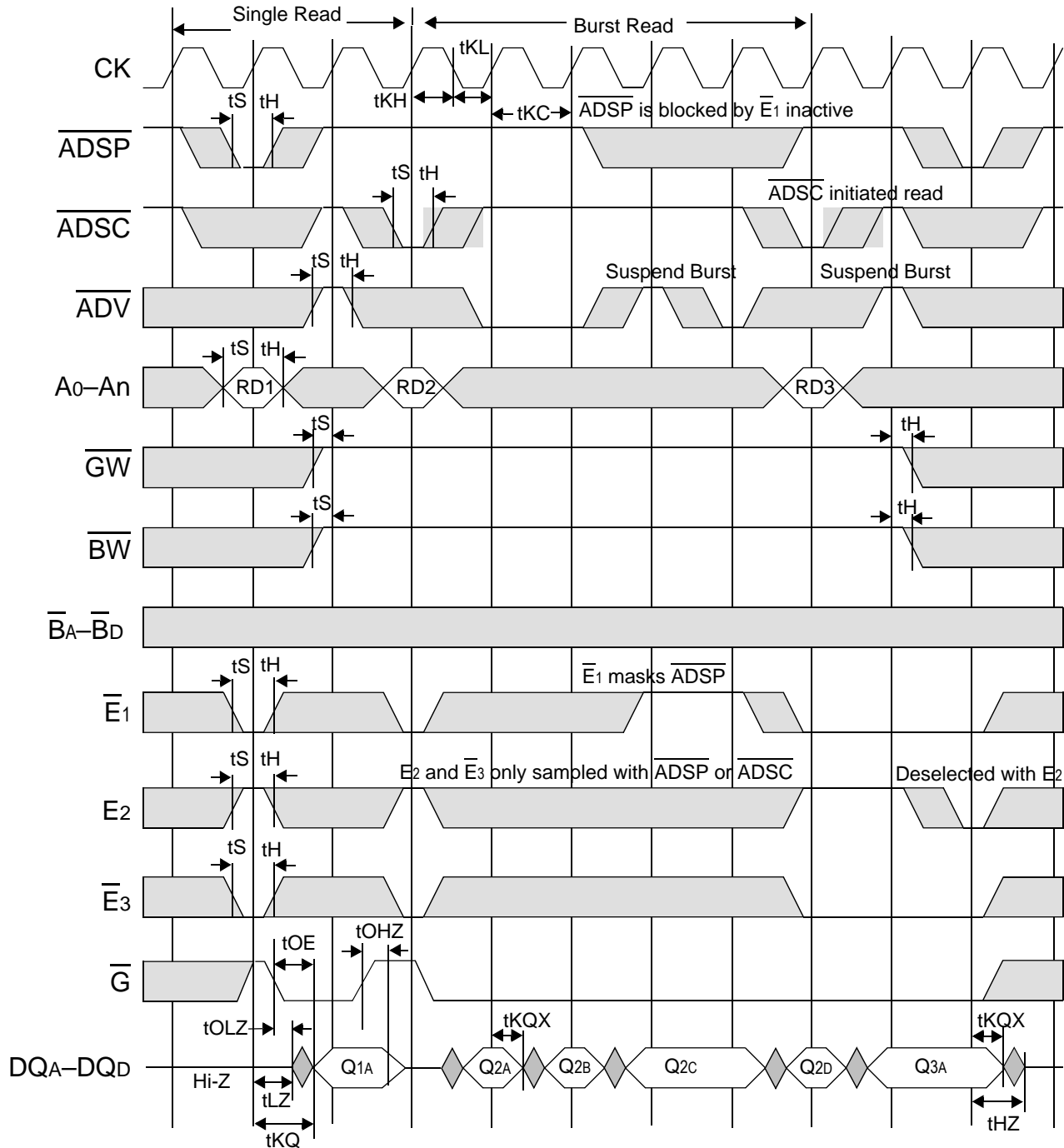

Flow Through Read-Write Cycle Timing

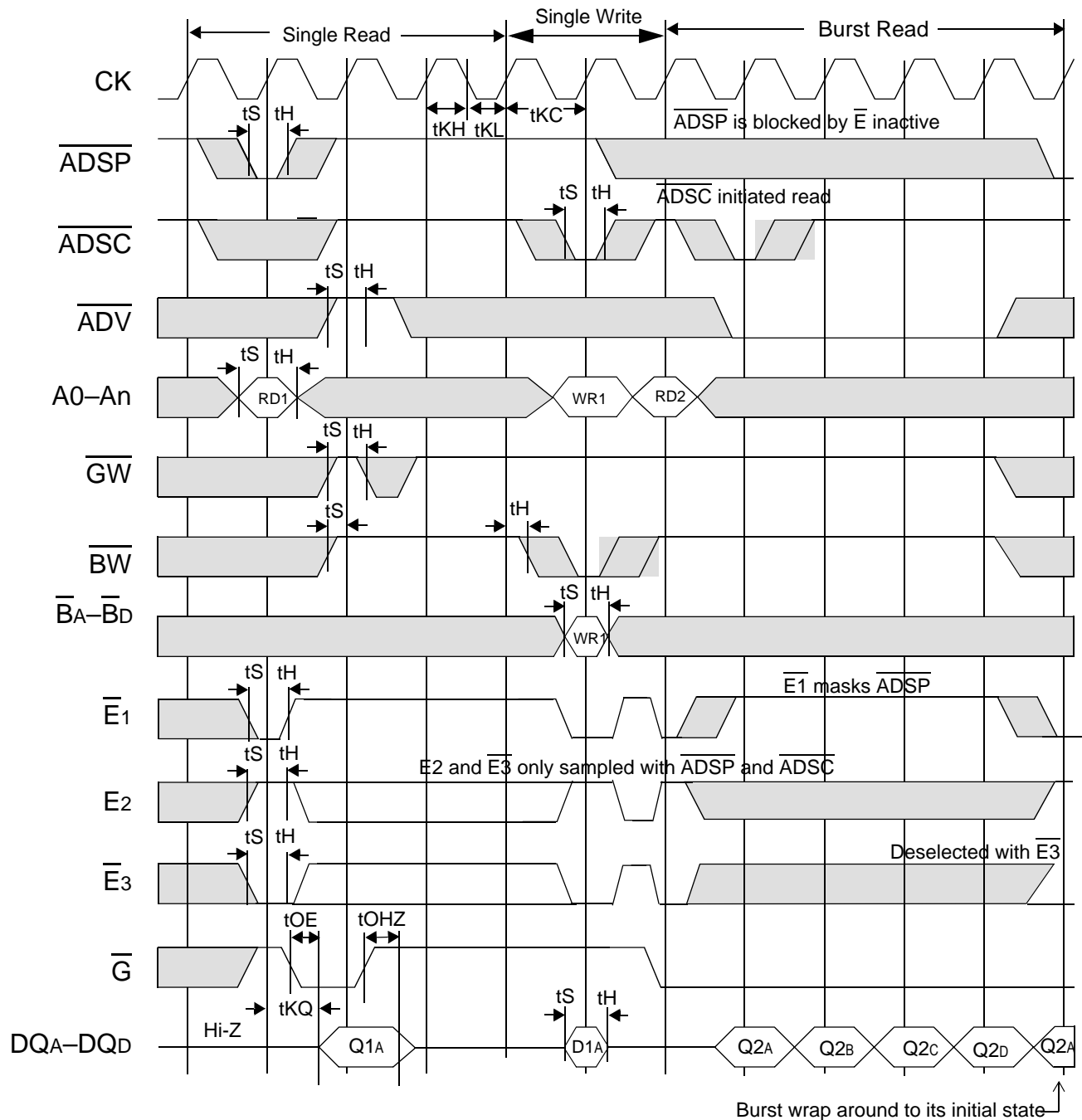

Pipelined SCD Read Cycle Timing

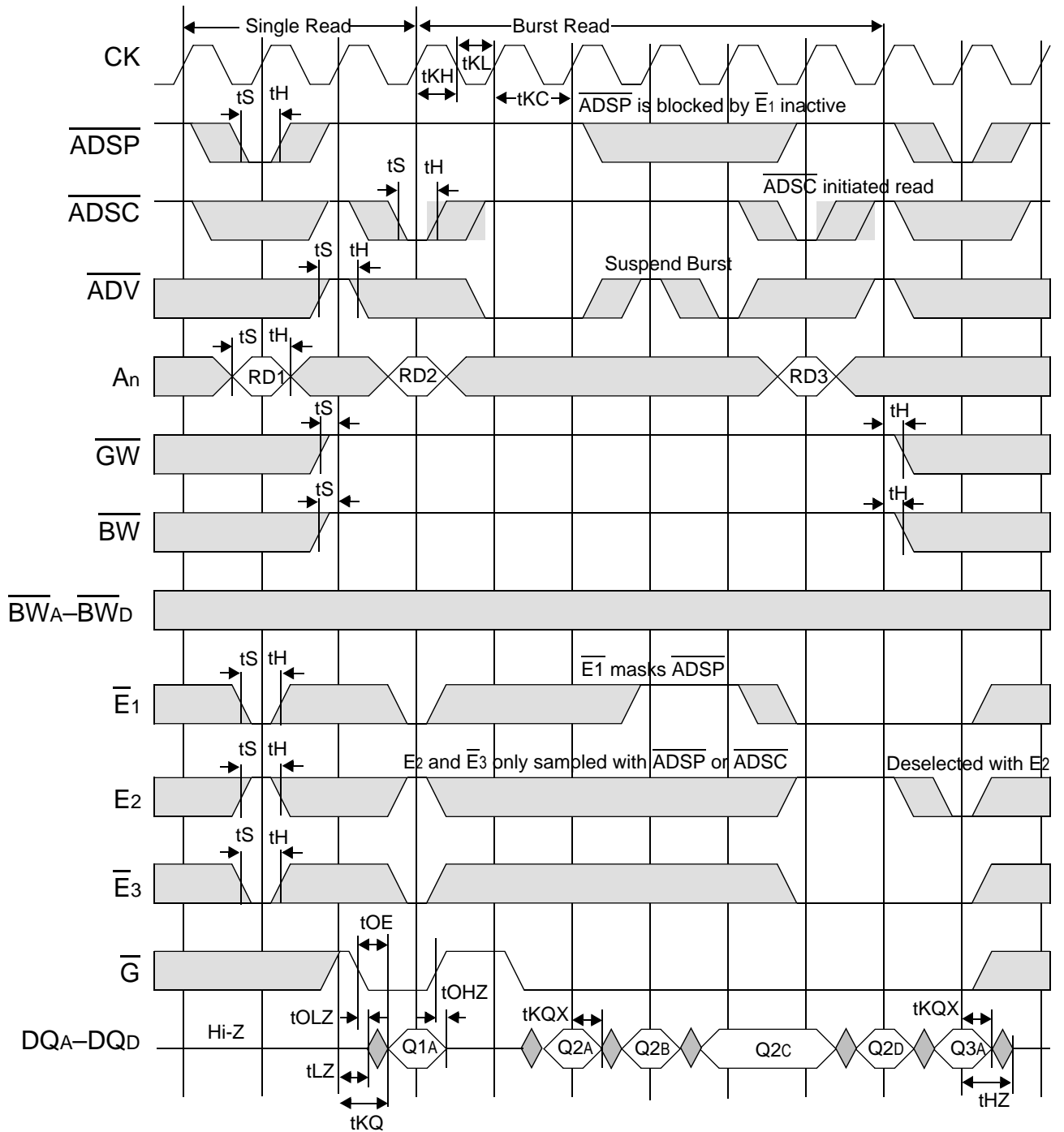

Pipelined SCD Read-Write Cycle Timing

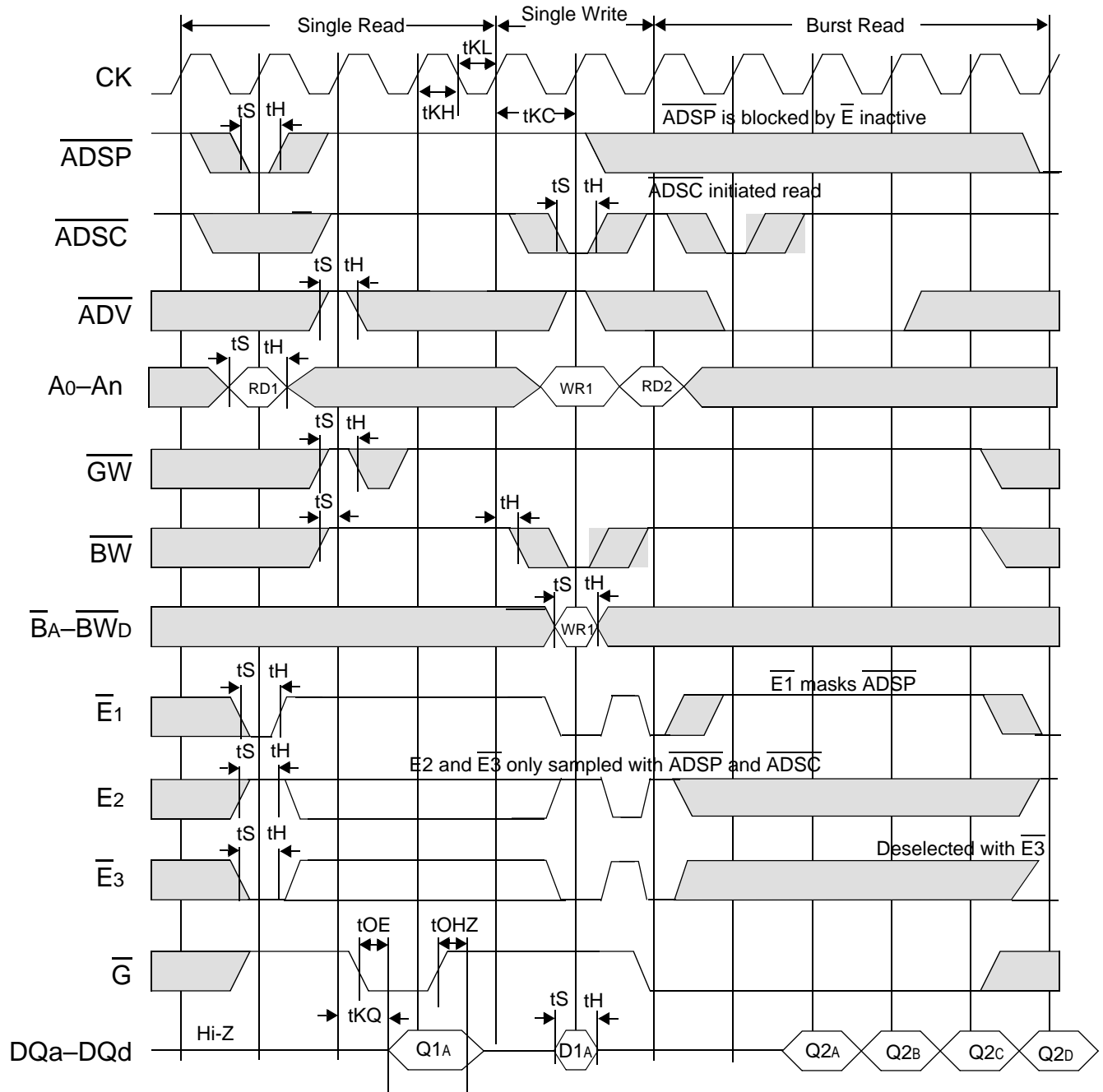

Sleep Mode Timing Diagram

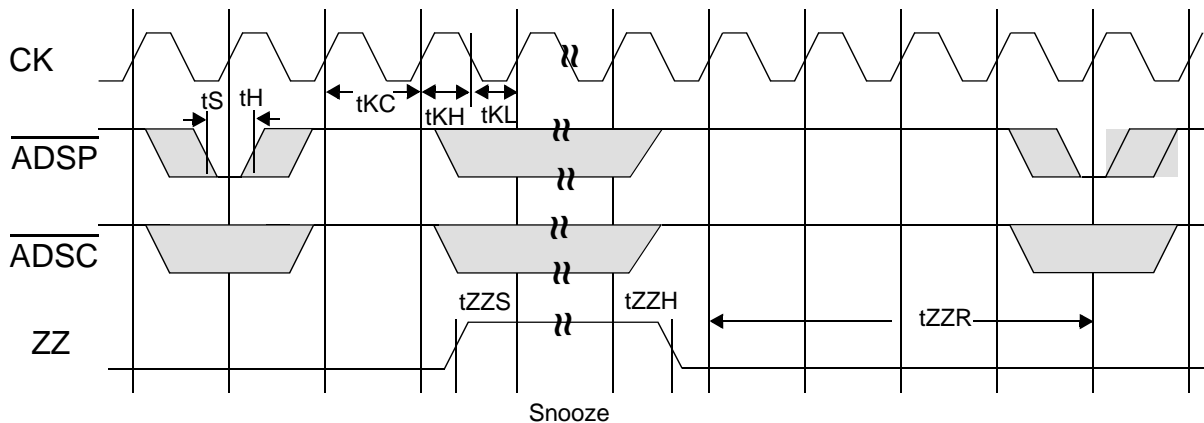

Application Tips

Single and Dual Cycle Deselect

SCD devices force the use of “dummy read cycles” (read cycles that are launched normally, but that are ended with the output drivers inactive) in a fully synchronous environment. Dummy read cycles waste performance, but their use usually assures there will be no bus contention in transitions from reads to writes or between banks of RAMs. DCD SRAMs do not waste bandwidth on dummy cycles, and are logically simpler to manage in a multiple bank application (wait states need not be inserted at bank address boundary crossings), but greater care must be exercised to avoid excessive bus contention.

GS 82032 Output Driver Characteristics

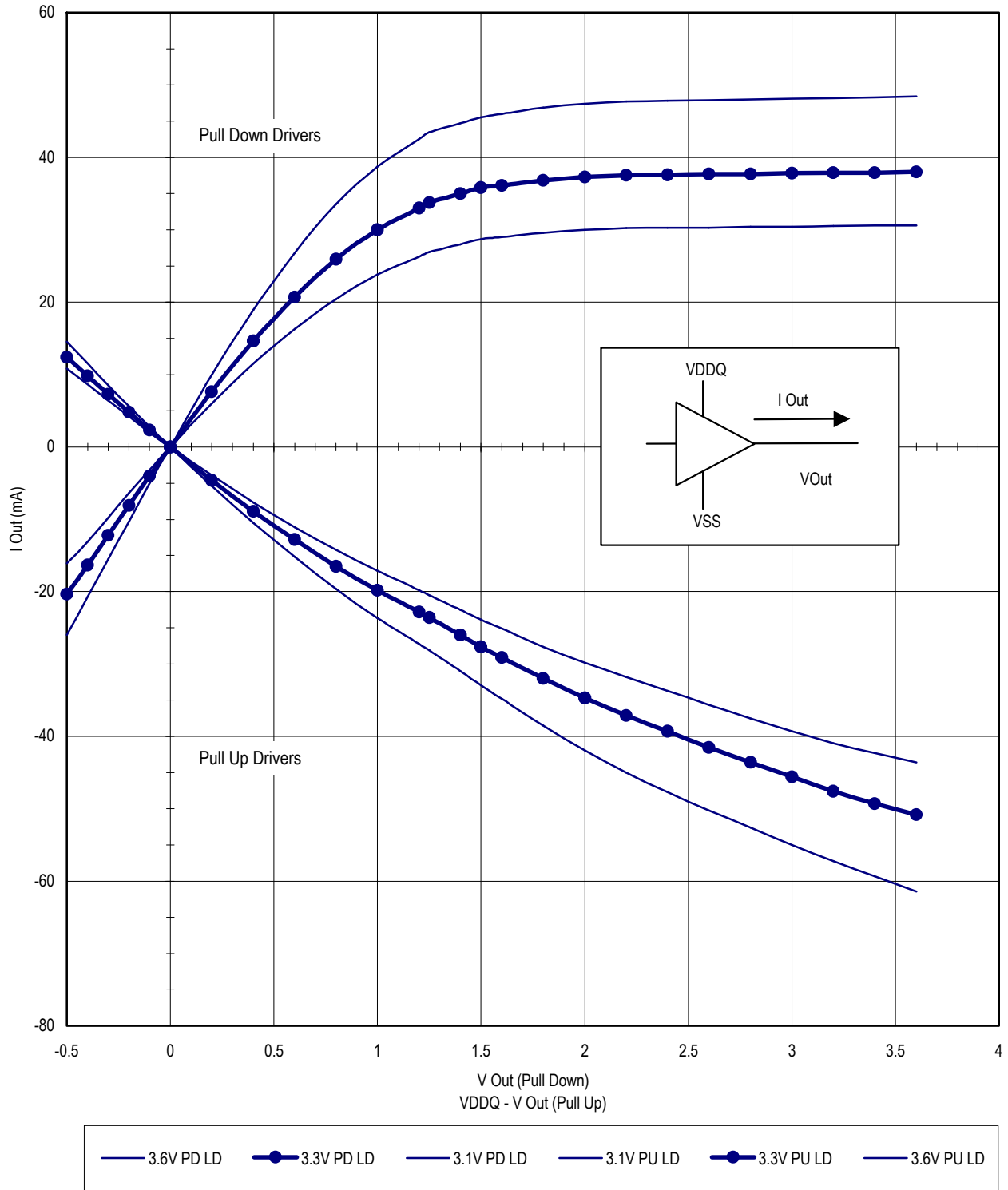

TQFP and QFP Package Drawing

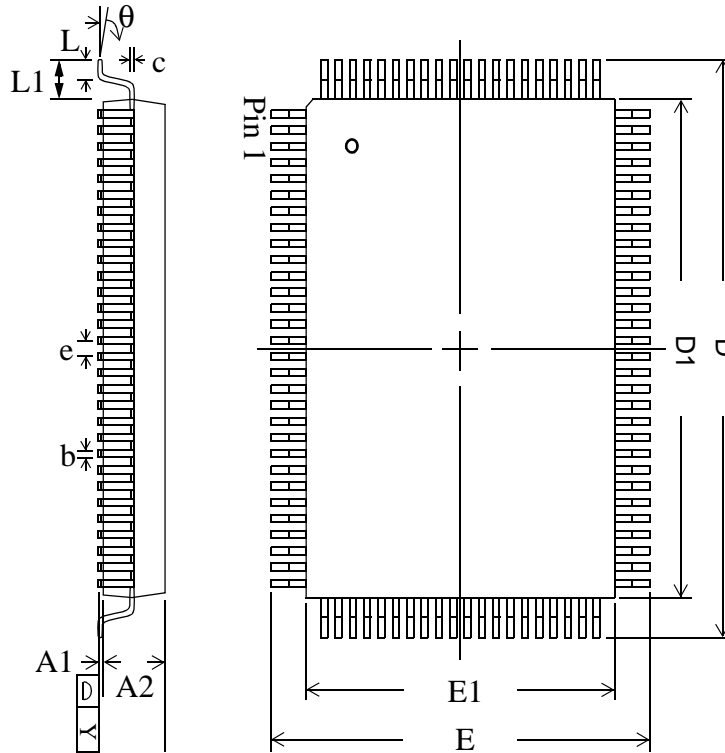

Symbol	Description	TQFP			QFP		
		Min.	Nom.	Max	Min.	Nom.	Max
A1	Standoff	0.05	0.10	0.15	0.25	0.35	0.45
A2	Body Thickness	1.35	1.40	1.45	2.55	2.72	2.90
b	Lead Width	0.20	0.30	0.40	0.20	0.30	0.40
c	Lead Thickness	0.09	—	0.20	0.10	0.15	0.20
D	Terminal Dimension	21.9	22.0	22.1	22.95	23.2	23.45
D1	Package Body	19.9	20.0	20.1	19.9	20.0	20.1
E	Terminal Dimension	15.9	16.0	16.1	17.0	17.2	17.4
E1	Package Body	13.9	14.0	14.1	13.9	14.0	14.1
e	Lead Pitch	—	0.65	—	—	0.65	—
L	Foot Length	0.45	0.60	0.75	.60	0.80	1.00
L1	Lead Length	—	1.00		—	1.60	—
Y	Coplanarity	—	—	0.10	—	—	0.10
θ	Lead Angle	0°	—	7°	0°	—	7°

Notes:

1. All dimensions are in millimeters (mm).
2. Package width and length do not include mold protrusion

Ordering Information

Org	Part Number ¹	Type	Package	Speed ² (MHz/ns)	T _A 3	Status
64K x 32	GS82032T-150	Pipeline/Flow Through	TQFP	150/9	C	
64K x 32	GS820322T-138	Pipeline/Flow Through	TQFP	138/9.7	C	
64K x 32	GS82032T-133	Pipeline/Flow Through	TQFP	133/10	C	
64K x 32	GS82032T-4	Pipeline/Flow Through	TQFP	133/10	C	
64K x 32	GS82032T-5	Pipeline/Flow Through	TQFP	100/12	C	
64K x 32	GS82032T-6	Pipeline/Flow Through	TQFP	66/18	C	
64K x 32	GS82032T-150I	Pipeline/Flow Through	TQFP	150/9	I	Not Available
64K x 32	GS82032T-138I	Pipeline/Flow Through	TQFP	138/9.7	I	
64K x 32	GS82032T-133I	Pipeline/Flow Through	TQFP	133/10	I	
64K x 32	GS82032T-4I	Pipeline/Flow Through	TQFP	133/10	I	
64K x 32	GS82032T-5I	Pipeline/Flow Through	TQFP	100/12	I	
64K x 32	GS82032T-6I	Pipeline/Flow Through	TQFP	66/18	I	
64K x 32	GS82032Q-150	Pipeline/Flow Through	QFP	150/9	C	
64K x 32	GS82032Q-138	Pipeline/Flow Through	QFP	138/9.7	C	
64K x 32	GS82032Q-133	Pipeline/Flow Through	QFP	133/10	C	
64K x 32	GS82032Q-4	Pipeline/Flow Through	QFP	133/10	C	
64K x 32	GS82032Q-5	Pipeline/Flow Through	QFP	100/12	C	
64K x 32	GS82032Q-6	Pipeline/Flow Through	QFP	66/18	C	
64K x 32	GS82032Q-150I	Pipeline/Flow Through	QFP	150/9	I	Not Available
64K x 32	GS82032Q-138I	Pipeline/Flow Through	QFP	138/9.7	I	
64K x 32	GS82032Q-133I	Pipeline/Flow Through	QFP	133/10	I	
64K x 32	GS82032Q-4I	Pipeline/Flow Through	QFP	133/10	I	
64K x 32	GS82032Q-5I	Pipeline/Flow Through	QFP	100/12	I	
64K x 32	GS82032Q-6I	Pipeline/Flow Through	QFP	66/18	I	

Notes:

- Customers requiring delivery in Tape and Reel should add the character "T" to the end of the part number. Example: GS82032T-100IT.
- The speed column indicates the cycle frequency (MHz) of the device in Pipeline mode and the latency (ns) in Flow Through mode. Each device is Pipeline/Flow Through mode-selectable by the user.
- T_A = C = Commercial Temperature Range. T_A = I = Industrial Temperature Range.
- GSI offers other versions this type of device in many different configurations and with a variety of different features, only some of which are covered in this data sheet. See the GSI Technology web site(www.gsitechnology.com)for a complete listing of current offerings.

Revision History

DS/DateRev. Code: Old; New	Types of Changes Format or Content	Revisions
GS GS82032 Rev 1.00 9/ 1999A	Format	<ul style="list-style-type: none"> • This was the first release of 2 Meg Burst Datasheets in the new format. They included information for the Fine Pitch BGA package.
GS GS82032 Rev 1.00 9/ 1999A; 1.01 11/1999B	Content	<ul style="list-style-type: none"> • Took out the Fine Pitch BGA information.
GS GS82032 Rev 1.01 11/ 1999B; 1.02 1/2000C	Content	<ul style="list-style-type: none"> • Ordering information. Changed 128K x 32 to 64K x 32; Typo • Ordering information. Changed "0" to go before "H" or "E" in part number. • Ordering information. Changed - 117 to -4, -100 to -5. and -66 to -6.
GS820321.02 1/ 2000C;820321.03 2/2000D	Format/Content	<ul style="list-style-type: none"> • New GSI Logo • Switched TKQ with TCycle in Flow Through part of table on page 1.
820321.03 2/2000D; 82032_r1_04	Format/Content	<ul style="list-style-type: none"> • Updated format to comply with Technical Publication Standards • Changed all -4 references in ordering information table on page 22 from 117/11 to 133/10.