

GENNUM

GS9090B GenLINX® III 270Mb/s Deserializer for SDI

GS9090B Data Sheet

Key Features

- SMPTE 259M-C compliant descrambling and NRZI to NRZ decoding (with bypass)
- DVB-ASI sync word detection and 8b/10b decoding
- Integrated line-based FIFO for data alignment/delay, clock phase interchange, DVB-ASI data packet extraction and clock rate interchange, and ancillary data packet extraction
- Integrated VCO and reclocker
- Automatic or manual selection between SMPTE video and DVB-ASI data
- User selectable additional processing features including:
 - TRS, ANC data checksum, and EDH CRC error detection and correction
 - programmable ANC data detection
 - illegal code remapping
- Internal flywheel for noise immune H, V, F extraction
- Automatic standards detection and indication
- Enhanced Gennum Serial Peripheral Interface (GSPI)
- JTAG test interface
- Polarity insensitive for DVB-ASI and SMPTE signals
- +1.8V core power supply with optional +1.8V or +3.3V I/O power supply
- Small footprint (8mm x 8mm)
- Low power operation (typically 145mW)
- Pb-free

Applications

- SMPTE 259M-C Serial Digital Interfaces
- DVB-ASI Serial Digital Interfaces

Description

The GS9090B is a 270Mb/s reclocking deserializer with an internal FIFO. It provides a complete receive solution for SD-SDI and DVB-ASI applications.

In addition to reclocking and deserializing the input data stream, the GS9090B performs NRZI-to-NRZ decoding, descrambling as per SMPTE 259M-C, and word alignment when operating in SMPTE mode. When operating in DVB-ASI mode, the device will word align the data to K28.5 sync characters and 8b/10b decode the received stream.

The internal reclocker features a very wide input jitter tolerance, and is fully compatible with both SMPTE and DVB-ASI input streams.

The GS9090B includes a range of data processing functions such as EDH support (error detection and handling), and automatic standards detection. The device can also detect and extract SMPTE 352M payload identifier packets and independently identify the received video standard. This information is read from internal registers via the host interface port.

The GS9090B also incorporates a video line-based FIFO. This FIFO may be used in four user-selectable modes to carry out tasks such as data alignment / delay, clock phase interchange, MPEG packet extraction and clock rate interchange, and ancillary data packet extraction.

Parallel data outputs are provided in 10-bit multiplexed format, with the associated parallel clock output signal operating at 27MHz.

The device may also be used in a low-latency data pass through mode where only descrambling and word alignment will be performed in SMPTE mode.

Functional Block Diagram

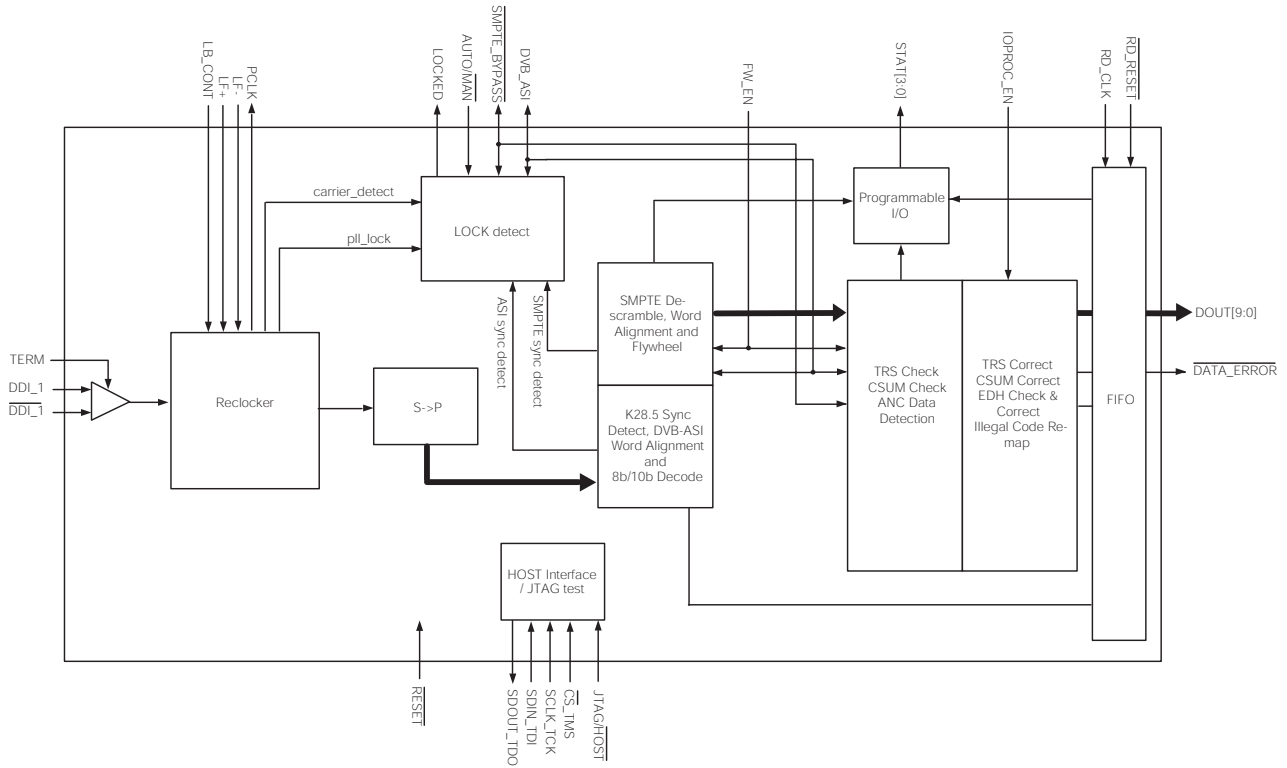

GS9090B Functional Block Diagram

Contents

Key Features.....	1
Applications.....	1
Description.....	1
Functional Block Diagram.....	2
1. Pin Out.....	5
1.1 Pin Assignment.....	5
2. Electrical Characteristics.....	12
2.1 Absolute Maximum Ratings.....	12
2.2 DC Characteristics.....	12
2.3 AC Electrical Characteristics.....	13
2.4 Solder Reflow Profiles.....	15
2.5 Host Interface Map.....	16
2.5.1 Host Interface Map (R/W registers).....	18
2.5.2 Host Interface Map (Read only registers).....	20
3. Detailed Description.....	22
3.1 Functional Overview.....	22
3.2 Serial Digital Input.....	22
3.3 Clock and Data Recovery.....	23
3.3.1 Internal VCO and Phase Detector.....	23
3.4 Serial-To-Parallel Conversion.....	23
3.5 Modes Of Operation.....	23
3.5.1 Lock Detect.....	24
3.5.2 Auto Mode.....	26
3.5.3 Manual Mode.....	26
3.6 SMPTE Functionality.....	27
3.6.1 SMPTE Descrambling and Word Alignment.....	27
3.6.2 Internal Flywheel.....	27
3.6.3 Switch Line Lock Handling.....	28
3.6.4 HVF Timing Signal Generation.....	29
3.7 DVB-ASI Functionality.....	30
3.7.1 DVB-ASI 8b/10b Decoding.....	31
3.7.2 Status Signal Outputs.....	31
3.8 Data-Through Functionality.....	31
3.9 Additional Processing Features.....	32
3.9.1 FIFO Load Pulse.....	32
3.9.2 Ancillary Data Detection and Indication.....	33
3.9.3 EDH Packet Detection.....	34
3.9.4 EDH Flag Detection.....	35
3.9.5 SMPTE 352M Payload Identifier.....	37
3.9.6 Automatic Video Standard and Data Format Detection.....	38

3.9.7 Error Detection and Indication	39
3.9.8 Additional Processing Functions.....	44
3.10 Internal FIFO Operation	47
3.10.1 Video Mode.....	47
3.10.2 DVB-ASI Mode	48
3.10.3 Ancillary Data Extraction Mode.....	52
3.10.4 Bypass Mode	55
3.11 Parallel Data Outputs.....	55
3.11.1 Parallel Data Bus Output Buffers.....	56
3.11.2 Parallel Output in SMPTE Mode.....	56
3.11.3 Parallel Output in DVB-ASI Mode.....	56
3.11.4 Parallel Output in Data-Through Mode	56
3.12 Programmable Multi-Function Outputs	56
3.13 GS9090B Low-latency Mode	58
3.14 GSPI Host Interface	59
3.14.1 Command Word Description.....	60
3.14.2 Data Read and Write Timing	60
3.14.3 Configuration and Status Registers	62
3.15 JTAG Operation	62
3.16 Device Power Up	63
4. References & Relevant Standards	65
5. Application Information.....	66
5.1 Typical Application Circuit (Part A)	66
5.2 Typical Application Circuit (Part B)	67
6. Package & Ordering Information.....	68
6.1 Package Dimensions	68
6.2 Recommended PCB Footprint.....	69
6.3 Packaging Data.....	69
6.4 Marking Diagram.....	70
6.5 Ordering Information	70
7. Revision History	71

1. Pin Out

1.1 Pin Assignment

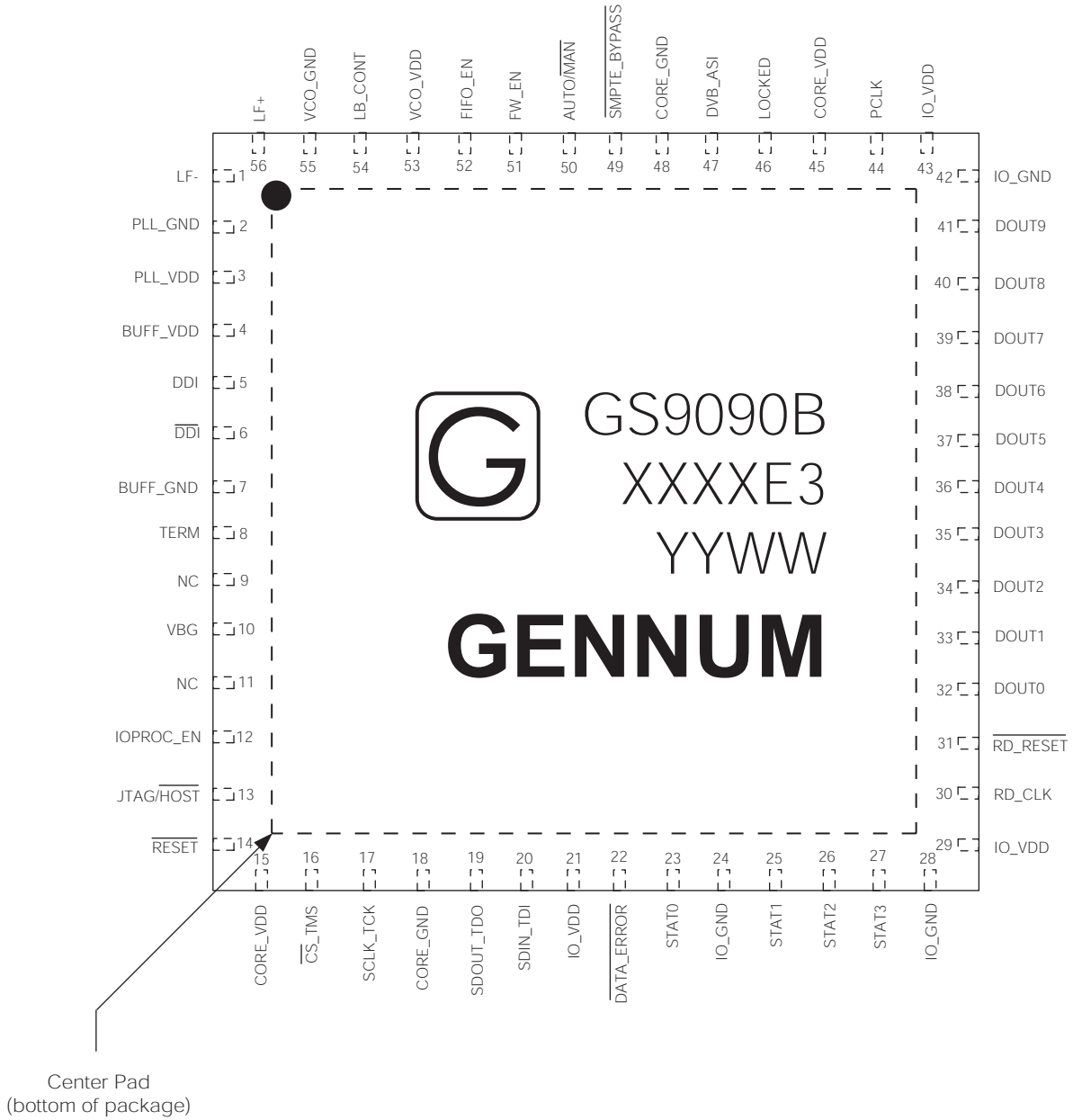

Figure 1-1: Pin Assignment

Table 1-1: Pin List and Description

Pin Number	Name	Timing	Type	Description
1	LF-	Analog	Input	Loop filter component connection. Connect to pin 56 (LF+) as shown in Typical Application Circuit (Part B) on page 67 .
2	PLL_GND	Analog	Input Power	Ground connection for phase-locked loop. Connect to GND.
3	PLL_VDD	Analog	Input Power	Power supply connection for phase-locked loop. Connect to +1.8V DC.
4	BUFF_VDD	Analog	Input Power	Power supply connection for digital input buffers. When DDI/DDI are AC coupled, this pin should be left unconnected. When DDI/DDI are DC coupled, this pin should be connected to +3.3V as shown in Typical Application Circuit (Part B) on page 67 . See Serial Digital Input on page 22 for more details.
5, 6	DDI, $\overline{\text{DDI}}$	Analog	Input	Serial digital differential input pair.
7	BUFF_GND	Analog	Input Power	Ground connection for serial digital input buffer. Connect to GND.
8	TERM	Analog	Input	Termination for serial digital input. AC couple to BUFF_GND
9, 11	NC	–	–	No connect.
10	VBG	Analog	Input	Bandgap filter capacitor. Connect to GND as shown in Typical Application Circuit (Part B) on page 67 .
12	IOPROC_EN	Non Synchronous	Input	CONTROL SIGNAL INPUT Signal Levels are LVCMOS / LVTTTL compatible. Used to enable or disable the I/O processing features. When set HIGH, the following I/O processing features of the device are enabled: <ul style="list-style-type: none"> • Illegal Code Remapping • EDH CRC Error Correction • Ancillary Data Checksum Error Correction • TRS Error Correction • EDH Flag Detection To enable a subset of these features, keep the IOPROC_EN pin HIGH and disable the individual feature(s) in the IOPROC_DISABLE register accessible via the host interface. When set LOW, the device will enter low-latency mode. NOTE: When the internal FIFO is configured for Video mode or Ancillary Data Extraction mode, the IOPROC_EN pin must be set HIGH (see Internal FIFO Operation on page 47).
13	JTAG/ $\overline{\text{HOST}}$	Non Synchronous	Input	CONTROL SIGNAL INPUT Signal levels are LVCMOS / LVTTTL compatible. Used to select JTAG Test Mode or Host Interface Mode. When set HIGH, $\overline{\text{CS_TMS}}$, SCLK_TCK, SDOUT_TDO, and SDIN_TDI are configured for JTAG boundary scan testing. When set LOW, $\overline{\text{CS_TMS}}$, SCLK_TCK, SDOUT_TDO, and SDIN_TDI are configured as GSPI pins for normal host interface operation.

Table 1-1: Pin List and Description (Continued)

14	$\overline{\text{RESET}}$	Non Synchronous	Input	<p>CONTROL SIGNAL INPUT Signal levels are LVCMOS / LVTTTL compatible.</p> <p>Used to reset the internal operating conditions to default setting or to reset the JTAG test sequence.</p> <p>Host Mode (JTAG/$\overline{\text{HOST}}$ = LOW): When asserted LOW, all functional blocks will be set to default conditions and all output signals become high impedance with the exception of the STAT pins and the $\overline{\text{DATA_ERROR}}$ pin which will maintain the last state they were in for the duration that $\overline{\text{RESET}}$ is asserted.</p> <p>JTAG Test Mode (JTAG/$\overline{\text{HOST}}$ = HIGH): When asserted LOW, all functional blocks will be set to default and the JTAG test sequence will be held in reset.</p> <p>When set HIGH, normal operation of the JTAG test sequence resumes.</p> <p>NOTE: See Device Power Up on page 63 for power on reset requirements.</p>
15, 45	CORE_VDD	Non Synchronous	Input Power	<p>Power supply for digital logic blocks. Connect to +1.8V DC.</p> <p>NOTE: For power sequencing requirements please see Device Power Up on page 63.</p>
16	$\overline{\text{CS_TMS}}$	Synchronous with SCLK_TCK	Input	<p>CONTROL SIGNAL INPUT Signal levels are LVCMOS / LVTTTL compatible.</p> <p>Chip Select / Test Mode Select</p> <p>Host Mode (JTAG/$\overline{\text{HOST}}$ = LOW): $\overline{\text{CS_TMS}}$ operates as the host interface chip select, $\overline{\text{CS}}$, and is active LOW.</p> <p>JTAG Test Mode (JTAG/$\overline{\text{HOST}}$ = HIGH): $\overline{\text{CS_TMS}}$ operates as the JTAG test mode select, TMS, and is active HIGH.</p>
17	SCLK_TCK	Non Synchronous	Input	<p>CONTROL SIGNAL INPUT Signal levels are LVCMOS / LVTTTL compatible.</p> <p>Serial Data Clock / Test Clock. All JTAG / Host Interface address and data are shifted into/out of the device synchronously with this clock.</p> <p>Host Mode (JTAG/$\overline{\text{HOST}}$ = LOW): SCLK_TCK operates as the host interface serial data clock, SCLK.</p> <p>JTAG Test Mode (JTAG/$\overline{\text{HOST}}$ = HIGH): SCLK_TCK operates as the JTAG test clock, TCK.</p>
18, 48	CORE_GND	Non Synchronous	Input Power	<p>Ground connection for digital logic blocks. Connect to GND.</p>
19	SDOUT_TDO	Synchronous with SCLK_TCK	Output	<p>CONTROL SIGNAL INPUT Signal levels are LVCMOS / LVTTTL compatible.</p> <p>Serial Data Output / Test Data Output</p> <p>Host Mode (JTAG/$\overline{\text{HOST}}$ = LOW): SDOUT_TDO operates as the host interface serial output, SDOUT, used to read status and configuration information from the internal registers of the device.</p> <p>JTAG Test Mode (JTAG/$\overline{\text{HOST}}$ = HIGH): SDOUT_TDO operates as the JTAG test data output, TDO.</p>

Table 1-1: Pin List and Description (Continued)

20	SDIN_TDI	Synchronous with SCLK_TCK	Input	<p>CONTROL SIGNAL INPUT Signal levels are LVCMOS / LVTTTL compatible.</p> <p>Serial Data Input / Test Data Input</p> <p>Host Mode (JTAG/HOST = LOW): SDIN_TDI operates as the host interface serial input, SDIN, used to write address and configuration information to the internal registers of the device.</p> <p>JTAG Test Mode (JTAG/HOST = HIGH): SDIN_TDI operates as the JTAG test data input, TDI.</p>
21, 29, 43	IO_VDD	Non Synchronous	Input Power	<p>Power supply for digital I/O.</p> <p>For a 3.3V tolerant I/O, connect pins to either +1.8V DC or +3.3V DC.</p> <p>For a 5V tolerant I/O, connect pins to a +3.3V DC.</p> <p>NOTE: For power sequencing requirements please see Device Power Up on page 63.</p>
22	DATA_ERROR	Synchronous with PCLK	Output	<p>STATUS SIGNAL OUTPUT. Signal levels are LVCMOS / LVTTTL compatible.</p> <p>The DATA_ERROR signal will be LOW when an error within the received data stream has been detected by the device. This pin is an inverted logical 'OR'ing of all detectable errors listed in the internal ERROR_STATUS register.</p> <p>Once an error is detected, DATA_ERROR will remain LOW until the start of the next video frame / field, or until the ERROR_STATUS register is read via the host interface.</p> <p>The DATA_ERROR signal will be HIGH when the received data stream has been detected without error.</p> <p>NOTE: It is possible to program which error conditions are monitored by the device by setting appropriate bits in the ERROR_MASK register HIGH. All error conditions are detected by default.</p>
23, 25, 26, 27	STAT[0:3]	Synchronous with PCLK or RD_CLK	Output	<p>MULTI FUNCTION I/O PORT Signal levels are LVCMOS / LVTTTL compatible.</p> <p>Programmable multi-function outputs. By programming the bits in the IO_CONFIG register, each pin can output one of the following signals:</p> <ul style="list-style-type: none"> • H • V • F • $\overline{\text{FIFO_LD}}$ • ANC_DETECT • EDH_DETECT • FIFO_FULL • FIFO_EMPTY <p>These pins are set to certain default values depending on the configuration of the device and the internal FIFO mode selected. See Programmable Multi-Function Outputs on page 56 for details.</p>
24, 28, 42	IO_GND	Non Synchronous	Input Power	<p>Ground connection for digital I/O. Connect to GND.</p>

Table 1-1: Pin List and Description (Continued)

30	RD_CLK	–	Input	FIFO READ CLOCK Signal levels are LVCMOS / LVTTTL compatible. The parallel data will be clocked out of the FIFO on the rising edge of RD_CLK.
31	$\overline{\text{RD_RESET}}$	Synchronous with RD_CLK	Input	FIFO READ RESET Signal levels are LVCMOS / LVTTTL compatible. Valid input only when the device is in SMPTE mode ($\overline{\text{SMPTE_BYPASS}} = \text{HIGH}$ and DVB-ASI = LOW), and the internal FIFO is configured for video mode (See Video Mode on page 47). A HIGH to LOW transition will reset the FIFO pointer to address zero of the memory.
32 - 41	DOUT[0:9]	Synchronous with RD_CLK or PCLK	Output	PARALLEL VIDEO DATA BUS Signal levels are LVCMOS / LVTTTL compatible. When the internal FIFO is enabled and configured for either video mode or DVB-ASI mode, parallel data will be clocked out of the device on the rising edge of RD_CLK. When the internal FIFO is in bypass mode, parallel data will be clocked out of the device on the rising edge of PCLK. DOUT9 is the MSB and DOUT0 is the LSB.
44	PCLK	–	Output	PIXEL CLOCK OUTPUT Signal levels are LVCMOS / LVTTTL compatible. 27MHz parallel clock output.
46	LOCKED	Synchronous with PCLK	Output	STATUS SIGNAL OUTPUT Signal levels are LVCMOS / LVTTTL compatible. The LOCKED signal will be HIGH whenever the device has correctly received and locked to SMPTE compliant data in SMPTE mode or DVB-ASI compliant data in DVB-ASI mode, or when the reclocker has achieved lock in Data-Through mode. It will be LOW otherwise. When the signal is LOW, all digital output signals will be forced to logic LOW levels.
47	DVB_ASI	Non Synchronous	Input / Output	CONTROL SIGNAL INPUT / STATUS SIGNAL OUTPUT Signal levels are LVCMOS / LVTTTL compatible. This pin is an input in Manual mode, and an output set by the device in Auto mode. Auto Mode ($\overline{\text{AUTO/MAN}} = \text{HIGH}$): The DVB_ASI signal will be HIGH only when the device has locked to a DVB-ASI compliant data stream. It will be LOW otherwise. Manual Mode ($\overline{\text{AUTO/MAN}} = \text{LOW}$): When this pin is set HIGH, the device will be configured to operate in DVB-ASI mode. The $\overline{\text{SMPTE_BYPASS}}$ pin will be ignored. When set LOW, the device will not support the decoding or word alignment of received DVB-ASI data.

Table 1-1: Pin List and Description (Continued)

49	$\overline{\text{SMPTE_BYPASS}}$	Non Synchronous	Input / Output	<p>CONTROL SIGNAL INPUT / STATUS SIGNAL OUTPUT Signal levels are LVCMOS / LVTTTL compatible.</p> <p>This pin is an input in Manual mode, and an output set by the device in Auto mode.</p> <p>Auto Mode ($\overline{\text{AUTO/MAN}} = \text{HIGH}$): The $\overline{\text{SMPTE_BYPASS}}$ signal will be HIGH only when the device has locked to a SMPTE compliant data stream. It will be LOW otherwise. When the signal is LOW, no I/O processing features are available.</p> <p>Manual Mode ($\overline{\text{AUTO/MAN}} = \text{LOW}$): When this pin is set HIGH in conjunction with $\text{DVB_ASI} = \text{LOW}$, the device will be configured to operate in SMPTE mode. All I/O processing features may be enabled in this mode.</p> <p>When the $\overline{\text{SMPTE_BYPASS}}$ pin is set LOW, the device will not support the descrambling, decoding, or word alignment of received SMPTE data. No I/O processing features will be available.</p>
50	$\overline{\text{AUTO/MAN}}$	Non Synchronous	Input	<p>CONTROL SIGNAL INPUT Signal levels are LVCMOS / LVTTTL compatible.</p> <p>When set HIGH, the GS9090B will operate in Auto mode. The DVB_ASI and $\overline{\text{SMPTE_BYPASS}}$ pins become output status signals set by the device. In this mode, the GS9090B will automatically detect, relock, deserialize, and process SMPTE or DVB-ASI compliant input data.</p> <p>When set LOW, the GS9090B will operate in Manual mode. The DVB_ASI and $\overline{\text{SMPTE_BYPASS}}$ pins become input control signals. In this mode, these two external pins must be set for the correct reception of either SMPTE or DVB-ASI data. Manual mode also supports the relocking and deserializing of data not conforming to SMPTE or DVB-ASI streams.</p>
51	FW_EN	Non Synchronous	Input	<p>CONTROL SIGNAL INPUT Signal levels are LVCMOS / LVTTTL compatible.</p> <p>Used to enable or disable the noise immune flywheel of the device.</p> <p>When set HIGH, the internal flywheel is enabled. This flywheel is used in the extraction of timing signals, the generation of TRS signals, the automatic detection of video standards, and in manual switch line lock handling.</p> <p>When set LOW, the internal flywheel is disabled. Timing based TRS errors will not be detected.</p>
52	FIFO_EN	Non Synchronous	Input	<p>CONTROL SIGNAL INPUT Signal levels are LVCMOS / LVTTTL compatible.</p> <p>Used to enable / disable the internal FIFO.</p> <p>When FIFO_EN is HIGH, the internal FIFO will be enabled. Data will be clocked out of the device on the rising edge of the RD_CLK input pin if the FIFO is in video mode or DVB-ASI mode.</p> <p>When FIFO_EN is LOW, the internal FIFO is bypassed and parallel data is clocked out on the rising edge of the PCLK output.</p>

Table 1-1: Pin List and Description (Continued)

53	VCO_VDD	Analog	Input Power	Power supply connection for Voltage-Controlled-Oscillator. Connect to +1.8V DC.
54	LB_CONT	Analog	Input	CONTROL SIGNAL INPUT Control voltage to fine-tune the loop bandwidth of the PLL.
55	VCO_GND	Analog	Input Power	Ground connection for Voltage-Controlled-Oscillator. Connect to GND.
56	LF+	Analog	Input	Loop filter component connection. Connect to pin 1 (LF-) as shown in Typical Application Circuit (Part B) on page 67 .
–	Center Pad	–	Power	Connect to GND following recommendations in Recommended PCB Footprint on page 69

2. Electrical Characteristics

2.1 Absolute Maximum Ratings

Table 2-1: Absolute Maximum Ratings

Parameter	Value/Units
Supply Voltage Core	-0.3V to +2.1V
Supply Voltage I/O	-0.3V to +3.47V
Input Voltage Range (any input)	-2.0V to + 5.25V
Ambient Operating Temperature	$-20^{\circ}\text{C} \leq T_A \leq 85^{\circ}\text{C}$
Storage Temperature	$-40^{\circ}\text{C} \leq T_{\text{STG}} \leq 125^{\circ}\text{C}$
ESD protection on all pins (see Note 1)	1kV
Solder Reflow Temperature	260°C

NOTES:

1. HBM, per JESD22 - A114B

Absolute Maximum Ratings are those values beyond which damage to the device may occur. Functional operation under these conditions or at any other condition beyond those indicated in the AC/DC Electrical Characteristic sections is not implied.

2.2 DC Characteristics

Table 2-2: DC Electrical Characteristics

$V_{\text{DD}} = 1.8\text{V} \pm 5\%$, $3.3\text{V} \pm 5\%$; $T_A = 0^{\circ}\text{C}$ to 70°C , unless otherwise specified. Typical values: $V_{\text{CC}} = 1.8\text{V}$, 3.3V and $T_A = 25^{\circ}\text{C}$

Parameter	Symbol	Condition	Min	Typ	Max	Units	Notes
System							
Core Power Supply Voltage	CORE_VDD	–	1.71	1.8	1.89	V	–
Digital I/O Buffer Power Supply Voltage	IO_VDD	1.8V Operation	1.71	1.8	1.89	V	–
		3.3V Operation	3.13	3.3	3.47	V	–
PLL Power Supply Voltage	PLL_VDD	–	1.71	1.8	1.89	V	–
VCO Power Supply Voltage	VCO_VDD	–	1.71	1.8	1.89	V	–
Typical System Power	P_D	CORE_VDD = 1.8V IO_VDD = 1.8V T = 25°C	–	145	–	mW	–

Table 2-2: DC Electrical Characteristics (Continued)

V_{DD} = 1.8V ±5%, 3.3V ±5%; T_A = 0°C to 70°C, unless otherwise specified. Typical values: V_{CC} = 1.8V, 3.3V and T_A = 25°C

Parameter	Symbol	Condition	Min	Typ	Max	Units	Notes
Max. System Power	P _D	CORE_VDD = 1.89V IO_VDD = 3.47V T = 70°C	–	–	270	mW	–
Digital I/O							
Input Voltage, Logic LOW	V _{IL}	1.8V Operation or 3.3V Operation	–	–	0.35 x IO_VDD	V	–
Input Voltage, Logic HIGH	V _{IH}	1.8V Operation or 3.3V Operation	0.65 x IO_VDD	–	–	V	–
Output Voltage, Logic LOW	V _{OL}	I _{OL} = 8mA @ 3.3V, 4mA @ 1.8V	–	–	0.4	V	–
Output Voltage, Logic HIGH	V _{OH}	I _{OL} = -8mA @ 3.3V, -4mA @ 1.8V	IO_VDD - 0.4	–	–	V	–
Serial Digital Inputs							
Input Common Mode Voltage	V _{CMIN}	BUFF_VDD connected to 3.3V supply	BUFF_GND + (V _{DIFF} / 2)	–	BUFF_VDD - (V _{DIFF} / 2)	V	–
Input Termination Resistance	R _{IN}	–	37.5	50	62.5	Ω	–

2.3 AC Electrical Characteristics

Table 2-3: AC Electrical Characteristics

V_{DD} = 1.8V ±5%, 3.3V ±5%; T_A = 0°C to 70°C, unless otherwise specified. Typical values: V_{CC} = 1.8V, 3.3V and T_A = 25°C

Parameter	Symbol	Condition	Min	Typ	Max	Units	Notes
System							
Asynchronous Lock Time (LOCKED signal set HIGH)	t _{LOCK}	Input jitter of 0.2UI, No data to SMPTE, SMPTE_BYPASS = HIGH, DVB_ASI = LOW, at 25°C	–	–	235	us	1
Asynchronous Lock Time (LOCKED signal set HIGH)	t _{LOCK}	Input jitter of 0.2UI, No data to non-SMPTE, SMPTE_BYPASS = LOW, DVB_ASI = LOW, at 25°C	–	–	165	us	1

Table 2-3: AC Electrical Characteristics (Continued)

$V_{DD} = 1.8V \pm 5\%$, $3.3V \pm 5\%$; $T_A = 0^\circ C$ to $70^\circ C$, unless otherwise specified. Typical values: $V_{CC} = 1.8V$, $3.3V$ and $T_A = 25^\circ C$

Parameter	Symbol	Condition	Min	Typ	Max	Units	Notes
Serial Digital Input							
Serial Input Data Rate	DR _{SDI}	–	–	270	–	Mb/s	–
DVB-ASI Payload Data Rate	DR _{ASI}	204 byte mode	–	–	213.9	Mb/s	2,4
		188 byte mode	–	–	213.7	Mb/s	3,4
Serial Input Jitter Tolerance	IJT	–	–	0.5	–	UI	5
Differential Input Voltage Range	–	BUFF_VDD = 1.8V	200	800	1700	mV _{p-p}	–
		BUFF_VDD = 3.3V	100	800	2200	mV _{p-p}	–
Parallel Output							
Parallel Output Clock Frequency	f _{PCLK}	–	–	27	–	MHz	–
Parallel Output Clock Duty Cycle	DC _{PCLK}	–	40	–	60	%	–
Variation of Parallel Output Clock (from 27MHz)	–	Device Unlocked	-7.5	–	+7.5	%	6
Output Data Hold Time	t _{OH}	With 15pF load	3	–	–	ns	7
Output Delay Time	t _{OD}	With 15pF load	–	–	10	ns	7
GSPI							
GSPI Input Clock Frequency	f _{GSPI}	–	–	–	54	MHz	–
GSPI Clock Duty Cycle	DC _{GSPI}	–	40	–	60	%	–
GSPI Setup Time	t _{GS}	–	1.5	–	–	ns	–
GSPI Hold Time	t _{GH}	–	–	–	1.5	ns	–

NOTES

1. No signal to signal present, or a switch from another data rate to 270Mb/s.
2. Transmission format includes 204 byte data packets preceded by two K28.5 synchronization characters. Payload data rate excludes the two K28.5 synchronization characters.
3. Transmission format includes 188 byte data packets preceded by two K28.5 synchronization characters. Payload data rate excludes the two K28.5 synchronization characters.
4. Maximum payload is achieved via data packet mode, however, any combination of burst and packet mode is supported as long as each byte or packet is preceded by two K28.5 characters.
5. Power supply noise 50mV_{pp} at 15kHz, 100kHz, 1MHz sinusoidal modulation.
6. When the serial input to the GS9090B is removed, the PCLK output signal will continue to operate at 27MHz and the internal VCO will remain at this frequency within +/-7.5%.
7. Timing includes the following outputs: DOUT[9:0], H, V, F, ANC, EDH_DETECT, FIFO_FULL, FIFO_EMPTY, FIFO_LD, WORDERR, SYNCOUT. When the FIFO is enabled, the outputs are measured with respect to RD_CLK.

2.4 Solder Reflow Profiles

The device is manufactured with Matte-Sn terminations and is compatible with both standard eutectic and Pb-free solder reflow profiles. MSL qualification was performed using the maximum Pb-free reflow profile shown in Figure 2-1. The recommended standard eutectic reflow profile is shown in Figure 2-2.

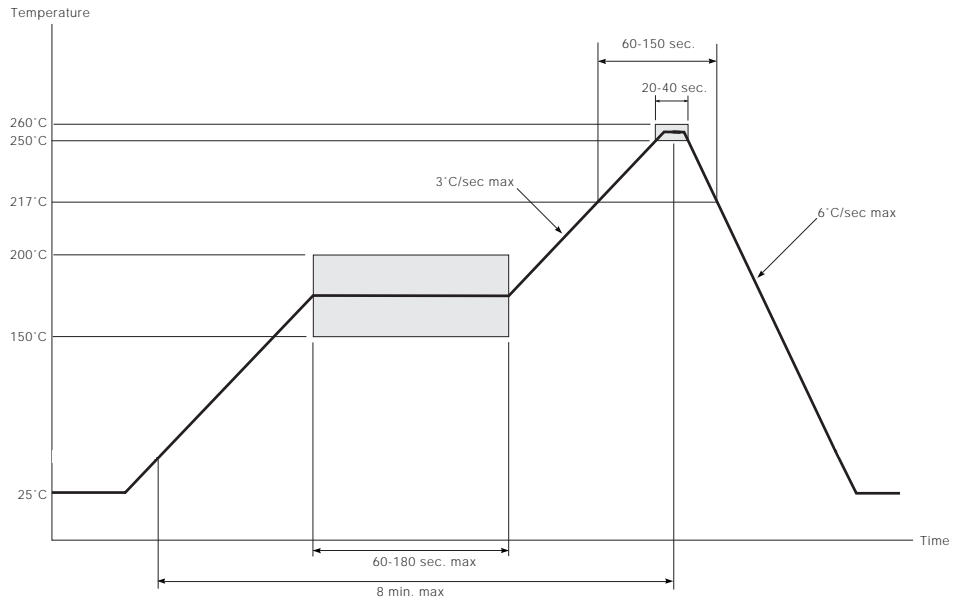

Figure 2-1: Maximum Pb-free Solder Reflow Profile (Preferred)

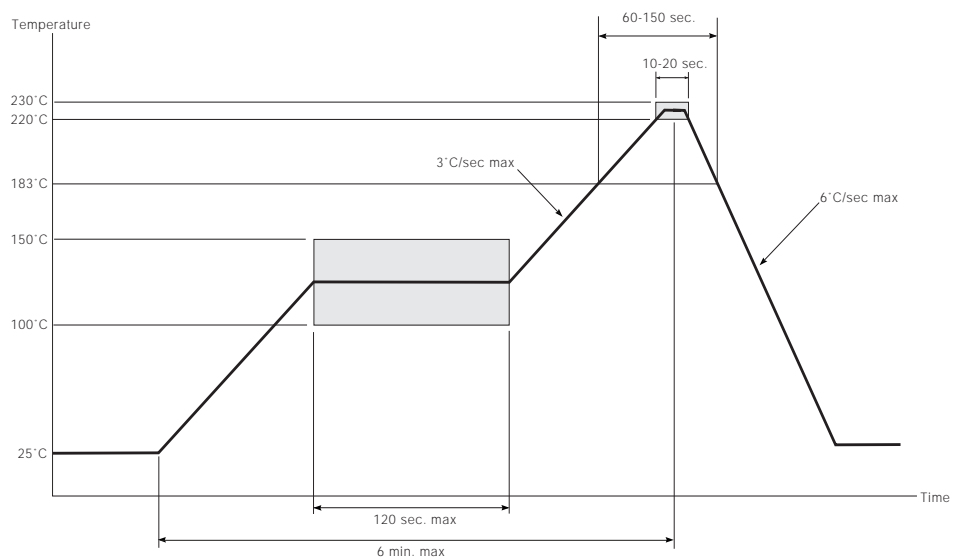

Figure 2-2: Standard Pb Solder Reflow Profile

2.5 Host Interface Map

Table 2-4: Host Interface Map

Register Name	Address	15	14	13	12	11	10	9	8	7	6	5	4	3	2	1	0
FF0_LD_POSITION[12:0]	28h	Not Used	Not Used	Not Used	b12	b11	b10	b9	b8	b7	b6	b5	b4	b3	b2	b1	b0
	27h																
	28h																
ERROR_MASK_REGISTER	25h	Not Used	Not Used	Not Used	Not Used	Not Used	Not Used	Not Used	Not Used	Not Used	Not Used	Not Used	Not Used	Not Used	Not Used	Not Used	Not Used
FF_PIXEL_END_F0[12:0]	24h	Not Used	Not Used	Not Used	b12	b11	b10	b9	b8	b7	b6	b5	b4	b3	b2	b1	b0
FF_PIXEL_START_F1[12:0]	23h	Not Used	Not Used	Not Used	b12	b11	b10	b9	b8	b7	b6	b5	b4	b3	b2	b1	b0
FF_PIXEL_END_F0[12:0]	22h	Not Used	Not Used	Not Used	b12	b11	b10	b9	b8	b7	b6	b5	b4	b3	b2	b1	b0
FF_PIXEL_START_F0[12:0]	21h	Not Used	Not Used	Not Used	b12	b11	b10	b9	b8	b7	b6	b5	b4	b3	b2	b1	b0
AP_PIXEL_END_F1[12:0]	20h	Not Used	Not Used	Not Used	b12	b11	b10	b9	b8	b7	b6	b5	b4	b3	b2	b1	b0
AP_PIXEL_START_F1[12:0]	1Fh	Not Used	Not Used	Not Used	b12	b11	b10	b9	b8	b7	b6	b5	b4	b3	b2	b1	b0
AP_PIXEL_END_F0[12:0]	1Eh	Not Used	Not Used	Not Used	b12	b11	b10	b9	b8	b7	b6	b5	b4	b3	b2	b1	b0
AP_PIXEL_START_F0[12:0]	1Dh	Not Used	Not Used	Not Used	b12	b11	b10	b9	b8	b7	b6	b5	b4	b3	b2	b1	b0
FF_LINE_END_F1[10:0]	1Ch	Not Used	Not Used	Not Used	Not Used	Not Used	b10	b9	b8	b7	b6	b5	b4	b3	b2	b1	b0
FF_LINE_START_F1[10:0]	1Bh	Not Used	Not Used	Not Used	Not Used	Not Used	b10	b9	b8	b7	b6	b5	b4	b3	b2	b1	b0
FF_LINE_END_F0[10:0]	1Ah	Not Used	Not Used	Not Used	Not Used	Not Used	b10	b9	b8	b7	b6	b5	b4	b3	b2	b1	b0
FF_LINE_START_F0[10:0]	19h	Not Used	Not Used	Not Used	Not Used	Not Used	b10	b9	b8	b7	b6	b5	b4	b3	b2	b1	b0
AP_LINE_END_F1[10:0]	18h	Not Used	Not Used	Not Used	Not Used	Not Used	b10	b9	b8	b7	b6	b5	b4	b3	b2	b1	b0
AP_LINE_START_F1[10:0]	17h	Not Used	Not Used	Not Used	Not Used	Not Used	b10	b9	b8	b7	b6	b5	b4	b3	b2	b1	b0
AP_LINE_END_F0[10:0]	16h	Not Used	Not Used	Not Used	Not Used	Not Used	b10	b9	b8	b7	b6	b5	b4	b3	b2	b1	b0
AP_LINE_START_F0[10:0]	15h	Not Used	Not Used	Not Used	Not Used	Not Used	b10	b9	b8	b7	b6	b5	b4	b3	b2	b1	b0
RASTER_STRUCTURE4[10:0]	14h	Not Used	Not Used	Not Used	Not Used	Not Used	b10	b9	b8	b7	b6	b5	b4	b3	b2	b1	b0
RASTER_STRUCTURE3[12:0]	13h	Not Used	Not Used	Not Used	b12	b11	b10	b9	b8	b7	b6	b5	b4	b3	b2	b1	b0

Table 2-4: Host Interface Map (Continued)

Register Name	Address	15	14	13	12	11	10	9	8	7	6	5	4	3	2	1	0
RASTER_STRUCTURE[12:0]	12h	Not Used	Not Used	Not Used	b12	b11	b10	b9	b8	b7	b6	b5	b4	b3	b2	b1	b0
RASTER_STRUCTURE[10:0]	11h	Not Used	Not Used	Not Used	Not Used	Not Used	b10	b9	b8	b7	b6	b5	b4	b3	b2	b1	b0
VIDEO_FORMAT_OUT_B[4:3]	10h	VFO4-b7	VFO4-b6	VFO4-b5	VFO4-b4	VFO4-b3	VFO4-b2	VFO4-b1	VFO4-b0	VFO3-b7	VFO3-b6	VFO3-b5	VFO3-b4	VFO3-b3	VFO3-b2	VFO3-b1	VFO3-b0
VIDEO_FORMAT_OUT_A[2:1]	0fh	VFO2-b7	VFO2-b6	VFO2-b5	VFO2-b4	VFO2-b3	VFO2-b2	VFO2-b1	VFO2-b0	VFO1-b7	VFO1-b6	VFO1-b5	VFO1-b4	VFO1-b3	VFO1-b2	VFO1-b1	VFO1-b0
ANC_TYPE[5][15:0]	0Eh	b15	b14	b13	b12	b11	b10	b9	b8	b7	b6	b5	b4	b3	b2	b1	b0
ANC_TYPE[4][15:0]	0Dh	b15	b14	b13	b12	b11	b10	b9	b8	b7	b6	b5	b4	b3	b2	b1	b0
ANC_TYPE[3][15:0]	0Ch	b15	b14	b13	b12	b11	b10	b9	b8	b7	b6	b5	b4	b3	b2	b1	b0
ANC_TYPE[2][15:0]	0Bh	b15	b14	b13	b12	b11	b10	b9	b8	b7	b6	b5	b4	b3	b2	b1	b0
ANC_TYPE[1][15:0]	0Ah	b15	b14	b13	b12	b11	b10	b9	b8	b7	b6	b5	b4	b3	b2	b1	b0
ANC_LINE_B[100]	09h	Not Used	Not Used	Not Used	Not Used	Not Used	b10	b9	b8	b7	b6	b5	b4	b3	b2	b1	b0
ANC_LINE_A[100]	08h	Not Used	Not Used	Not Used	Not Used	Not Used	b10	b9	b8	b7	b6	b5	b4	b3	b2	b1	b0
FIFO_FULL_OFFSET	07h	Not Used	Not Used	Not Used	Not Used	Not Used	Not Used	b9	b8	b7	b6	b5	b4	b3	b2	b1	b0
FIFO_EMPTY_OFFSET	06h	Not Used	Not Used	Not Used	Not Used	ANC_DATA_DELETE	Not Used	b9	b8	b7	b6	b5	b4	b3	b2	b1	b0
IO_CONFIG	05h	Not Used	Not Used	Not Used	ANC_DATA_SWITCH	ANC_STAT3_CONFIG_b2	ANC_STAT3_CONFIG_b1	STAT3_CONFIG_b0	STAT2_CONFIG_b0	STAT2_CONFIG_b1	STAT2_CONFIG_b0	STAT1_CONFIG_b2	STAT1_CONFIG_b1	STAT1_CONFIG_b0	STAT0_CONFIG_b2	STAT0_CONFIG_b1	STAT0_CONFIG_b0
DATA_FORMAT	04h	Not Used	Not Used	Not Used	EDH_FLAG_UPDATE	EDH_FLAG_UPDATE	AP_CRC_V	FF_CRC_V	EDH_DETECT	VERSION_32M	Not Used	Not Used	STD_LOCK	DATA_FORMAT_b3	DATA_FORMAT_b2	DATA_FORMAT_b1	DATA_FORMAT_b0
EDH_FLAG_OUT	03h	Not Used	ANC_UES	ANC_IDA	ANC_IDH	ANC_EDA	ANC_EDH	FF_UES	FF_IDA	FF_IDH	FF_EDA	FF_EDH	AP_UES	AP_IDA	AP_IDH	AP_EDA	AP_EDH
EDH_FLAG_IN	02h	Not Used	ANC_UJ	ANC_IDA	ANC_IDH	ANC_EDA	ANC_EDH	FF_UES_IN	FF_IDA_IN	FF_IDH_IN	FF_EDA_IN	FF_EDH_IN	AP_UES_IN	AP_IDA_IN	AP_IDH_IN	AP_EDA_IN	AP_EDH_IN
ERROR_STATUS	01h	Not Used	Not Used	Not Used	Not Used	Not Used	Not Used	Not Used	Not Used	Not Used	VD_STD_ERR	FF_CRC_ERR	AP_CRC_ERR	LOCK_ERR	CCS_ERR	SAV_ERR	EAV_ERR
IOPROC_DISABLE	00h	Not Used	Not Used	Not Used	Not Used	Not Used	ANC_PRT_EXT	ANC_PRT_EXT	FIFO_MODE_b1	FIFO_MODE_b0	H_CONFIG	Not Used	Not Used	ILLEGAL_REMAP	EDH_CR_C_INS	ANC_CSUM_INS	TRS_IN

NOTE: Addresses 02Ch to 42Bh store the contents of the internal FIFO. The contents may be accessed in Ancillary Data Extraction mode (see Section 3.10.3).

2.5.1 Host Interface Map (R/W registers)

Table 2-5: Host Interface Map (R/W registers)

Register Name	Address	15	14	13	12	11	10	9	8	7	6	5	4	3	2	1	0
FIFO_ID_POSITION[12:0]	28h				b12	b11	b10	b9	b8	b7	b6	b5	b4	b3	b2	b1	b0
27h																	
26h																	
ERROR_MASK_REGISTER	25h										VD_STD_ERR_MASK	FF_CRC_ERR_MASK	AP_CRC_ERR_MASK	LOCK_ERR_MASK	CCS_ERR_MASK	SAV_ERR_MASK	EAV_ERR_MASK
FF_PIXEL_END_F0[12:0]	24h				b12	b11	b10	b9	b8	b7	b6	b5	b4	b3	b2	b1	b0
FF_PIXEL_START_F1[12:0]	23h				b12	b11	b10	b9	b8	b7	b6	b5	b4	b3	b2	b1	b0
FF_PIXEL_END_F0[12:0]	22h				b12	b11	b10	b9	b8	b7	b6	b5	b4	b3	b2	b1	b0
FF_PIXEL_START_F0[12:0]	21h				b12	b11	b10	b9	b8	b7	b6	b5	b4	b3	b2	b1	b0
AP_PIXEL_END_F1[12:0]	20h				b12	b11	b10	b9	b8	b7	b6	b5	b4	b3	b2	b1	b0
AP_PIXEL_START_F1[12:0]	1Fh				b12	b11	b10	b9	b8	b7	b6	b5	b4	b3	b2	b1	b0
AP_PIXEL_END_F0[12:0]	1Eh				b12	b11	b10	b9	b8	b7	b6	b5	b4	b3	b2	b1	b0
AP_PIXEL_START_F0[12:0]	1Dh				b12	b11	b10	b9	b8	b7	b6	b5	b4	b3	b2	b1	b0
FF_LINE_END_F1[10:0]	1Ch						b10	b9	b8	b7	b6	b5	b4	b3	b2	b1	b0
FF_LINE_START_F1[10:0]	1Bh						b10	b9	b8	b7	b6	b5	b4	b3	b2	b1	b0
FF_LINE_END_F0[10:0]	1Ah						b10	b9	b8	b7	b6	b5	b4	b3	b2	b1	b0
FF_LINE_START_F0[10:0]	19h						b10	b9	b8	b7	b6	b5	b4	b3	b2	b1	b0
AP_LINE_END_F1[10:0]	18h						b10	b9	b8	b7	b6	b5	b4	b3	b2	b1	b0
AP_LINE_START_F1[10:0]	17h						b10	b9	b8	b7	b6	b5	b4	b3	b2	b1	b0
AP_LINE_END_F0[10:0]	16h						b10	b9	b8	b7	b6	b5	b4	b3	b2	b1	b0
AP_LINE_START_F0[10:0]	15h						b10	b9	b8	b7	b6	b5	b4	b3	b2	b1	b0
14h																	
13h																	
12h																	

Table 2-5: Host Interface Map (R/W registers) (Continued)

Register Name	Address	15	14	13	12	11	10	9	8	7	6	5	4	3	2	1	0
	11h																
	10h																
	0Fh																
ANC_TYPE(5)[15:0]	0Eh	b15	b14	b13	b12	b11	b10	b9	b8	b7	b6	b5	b4	b3	b2	b1	b0
ANC_TYPE(4)[15:0]	0Dh	b15	b14	b13	b12	b11	b10	b9	b8	b7	b6	b5	b4	b3	b2	b1	b0
ANC_TYPE(3)[15:0]	0Ch	b15	b14	b13	b12	b11	b10	b9	b8	b7	b6	b5	b4	b3	b2	b1	b0
ANC_TYPE(2)[15:0]	0Bh	b15	b14	b13	b12	b11	b10	b9	b8	b7	b6	b5	b4	b3	b2	b1	b0
ANC_TYPE(1)[15:0]	0Ah	b15	b14	b13	b12	b11	b10	b9	b8	b7	b6	b5	b4	b3	b2	b1	b0
ANC_LINE_B[100]	09h						b10	b9	b8	b7	b6	b5	b4	b3	b2	b1	b0
ANC_LINE_A[100]	08h						b10	b9	b8	b7	b6	b5	b4	b3	b2	b1	b0
FIFO_FULL_OFFSET	07h							b9	b8	b7	b6	b5	b4	b3	b2	b1	b0
FIFO_EMPTY_OFFSET	06h					ANC_DATA_DELETE		b9	b8	b7	b6	b5	b4	b3	b2	b1	b0
IO_CONFIG	05h			ANC_DATA_SWITCH	ANC_DATA_SWITCH	STAT3_CONFIG_b2	STAT3_CONFIG_b1	STAT3_CONFIG_b0	STAT2_CONFIG_b2	STAT2_CONFIG_b1	STAT2_CONFIG_b0	STAT1_CONFIG_b2	STAT1_CONFIG_b1	STAT1_CONFIG_b0	STAT0_CONFIG_b2	STAT0_CONFIG_b1	STAT0_CONFIG_b0
DATA_FORMAT	04h					EDH_FLAG_UPDATE											
	03h																
	02h																
	01h																
IOPROC_DISABLE	00h							ANC_PKT_EXT	FIFO_MODE_b1	FIFO_MODE_b0	H_L_CONFIG			ILLEGAL_REMAP	EDH_CR_CINS	ANC_CSJML_INS	TRF_IN

NOTE: Addresses 02Ch to 42Bh store the contents of the internal FIFO. The contents may be accessed in Ancillary Data Extraction mode (see Section 3.10.3).

2.5.2 Host Interface Map (Read only registers)

Table 2-6: Host Interface Map (Read only registers)

Register Name	Address	15	14	13	12	11	10	9	8	7	6	5	4	3	2	1	0
	28h																
	27h																
	26h																
	25h																
	24h																
	23h																
	22h																
	21h																
	20h																
	1Fh																
	1Eh																
	1Dh																
	1Ch																
	1Bh																
	1Ah																
	19h																
	18h																
	17h																
	16h																
	15h																
RASTER_STRUCTURE4[10:0]	14h						b10	b9	b8	b7	b6	b5	b4	b3	b2	b1	b0
RASTER_STRUCTURE3[12:0]	13h			b12		b11	b10	b9	b8	b7	b6	b5	b4	b3	b2	b1	b0
RASTER_STRUCTURE2[12:0]	12h			b12		b11	b10	b9	b8	b7	b6	b5	b4	b3	b2	b1	b0
RASTER_STRUCTURE1[10:0]	11h						b10	b9	b8	b7	b6	b5	b4	b3	b2	b1	b0

Table 2-6: Host Interface Map (Read only registers) (Continued)

Register Name	Address	15	14	13	12	11	10	9	8	7	6	5	4	3	2	1	0
VIDEO_FORMAT_OUT_B(4:3)	10h	VFO4-b7	VFO4-b6	VFO4-b5	VFO4-b4	VFO4-b3	VFO4-b2	VFO4-b1	VFO4-b0	VFO3-b7	VFO3-b6	VFO3-b5	VFO3-b4	VFO3-b3	VFO3-b2	VFO3-b1	VFO3-b0
VIDEO_FORMAT_OUT_A(2:1)	0Fh	VFO2-b7	VFO2-b6	VFO2-b5	VFO2-b4	VFO2-b3	VFO2-b2	VFO2-b1	VFO2-b0	VFO1-b7	VFO1-b6	VFO1-b5	VFO1-b4	VFO1-b3	VFO1-b2	VFO1-b1	VFO1-b0
	0Eh																
	0Dh																
	0Ch																
	0Bh																
	0Ah																
	09h																
	08h																
	07h																
	06h																
	05h																
DATA_FORMAT	04h						AP_CRC_V	FF_CRC_V	EDH_DETECT	VERSION_352M			STD_LOCK	DATA_FORMAT_b3	DATA_FORMAT_b2	DATA_FORMAT_b1	DATA_FORMAT_b0
EDH_FLAG_OUT	03h	Not Used	ANC_UES	ANC_IDA	ANC_IDH	ANC_EDA	ANC_EDH	FF_UES	FF_IDA	FF_IDH	FF_EDA	FF_EDH	AP_UES	AP_IDA	AP_IDH	AP_EDA	AP_EDH
EDH_FLAG_IN	02h	Not Used	ANC_UES_IN	ANC_IDA_IN	ANC_IDH_IN	ANC_EDA_IN	ANC_EDH_IN	FF_UES_IN	FF_IDA_IN	FF_IDH_IN	FF_EDA_IN	FF_EDH_IN	AP_UES_IN	AP_IDA_IN	AP_IDH_IN	AP_EDA_IN	AP_EDH_IN
ERROR_STATUS	01h										VD_STD_ERR	FF_CRC_ERR	AP_CRC_ERR	LOOK_ERR	CCS_ERR	SW_ERR	EAV_ERR
	00h																

NOTE: Addresses 02Ch to 42Bh store the contents of the internal FIFO. The contents may be accessed in Ancillary Data Extraction mode (see Section 3.10.3).

3. Detailed Description

- [Functional Overview](#)
- [Serial Digital Input](#)
- [Clock and Data Recovery](#)
- [Serial-To-Parallel Conversion](#)
- [Modes Of Operation](#)
- [SMPTE Functionality](#)
- [DVB-ASI Functionality](#)
- [Data-Through Functionality](#)
- [Additional Processing Features](#)
- [Internal FIFO Operation](#)
- [Parallel Data Outputs](#)
- [Programmable Multi-Function Outputs](#)
- [GS9090B Low-latency Mode](#)
- [GSPI Host Interface](#)
- [JTAG Operation](#)
- [Device Power Up](#)

3.1 Functional Overview

The GS9090B is a 270Mb/s reclocking deserializer with an internal FIFO and programmable multi-function output port. The device has two basic modes of operation. In Auto mode, the GS9090B can automatically detect SMPTE or DVB-ASI data streams at its input. In Manual mode, the device can be set to process SMPTE or DVB/ASI data streams.

The digital signal processing core handles ancillary data detection/indication, error detection and handling (EDH), SMPTE352M extraction, and automatic video standards detection. These features are all enabled by default, but may be individually disabled via internal registers accessible through the GSPI host interface.

The provided programmable multi-function output pins may be configured to output various status signals including H, V, and F timing, ancillary data detection, EDH detection, and a FIFO load pulse. The internal FIFO supports 4 modes of operation, which may be used for data alignment, data delay, MPEG packet extraction, or ancillary data extraction.

The GS9090B contains a JTAG interface for boundary scan test implementations.

3.2 Serial Digital Input

The GS9090B contains a current mode differential serial digital input buffer. The input buffer has internal 50Ω termination resistors, which are connected to ground via the TERM pin.

If the input signal is AC coupled to the device, the signal source common mode level will be set internally to typically 1.45V. If the input signal is DC coupled to the device, the internal biasing will be ignored. Please see [AC Electrical Characteristics](#) for Common Mode range and swing characteristics.

3.3 Clock and Data Recovery

The GS9090B contains an integrated clock and data recovery block. The function of this block is to lock to the input data stream, extract a clean clock, and retime the serial digital data to remove high frequency jitter.

3.3.1 Internal VCO and Phase Detector

The GS9090B uses an internal VCO and PFD as part of the reclocker's phase-locked loop. Each block requires a +1.8V DC power supply, which is supplied via the VCO_VDD / VCO_GND and PLL_VDD / PLL_GND pins.

3.4 Serial-To-Parallel Conversion

The retimed data and phase-locked clock signals from the reclocker are fed to the serial-to-parallel converter. The function of this block is to extract 10-bit parallel data words from the reclocked serial data stream and simultaneously present them to the SMPTE and DVB-ASI word alignment blocks.

3.5 Modes Of Operation

The GS9090B has two basic modes of operation: Auto mode and Manual mode. Auto mode is enabled when $\overline{\text{AUTO/MAN}}$ is set HIGH, and Manual mode is enabled when $\overline{\text{AUTO/MAN}}$ is set LOW. As indicated in [Figure 3-1](#), each mode supports both SMPTE and DVB-ASI input signals. In addition, Data-Through functionality is possible when the GS9090B is in Manual mode.

In Auto mode ($\overline{\text{AUTO/MAN}} = \text{HIGH}$), the GS9090B will automatically detect, reclock, deserialize, and process SMPTE 259M-C, or DVB-ASI input data.

In Manual mode ($\overline{\text{AUTO/MAN}} = \text{LOW}$), the $\overline{\text{SMPTE_BYPASS}}$ and $\overline{\text{DVB_ASI}}$ pins must be set as per [Table 3-2](#) for the correct reception of either SMPTE or DVB-ASI data. Manual mode also supports the reclocking and deserializing of 270Mb/s data not conforming to SMPTE or DVB-ASI streams.

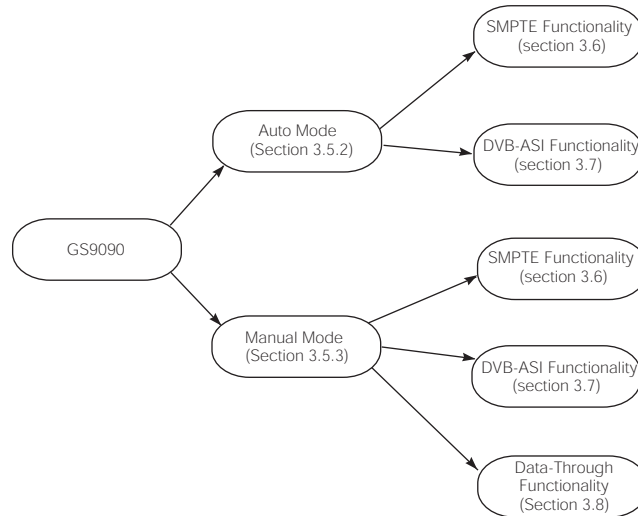

Figure 3-1: GS9090B's Modes of Operation

3.5.1 Lock Detect

Once the reclocker has locked to the received serial digital data stream, the lock detect block of the GS9090B searches for the appropriate sync words, and indicates via the LOCKED output pin when the device has successfully achieved lock. The LOCKED pin is designed to be stable. It will not toggle during the locking process, nor will it glitch during a SMPTE synchronous switch.

The lock detection process is summarized in [Figure 3-2](#).

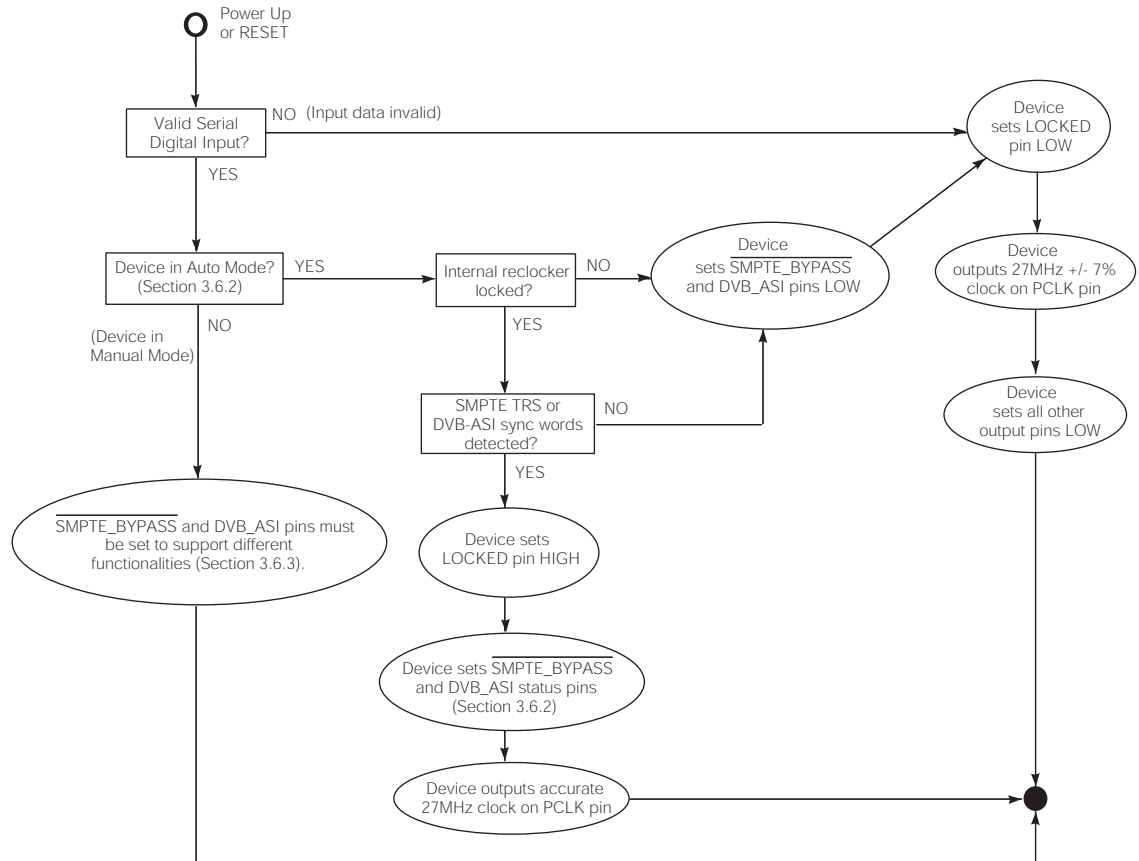

Figure 3-2: Lock Detection Process

The lock detection algorithm (Figure 3-2) first determines if the input is a 270Mb/s serial digital data stream.

When the serial data input signal is considered invalid, the LOCKED pin will be set LOW, and all device outputs will be forced LOW, except PCLK.

If a valid serial digital input signal has been detected, and the device is in Auto mode, the lock algorithm will attempt to detect the presence of either SMPTE TRS words or DVB-ASI sync words*. Assuming that a valid 270Mb/s SMPTE or DVB-ASI signal has been applied to the device, the LOCKED pin will be set HIGH.

The PCLK output frequency will be 27MHz +/- 7.5% when the device is not locked, as well as during the lock detection process.

* DVB-ASI sync words must be immediately followed by an MPEG packet header for word alignment to correctly function.

For serial inputs that do not conform to SMPTE or DVB-ASI formats, the device can only achieve the locked state in manual mode. In Auto mode, the LOCKED signal will be asserted LOW, the parallel outputs will be latched to logic LOW, and the SMPTE_BYPASS and DVB_ASI output signals will also be set LOW.

In Manual mode, the $\overline{\text{SMPTE_BYPASS}}$ and $\overline{\text{DVB_ASI}}$ input pins must be set LOW. If the GS9090B achieves lock to the input data signal, data will be passed directly to the parallel outputs without any further processing (see [Section 3.8](#)).

3.5.2 Auto Mode

The GS9090B is in Auto mode when the $\overline{\text{AUTO/MAN}}$ input pin is set HIGH. In this mode, $\overline{\text{SMPTE_BYPASS}}$ and $\overline{\text{DVB_ASI}}$ become output status pins, as shown in [Table 3-1](#).

Table 3-1: Auto Mode Output Status Signals

Format	Pin Settings	
	$\overline{\text{SMPTE_BYPASS}}$	$\overline{\text{DVB_ASI}}$
SD SMPTE	HIGH	LOW
DVB-ASI	LOW	HIGH
NOT SMPTE OR DVB-ASI*	LOW	LOW

*NOTE: In this case the device will not be locked (LOCKED = LOW), and all digital output pins except PCLK will be set LOW (see [Section 3.5.1](#))

3.5.3 Manual Mode

The GS9090B is in Manual mode when the $\overline{\text{AUTO/MAN}}$ input pin is set LOW. In this mode, the $\overline{\text{SMPTE_BYPASS}}$ and $\overline{\text{DVB_ASI}}$ pins become input signals, and the operating mode of the device is set by these pins as shown in [Table 3-2](#)

Table 3-2: Manual Mode Input Status Signals

Format	Pin Settings	
	$\overline{\text{SMPTE_BYPASS}}$	$\overline{\text{DVB_ASI}}$
SD SMPTE	HIGH	LOW
DVB-ASI	X	HIGH
NOT SMPTE OR DVB-ASI (Data-Through mode)*	LOW	LOW

*NOTE: See [Section 3.8](#) for more detail on Data-Through mode

3.6 SMPTE Functionality

The GS9090B is in SMPTE mode once the device has detected two SMPTE TRS sync words. The GS9090B will remain in SMPTE mode until six SMPTE TRS sync words fail to be detected.

TRS word detection is a continuous process, and the device will identify both 8-bit and 10-bit TRS words.

In Auto mode, the GS9090B sets the $\overline{\text{SMPTE_BYPASS}}$ pin HIGH and the DVB_ASI pin LOW to indicate that it has locked to a SMPTE input data stream. When operating in Manual mode, the DVB_ASI pin must be set LOW and the $\overline{\text{SMPTE_BYPASS}}$ pin must be set HIGH in order to enable SMPTE operation.

3.6.1 SMPTE Descrambling and Word Alignment

The GS9090B performs NRZI-to-NRZ decoding, descrambling according to SMPTE 259M-C, and word alignment of the data to the TRS sync words when in SMPTE mode.

NOTE: When 8-bit data is embedded into the SMPTE signal, the source must have the two LSBs of the 10-bit stream set to logic LOW in order for word alignment to function correctly.

3.6.2 Internal Flywheel

The GS9090B has an internal flywheel for the generation of internal / external timing signals, the detection and correction of certain error conditions, and the automatic detection of video standards. The flywheel is only operational in SMPTE mode.

The flywheel 'learns' the video standard by timing the horizontal and vertical reference information contained in the TRS ID words of the received video stream. The flywheel maintains information about the total line length, active line length, total number of lines per field / frame, and total active lines per field / frame for the received video stream. Full synchronization of the flywheel to the received video standard therefore requires one complete video frame.

Once synchronization has been achieved, the flywheel will continue to monitor the received TRS timing information to maintain synchronization.

The FW_EN input pin controls the synchronization mechanism of the flywheel. When this input signal is LOW, the flywheel will re-synchronize all pixel and line based counters on every received TRS ID word.

When FW_EN is set to logic HIGH, re-synchronization occurs when the flywheel detects three to four consecutive video lines containing mistimed TRS information. This provides a measure of noise immunity to internal and external timing signal generation.

The flywheel will be disabled if the device loses lock, or a LOW-to-HIGH transition occurs on the $\overline{\text{RESET}}$ pin.

3.6.3 Switch Line Lock Handling

The principle of switch line lock handling is that the switching of synchronous video sources will only disturb the horizontal timing and alignment of the stream, whereas the vertical timing remains in synchronization.

3.6.3.1 Automatic Switch Line Lock Handling

The GS9090B also implements automatic switch line lock handling. By utilizing both the synchronous switch point defined in SMPTE RP168, and the automatic video standards detect function, the device automatically re-synchronizes the flywheel at the switch point. This will occur whether or not the device has detected TRS word errors. Word alignment re-synchronization will also take place at this time.

Automatic switch line lock handling will occur regardless of the setting of the FW_EN pin.

The switch line is defined as follows:

- for 525 line interlaced systems: re-sync takes place at the end of lines 10 & 273
- for 625 line interlaced systems: re-sync takes place at the end of lines 6 & 319

A full list of 270Mb/s video standards and switching lines is shown in [Table 3-3](#).

At every PCLK cycle the device samples the FW_EN pin. When the FW_EN pin is set LOW anywhere within the active line, the flywheel will re-synchronize immediately to the next TRS word.

3.6.3.2 Manual Switch Line Lock Handling

The ability to manually re-synchronize the flywheel is also important when switching asynchronous sources or to implement other non-standardized video switching functions.

To account for the horizontal disturbance caused by a synchronous switch, it is necessary to re-synchronize the flywheel immediately after the switch has taken place. Rapid re-synchronization of the GS9090B to the new video standard can be achieved by disabling the flywheel (setting the FW_EN pin to logic LOW) after the switch, and re-enabling the flywheel after the next TRS word.

Table 3-3: Switch Line Position for 270MB/s Digital Systems

System	Video Format	Sampling	Signal Standard	Parallel Interface	Serial Interface	Switch Line Number
SDTI	720x576/50 (2:1)	4:2:2	BT.656	BT.656 + 305M	259M-C	6, 319
	720x483/59.94 (2:1)	4:2:2	125M	125M + 305M	259M-C	10, 273
525	720x483/59.94 (2:1)	4:2:2	125M	125M	259M-C	10, 273
625	720x576/50 (2:1)	4:2:2	BT.656	125M	259M-C	6, 319

3.6.4 HVF Timing Signal Generation

The GS9090B extracts timing parameters, and outputs them to the F, V and H pins, from either the received TRS signals (FW_EN = LOW) or from the internal flywheel-timing generator (FW_EN = HIGH).

Horizontal blanking period (H), vertical blanking period (V), and field odd / even timing (F) are extracted and are available for output on any of the multi-function output port pins, if so programmed (see Section 3.12).

The H signal timing is configurable via the H_CONFIG bit of the internal IOPROC_DISABLE register as either active line-based blanking, or TRS-based blanking (see Table 3-14 in Section 3.9.8).

Active line-based blanking is enabled when the H_CONFIG bit is set LOW. In this mode, the H output is HIGH for the entire horizontal blanking period, including the EAV and SAV TRS words. This is the default H timing used by the device.

When H_CONFIG is set HIGH, TRS based blanking is enabled. In this case, the H output will be HIGH for the entire horizontal blanking period as indicated by the H bit in the received TRS ID words.

The timing of these signals is shown in Figure 3-3.

NOTE 1: When the internal FIFO is configured for video mode, the H, V, and F signals will be timed to the data output from the FIFO (see Section 3.10.1).

NOTE 2: When the GS9090B is configured for Low-latency mode, the H, V, and F output timing will be TRS-based as shown in Section 3.13. Active line-based timing is not available in this mode, and the setting of the H_CONFIG host interface bit will be ignored.

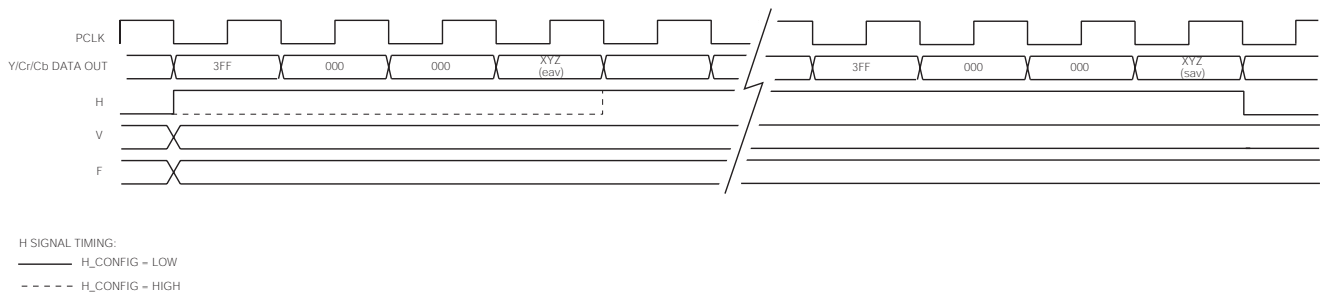

Figure 3-3: H,V,F Timing

3.7 DVB-ASI Functionality

The GS9090B is said to be in DVB-ASI mode once the device has detected 32 consecutive DVB-ASI words without a single word or disparity error being generated. The device will remain in DVB-ASI mode until 32 consecutive DVB-ASI word errors or disparity errors are detected

K28.5 sync characters in the received DVB-ASI data stream will be detected by the device in either inverted or non-inverted form.

In Auto mode, the GS9090B sets the `SMPTE_BYPASS` pin LOW and the `DVB_ASI` pin HIGH to indicate that it has locked to a DVB-ASI input data stream. When operating in Manual mode, the `DVB_ASI` pin must be set to logic HIGH in order to enable DVB-ASI operation. The input `SMPTE_BYPASS` pin will be ignored but should not be left floating.

When using DVB-ASI mode, the use of the application circuit in [Figure 3-4](#) is required. The use of this application circuit will prevent the internal PLL from false locking to a DVB-ASI signal harmonic rather than the 270MHz fundamental. This application circuit will detect the false lock state and restart the on-chip PLL. The application circuit does this by detecting if the `LOCKED` pin has been de-asserted for longer than $\sim 700\mu\text{s}$, and if so resets the PLL by discharging the loop filter capacitor through a CMOS switch.

The applications circuit below show how this can be implemented by using a STG719 switch as a reference. Other low leakage CMOS switches may also be substituted within the circuit.

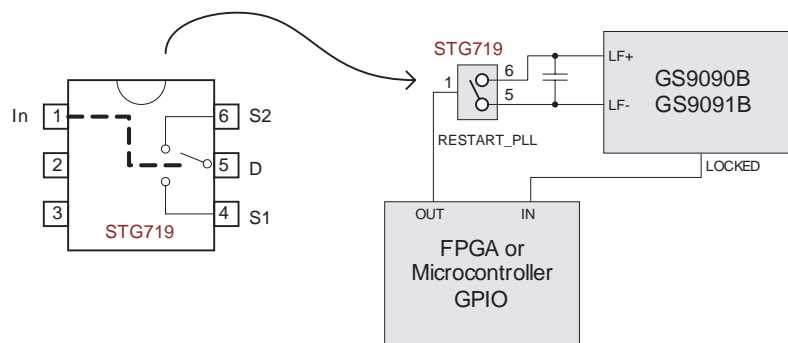

Figure 3-4: GS9090B False Lock Restart Circuit

The circuit above can be implemented using either a small state machine in an FPGA or general purpose I/O on a microcontroller in combination with some firmware. Typically, a system using the GS9090B will have an existing FPGA and/or microcontroller that may have some spare I/O that can be used to implement the false lock restart circuit. The choice of method will depend on what spare system resources are available. In either case, the waveform shown in [Figure 3-5 on page 31](#) represents how the PLL restart must be driven. The delay values of $700\mu\text{s}$ and $20\mu\text{s}$ are nominal but the values can be longer. In the case where the SDI inputs are not driven with a valid DVB-ASI signal, the

RESTART_PLL signal should be repeated indefinitely as long as LOCKED remains de-asserted.

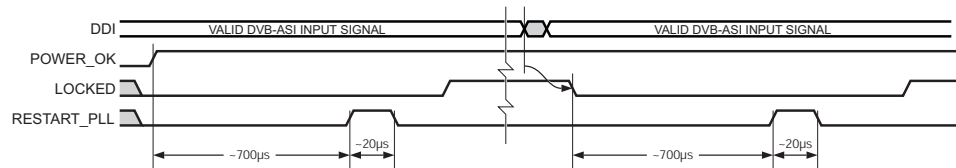

Figure 3-5: GS9090B False Lock Restart Circuit Waveforms of False Lock After Power-up and False Lock After a Signal Switch.

3.7.1 DVB-ASI 8b/10b Decoding

The GS9090B will word align the data to the K28.5 sync characters, and 8b/10b decode and bit-swap the data to achieve bit alignment with the data outputs.

NOTE: DVB-ASI sync words must be immediately followed by an MPEG packet header for word alignment to correctly function.

The extracted 8-bit data will be presented to DOUT [7:0], bypassing all internal SMPTE mode data processing.

3.7.2 Status Signal Outputs

In DVB-ASI mode, the DOUT9 and DOUT8 pins will be configured as DVB-ASI status signals WORDERR and SYNCOUT respectively.

SYNCOUT will be HIGH whenever a K28.5 sync character is present on the output. WORDERR will be HIGH whenever the device has detected an illegal 8b/10b code word or there is a running disparity error.

3.8 Data-Through Functionality

The GS9090B may be configured to operate as a simple serial-to-parallel converter. In this mode, the data is output to the parallel output without performing any decoding, descrambling, or word-alignment.

Data-Through functionality is enabled when the $\overline{\text{AUTO/MAN}}$, $\overline{\text{SMPTE_BYPASS}}$, and $\overline{\text{DVB_ASI}}$ input pins are set to logic LOW. Under these conditions, the GS9090B allows 270Mb/s input data not conforming to SMPTE or DVB-ASI streams to be reclocked and deserialized. If the device is in Data-Through mode, and the reclocker locks to the data stream, the LOCKED pin will be representative of the serial digital input data frequency.

3.9 Additional Processing Features

The GS9090B contains additional processing features that are available in SMPTE mode only (see [Section 3.6](#)).

3.9.1 FIFO Load Pulse

To aid in the implementation of auto-phasing and line synchronization functions, the GS9090B will generate a FIFO load pulse to reset line-based FIFO storage. This $\overline{\text{FIFO_LD}}$ signal is available for output on one of the multi-function output port pins, if so programmed (see [Section 3.12](#)).

The $\overline{\text{FIFO_LD}}$ pulse is an active LOW signal which will assert LOW for one PCLK period, generating a FIFO write reset signal. This signal is co-timed to the SAV XYZ code word present on the output data bus. This ensures that the next PCLK cycle will correspond with the first active sample of the video line.

NOTE: When the internal FIFO of the GS9090B is set to operate in video mode, the $\overline{\text{FIFO_LD}}$ pulse can be used to drive the $\overline{\text{RD_RESET}}$ input to the device (see [Section 3.10.1](#)).

[Figure 3-6](#) shows the default timing relationship between the $\overline{\text{FIFO_LD}}$ signal and the output video data.

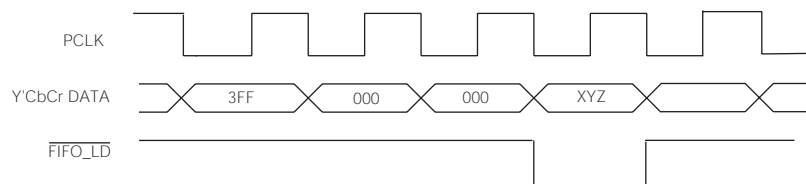

Figure 3-6: $\overline{\text{FIFO_LD}}$ Pulse Timing

3.9.1.1 Programmable FIFO Load Position

The position of the $\overline{\text{FIFO_LD}}$ pulse can be moved in PCLK increments from its default position at the SAV XYZ code word to a maximum of one full line from the default position. The offset number of PCLK's must be programmed in the $\text{FIFO_LD_POSITION}[12:0]$ internal register (address 28h), via the host interface.

The $\text{FIFO_LD_POSITION}[12:0]$ register is designed to accommodate the longest SD line length. If a value greater than the maximum line length at the operating SD standard is programmed in this register, the $\overline{\text{FIFO_LD}}$ pulse will not be generated.

After a device reset, the $\text{FIFO_LD_POSITION}[12:0]$ register is set to zero and the $\overline{\text{FIFO_LD}}$ pulse will assume the default timing.

3.9.2 Ancillary Data Detection and Indication

The GS9090B will detect all types of ancillary data in either the vertical or horizontal data spaces. The ANC status signal is provided to indicate the position of ancillary data in the output data stream. This signal is available for output on the multi-function output port pins (see [Section 3.12](#)).

The ANC status signal is synchronous with PCLK and can be used as a clock enable to external logic, or as a write enable to an external FIFO or other memory device. The ANC signal will be asserted HIGH whenever ancillary data is detected in the video data stream (see [Figure 3-7](#)). Both 8-bit and 10-bit ancillary data preambles will be detected by the GS9090B.

NOTE: When the internal FIFO is configured for video mode, the ANC signal will be timed to the data output from the FIFO (see [Section 3.10.1](#)).

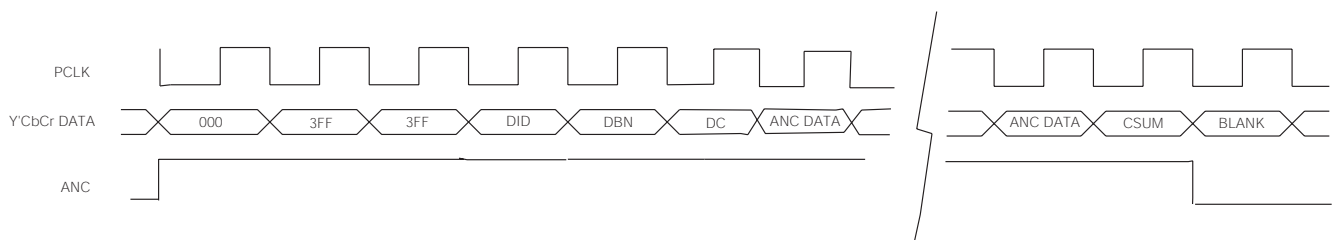

Figure 3-7: ANC Status Signal

3.9.2.1 Programmable Ancillary Data Detection

The GS9090B will detect all types of ancillary data by default. In addition, up to five different ancillary data types can be programmed for detection. This is accomplished by programming the ANC_TYPE registers with the DID and/or SDID values, via the host interface, for each data type to be detected (see [Table 3-4](#)).

The GS9090B will compare the received DID and/or SDID with the programmed values and assert ANC only if an exact match is found.

If the DID or SDID values are set to zero in the ANC_TYPE register, a comparison or match for that codeword will not be made. For example, if the DID is programmed but the SDID is set to zero, the device will detect all ancillary data types matching the DID value, regardless of the SDID. If both DID and SDID values are non-zero, then the received ancillary data type must match both the DID and SDID cases before the device will assert ANC HIGH.

In the case where all five DID and SDID values are set to zero, the GS9090B will detect all ancillary data types. This is the default setting after a device reset.

If greater than one, but less than five, DID and/or SDID values have been programmed, then only those matching ancillary data types will be detected and indicated.

NOTE: See SMPTE 291M for a definition of ancillary data terms.

Table 3-4: Host Interface Description for Programmable Ancillary Data Type registers

Register Name	Bit	Name	Description	R/W	Default
ANC_TYPE 1 Address: 0Ah	15-8	ANC_TYPE1[15:8]	Used to program the DID for ancillary data detection at ANC output	R/W	0
	7-0	ANC_TYPE1[7:0]	Used to program the SDID for ancillary data detection at ANC output. Should be set to zero if no SDID is present in the ancillary data packet to be detected.	R/W	0
ANC_TYPE 2 Address: 0Bh	15-8	ANC_TYPE2[15:8]	Used to program the DID for ancillary data detection at ANC output	R/W	0
	7-0	ANC_TYPE2[7:0]	Used to program the SDID for ancillary data detection at ANC output. Should be set to zero if no SDID is present in the ancillary data packet to be detected.	R/W	0
ANC_TYPE 3 Address: 0Ch	15-8	ANC_TYPE3[15:8]	Used to program the DID for ancillary data detection at ANC output	R/W	0
	7-0	ANC_TYPE3[7:0]	Used to program the SDID for ancillary data detection at ANC output. Should be set to zero if no SDID is present in the ancillary data packet to be detected.	R/W	0
ANC_TYPE 4 Address: 0Dh	15-8	ANC_TYPE4[15:8]	Used to program the DID for ancillary data detection at ANC output	R/W	0
	7-0	ANC_TYPE4[7:0]	Used to program the SDID for ancillary data detection at ANC output. Should be set to zero if no SDID is present in the ancillary data packet to be detected.	R/W	0
ANC_TYPE 5 Address: 0Eh	15-8	ANC_TYPE5[15:8]	Used to program the DID for ancillary data detection at ANC output	R/W	0
	7-0	ANC_TYPE5[7:0]	Used to program the SDID for ancillary data detection at ANC output. Should be set to zero if no SDID is present in the ancillary data packet to be detected.	R/W	0

3.9.3 EDH Packet Detection

The GS9090B will determine if EDH packets are present in the incoming video data and assert the EDH_DETECT output status signal appropriately.

EDH_DETECT will be set HIGH when EDH packets have been detected and will remain HIGH until EDH packets are no longer present. The signal will be set LOW at the end of the vertical blanking (falling edge of V) if an EDH packet has not been received and detected during vertical blanking.

EDH_DETECT can be programmed to be available for output on the multi-function output port pins (see [Section 3.12](#)). The EDH_DETECT bit is also available in the DATA_FORMAT register at address 04h (see [Table 3-7](#)).

3.9.4 EDH Flag Detection

As described in [Section 3.9.3](#), the GS9090B can detect EDH packets in the received data stream. The EDH flags for ancillary data, active picture, and full field areas are extracted from the detected EDH packets and placed in the EDH_FLAG_IN register at address 02h ([Table 3-5](#)).

When the EDH_FLAG_UPDATE bit in the DATA_FORMAT register 04h ([Table 3-7](#)) is set HIGH, the GS9090B will update the ancillary data, full field, and active picture EDH flags according to SMPTE RP165. The updated EDH flags are available in the EDH_FLAG_OUT register at address 03h ([Table 3-6](#)). The EDH packet output from the device will contain the updated flags.

One set of flags is provided for both fields 1 and 2. Field 1 flag data will be overwritten by field 2 flag data.

When EDH packets are not detected, the UES flags in the EDH_FLAG_OUT register will be set HIGH to signify that the received signal does not support Error Detection and Handling. In addition, the EDH_DETECT bit will be set LOW. These flags are set regardless of the setting of the EDH_FLAG_UPDATE bit.

EDH_FLAG_OUT and EDH_FLAG_UPDATE may be read by the host interface at any time during the received frame except on the lines defined in SMPTE RP165, where these flags are updated.

The GS9090B will indicate the CRC validity for both active picture and full field CRCs. The AP_CRC_V bit in the DATA_FORMAT register indicates the active picture CRC validity, and the FF_CRC_V bit indicates the full field CRC validity (see [Table 3-7](#)). When EDH_DETECT = LOW, these bits will be cleared.

The EDH_FLAG_OUT and EDH_FLAG_UPDATE register values remain set until overwritten by the decoded flags in the next received EDH packet in the following field. When an EDH packet is not detected during vertical blanking, the flag registers will be cleared at the end of the vertical blanking period.

Table 3-5: Host Interface Description for EDH Flag Registers

Register Name	Bit	Name	Description	R/W	Default
EDH_FLAG_IN Address: 02h	15	–	Not Used	–	–
	14	ANC-UES_IN	Ancillary Unknown Error Status Flag	R	0
	13	ANC-IDA_IN	Ancillary Internal device error Detected Already Flag.	R	0
	12	ANC-IDH_IN	Ancillary Internal device error Detected Here Flag.	R	0
	11	ANC-EDA_IN	Ancillary Error Detected Already Flag.	R	0
	10	ANC-EDH_IN	Ancillary Error Detected Here Flag.	R	0
	9	FF-UES_IN	Full Field Unknown Error Status Flag.	R	0
	8	FF-IDA_IN	Full Field Internal device error Detected Already Flag.	R	0
	7	FF-IDH_IN	Full Field Internal device error Detected Here Flag.	R	0

Table 3-5: Host Interface Description for EDH Flag Registers (Continued)

Register Name	Bit	Name	Description	R/W	Default
	6	FF-EDA_IN	Full Field Error Detected Already Flag.	R	0
	5	FF-EDH_IN	Full Field Error Detected Here Flag.	R	0
	4	AP-UES_IN	Active Picture Unknown Error Status Flag.	R	0
	3	AP-IDA_IN	Active Picture Internal device error Detected Already Flag.	R	0
	2	AP-IDH_IN	Active Picture Internal device error Detected Here Flag	R	0
	1	AP-EDA_IN	Active Picture Error Detected Already Flag.	R	0
	0	AP-EDH_IN	Active Picture Error Detected Here Flag.	R	0

Table 3-6: Host Interface Description for EDH Flag Registers

Register Name	Bit	Name	Description	R/W	Default
EDH_FLAG_OUT Address: 03h	15	–	Not Used	–	–
	14	ANC-UES	Ancillary Unknown Error Status Flag	R	0
	13	ANC-IDA	Ancillary Internal device error Detected Already Flag.	R	0
	12	ANC-IDH	Ancillary Internal device error Detected Here Flag.	R	0
	11	ANC-EDA	Ancillary Error Detected Already Flag.	R	0
	10	ANC-EDH	Ancillary Error Detected Here Flag.	R	0
	9	FF-UES	Full Field Unknown Error Status Flag.	R	0
	8	FF-IDA	Full Field Internal device error Detected Already Flag.	R	0
	7	FF-IDH	Full Field Internal device error Detected Here Flag.	R	0
	6	FF-EDA	Full Field Error Detected Already Flag.	R	0
	5	FF-EDH	Full Field Error Detected Here Flag.	R	0
	4	AP-UES	Active Picture Unknown Error Status Flag.	R	0
	3	AP-IDA	Active Picture Internal device error Detected Already Flag.	R	0
	2	AP-IDH	Active Picture Internal device error Detected Here Flag	R	0
	1	AP-EDA	Active Picture Error Detected Already Flag.	R	0
	0	AP-EDH	Active Picture Error Detected Here Flag.	R	0

Table 3-7: Host Interface Description for Data Format Register

Register Name	Bit	Name	Description	R/W	Default
DATA_FORMAT Address: 04h	15-12	–	Not Used	–	–
	11	EDH_FLAG_UPDATE	When set HIGH, the device will update the ancillary data, full field, and active picture EDH flags according to SMPTE RP165.	R/W	0
	10	AP_CRC_V	Active Picture CRC Valid bit.	R	0
	9	FF_CRC_V	Full Field CRC Valid bit.	R	0
	8	EDH_DETECT	Set HIGH by the device when EDH packets are detected in the incoming video data.	R	0
	7	VERSION_352M	Indicates whether decoded SMPTE 352M packet is version 0 or version 1. See Section 3.9.5 .	R	0
	6-5	–	Not Used	–	–
	4	STD_LOCK	Standard Lock bit. This bit will be set HIGH when the flywheel has achieved full synchronization to the received video standard. See Section 3.9.6 .	R	0
	3-0	DATA_FORMAT[3:0]	Displays the data format being carried on the serial digital interface. See Section 3.9.6.1 .	R	0

3.9.5 SMPTE 352M Payload Identifier

The GS9090B can receive and detect the presence of the SMPTE 352M payload identifier.

Upon detection of this packet, the device will extract the four words contained in the packet to the VIDEO_FORMAT_OUT_A and VIDEO_FORMAT_OUT_B registers at addresses 10h and 0fh ([Table 3-8](#)). The device will also indicate the version of the payload packet in bit 7 of the DATA_FORMAT register ([Table 3-7](#)). When bit 7 is set HIGH the received SMPTE 352M packet is version 1, otherwise it is version 0.

The VIDEO_FORMAT registers will only be updated if the received checksum is the same as the locally calculated checksum.

If the device loses lock to the input data stream (LOCKED = LOW), or if the SMPTE_BYPASS pin is asserted LOW, the VIDEO_FORMAT_OUT_A and VIDEO_FORMAT_OUT_B registers will be cleared to zero, indicating an undefined format. This is also the default setting after a device reset.

Table 3-8: Host Interface Description for SMPTE 352M Payload Identifier Registers

Register Name	Bit	Name	Description	R/W	Default
VIDEO_FORMAT_OUT_B Address: 10h	15-8	SMPTE 352M Byte 4	Data will be available in this register when Video Payload Identification Packets are detected in the data stream.	R	0
	7-0	SMPTE 352M Byte 3	Data will be available in this register when Video Payload Identification Packets are detected in the data stream.	R	0
VIDEO_FORMAT_OUT_A Address: 0Fh	15-8	SMPTE 352M Byte 2	Data will be available in this register when Video Payload Identification Packets are detected in the data stream.	R	0
	7-0	SMPTE 352M Byte 1	Data will be available in this register when Video Payload Identification Packets are detected in the data stream.	R	0

3.9.6 Automatic Video Standard and Data Format Detection

The GS9090B can detect the input video standard and data format by using the timing parameters extracted from the received TRS ID. Total samples per line, active samples per line, total lines per frame, and active lines per field are all calculated and presented to the host interface via the RASTER_STRUCTURE registers (Table 3-9).

Also associated with the RASTER_STRUCTURE registers is the STD_LOCK status bit. The GS9090B will set STD_LOCK HIGH when the flywheel has achieved full synchronization to the received video standard. STD_LOCK is stored in the DATA_FORMAT register (Table 3-7).

The four RASTER_STRUCTURE registers, as well as the STD_LOCK status bit will default to zero after a device reset, or if the device loses lock to the input data stream (LOCKED = LOW).

Table 3-9: Host Interface Description for Raster Structure Registers

Register Name	Bit	Name	Description	R/W	Default
RASTER_STRUCTURE1 Address: 11h	15-11	–	Not Used	–	–
	10-0	RASTER_STRUCTURE1[10:0]	Total Lines Per Frame	R	0
RASTER_STRUCTURE2 Address: 12h	15-13	–	Not Used	–	–
	12-0	RASTER_STRUCTURE2[12:0]	Total Words Per Line	R	0
RASTER_STRUCTURE3 Address: 13h	15-13	–	Not Used	–	–
	12-0	RASTER_STRUCTURE3[12:0]	Words Per Active Line	R	0
RASTER_STRUCTURE4 Address: 14h	15-11	–	Not Used	–	–
	10-0	RASTER_STRUCTURE4[10:0]	Active Lines Per Field	R	0

3.9.6.1 Data Format Indication

The GS9090B can extract the data format being carried on the serial digital interface (i.e. SDTI, SDI, or DVB-ASI). This information is represented by bits 0 to 3 of the DATA_FORMAT register (Table 3-7).

DATA_FORMAT[3:0] register codes are shown in Table 3-10.

The DATA_FORMAT[3:0] register defaults to Fh (undefined) after a system reset. The register will also be set to its default value if the device is not locked (LOCKED = LOW), or if both SMPTE_BYPASS and DVB_ASI pins are LOW.

Table 3-10: Data Format Register Codes

Data Format[3:0]	Data Format	Applicable Standards
0h	SDTI DVCPRO - No ECC	SMPTE 321M
1h	SDTI DVCPRO - ECC	SMPTE 321M
2h	SDTI DVCAM	SMPTE 322M
3h	SDTI CP	SMPTE 326M
4h	Other SDTI fixed block size	–
5h	Other SDTI variable block size	–
6h	SDI	–
7h	DVB-ASI	–
8h ~ Eh	Reserved	–
Fh	Unknown data format	–

3.9.7 Error Detection and Indication

The GS9090B contains a number of error detection functions to enhance operation of the device when operating in SMPTE mode. These functions, except lock error detection, will not be available in DVB-ASI mode (Section 3.7) or Data-Through mode (Section 3.8).

The ERROR_STATUS register is at address 01h (Table 3-11). All bits, except the LOCK_ERR bit, will be cleared at the start of each video field or when read by the host interface, whichever condition occurs first.

All bits, with the exception of the LOCK_ERR, will also be cleared if a change in the video standard is detected, if the device loses lock to the input data stream (LOCKED = LOW), or if the SMPTE_BYPASS pin is asserted LOW.

The ERROR_STATUS register, including the LOCK_ERR bit, will be set LOW during a system reset (RESET = LOW).

The ERROR_MASK register (Table 3-12) is available to individually mask each error type in the ERROR_STATUS register. Each error type may be individually masked by setting its corresponding bit HIGH. The bits of the ERROR_MASK register will default to '0' after a device reset, thus allowing all error types to be detected.

The $\overline{\text{DATA_ERROR}}$ signal pin indicates the status of the ERROR_STATUS register. This output pin is an inverted logical OR of each error status flag stored in the ERROR_STATUS register. $\overline{\text{DATA_ERROR}}$ will be set LOW by the device when an error condition that has not been masked is detected.

Table 3-11: Host Interface Description for Error Status Register

Register Name	Bit	Name	Description	R/W	Default
ERROR_STATUS Address: 01h	15-7	–	Not Used	–	–
	6	VD_STD_ERR	Video Standard Error Flag. Set HIGH when a mismatch between the received SMPTE 352M packets (version 1 or version 0) and the calculated video standard occurs.	R	0
	5	FF_CRC_ERR	Full Field CRC Error Flag. Set HIGH when a Full Field (FF) CRC mismatch has been detected in Field 1 or 2	R	0
	4	AP_CRC_ERR	Active Picture CRC Error Flag. Set HIGH when an Active Picture (AP) CRC mismatch has been detected in Field 1 or 2.	R	0
	3	LOCK_ERR	Lock Error Flag. Set HIGH whenever the LOCKED pin is LOW (indicating the device is not correctly locked).	R	0
	2	CS_ERR	Checksum Error Flag. Set HIGH when ancillary data packet checksum error has been detected.	R	0
	1	SAV_ERR	Start of Active Video Error Flag. Set HIGH when TRS errors are detected in either 8-bit or 10-bit TRS words.	R	0
	0	EAV_ERR	End of Active Video Error Flag. Set HIGH when TRS errors are detected in either 8-bit or 10-bit TRS words.	R	0

Table 3-12: Host Interface Description for Error Mask Register

Register Name	Bit	Name	Description	R/W	Default
ERROR_MASK Address: 25h	15-7	–	Not Used	–	–
	6	VD_STD_ERR_MASK	Video Standard Error Flag Mask bit.	R/W	0
	5	FF_CRC_ERR_MASK	Full Field CRC Error Flag Mask bit.	R/W	0
	4	AP_CRC_ERR_MASK	Active Picture CRC Error Flag Mask bit	R/W	0
	3	LOCK_ERR_MASK	Lock Error Flag Mask bit.	R/W	0
	2	CS_ERR_MASK	Checksum Error Flag Mask bit.	R/W	0
	1	SAV_ERR_MASK	Start of Active Video Error Flag Mask bit.	R/W	0
	0	EAV_ERR_MASK	End of Active Video Error Flag Mask bit.	R/W	0

3.9.7.1 Video Standard Error Detection

If a mismatch between the decoded SMPTE 352M packets and the calculated video standard occurs, the GS9090B will indicate a video standard error by setting the VD_STD_ERR bit of the ERROR_STATUS register HIGH. The device will detect errors in both version 1 and version 0 352M packets.

3.9.7.2 EDH CRC Error Detection

The GS9090B calculates the Full Field (FF) and Active Picture (AP) CRC words according to SMPTE RP165 in support of Error Detection and Handling packets in SD signals.

These calculated CRC values are compared with the received CRC values. If a mismatch is detected, the error is flagged in the AP_CRC_ERR and/or FF_CRC_ERR bits of the ERROR_STATUS register. These two flags are shared between fields 1 and 2.

The AP_CRC_ERR bit will be set HIGH when an active picture CRC value mismatch has been detected in field 1 or 2. The FF_CRC_ERR bit will be set HIGH when a full field CRC value mismatch has been detected in field 1 or 2.

EDH CRC errors will only be indicated when the device has correctly received EDH packets.

SMPTE RP165 specifies the calculation ranges and scope of EDH data for standard 525 and 625 component digital interfaces. The GS9090B will utilize these standard ranges by default.

If the received video format does not correspond to 525 or 625 digital component video standards as determined by the flywheel pixel and line counters, the ranges will be based on the line and pixel ranges programmed by the host interface. In the absence of user-programmed calculation ranges, the ranges will be determined from the received TRS timing information.

The registers available to the host interface for programming EDH calculation ranges include active picture and full field line/pixel start and end positions for both fields (Table 3-13). These registers default to '0' after a device reset.

If any or all of these register values are zero, then the EDH CRC calculation ranges will be determined from the flywheel generated timing. The first active and full field pixel will always be the first pixel after the SAV TRS code word. The last active and full field pixel will always be the last pixel before the start of the EAV TRS code words.

Table 3-13: Host Interface Description for EDH Calculation Range Registers

Register Name	Bit	Name	Description	R/W	Default
AP_LINE_START_F0 Address: 15h	15-11	–	Not Used	–	–
	10-0	AP_LINE_START_F0[10:0]	Field 0 Active Picture start line data used to set EDH calculation range outside of SMPTE RP 165 values.	R/W	0
AP_LINE_END_F0 Address: 16h	15-11	–	Not Used	–	–
	10-0	AP_LINE_END_F0[10:0]	Field 0 Active Picture end line data used to set EDH calculation range outside of SMPTE RP 165 values.	R/W	0
AP_LINE_START_F1 Address: 17h	15-11	–	Not Used	–	–
	10-0	AP_LINE_START_F1[10:0]	Field 1 Active Picture start line data used to set EDH calculation range outside of SMPTE RP 165 values.	R/W	0
AP_LINE_END_F1 Address: 18h	15-11	–	Not Used	–	–
	10-0	AP_LINE_END_F1[10:0]	Field 1 Active Picture end line data used to set EDH calculation range outside of SMPTE RP 165 values.	R/W	0
FF_LINE_START_F0 Address: 19h	15-11	–	Not Used	–	–
	10-0	FF_LINE_START_F0[10:0]	Field 0 Full Field start line data used to set EDH calculation range outside of SMPTE RP 165 values.	R/W	0
FF_LINE_END_F0 Address: 1Ah	15-11	–	Not Used	–	–
	10-0	FF_LINE_END_F0[10:0]	Field 0 Full Field end line data used to set EDH calculation range outside of SMPTE RP 165 values.	R/W	0
FF_LINE_START_F1 Address: 1Bh	15-11	–	Not Used	–	–
	10-0	FF_LINE_START_F1[10:0]	Field 1 Full Field start line data used to set EDH calculation range outside of SMPTE RP 165 values.	R/W	0
FF_LINE_END_F1 Address: 1Ch	15-11	–	Not Used	–	–
	10-0	FF_LINE_END_F1[10:0]	Field 1 Full Field end line data used to set EDH calculation range outside of SMPTE RP 165 values.	R/W	0

Table 3-13: Host Interface Description for EDH Calculation Range Registers (Continued)

Register Name	Bit	Name	Description	R/W	Default
AP_PIXEL_START_F0 Address: 1Dh	15-13	–	Not Used	–	–
	12-0	AP_PIXEL_START_F0[12:0]	Field 0 Active Picture start pixel data used to set EDH calculation range outside of SMPTE RP 165 values.	R/W	0
AP_PIXEL_END_F0 Address: 1Eh	15-13	–	Not Used	–	–
	12-0	AP_PIXEL_END_F0[12:0]	Field 0 Active Picture end pixel data used to set EDH calculation range outside of SMPTE RP 165 values.	R/W	0
AP_PIXEL_START_F1 Address: 1Fh	15-13	–	Not Used	–	–
	12-0	AP_PIXEL_START_F1[12:0]	Field 1 Active Picture start pixel data used to set EDH calculation range outside of SMPTE RP 165 values.	R/W	0
AP_PIXEL_END_F1 Address: 20h	15-13	–	Not Used	–	–
	12-0	AP_PIXEL_END_F1[12:0]	Field 1 Active Picture end pixel data used to set EDH calculation range outside of SMPTE RP 165 values.	R/W	0
FF_PIXEL_START_F0 Address: 21h	15-13	–	Not Used	–	–
	12-0	FF_PIXEL_START_F0[12:0]	Field 0 Full Field start pixel data used to set EDH calculation range outside of SMPTE RP 165 values.	R/W	0
FF_PIXEL_END_F0 Address: 22h	15-13	–	Not Used	–	–
	12-0	FF_PIXEL_END_F0[12:0]	Field 0 Full Field end pixel data used to set EDH calculation range outside of SMPTE RP 165 values.	R/W	0
FF_PIXEL_START_F1 Address: 23h	15-13	–	Not Used	–	–
	12-0	FF_PIXEL_START_F1[12:0]	Field 1 Full Field start pixel data used to set EDH calculation range outside of SMPTE RP 165 values.	R/W	0
FF_PIXEL_END_F1 Address: 24h	15-13	–	Not Used	–	–
	12-0	FF_PIXEL_END_F1[12:0]	Field 1 Full Field end pixel data used to set EDH calculation range outside of SMPTE RP 165 values.	R/W	0

3.9.7.3 Lock Error Detection

The LOCKED pin of the GS9090B asserts HIGH when the device has correctly locked to the received data stream (see [Section 3.5.1](#)).

The GS9090B will also indicate lock error to the host interface when LOCKED = LOW by setting the LOCK_ERR bit in the ERROR_STATUS register HIGH ([Table 3-11](#)).

3.9.7.4 Ancillary Data Checksum Error Detection

The GS9090B will calculate checksums for all received ancillary data types and compare the calculated values to the received checksum words. If a mismatch is detected, the CS_ERR bit of the ERROR_STATUS register will be set HIGH ([Table 3-11](#)).

Although the GS9090B will calculate and compare checksum values for all ancillary data types by default, the host interface may be programmed to check only certain types of ancillary data checksums, as described in [Section 3.9.2.1](#).

3.9.7.5 TRS Error Detection

TRS error flags are generated by the GS9090B when the received TRS H timing does not correspond to the internal flywheel timing, or when the received TRS Hamming codes are incorrect.

These errors are flagged via the SAV_ERR and/or EAV_ERR bits of the ERROR_STATUS register ([Table 3-11](#)). Both 8-bit and 10-bit SAV and EAV errors are handled by the GS9090B.

NOTE: H timing based TRS errors will only be detected if the FW_EN pin is set HIGH. F & V timing errors are not detected or corrected.

3.9.8 Additional Processing Functions

The GS9090B contains an additional processing block which is available in SMPTE mode only. The IOPROC_EN pin must be set HIGH to enable these functions. These functions, which are all enabled by default, may be enabled or disabled individually by setting bits 0 to 3 in the IOPROC_DISABLE register ([Table 3-14](#)).

NOTE: After a device reset, these functions will revert to their default values.

Table 3-14: Host Interface Description for Internal Processing Disable Register

Register Name	Bit	Name	Description	R/W	Default
IOPROC_DISABLE Address: 00h	15-10	–	Not Used	–	–
	9	ANC_PKT_EXT	Ancillary Packet Extraction. When the FIFO is configured for Ancillary Data Extraction mode, this bit must be set HIGH to begin extraction. NOTE: Setting ANC_PKT_EXT LOW will not automatically disable ancillary data extraction (see Section 3.10.3.1).	R/W	0
	8-7	FIFO_MODE[1:0]	FIFO Mode: These bits control which mode the internal FIFO is operating in (see Table 3-15)	R/W	0
	6	H_CONFIG	Horizontal sync timing output configuration. Set LOW for active line blanking timing. Set HIGH for H blanking based on the H bit setting of the TRS word. See Figure 3-3 in Section 3.6.4 .	R/W	0
	5-4		Not Used.		
	3	ILLEGAL_REMAP	Illegal Code re-mapping. Correction of illegal code words within the active picture. Set HIGH to disable. The IOPROC_EN pin must be set HIGH.	R/W	0
	2	EDH_CRC_INS	Error Detection & Handling (EDH) Cyclical Redundancy Check (CRC) error correction insertion. Set HIGH to disable. The IOPROC_EN pin must be set HIGH.	R/W	0
	1	ANC_CSUM_INS	Ancillary Data Checksum insertion. Set HIGH to disable. The IOPROC_EN pin must be set HIGH.	R/W	0
	0	TRS_INS	Timing Reference Signal Insertion. The device will correct TRS based errors when set LOW (see Section 3.9.8.4). The IOPROC_EN pin must also be HIGH. Set this bit HIGH to disable.	R/W	0

3.9.8.1 Illegal Code Remapping

If the ILLEGAL_REMAP bit of the IOPROC_DISABLE register is set LOW, the GS9090B will remap all codes within the active picture between the values 3FCh and 3FFh to 3FBh. All codes within the active picture area between the values 00h and 03h will be re-mapped to 04h. In addition, 8-bit TRS and ancillary data preambles will be remapped to 10-bit values.

3.9.8.2 EDH CRC Error Correction

If the EDH_CRC_INS bit of the IOPROC_DISABLE register is set LOW, the GS9090B will calculate and overwrite the active picture and full field CRC words into the EDH data packets received by the device.

Additionally, when EDH_CRC_INS is LOW, the device will set the active picture and full field CRC 'V' bits HIGH in the EDH packet (see [Section 3.9.4](#)). The AP_CRC_V and FF_CRC_V register bits will only report the received EDH validity flags.

EDH CRC calculation ranges are described in [Section 3.9.7.2](#).

NOTE: Although the GS9090B will modify and insert EDH CRC words and EDH packet checksums, the device will only update EDH error flags when the EDH_FLAG_UPDATE bit is set HIGH (see [Section 3.9.4](#)).

3.9.8.3 Ancillary Data Checksum Error Correction

If the ANC_CSUM_INS bit of the IOPROC_DISABLE register is set LOW, ancillary checksum error correction and insertion is enabled, and the GS9090B will calculate and overwrite ancillary data checksums for all ancillary data words by default. If the Ancillary Data type has been specified in the ANC_TYPE registers of the host interface (see [Section 3.9.2.1](#)), only the checksums for the ancillary data programmed will be updated.

3.9.8.4 TRS Error Correction

If the TRS_INS bit of the IOPROC_DISABLE register is set LOW, TRS error correction and insertion is enabled. In this mode, the GS9090B will calculate and overwrite 10-bit TRS code words as required.

TRS code word generation will be performed using the timing parameters generated by the flywheel to provide an element of noise immunity, and will only take place if the flywheel is enabled (FW_EN = HIGH).

NOTE: Only H timing based errors will be corrected (see [Section 3.9.7.5](#)).

3.10 Internal FIFO Operation

The GS9090B contains an internal video line-based FIFO, which can be programmed to work in any of the following modes:

1. Video Mode,
2. DVB-ASI Mode,
3. Ancillary Data Extraction Mode, or
4. Bypass Mode

The FIFO can be configured to one of the four modes by using the host interface to set the FIFO_MODE[1:0] bits of the IOPROC_DISABLE register (see [Table 3-14](#) in [Section 3.9.8](#)). The setting of these bits is shown in [Table 3-15](#). To enable the FIFO, the FIFO_EN pin must be set HIGH. Additionally, if the FIFO is configured for video mode or ancillary data extraction mode, the IOPROC_EN pin must be set HIGH.

The FIFO is fully asynchronous, allowing simultaneous read and write access. It has a depth of 2048 words, which will accommodate 1 full line of SD video for both 525 and 625 standards. The FIFO is 15 bits wide: 10 bits for video data and 5 bits for other signals, such as H, V, F, EDH_DETECT, and ANC.

Table 3-15: FIFO Configuration Bit Settings

FIFO Mode	FIFO_MODE[1:0] Register Setting	FIFO_EN Pin Setting	IOPROC_EN Pin Setting
Video Mode	00b	HIGH	HIGH
DVB-ASI Mode	01b	HIGH	X
Ancillary Data Extraction Mode	10b	HIGH	HIGH
Bypass Mode	11b	X	X

NOTE: 'X' signifies 'don't care'. The pin is ignored and may be set HIGH or LOW.

3.10.1 Video Mode

The internal FIFO is in video mode when the FIFO_EN and IOPROC_EN pins are set HIGH, and the FIFO_MODE[1:0] bits in the IOPROC_DISABLE register are configured to 00b. By default, the FIFO_MODE[1:0] bits are set to 00b by the device whenever the SMPTE_BYPASS pin is set HIGH and the DVB_ASI pin is set LOW (i.e. the device is in SMPTE mode); however, the FIFO_MODE[1:0] bits may be programmed as required.

[Figure 3-8](#) shows the input and output signals of the FIFO when it is configured for video mode.

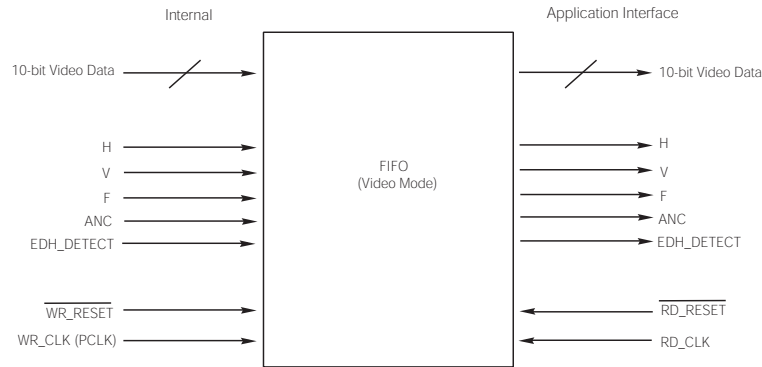

Figure 3-8: FIFO in Video Mode

When operating in video mode, the GS9090B will write data sequentially into the FIFO, starting with the first active pixel in location zero of the memory. In this mode, it is possible to use the FIFO for clock phase interchange and data alignment / delay. The extracted H, V, and F information will also be written into the FIFO. The H, V, and F outputs will be timed to the video data read from the FIFO. (see [Section 3.6.4](#)).

The device will ensure write-side synchronization is maintained, according to the extracted PCLK and flywheel timing information.

Full read-control of the FIFO is made available such that data will be clocked out of the FIFO on the rising edge of the externally provided RD_CLK signal. When there is a HIGH-to-LOW transition at the RD_RESET pin, the first pixel presented to the video data bus will be the first 000 of the SAV (see [Figure 3-9](#)). The FIFO_LD pulse may be used to control the RD_RESET pin.

NOTE: The RD_RESET pulse should not be held LOW for more than one RD_CLK cycle.

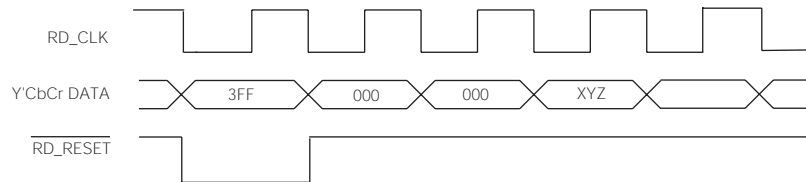

Figure 3-9: RD_RESET Pulse Timing

In video mode, the ANC output signal will be timed to the data output from the FIFO (see [Section 3.9.2](#) for more detail).

3.10.2 DVB-ASI Mode

The internal FIFO is in DVB-ASI mode when the FIFO_EN pin is set HIGH, and the FIFO_MODE[1:0] bits in the IOPROC_DISABLE register are configured to 01b. By default, the FIFO_MODE[1:0] bits are set to 01b by the device whenever the

DVB_ASI pin is set HIGH (i.e. the device is in DVB-ASI mode); however, the FIFO_MODE[1:0] bits may be programmed as required.

Figure 3-10 shows the input and output signals of the FIFO when it is configured for DVB-ASI Mode.

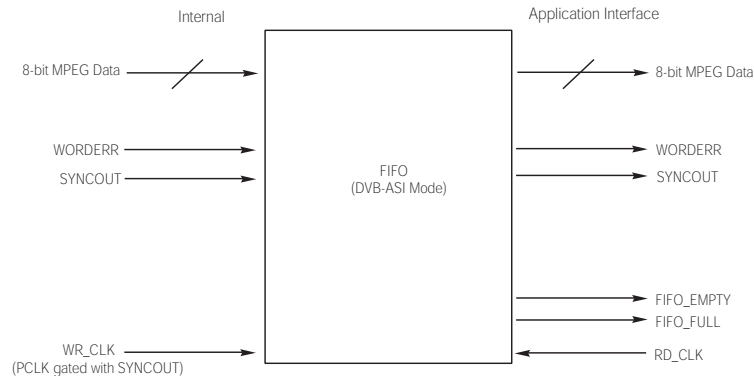

Figure 3-10: FIFO in DVB-ASI Mode

When operating in DVB-ASI mode, the GS9090B's FIFO can be used for clock rate interchange operation. The extracted 8-bit MPEG packets will be written into the FIFO at 27MHz based on the SYNCOUT signal from the internal DVB-ASI decoder block. The SYNCOUT and WORDERR bits are also stored in the FIFO (see Section 3.7.2).

When SYNCOUT goes HIGH, K28.5 stuffing characters have been detected and no data will be written into the FIFO.

Data is read out of the FIFO using the RD_CLK pin. In DVB-ASI mode, the RD_RESET pin is not used.

NOTE: With the internal FIFO enabled in DVB-ASI mode, SYNCOUT will always be LOW since the K28.5 sync characters are not stored in the FIFO.

3.10.2.1 Reading From the FIFO

The FIFO contains internal read and write pointers used to designate which spot in the FIFO the MPEG packet will be read from or written to. These internal pointers control the status flags FIFO_EMPTY and FIFO_FULL, which are available for output on the multi-function output port pins, if so programmed (see Section 3.12).

In the case where the write pointer is originally ahead of the read pointer, the FIFO_EMPTY flag will be set HIGH when both pointers arrive at the same address (see block A in Figure 3-12). This flag can be used to determine when to stop reading from the device.

A write and read pointer offset may be programmed in the FIFO_EMPTY_OFFSET[9:0] register of the host interface. If an offset value is programmed in this register, the FIFO_EMPTY flag will be set HIGH when the read and write pointers of the FIFO are at the same address, and will remain HIGH until

the write pointer reaches the programmed offset. Once the pointer offset has been exceeded, the FIFO_EMPTY flag will go LOW (see block B in Figure 3-12).

In the case where the read pointer is originally ahead of the write pointer, the FIFO_FULL flag will be set HIGH when both pointers arrive at the same address (see block C in Figure 3-12). This flag can be used to determine when to begin reading from the device.

A read and write pointer offset may also be programmed in the FIFO_FULL_OFFSET[9:0] register of the host interface. If an offset value is programmed in this register, the FIFO_FULL flag will be set HIGH when the read and write pointers of the FIFO are at the same address, and will remain set HIGH until the read pointer reaches the programmed offset. Once the pointer offset has been exceeded, the FIFO_FULL flag will be cleared (see block D in Figure 3-12).

Gating the RD_CLK Using the FIFO_EMPTY Flag

Using the asynchronous FIFO_EMPTY flag to gate RD_CLK requires external clock gating circuitry. The recommended circuit for this application is shown in Figure 3-11.

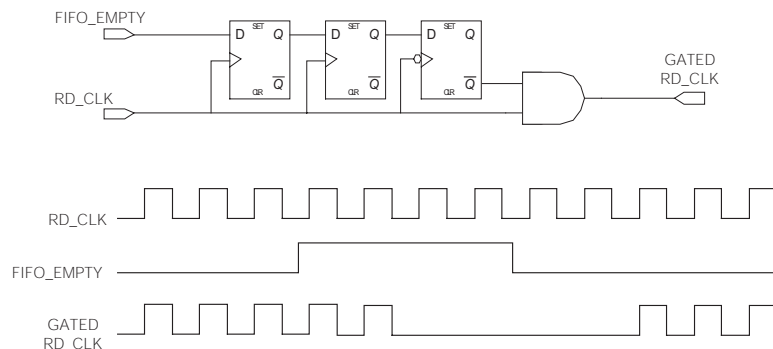

Figure 3-11: Recommended Circuit to Gate RD_CLK Using the FIFO_EMPTY Flag

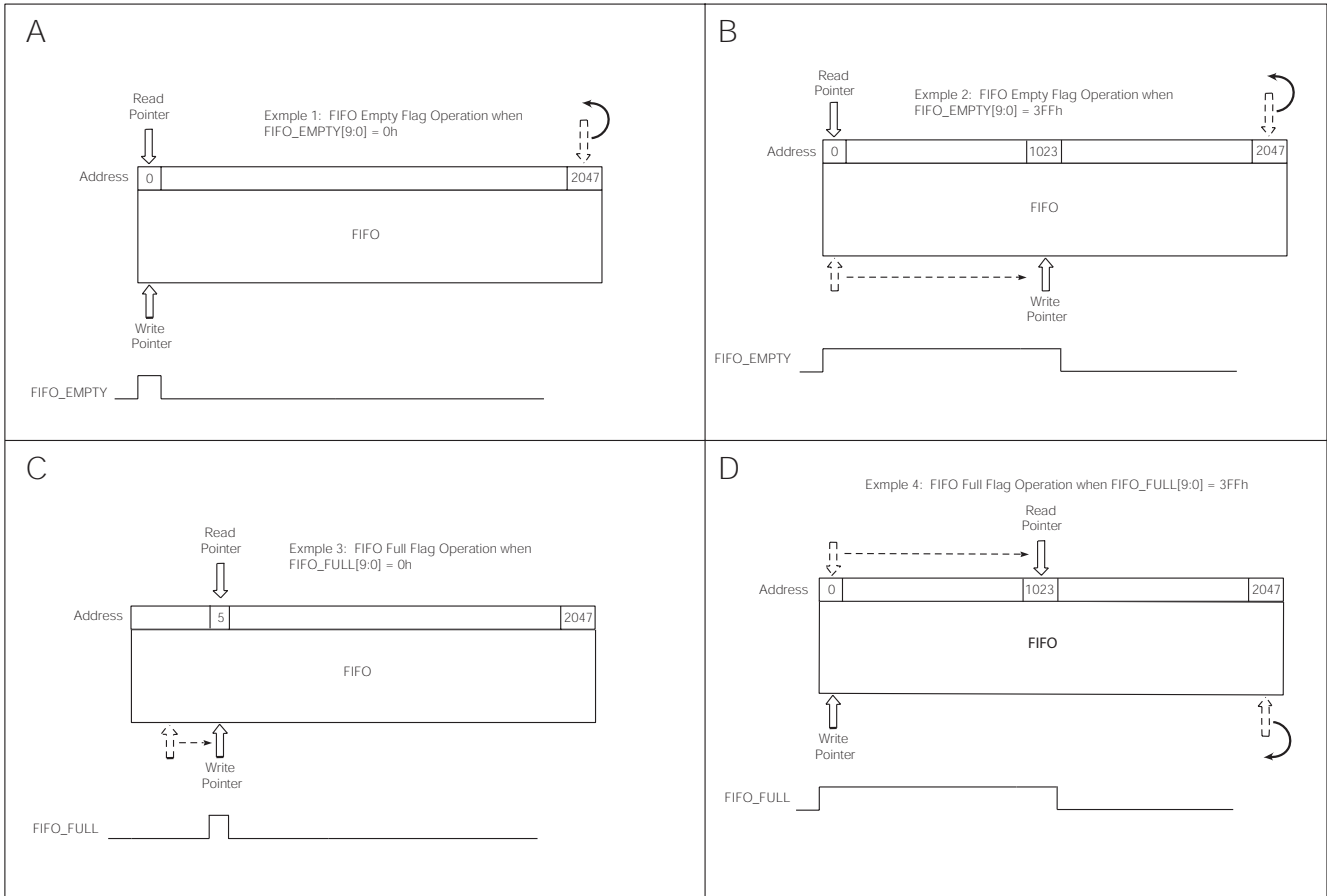

Figure 3-12: Reading From the FIFO in DVB-ASI Mode

3.10.3 Ancillary Data Extraction Mode

The internal FIFO is in ancillary data extraction mode when the FIFO_EN and IOPROC_EN pins are set HIGH, and the FIFO_MODE[1:0] bits in the IOPROC_DISABLE register are configured to 10b.

Once the FIFO enters ancillary data extraction mode, it takes 2200 PCLKs (82us) to initialize the FIFO before ancillary data extraction can begin.

In this mode, the FIFO is divided into two separate blocks of 1024 words each. This allows ancillary data to be written to one side of the FIFO and from the other. Thus, in each half of the FIFO, the GS9090B will write the contents of the packets up to a maximum of 1024 8-bit words.

As described in [Section 3.9.2.1](#), up to five specific types of ancillary data to be extracted can be programmed in the ANC_TYPE registers. If the ANC_TYPE registers are all set to zero, the device will extract all types of ancillary data.

The entire packet, including the ancillary data flag (ADF), data identification (DID), secondary data identification (SDID), data count (DC), and checksum word will be written into the memory. The device will detect ancillary data packet DID's placed anywhere in the video data stream, including the active picture area.

Additionally, the lines from which the packets are to be extracted from can be programmed into the ANC_LINE_A[10:0] and ANC_LINE_B[10:0] registers, allowing ancillary data from a maximum of two lines per frame to be extracted. If only one line number register is programmed (with the other set to zero), ancillary data packets will be extracted from one line per frame only. When both registers are set to zero, the device will extract packets from all lines.

The extracted ancillary data is read through the host interface starting at address 02Ch up to 42Bh inclusive (1024 words). This must be done while there is a valid video signal present at the serial input and the device is locked (LOCKED = HIGH).

3.10.3.1 Ancillary Data Extraction and Reading

To start ancillary data extraction, the ANC_PKT_EXT bit of the IOPROC_DISABLE register must be set HIGH (see [Table 3-14](#) in [Section 3.9.8](#)). Packet extraction will begin in the following frame after this bit has been set HIGH.

NOTE: Ancillary data extraction will not begin until 2200 PCLKs (82us) after the device has entered into ancillary data extraction mode (FIFO_MODE[1:0] = 10b), regardless of the setting of the ANC_PKT_EXT bit.

When the FIFO is configured for ancillary data extraction mode, setting the IOPROC_EN pin LOW will disable packet extraction. If IOPROC_EN is LOW, the setting of the ANC_PKT_EXT host interface bit will be ignored.

Clearing the ANC_PKT_EXT bit will not automatically disable ancillary data extraction. To disable ancillary data extraction, switch the FIFO into bypass mode by setting FIFO_MODE[1:0] = 11b. 2200 PCLK cycles after the device re-enters ancillary data extraction mode, data extraction will commence immediately if ANC_PKT_EXT is still HIGH.

The ANC output flag available on the I/O output pin (see [Section 3.12](#)) can be used to determine the length of the ancillary data extracted and when to begin reading the extracted data from memory. Recall that ANC is HIGH whenever ancillary data has been detected.

In addition, the data count (DC) word, which is located three words after the ancillary data flag (ADF) in the memory, can be read to determine how many valid user data words (UDW) are present in the extracted packet (see SMPTE 291M for more details). The DC value can then be used to preset how many address reads must be performed to obtain only the user data words.

Ancillary data will be written into the first half of the FIFO until it is full or until the ANC_DATA_SWITCH bit is toggled (i.e. a HIGH-to-LOW or LOW-to-HIGH transition). If the ANC_DATA_SWITCH bit is not toggled, extracted data will not be written into memory after the first half of the FIFO is full (see block A in [Figure 3-13](#)).

When the ANC_DATA_SWITCH bit is toggled, new extracted data will be written to the second half starting at address zero (see block B in [Figure 3-13](#)). The data in the first half of the FIFO may still be read.

Once the data in the first half of the FIFO has been read, the ANC_DATA_SWITCH may be toggled again to enable the second half of the FIFO to be read. The first half of the FIFO will be cleared, and the device will continue to write ancillary data to the second half of the FIFO (see block C in [Figure 3-13](#)).

If the ANC_DATA_SWITCH bit is toggled again, new extracted data will be written to the first half starting at address zero (see block D in [Figure 3-13](#)). The data in the second half of the FIFO may still be read.

Toggling ANC_DATA_SWITCH again will clear the second half of the FIFO and restore the read and write pointers to the situation shown in block A. The switching process (shown in blocks A to D in [Figure 3-13](#)) will continue with each toggle of the ANC_DATA_SWITCH bit.

NOTE: At least 1100 PCLK cycles (41us) must pass between toggles of the ANC_DATA_SWITCH bit. Also, the ANC_DATA_SWITCH bit must be toggled at a point in the video where no extraction is occurring (i.e. the ANC signal is LOW).

By default, the ancillary data is not removed from the video stream. If desired, the ancillary data may be deleted from the video stream after extraction by setting the ANC_DATA_DELETE bit of the host interface HIGH. In this case, all existing ancillary data will be removed and replaced with blanking values. If any of the ANC_TYPE registers are programmed with a DID and/or a DID and SDID, only the ancillary data packets with the matching ID's will be deleted from the video stream.

NOTE: After the ancillary data determined by the ANC_TYPE registers has been deleted, other existing ancillary data may not be contiguous. The device will not concatenate the remaining ancillary data.

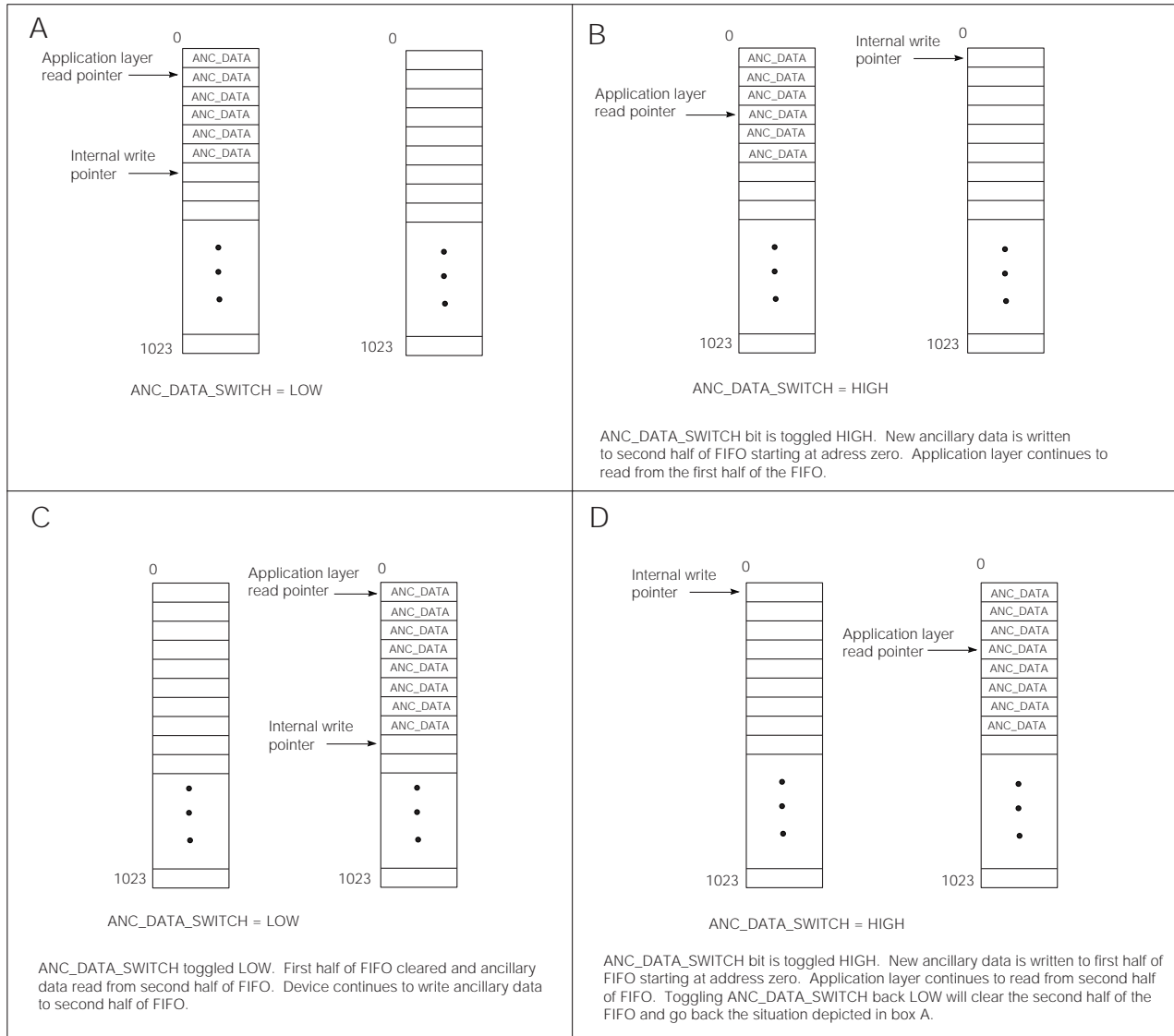

NOTE: At least 1100 PCLK cycles must pass between toggles of the ANC_DATA_SWITCH bit. The bit must be toggled at a point where no extraction is occurring (i.e. the ANC signal is LOW).

Figure 3-13: Ancillary Data Extraction and Reading

3.10.4 Bypass Mode

The internal FIFO is in bypass mode when the FIFO_EN or IOPROC_EN pin is set LOW, or the FIFO_MODE[1:0] bits in the IOPROC_DISABLE register are configured to 11b. By default, the FIFO_MODE[1:0] bits are set to 11b by the device whenever both the SMPTE_BYPASS and DVB_ASI pins are LOW; however, the FIFO_MODE[1:0] bits may be programmed as required.

In bypass mode, the FIFO is not inserted into the video path and data is presented to the output of the device synchronously with the PCLK output. The FIFO will be disabled and placed in static mode to save power.

3.11 Parallel Data Outputs

The parallel data outputs are clocked out of the device on the rising edge of PCLK as shown in Figure 3-14.

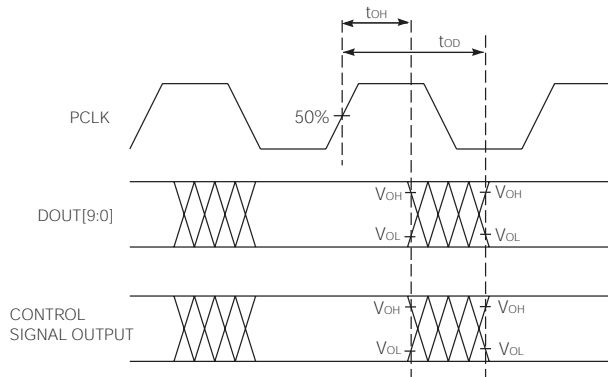

Figure 3-14: PCLK to Data & Control Signal Output Timing

The output data format is defined by the settings of the external SMPTE_BYPASS and DVB_ASI pins (see Table 3-16). In Manual mode, these pins are set as inputs to the device. In Auto mode, the GS9090B sets these pins as output status signals.

Table 3-16: Parallel Data Output Format

Output Data Format	DOUT[9:0]	Pin Settings	
		SMPTE_BYPASS	DVB_ASI
10-bit Data	DATA	LOW	LOW
10-bit Multiplexed SD	Luma / Chroma	HIGH	LOW
10-bit DVB-ASI	DVB-ASI data	LOW	HIGH

3.11.1 Parallel Data Bus Output Buffers

The parallel data outputs of the GS9090B are driven by high-impedance buffers that support both LVTTTL and LVCMOS levels. These buffers use either +1.8V or +3.3V, supplied at the IO_VDD and IO_GND pins. When interfacing with +5V logic levels, the IO_VDD pins should be supplied with +3.3V. For a low power connection, the IO_VDD pins may be connected to +1.8V.

All output buffers, including the PCLK output, will be in a high-impedance state when the $\overline{\text{RESET}}$ signal is asserted LOW.

3.11.2 Parallel Output in SMPTE Mode

When the device is operating in SMPTE mode (see [Section 3.6](#)), SMPTE data is output on the DOUT[9:0] pins.

3.11.3 Parallel Output in DVB-ASI Mode

When operating in DVB-ASI mode (see [Section 3.7](#)), the decoded 8-bit data words will be presented on DOUT[7:0]. DOUT7 = HOUT is the most significant bit of the decoded transport stream data and DOUT0 = AOUT is the least significant bit. DOUT9 will be configured as the DVB-ASI status signal WORDERR and DOUT8 as SYNCOUT. See [Section 3.7.2](#) for a description of these DVB-ASI specific output signals.

3.11.4 Parallel Output in Data-Through Mode

When operating in Data-Through mode (see [Section 3.8](#)), the GS9090B presents data to the output data bus without performing any decoding, descrambling, or word-alignment.

3.12 Programmable Multi-Function Outputs

The GS9090B has a 4-pin multi-function output port, STAT[3:0]. Each pin can be programmed to output one of the following signals: H, V, F, FIFO_LD, ANC, EDH_DETECT, FIFO_FULL, and FIFO_EMPTY.

Table 3-17: Output Signals Available on Multi-Function Output Ports

Output Status Signal	Reference
H	Section 3.6.4
V	Section 3.6.4
F	Section 3.6.4
$\overline{\text{FIFO_LD}}$	Section 3.9.1
ANC	Section 3.9.2
EDH_DETECT	Section 3.9.3

Table 3-17: Output Signals Available on Multi-Function Output Ports

FIFO_FULL	Section 3.10.2.1
FIFO_EMPTY	Section 3.10.2.1

Each of the STAT[3:0] pins can be configured individually using the STAT0_CONFIG[2:0], STAT1_CONFIG[2:0], STAT2_CONFIG[2:0], and STAT3_CONFIG[2:0] registers. Table 3-18 shows the setting of the IO_CONFIG registers for each of the available output signals.

Table 3-18: IO_CONFIG Settings

Function	I/O	IO_CONFIG Setting
H	Output	000b
V	Output	001b
F	Output	010b
$\overline{\text{FIFO_LD}}$	Output	011b
ANC	Output	100b
EDH_DETECT	Output	101b
FIFO_FULL	Output	110b
FIFO_EMPTY	Output	111b

The default setting for each IO_CONFIG register depends on the configuration of the device and the internal FIFO mode selected. This is shown in Table 3-19.

If the programmed signal is not relevant to the current mode of operation, the output will be set to a high-impedance state.

Table 3-19: IO_CONFIG Default Configuration

Device Configuration	IO_CONFIG Register	I/O	Function	Default IO_CONFIG Setting
SMPTE Functionality SMPTE_BYPASS = HIGH DVB_ASI = LOW FIFO: Video Mode or Ancillary Data Extraction Mode	STAT0_CONFIG	Output	H	000b
	STAT1_CONFIG	Output	V	001b
	STAT2_CONFIG	Output	F	010b
	STAT3_CONFIG	Output	$\overline{\text{FIFO_LD}}$	011b
DVB-ASI DVB_ASI = HIGH FIFO: DVB-ASI Mode	STAT0_CONFIG	Output	FIFO_FULL	110b
	STAT1_CONFIG	Output	FIFO_EMPTY	111b
	STAT2_CONFIG	Output	High Z	000b
	STAT3_CONFIG	Output	High Z	000b

Table 3-19: IO_CONFIG Default Configuration

Device Configuration	IO_CONFIG Register	I/O	Function	Default IO_CONFIG Setting
Data-Through SMPTE_BYPASS = LOW DVB_ASI = LOW	STAT0_CONFIG	Output	High Z	000b
	STAT1_CONFIG	Output	High Z	000b
	STAT2_CONFIG	Output	High Z	000b
	STAT3_CONFIG	Output	High Z	000b

3.13 GS9090B Low-latency Mode

When the IOPROC_EN pin is set LOW, the GS9090B will be set into low-latency mode. The parallel data will be output with the minimum PCLK latency possible. The FIFO and all processing blocks except the descrambling and word alignment blocks will be bypassed when SMPTE_BYPASS is HIGH.

Low-latency mode will also be selected when SMPTE_BYPASS is set LOW, regardless of the setting of the IOPROC_EN signal (see [Table 3-20](#)).

In DVB-ASI mode, the device latency is less than in SMPTE mode.

Table 3-20: Pin Settings in Low-latency Mode

IOPROC_EN Setting	SMPTE_BYPASS Setting	Latency (PCLK Cycles)
LOW	LOW	9
HIGH	LOW	10
LOW	HIGH	10
HIGH	HIGH	25

NOTE: Latency applies to parallel processing core only.

When the GS9090B is configured for low-latency mode, the H,V, and F output timing will be based on the incoming TRS codes as shown in Figure 3-15. Active line-based timing is not available and the setting of the H_CONFIG host interface bit will be ignored.

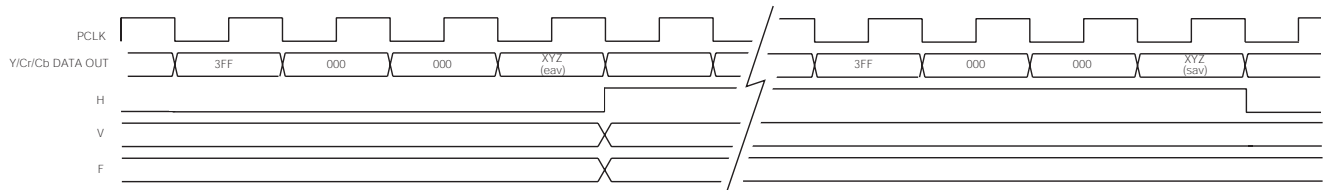

Figure 3-15: H,V,F Timing In Low-latency Mode

3.14 GSPI Host Interface

The GSPI, or Genum Serial Peripheral Interface, is a 4-wire interface provided to allow access to the host interface of the GS9090B and/or to provide additional status information through configuration registers in the device.

The GSPI comprises a serial data input signal SDIN, serial data output signal SDOU, an active low chip select \overline{CS} , and a burst clock SCLK. The burst clock must have a duty cycle between 40% and 60%.

Because these pins are shared with the JTAG interface port, an additional control signal pin JTAG/HOST is provided. When JTAG/HOST is LOW, the GSPI interface is enabled.

When operating in GSPI mode, the SCLK, SDIN, and \overline{CS} signals are provided by the application interface. The SDOU pin is a non-clocked loop-through of SDIN and may be connected to the SDIN of another device, allowing multiple devices to be connected to the GSPI chain. The interface is illustrated in Figure 3-16.

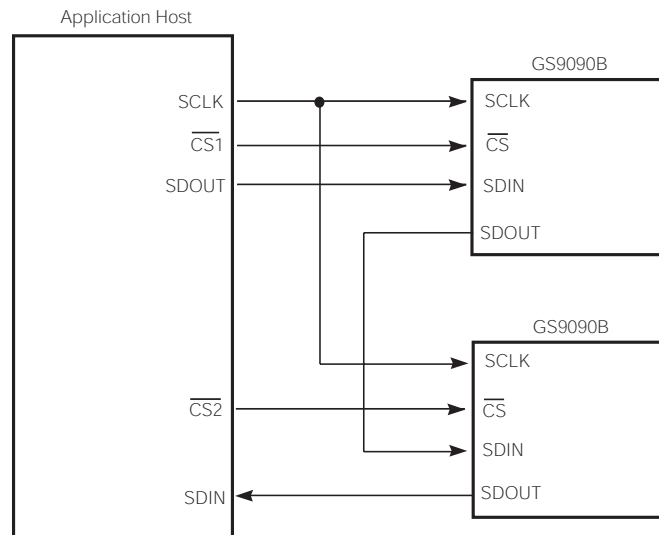

Figure 3-16: GSPI Application Interface Connection

All read or write access to the GS9090B is initiated and terminated by the host processor. Each access always begins with a 16-bit command word on SDIN indicating the address of the register of interest. This is followed by a 16-bit data word on SDIN in write mode, or a 16-bit data word on SDOOUT in read mode.

3.14.1 Command Word Description

The command word consists of a 16-bit word transmitted MSB first and contains a read/write bit, an Auto-Increment bit and a 12-bit address. [Figure 3-17](#) shows the command word format and bit configurations.

Command words are clocked into the GS9090B on the rising edge of the serial clock SCLK, which operates in a burst fashion.

When the Auto-Increment bit is set LOW, each command word must be followed by only one data word to ensure proper operation. If the Auto-Increment bit is set HIGH, the following data word will be written into the address specified in the command word, and subsequent data words will be written into incremental addresses from the previous data word. This facilitates multiple address writes without sending a command word for each data word.

Auto-Increment may be used for both read and write access.

3.14.2 Data Read and Write Timing

Read and write mode timing for the GSPI interface is shown in [Figure 3-19](#) and [Figure 3-20](#) respectively. The timing parameters are defined in [Table 3-21](#).

When several devices are connected to the GSPI chain, only one \overline{CS} must be asserted during a read sequence.

During the write sequence, all command and following data words input at the SDIN pin are output at the SDOOUT pin as is. Where several devices are connected to the GSPI chain, data can be written simultaneously to all the devices that have \overline{CS} set LOW.

Table 3-21: GSPI Timing Parameters

Parameter	Definition	Specification
t_0	The minimum duration of time chip select, \overline{CS} , must be LOW before the first SCLK rising edge.	1.5 ns
t_1	The minimum SCLK period.	12.5 ns
t_2	Duty cycle tolerated by SCLK.	40% to 60%
t_3	Minimum input setup time.	1.5 ns
t_4	Write Cycle: the minimum duration of time between the last SCLK command (or data word if the Auto-Increment bit is HIGH) and the first SCLK of the data word.	37.1 ns
t_5	Read Cycle: the minimum duration of time between the last SCLK command (or data word if the Auto-Increment bit is HIGH) and the first SCLK of the data word.	148.4 ns

Table 3-21: GSPI Timing Parameters (Continued)

Parameter	Definition	Specification
t_5	Read Cycle - FIFO in ANC Extraction Mode: the minimum duration of time between the last SCLK command (or data word if the Auto-Increment bit is HIGH) and the first SCLK of the data word.	222.6 ns
t_6	Minimum output hold time.	1.5 ns
t_7	The minimum duration of time between the last SCLK of the GSPI transaction and when \overline{CS} can be set HIGH.	37.1 ns
t_8	Minimum input hold time.	1.5 ns

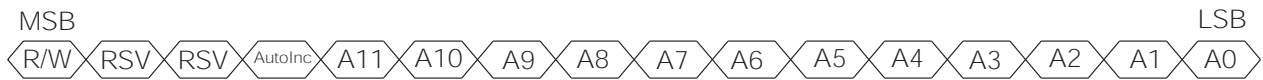

RSV = Reserved. Must be set to zero. R/W: Read command when R/W = 1
Write command when R/W = 0

Figure 3-17: Command Word Format



Figure 3-18: Data Word Format

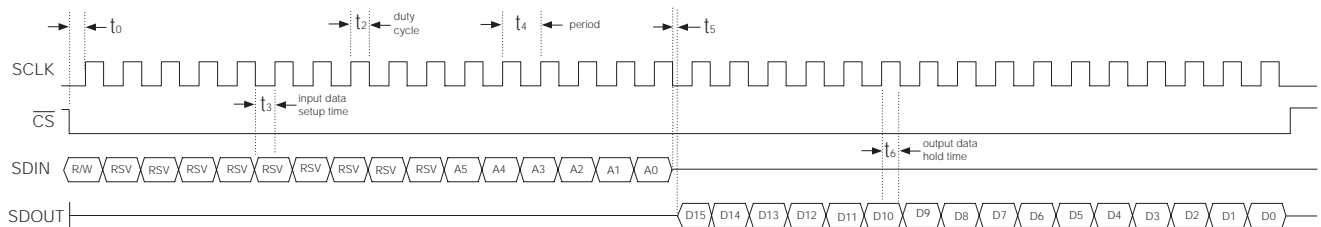

Figure 3-19: GSPI Read Mode Timing

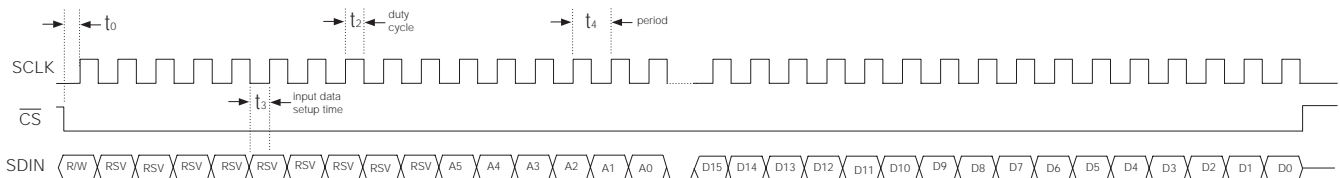

Figure 3-20: GSPI Write Mode Timing

3.14.3 Configuration and Status Registers

Table 3-22 summarizes the GS9090B's internal status and configuration registers.

All of these registers are available to the host via the GSPI and are all individually addressable.

Where status registers contain less than the full 16 bits of information, two or more registers may be combined at a single logical address.

Table 3-22: GS9090B Internal Registers

Address	Register Name	Reference
00h	IOPROC_DISABLE	Section 3.9.8
01h	ERROR_STATUS	Section 3.9.7
02h	EDH_FLAG_IN	Section 3.9.4
03h	EDH_FLAG_OUT	Section 3.9.4
04h	DATA_FORMAT	Section 3.9.6.1
05h	IO_CONFIG	Section 3.12
06h	FIFO_EMPTY_OFFSET	Section 3.10.2.1
07h	FIFO_FULL_OFFSET	Section 3.10.2.1
08h - 0Eh	ANC_TYPE	Section 3.9.2
11h - 14h	RASTER_STRUCTURE	Section 3.9.6
15h - 24h	EDH_CALC_RANGES	Section 3.9.7.2
25h	ERROR_MASK	Section 3.9.7
28h	FIFO_LD_POSITION	Section 3.9.1.1
02Ch - 42Bh	INTERNAL FIFO	Section 3.10.3

3.15 JTAG Operation

When the JTAG/ $\overline{\text{HOST}}$ pin is set HIGH, the host interface port (as described in [Section 3.14](#)) will be configured for JTAG test operation. In this mode, pins 16, 17, 19, and 20 become TMS, TCK, TDO, and TDI respectively. In addition, the $\overline{\text{RESET}}$ pin will operate as the test reset pin, as well as resetting the internal registers.

Boundary scan testing using the JTAG interface will be possible in this mode.

There are two methods in which JTAG can be used on the GS9090B:

1. As a stand-alone JTAG interface to be used at in-circuit ATE (Automatic Test Equipment) during PCB assembly; or
2. Under control of the host for applications such as system power self tests.

When the JTAG tests are applied by ATE, care must be taken to disable any other devices driving the digital I/O pins. If the tests are to be applied only at ATE, this

can be accomplished with tri-state buffers used in conjunction with the $\overline{\text{JTAG/HOST}}$ input signal. This is shown in Figure 3-21.

Alternatively, if the test capabilities are to be used in the system, the host may still control the $\overline{\text{JTAG/HOST}}$ input signal, but some means for tri-stating the host must exist in order to use the interface at ATE. This is represented in Figure 3-22.

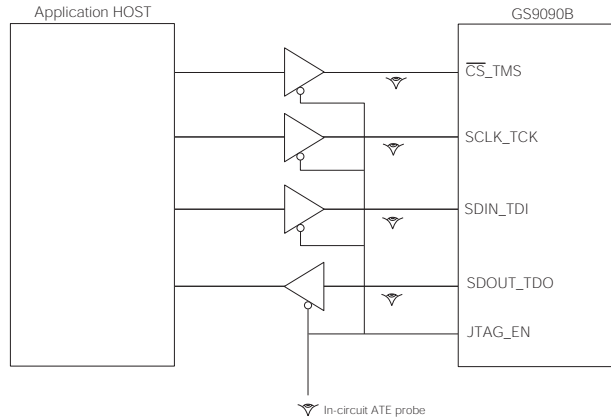

Figure 3-21: In-Circuit JTAG

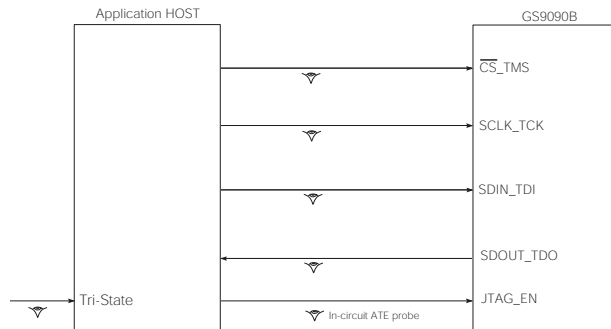

Figure 3-22: System JTAG

3.16 Device Power Up

The GS9090B has a recommended power supply sequence. To ensure correct power up, power the CORE_VDD pins before the IO_VDD pins. In order to initialize all internal operating conditions to their default state the $\overline{\text{RESET}}$ pin must be held LOW for a minimum of $t_{\text{reset}} = 1\text{ms}$. (See Figure 3-23)

Device pins can be driven prior to power up without causing damage.

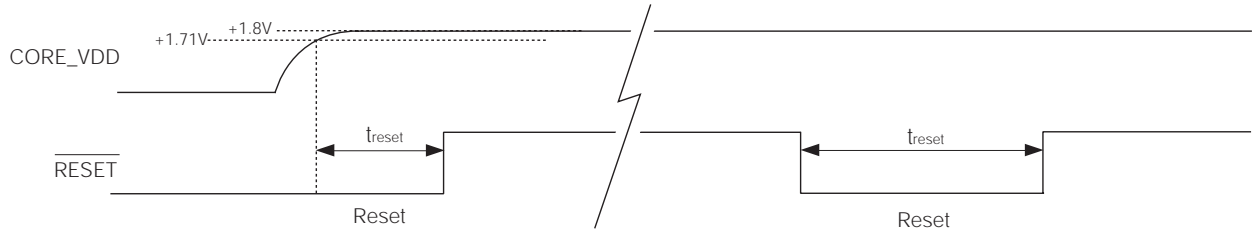

Figure 3-23: Reset pulse

4. References & Relevant Standards

SMPTE 125M	Component video signal 4:2:2 – bit parallel interface
SMPTE 259M	10-Bit 4:2:2 Component and $4f_{SC}$ Composite Digital Signals - Serial Digital Interface
SMPTE 291M	Ancillary Data Packet and Space Formatting
SMPTE 293M	720 x 483 active line at 59.94 Hz progressive scan production – digital representation
SMPTE 305.2M	Serial Data Transport Interface
SMPTE 352M	Video Payload Identification for Digital Television Interfaces
SMPTE RP165	Error Detection Checkwords and Status Flags for Use in Bit-Serial Digital Interfaces for Television
SMPTE RP168	Definition of Vertical Interval Switching Point for Synchronous Video Switching

5. Application Information

5.1 Typical Application Circuit (Part A)

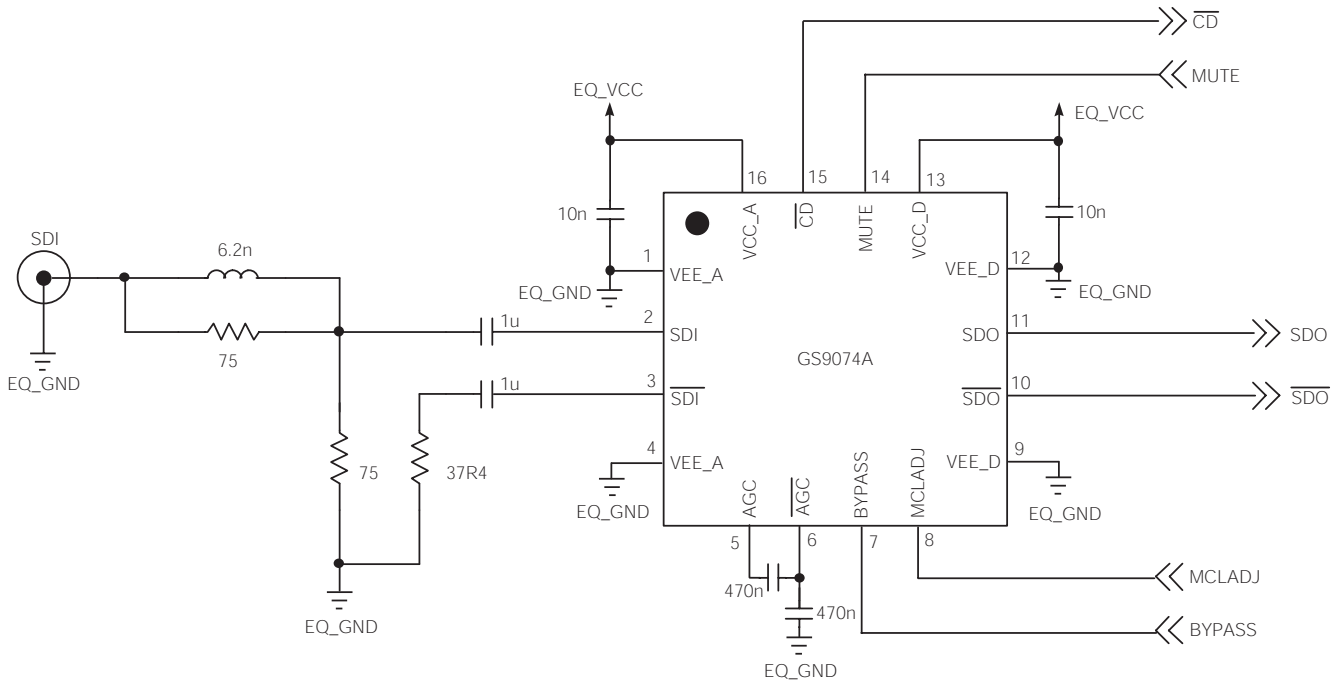

NOTE: All resistors in Ohms, capacitors in Farads, and inductors in Henrys, unless otherwise noted.

NOTE: For up-to-date component values and detailed operation of the equalizer, please see the GS9074A data sheet.

5.2 Typical Application Circuit (Part B)

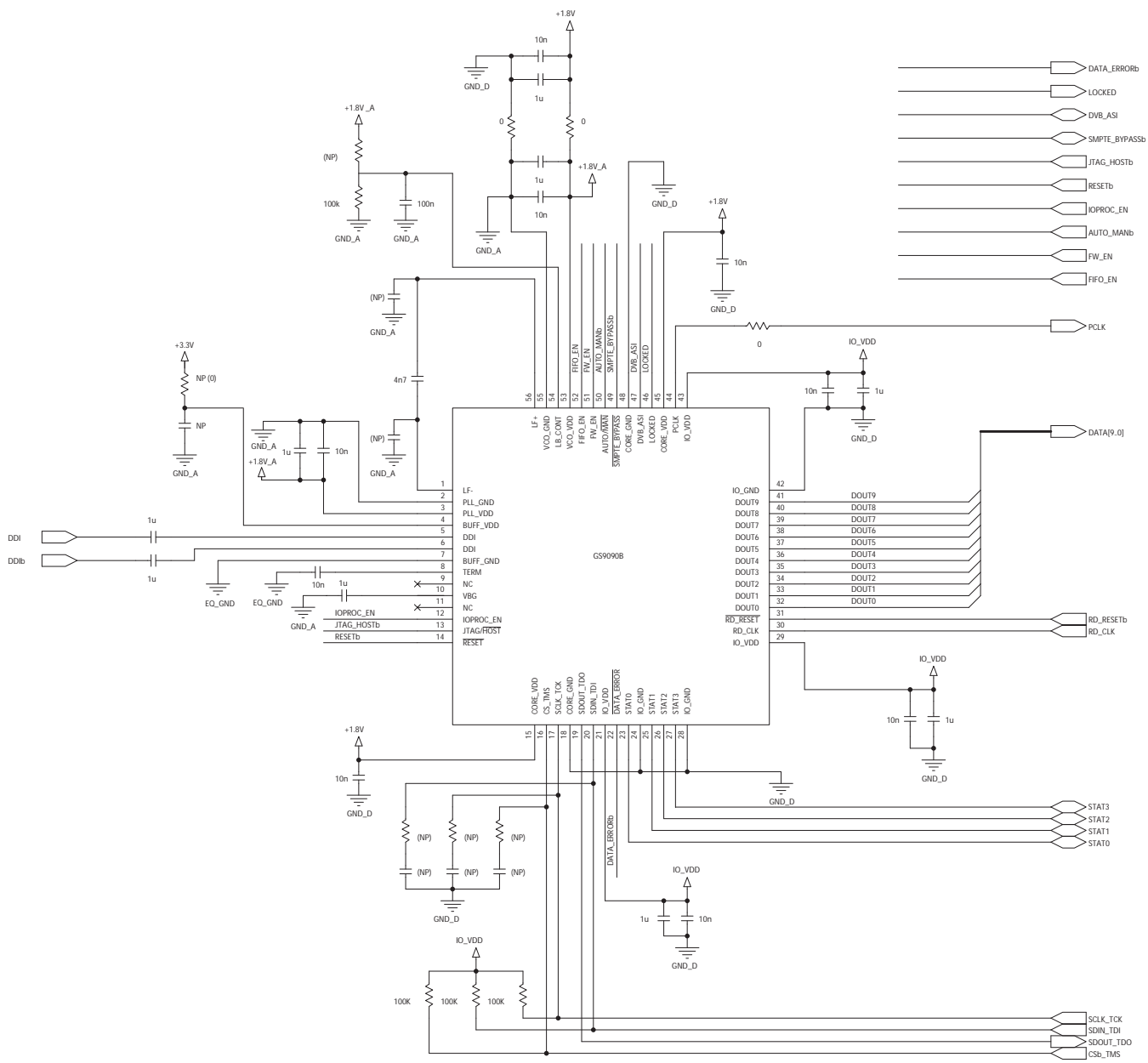

6. Package & Ordering Information

6.1 Package Dimensions

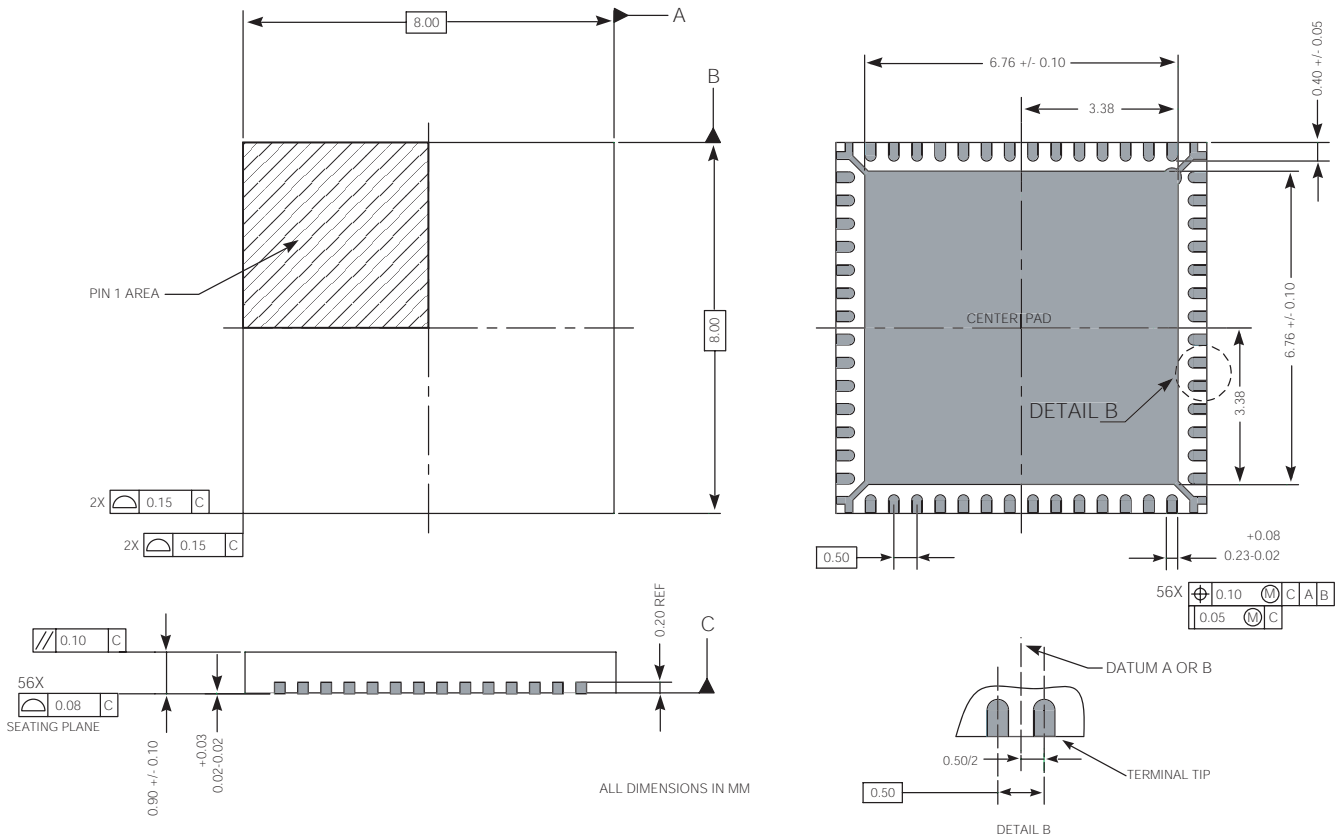

6.2 Recommended PCB Footprint

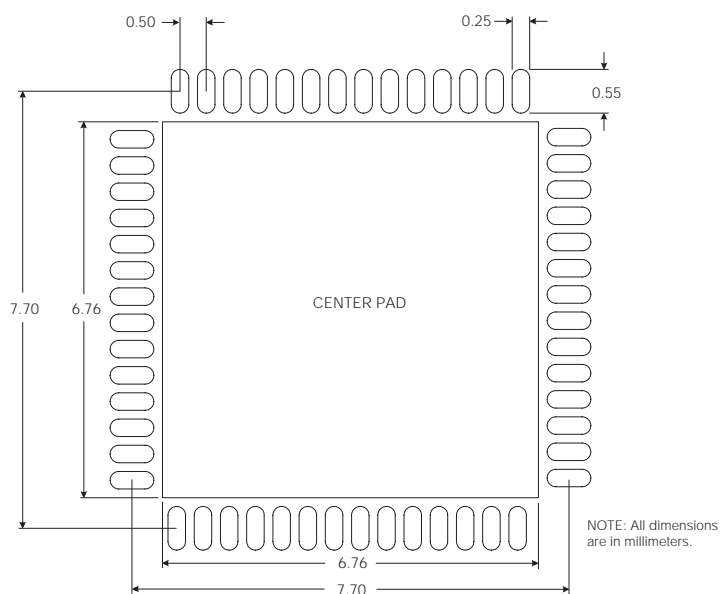

The Center Pad of the PCB footprint should be connected to the CORE_GND plane by a minimum of 25 vias.

NOTE: Suggested dimensions only. Final dimensions should conform to customer design rules and process optimizations.

6.3 Packaging Data

Parameter	Value
Package Type	8mm x 8mm 56-pin QFN
Package Drawing Reference	JEDEC M0220
Moisture Sensitivity Level	3
Junction to Case Thermal Resistance, θ_{j-c}	12.2°C/W
Junction to Air Thermal Resistance, θ_{j-a} (at zero airflow)	25.8°C/W
Psi, Ψ	9.1°C/W
Pb-free and RoHS compliant	Yes

6.4 Marking Diagram

Pin 1 ID



XXXX - Lot/Work Order ID

YYWW - Date Code

YY - 2-digit year

WW - 2-digit week number

6.5 Ordering Information

Part Number	Package	Temperature Range
GS9090BCNE3	56-pin QFN	0°C to 70°C

7. Revision History

Version	ECR	Date	Changes and/or Modifications
0	141913	September 2006	New Document.
1	143101	December 2006	Converting to data sheet. Removed 'Proprietary and Confidential' footer. Added section 6.4 Marking Diagram .
2	143668	January 2007	Added DVB-ASI payload data rate parameter to Table 2-3: AC Electrical Characteristics .

CAUTION

ELECTROSTATIC SENSITIVE DEVICES
DO NOT OPEN PACKAGES OR HANDLE
EXCEPT AT A STATIC-FREE WORKSTATION



DOCUMENT IDENTIFICATION

DATA SHEET

The product is in production. Gennum reserves the right to make changes to the product at any time without notice to improve reliability, function or design, in order to provide the best product possible.

GENNUM CORPORATION

Mailing Address: P.O. Box 489, Stn. A, Burlington, Ontario, Canada L7R 3Y3
Shipping Address: 970 Fraser Drive, Burlington, Ontario, Canada L7L 5P5
Tel. +1 (905) 632-2996 Fax. +1 (905) 632-5946

GENNUM JAPAN CORPORATION

Shinjuku Green Tower Building 27F, 6-14-1, Nishi Shinjuku, Shinjuku-ku, Tokyo, 160-0023 Japan
Tel. +81 (03) 3349-5501, Fax. +81 (03) 3349-5505

GENNUM UK LIMITED

25 Long Garden Walk, Farnham, Surrey, England GU9 7HX
Tel. +44 (0)1252 747 000 Fax +44 (0)1252 726 523

Gennum Corporation assumes no liability for any errors or omissions in this document, or for the use of the circuits or devices described herein. The sale of the circuit or device described herein does not imply any patent license, and Gennum makes no representation that the circuit or device is free from patent infringement.

GENNUM and the G logo are registered trademarks of Gennum Corporation.

© Copyright 2006 Gennum Corporation. All rights reserved. Printed in Canada.

www.gennum.com