



GENNUM
CORPORATION

GX4314 Wideband, Monolithic 4x1 Video Multiplexer

DATA SHEET

FEATURES

- low differential phase and gain
- wide bandwidth, 100 MHz at -1 dB (Flattened)
- small switching transient
- ± 4.5 to ± 11 volts supplies

FUNCTIONAL BLOCK DIAGRAM

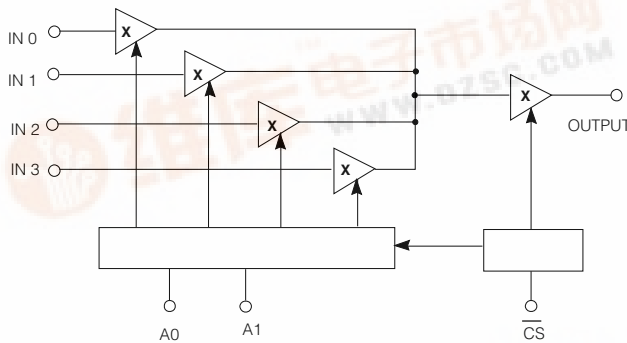

GX4314

TRUTH TABLE

\overline{CS}	A1	A0	OUTPUT
0	0	0	IN 0
0	0	1	IN 1
0	1	0	IN 2
0	1	1	IN 3
1	X	X	HI - Z

X = DON'T CARE

AVAILABLE PACKAGING

- 14 pin PDIP
- 14 pin SOIC

CIRCUIT DESCRIPTION

The GX4314 is a wideband video multiplexer implemented in bipolar technology. This device is characterized by excellent differential phase and gain in the enabled state, very high off-isolation in the disabled state and fully buffered unilateral signal path. Make-before-break switching assures virtually glitch-free switching.

For use in NxM routing matrices, the GX4314 features a very high, nearly constant input impedance coupled with high output impedance in the disabled state. This allows multiple devices to be paralleled at the inputs and outputs without additional circuitry.

Logic inputs are TTL and 5V CMOS compatible, providing address and chip select functions. The operation of the devices is described in the Truth Table below.

The wideband GX4314 is pin for pin compatible with the high performance GX414, extending the flat frequency response characteristics from 50 to 100 MHz.

APPLICATIONS

- HDTV
- Very high quality video switching
- Very high density video switching
- Computer graphics
- PCM / data routing

ORDERING INFORMATION

Part Number	Package Type	Temperature Range
GX4314 - CDB	14 pin PDIP	0 to 70°C
GX4314 - CKB	14 pin SOIC	0 to 70°C

CAUTION

ELECTROSTATIC
SENSITIVE DEVICES
DO NOT OPEN PACKAGES OR HANDLE
EXCEPT AT A STATIC-FREE WORKSTATION



ABSOLUTE MAXIMUM RATINGS

Parameter	Value
Supply Voltage	$\pm 13.5V$
Operating Temperature Range	$0^{\circ}C$ T_A $70^{\circ}C$
Storage Temperature Range	$-65^{\circ}C$ T_S $150^{\circ}C$
Lead Temperature (Soldering, 10 Sec)	$260^{\circ}C$
Analog Input Voltage	$(V_{EE} - 1.4)$ or $-7.5 < V_A < (V_{CC} + 0.3)$ or $(V_{EE} + 15) V$
Logic Input Voltage	$-0.5V$ V_L $+5.5V$

PIN CONNECTIONS

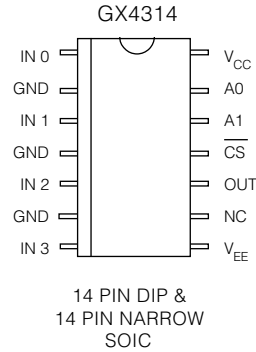

ELECTRICAL CHARACTERISTICS $(V_S = \pm 8V$ DC, $0^{\circ}C < T_A < 70^{\circ}C$, $R_L = 10k\ \Omega$, $C_L = 30$ pF, unless otherwise shown.)

	PARAMETER	SYMBOL	CONDITIONS	MIN	TYP	MAX	UNITS
DC SUPPLY	Supply Voltage	$\pm V_S$	Operating Range	± 4.5	-	± 11	V
	Supply Current	I^+	$\overline{CS} = 0$	-	22	25	mA
		I^-	$\overline{CS} = 0$	-	22	25	mA
		I^+	$\overline{CS} = 1$	-	270	350	A
I^-		$\overline{CS} = 1$	-	350	600	A	
STATIC	Analog Output Voltage Swing	V_{OUT}	Extremes before clipping occurs	-2.4	-	2.6	V
	Analog Input Bias Current	I_{BIAS}		-	11	-	A
	Output Offset Voltage	V_{OS}	$T_A = 25^{\circ}C$	7	14	21	mV
	Output Offset Voltage Drift	V_{OS}		-	160	-	V/ $^{\circ}C$
LOGIC	Chip Enable Time	t_{ON}	Enable input to appearance of signal	-	200	400	ns
	Chip Disable Time	t_{OFF}	Enable input to disappearance of signal at output.	0.6	1.2	-	s
	Logic Input Thresholds	V_{IH}	1	2.0	-	-	V
		V_{IL}	0	-	-	0.8	V
Logic Input Current	I_L		-	-	4	A	
DYNAMIC	Insertion Loss	I.L.	1V p-p sine or sq. wave at 100 kHz	0.025	0.038	0.050	dB
	Bandwidth (-3dB)	B.W.	small signal $C_L = 0$ pF	-	300	-	MHz
	Input Resistance	R_{IN}	$\overline{CS} = 0$, crosspoint on	0.5	-	-	M
	Input Capacitance	C_{IN}	$\overline{CS} = 0$, crosspoint on	-	1.4	-	pF
	Output Resistance	R_{OUT}	$\overline{CS} = 0$, crosspoint on	-	6	-	
	Output Capacitance	C_{OUT}	$\overline{CS} = 1$, chip disabled	-	2.6	-	pF
	Differential Gain	dg	$f = 3.58$ MHz, $V_{IN} = 40$ IRE	-	-	0.03	%
	Differential Phase	dp	$f = 3.58$ MHz, $V_{IN} = 40$ IRE	-	-	0.02	deg
	All Hostile Crosstalk	$XTLK_{AH}$	1Vp-p on 3 inputs 4th input has 10 resistor to gnd $f=30$ MHz	-	70	-	dB
	Chip Disabled Crosstalk	$XTLK_{CD}$	Enabled device on O/P $f=100$ MHz	-	80	-	dB
	Slew Rate	+SR	$V_{IN} = 1V$ p-p ($C_L = 10$ pF)	1000	1500	-	V/ s
		-SR	$V_{IN} = 1V$ p-p ($C_L = 10$ pF)	440	660	-	V/ s
	Gain Spread at 30 MHz	A_V		-	-	± 0.05	dB
	Crosspoint Scatter		$R_S = 75$	$T_A = 25^{\circ}C$	-	-	± 0.15
$f = 3.58$ MHz			$0^{\circ}C < T_A < 70^{\circ}C$	-	-	± 0.25	deg

TYPICAL PERFORMANCE CURVES FOR GX4314

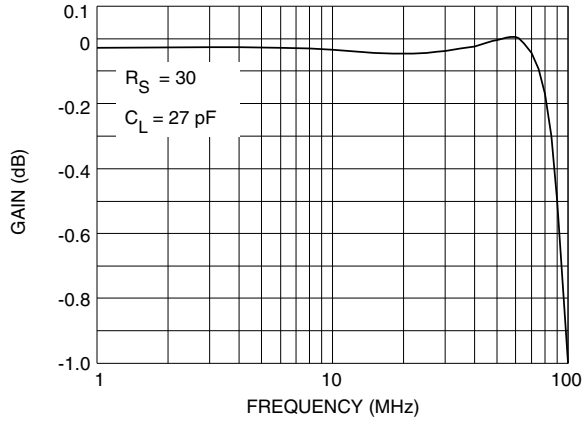

Fig. 1 Flattened Frequency Response

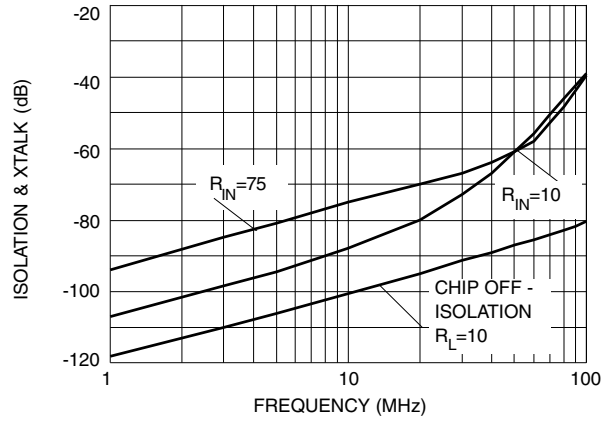

Fig. 2 All Hostile Crosstalk & Isolation

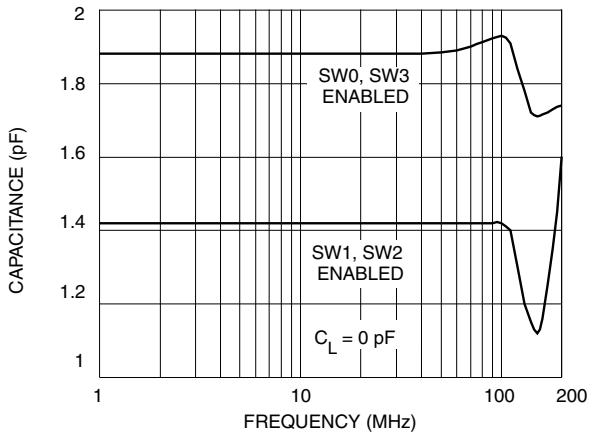

Fig. 3 Input Capacitance

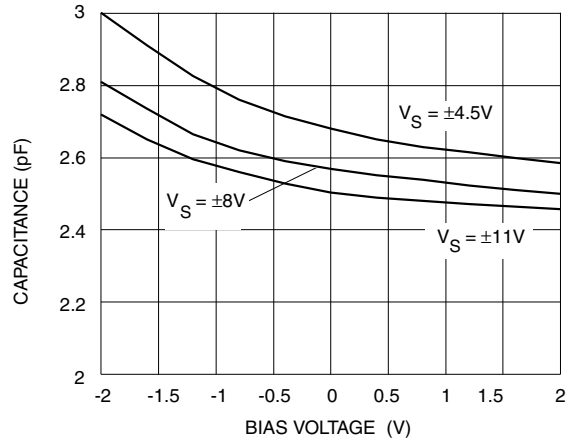

Fig. 4 Output Capacitance

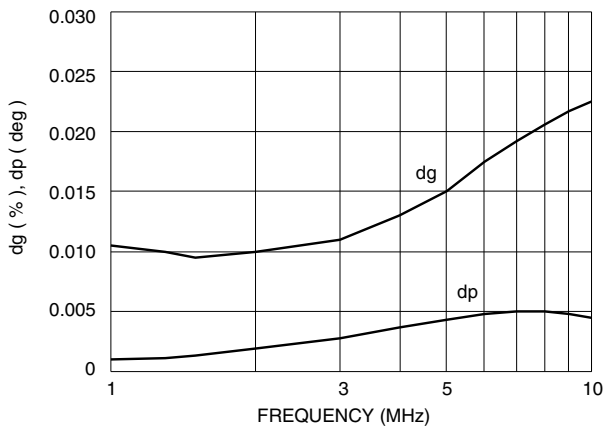

Fig. 5 Differential Gain & Phase

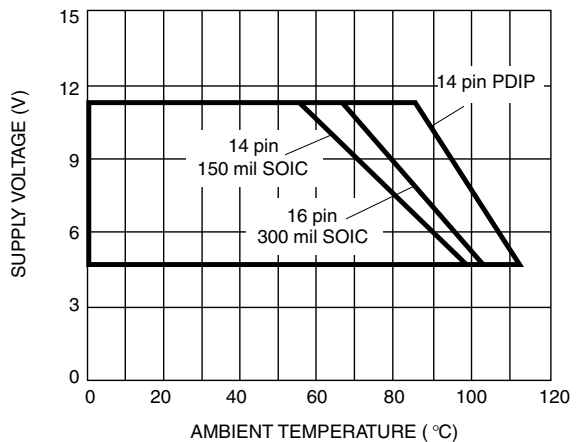

Fig. 6 Safe Operating Area for GX4314
(All packages)

NOTE: Curves are based on 25 mA max. supply current and 130 $^{\circ}$ C max. junction temperature.

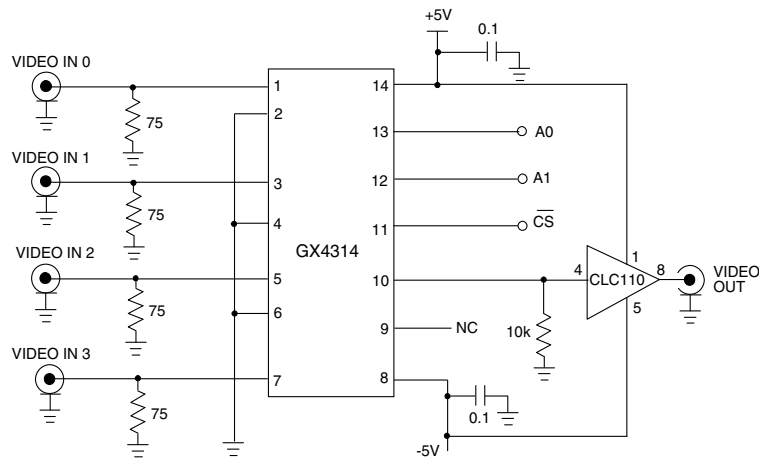
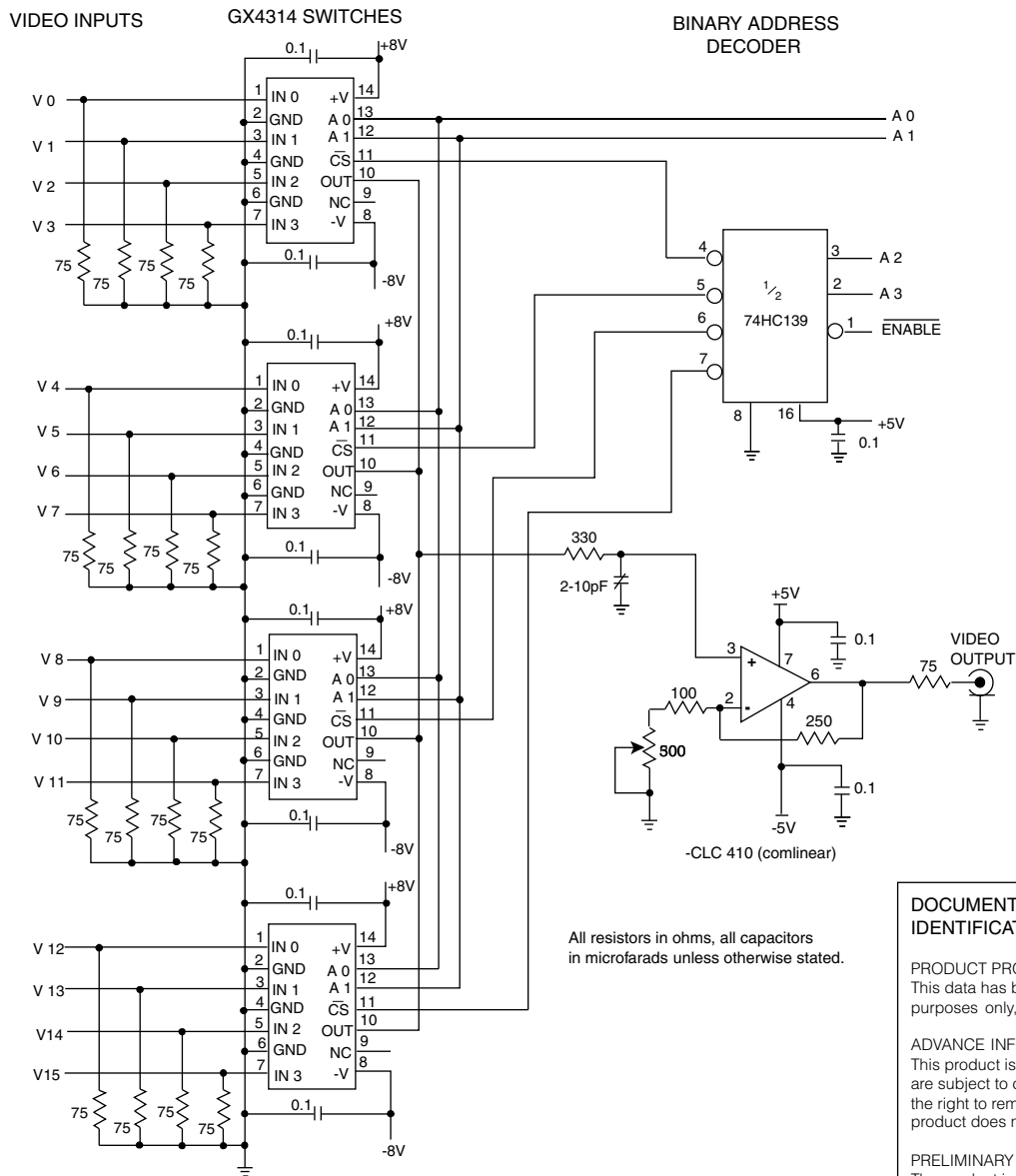

Fig. 7 Test Circuit



All resistors in ohms, all capacitors in microfarads unless otherwise stated.

DOCUMENT IDENTIFICATION

PRODUCT PROPOSAL

This data has been compiled for market investigation purposes only, and does not constitute an offer for sale.

ADVANCE INFORMATION NOTE

This product is in development phase and specifications are subject to change without notice. Gennum reserves the right to remove the product at any time. Listing the product does not constitute an offer for sale.

PRELIMINARY DATA SHEET

The product is in a preproduction phase and specifications are subject to change without notice.

DATA SHEET

The product is in production. Gennum reserves the right to make changes at any time to improve reliability, function or design, in order to provide the best product possible.

Fig. 8 16 x 1 Video Multiplexer Circuit