



Global Mixed-mode Technology Inc.

G1213

Low power, Single, SOT-23-5, Rail-to-rail OP Amp

Features

- Single-Supply Operation: 4V to 6V
- High Output Current: $\pm 100\text{mA}$
- Low Supply Current: $500\mu\text{A}$
- Wide Bandwidth: 3MHz
- Slew Rate: $4\text{V}/\mu\text{s}$
- No Phase Reversal
- Unity Gain Stable
- Small, 5-Pin SOT-23 Package available

Applications

- Battery-Powered Instruments
- Portable Equipment
- Data-Acquisition Systems
- High-Side/Low-Side Current Sensors
- ASIC Input or Output Amplifier
- Signal Conditioning
- Low-Power, Low voltage Applications

General Description

The G1213 is a rail-to-rail input and output single-supply amplifiers featuring 100mA output drive current. This high output current makes these amplifiers excellent for driving either resistive or capacitive loads. AC performance is very good with 3.0MHz bandwidth; $4.0\text{V}/\mu\text{s}$ slew rate and low distortion. All are guaranteed to operate from a +4 to +6 volt single supply.

The very low input bias currents enable the G1213 to be used for integrators and diode amplification and other applications requiring low input bias current. The 100mA high output current and supply current is only $850\mu\text{A}$ per amplifier at 5 volts, allowing low current applications to control high current loads.

Applications include audio amplification for computers, sound ports, sound cards and set-top boxes. The G1213 is very stable and capable of driving heavy capacitive loads. The ability to swing rail-to-rail at the inputs and outputs enables designers to buffer CMOS ADC/DACs, ASICs or other wide output swing devices in single-supply systems.

Ordering Information

ORDER NUMBER	ORDER NUMBER (Pb free)	MARKING	TEMP. RANGE	PACKAGE
G1213	G1213f	13xx	-20°C to +85°C	SOT-23-5

Pin Configuration

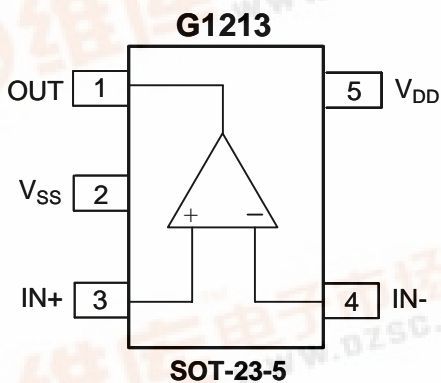

Typical Application Circuit

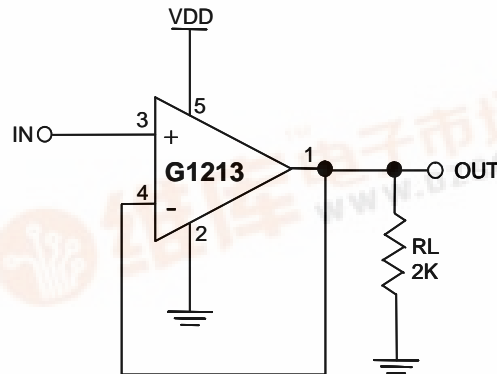

**Absolute Maximum Ratings (Note1)**

Supply Voltage (V_{DD} to V_{SS}).....+7.0V	Operating Ambient Temperature-20°C to +85°C
All Other Pins.....(V_{SS} -0.3V) to (V_{DD} +0.3V)	Storage Temperature Range.....-65°C to +150°C

Notes:

1. Absolute Maximum Ratings are limits beyond which damage to the device may occur.

Thermal Characteristics

PARAMETER	SYMBOL	VALUE	UNIT
Thermal resistance from junction to ambient in free air SOT-23-5	R_{thj-a}	240	°C/W

Electrical Characteristics

$V_{DD} = 5V$; $V_{SS} = 0V$; $T_{amb} = 25°C$; $f_i = 1kHz$; $V_{CM} = V_{DD}/2$, $R_L = 2K\Omega$ connected to $V_{DD}/2$; unless otherwise specified.

PARAMETER	SYMBOL	CONDITIONS	MIN.	TYP.	MAX.	UNIT
Supplies						
Supply voltage	V_{DD}		4.0	5.0	6.0	V
Single			4.0	5.0	6.0	V
Dual			2	2.5	3.0	V
Negative supply voltage (dual)	V_{SS}		-2.0	-2.5	-3.0	V
Supply current	I_{DD}	no load	---	0.85	1.2	mA
Total power dissipation	P_{tot}	no load	---	4.25	6.0	mW
DC Characteristics						
Input offset voltage	$V_{I(OS)}$		---	±1.5	±6	mV
Common mode voltage	V_{CM}		0		5.0	V
Input Bias Current	I_B		---	±0.05	---	nA
Input Bias Current Offset	I_{OS}		---	±0.05	---	nA
Input Resistance	R_{IN}		---	1000	---	MΩ
Large-Signal Voltage Gain	A_V		---	80	---	dB
Maximum output current	I_O		---	100	---	mA
Output resistance	R_O	Open-loop, $R_L = 20\Omega$	---	5.5	---	Ω
Output voltage swing	V_O	$R_L = 32\Omega$	1.0	---	4.0	V
		$R_L = 2k\Omega$	0.1	---	4.9	V
Power supply rejection ratio	PSRR	$f_i = 1kHz$; $V_{ripple(peak)} = 1V$	---	60	---	dB
Common-Mode Rejection Ratio	CMRR		---	56	---	dB
AC Characteristics						
Total harmonic distortion	THD	Note 2	---	< 0.1	---	%
		$R_L = 2k\Omega$, Note 2				
Gain-Bandwidth Product	GBWP	Open-loop; No Load	---	3.0	---	MHz
Slew-Rate	SR	Measured from 30% to 70% of 5Vp-p step	---	4	---	V/μs
Phase Margin	PM		---	60	---	deg
Maximum output power	P_O	Note 1; $R_L = 32\Omega$	---	135	---	mW
Power bandwidth	B	Unity gain; $R_L = 32\Omega$	---	25	---	KHz

Notes:

- Values are proportional to V_{DD} ; THD < 0.1%
- $V_{DD} = 5.0V$; $V_{O(P-P)} = 4.0V$ (at 0 dB)

Output Swing Range Voltage Figure

Test Condition : $T_A = 25^\circ\text{C}$, $A_V = -1$

$V_+ = 2.5\text{V}$, $V_- = -2.5\text{V}$, $R_L = 2\text{k}\Omega$

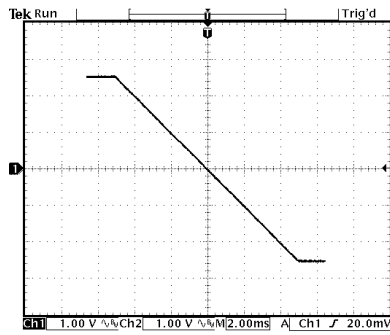

$V_+ = 2.5\text{V}$, $V_- = -2.5\text{V}$, $R_L = 250\Omega$

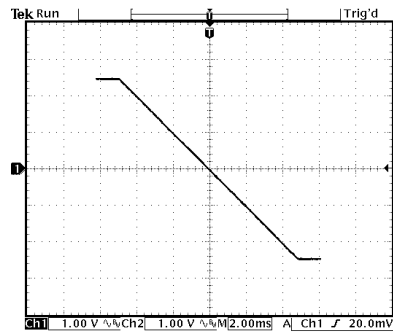

$V_+ = 2.5\text{V}$, $V_- = -2.5\text{V}$, $R_L = 32\Omega$

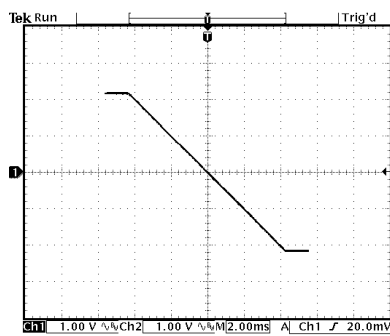

$V_+ = 2.5\text{V}$, $V_- = -2.5\text{V}$, $R_L = 16\Omega$

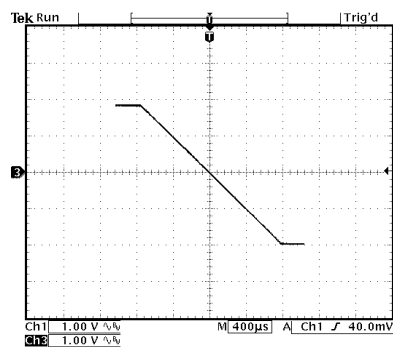

Input Common Mode Voltage Range Figure

Test Condition : $T_A = 25^\circ\text{C}$, $A_V = 1$

$V_+ = 5\text{V}$, $V_- = 0\text{V}$, $R_L = 2\text{K}\Omega$

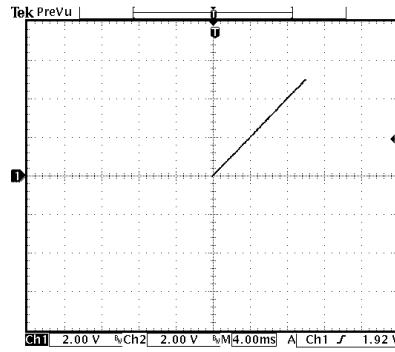
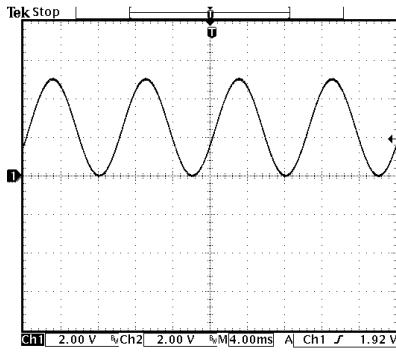

$V_+ = 5\text{V}$, $V_- = 0\text{V}$, $R_L = 250\Omega$

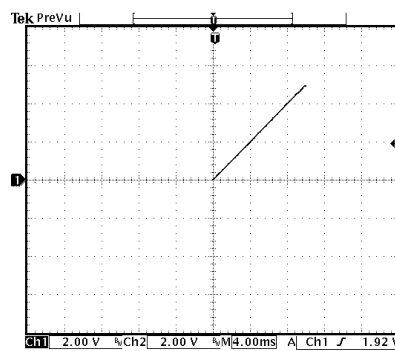
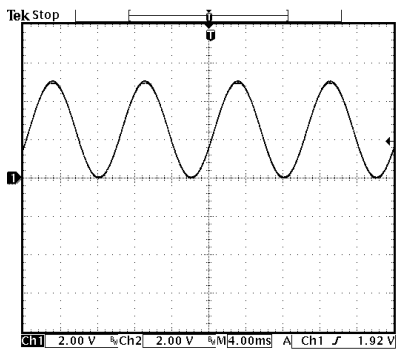

Large Signal Transient Response Figure

Test Condition : TA=25°C, AV=1 , RL = 2kΩ

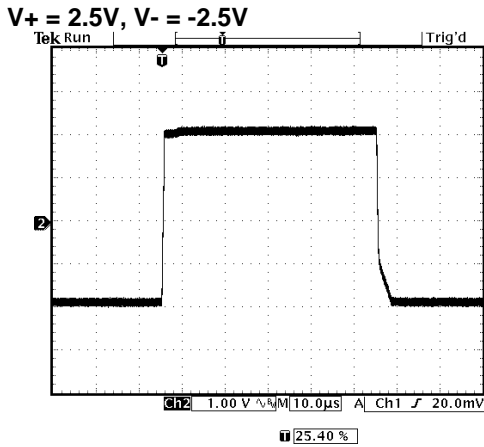

Small Signal Transient Response Figure

Test Condition : TA=25°C, AV=1, RL = 32Ω

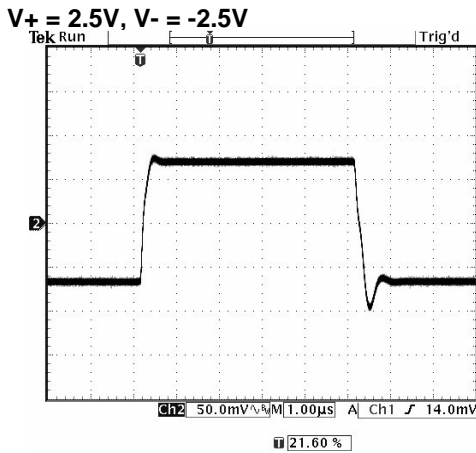

Test Condition: Vs = ±2.5V, TA = 25°C

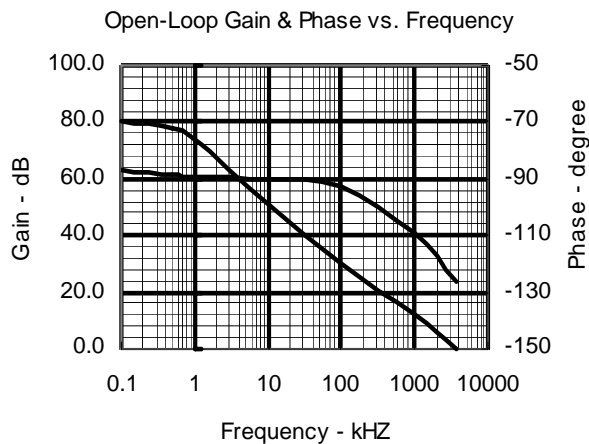

Test Condition: Vs = ±2.5V, TA = 25°C

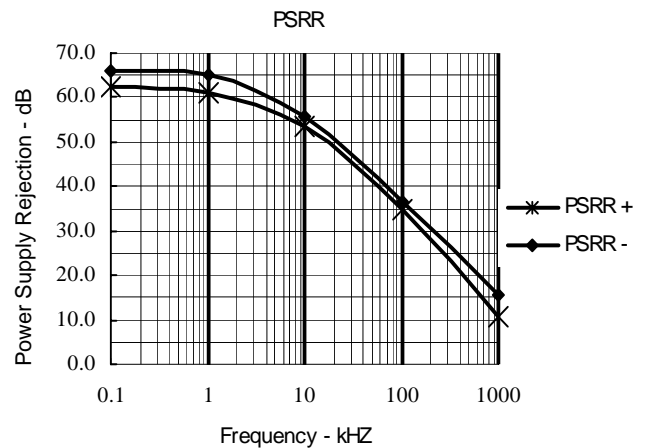



Package Information

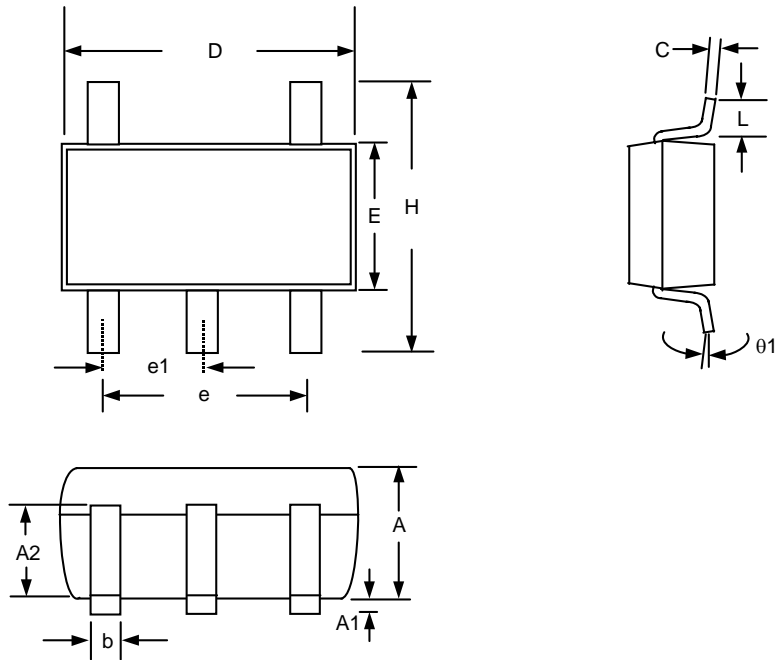

Note:

1. Package body sizes exclude mold flash protrusions or gate burrs
2. Tolerance ± 0.1000 mm (4mil) unless otherwise specified
3. Coplanarity: 0.1000mm
4. Dimension L is measured in gage plane

SYMBOL	DIMENSION IN MM			DIMENSION IN INCH		
	MIN.	NOM.	MAX.	MIN.	NOM.	MAX.
A	1.00	1.10	1.30	0.039	0.043	0.051
A1	0.00	-----	0.10	0.000	-----	0.004
A2	0.70	0.80	0.90	0.028	0.031	0.035
b	0.35	0.40	0.50	0.014	0.016	0.020
C	0.10	0.15	0.25	0.004	0.006	0.010
D	2.70	2.90	3.10	0.106	0.114	0.122
E	1.40	1.60	1.80	0.055	0.063	0.071
e	-----	1.90(TYP)	-----	-----	0.075(TYP)	-----
H	2.60	2.80	3.00	0.102	0.110	0.118
L	0.37	-----	-----	0.015	-----	-----
$\theta 1$	1°	5°	9°	1°	5°	9°

Taping Specification

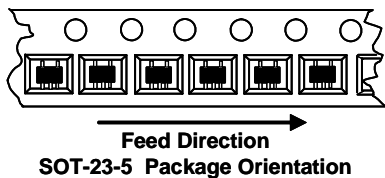

PACKAGE	Q'TY/REEL
SOT-23-5	3,000 ea