

GTM CORPORATION

ISSUED DATE :2003/05/15
REVISED DATE :2004/11/10B

G431 Adjustable Shunt Regulator

Description

The G431 series are three-terminal adjustable regulators with guaranteed thermal stability over applicable temperature ranges. The output voltage may be set to any value between VREF (approximately 2.495v) and 36v with two external resistors. It provides very wide applications, including shunt regulator, series regulator, switching regulator, voltage reference and others.

Package Dimensions

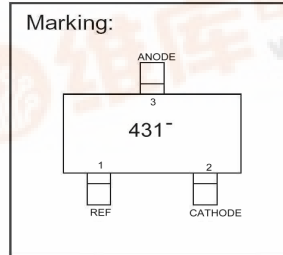
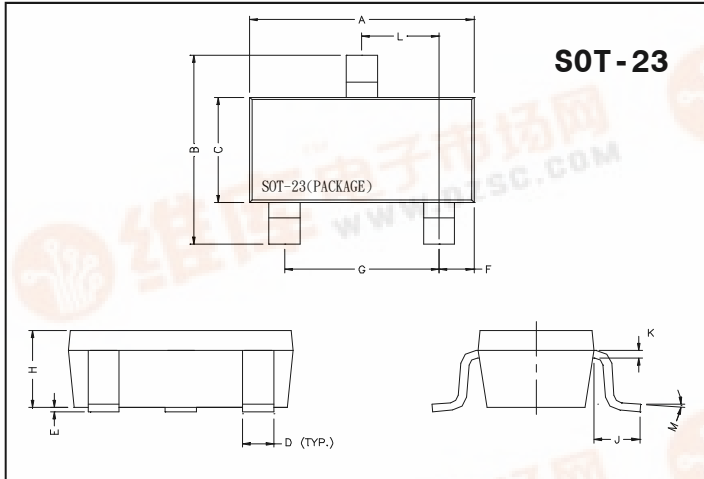

REF.	Millimeter		REF.	Millimeter	
	Min.	Max.		Min.	Max.
A	2.70	3.10	G	1.90	REF.
B	2.40	2.80	H	1.00	1.30
C	1.40	1.60	K	0.10	0.20
D	0.35	0.50	J	0.40	-
E	0	0.10	L	0.85	1.15
F	0.45	0.55	M	0°	10°

Absolute Maximum Ratings at Ta = 25°C

Parameter	Symbol	Ratings	Unit
Junction Temperature	Tj	+150	°C
Storage Temperature	Tstg	-65 ~ +150	°C
Cathode Voltage	VKA	37	V
Cathode Current Range(Continuous)	IkA	-100~+150	mA
Reference Input Current Range	IREF	-0.05~+10	mA
Total Power Dissipation	PD	225	mW

Characteristics at Ta = 25°C

Parameter	Symbol	Min	Typ.	Max.	Unit	Test Conditions
Cathode Voltage	VKA	VREF	-	36	V	
Cathode Current	IkA	1	-	100	mA	
Reference Input Voltage	VREF	2.445	2.495	2.545	V	VKA= VREF, Ik=10mA
G431C		2.470	2.495	2.520		
G431A		2.483	2.495	2.507		
Deviation of reference Input Voltage Over temperature(note)	$\Delta V_{REF}/\Delta T$	-	4.5	17	mV	VKA=VREF, Ik=10mA Tmin ≤ Ta ≤ Tmax
Ratio of Change in Reference Input Voltage to the Change in Cathode Voltage	$\Delta V_{REF}/\Delta V_{KA}$	-	-1.0	-2.7	mV/V	Ik=10mA $\Delta V_{KA}=10V-V_{REF}$ $\Delta V_{KA}=36V-10V$
		-	-0.5	-2.0		
Reference Input Current	IREF	-	1.5	4	uA	Ik=10mA, R1=10KΩ, R2=∞
Deviation of reference Input Current Over Full Temperature Range	$\Delta I_{REF}/\Delta T$	-	0.4	1.2	uA	Ik=10mA, R1=10KΩ, R2=∞ TA=Full Temperature
Minimum Cathode Current for Regulation	IkA(min)	-	0.45	1.0	mA	VKA=VREF
Off-State Cathode Current	IkA(off)	-	0.05	1.0	uA	VKA=36V, VREF=0
Dynamic Impedance	Zk	-	0.15	0.5	Ω	VKA=VREF, Ik=1 to 100mA, F≤1.0KHz

Note: Tmin= 0°C, Tmax=+70°C



Functional Block Diagram & Symbol

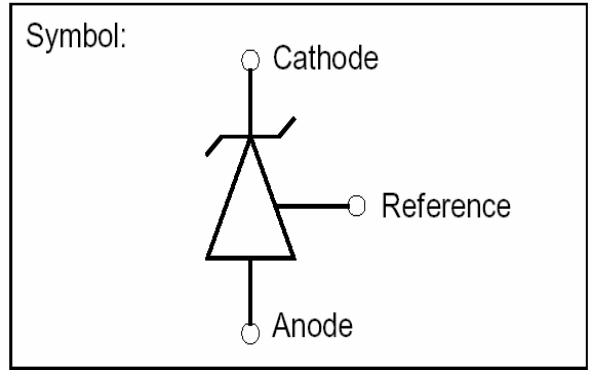
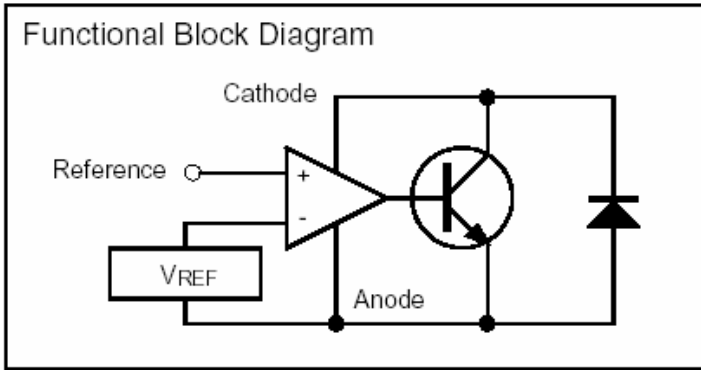

Test Circuits

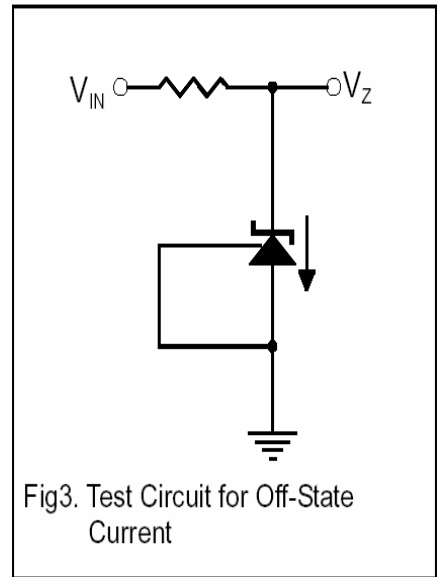
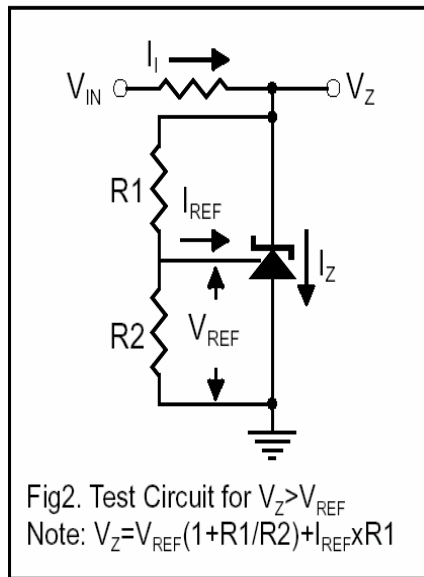
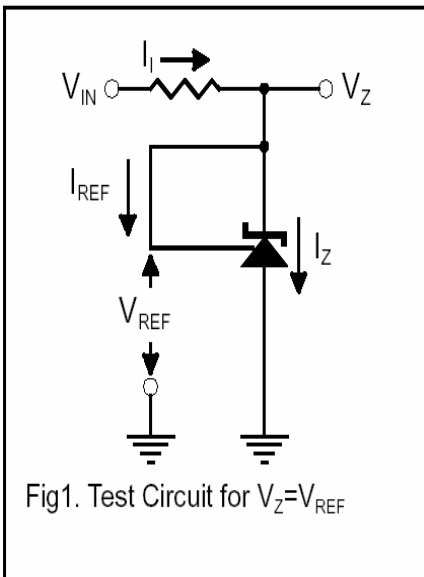

Characteristics Curve

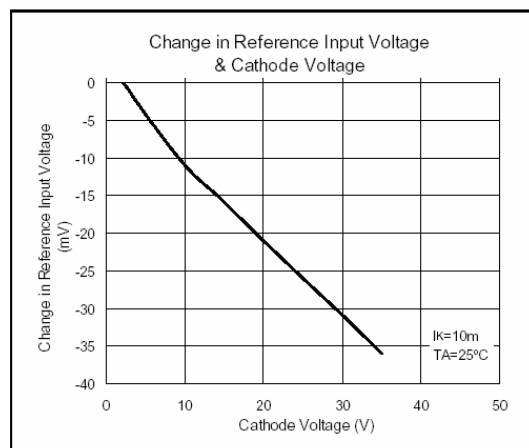
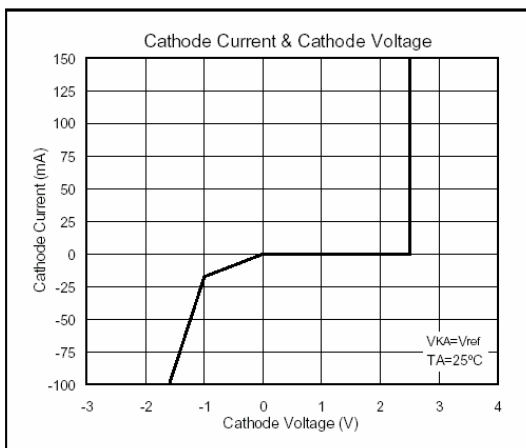

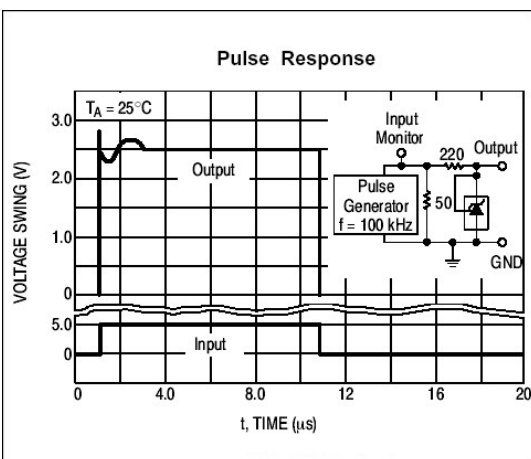
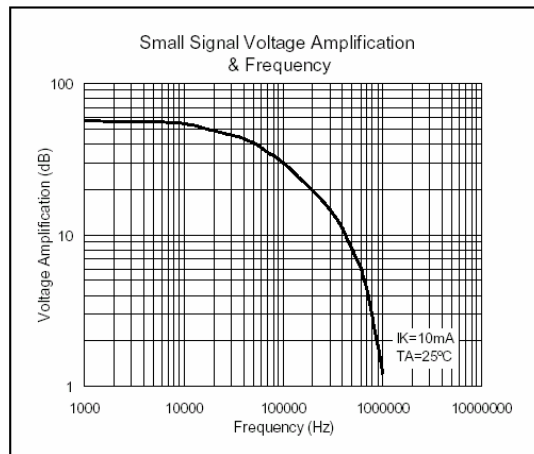
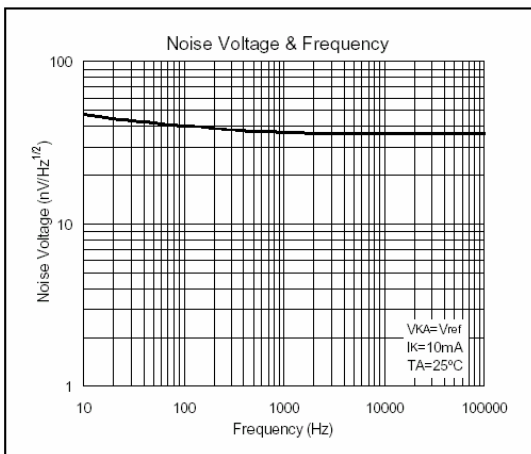
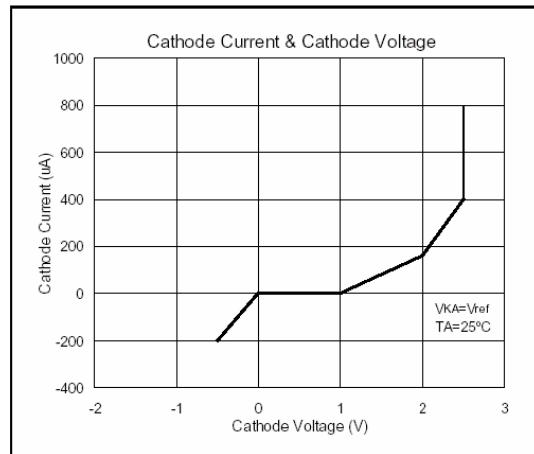
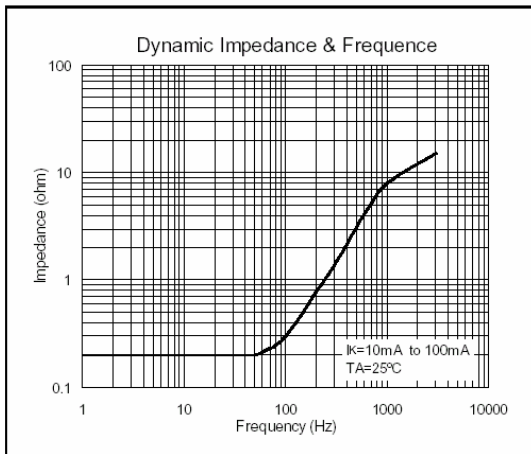

Important Notice:

- All rights are reserved. Reproduction in whole or in part is prohibited without the prior written approval of GTM.
- GTM reserves the right to make changes to its products without notice.
- GTM semiconductor products are not warranted to be suitable for use in life-support Applications, or systems.
- GTM assumes no liability for any consequence of customer product design, infringement of patents, or application assistance.

Head Office And Factory:

- Taiwan:** No. 17-1 Tatung Rd. Fu Kou Hsin-Chu Industrial Park, Hsin-Chu, Taiwan, R. O. C.
- TEL : 886-3-597-7061 FAX : 886-3-597-9220, 597-0785
- China:** (201203) No.255, Jang-Jiang Tsai-Lueng RD. , Pu-Dung-Hsin District, Shang-Hai City, China
- TEL : 86-21-5895-7671 ~ 4 FAX : 86-21-38950165