



High-Efficiency White LED Charge Pump

Features

- Input Range : 2.7V to 5V
- Quiescent Current: 90µA
- Regulated 5V ±4% output
- 5V Output Current
 - 90mA with $V_{IN} \geq 3.0V$
 - 40mA with $V_{IN} \geq 2.7V$
- High Frequency 1MHz operation
- Shutdown mode draws less than 1µA
- Shot-circuit/over-temperature protection
- SOT-23-6 and TSOT-23-6 package

Applications

- Portable Communication Devices
- Cellular Phones
- PDA
- Handheld Electronics
- Digital Cameras
- LED/Display Back Light Driver
- LED for Camera Flash

General Description

The G5910 Charge-Pump is a switched-capacitor voltage converter that delivers a regulated output. The external inductor is not required for operation. Using small capacitors, the G5910 can deliver up to 90mA (@ $V_{IN}=3V$) to the voltage-regulated output. The G5910 features high efficiency over a large portion of its load range making this device ideal for battery-powered applications. The combination of few external components and small package size keeps the total converter board area to a minimum in space-restricted applications. The G5910 contains a thermal management circuit to protect the device under continuous output short circuit conditions.

The G5910 is available in a surface mount SOT-23-6 and TSOT-23-6 package.

Ordering Information

| ORDER NUMBER | MARKING | TEMP. RANGE | PACKAGE (Pb free) |
|--------------|---------|---------------|-------------------|
| G5910-45TBU | 5911x | -40°C to 85°C | SOT-23-6 |
| G5910-50TBU | 5910x | -40°C to 85°C | SOT-23-6 |
| G5910-45TPU | 5911x | -40°C to 85°C | TSOT-23-6 |
| G5910-50TPU | 5910x | -40°C to 85°C | TSOT-23-6 |

Note: TB : SOT-23-6 TP:TSOT-23-6
U: Tape & Reel

Pin Configuration

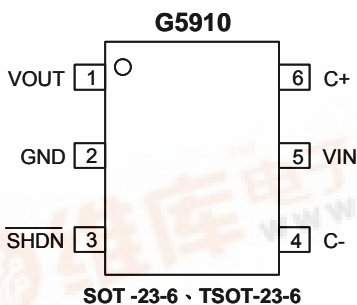

Typical Application Circuit

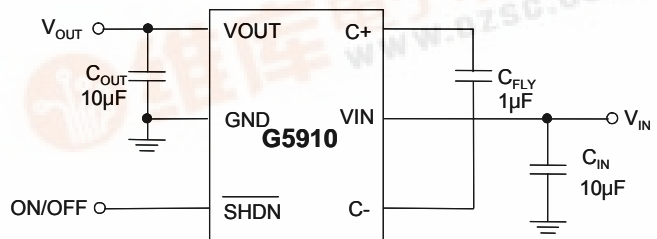

CIN, COUT: TAIYO YUDEN, JMK212BJ106KG
CFLY: TAIYO YUDEN, EMK212JB105KG

**Absolute Maximum Ratings**

V_{IN} to GND. -0.3V to 6V
 V_{OUT} to GND. -0.3V to 6V
 \overline{SHDN} to GND -0.3V to 6V
 CP- to GND -0.3V to $V_{IN}+0.3V$
 Output to GND Short-Circuit Duration. Indefinites

Operating Temperature Range -40°C to 85°C
 Junction Temperature. 150°C
 ESD Rating1 HBM 2000V
 Reflow Temperature (soldering, 10sec) 260°C

Note 1 : Human body model is a 100pF capacitor discharged through a 1.5kΩ resistor into each pin.

Electrical Characteristics

$V_{CC} = V_{\overline{SHDN}} = 3V$, $T_A = 25^\circ C$, $C_{FLY} = 1\mu F$, $C_{IN} = 10\mu F$, $C_{OUT} = 10\mu F$, unless otherwise noted.

| DESCRIPTION | SYMBOL | CONDITION | MIN | TYP | MAX | UNIT | |
|--|--------------|--|---|------|-----------|-------------------|---|
| Input Voltage | V_{IN} | $V_{OUT} = 5.0V$ | 2.7 | --- | V_{OUT} | V | |
| No Switching supply Current | I_Q | $2.7V < V_{IN} < 5V$, $I_{OUT} = 0mA$, $\overline{SHDN} = V_{IN}$, $V_{OUT} = 5.5V$ | --- | 90 | 140 | μA | |
| Output Voltage | V_{OUT} | G5910-50 | $2.7V < V_{IN} < 5V$, $I_{OUT} \leq 40mA$ | 4.8 | 5 | 5.2 | V |
| | | | $3.0V < V_{IN} < 5V$, $I_{OUT} \leq 90mA$ | | | | |
| | | G5910-45 | $2.7V < V_{IN} < 5V$, $I_{OUT} \leq 50mA$ | 4.32 | 4.5 | 4.68 | |
| | | | $3.0V < V_{IN} < 5V$, $I_{OUT} \leq 100mA$ | | | | |
| Shutdown Supply Current | I_{SHDN} | $2.7V < V_{IN} < 5V$, $I_{OUT} = 0mA$, $V_{\overline{SHDN}} = 0$ | --- | --- | 1 | μA | |
| Ripple Voltage | V_{RIPPLE} | $V_{IN} = 3V$, $I_{OUT} = 50mA$ | --- | 25 | --- | mV _{P-P} | |
| | | $V_{IN} = 3V$, $I_{OUT} = 90mA$ | --- | 20 | --- | | |
| Efficiency | η | $V_{IN} = 2.7V$, $I_{OUT} = 40mA$ | --- | 88 | --- | % | |
| | | $V_{IN} = 3V$, $I_{OUT} = 90mA$ | --- | 80 | --- | | |
| Frequency | F_{OSC} | Oscillator Free Running | 0.7 | 1 | 1.3 | MHz | |
| \overline{SHDN} Input Threshold High | V_{IH} | | 1.4 | --- | --- | V | |
| \overline{SHDN} Input Threshold Low | V_{IL} | | --- | --- | 0.3 | V | |
| V_{OUT} Turn-on time | t_{ON} | $V_{IN} = 3V$, $I_{OUT} = 0mA$ | --- | 0.22 | --- | ms | |
| Short-circuit current | I_{SC} | $V_{IN} = 3V$, $V_{OUT} = GND$, $\overline{SHDN} = 3V$ | --- | 340 | --- | mA | |
| Thermal Shutdown Temperature | T_{SD} | | --- | 150 | --- | °C | |
| Thermal Shutdown Hysteresis | | | --- | 30 | --- | °C | |



Typical Performance Characteristics

($V_{IN}=3V$, $C_{IN}=C_{OUT}=10\mu F$, $C_{FLY}=1\mu F$, $T_A=25^\circ C$, unless otherwise noted.)

Startup Time with 50mA Load

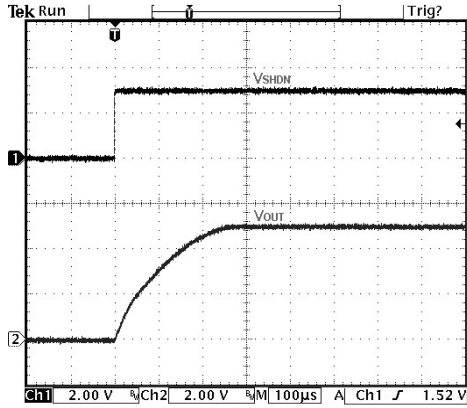

Startup Time with 90mA Load

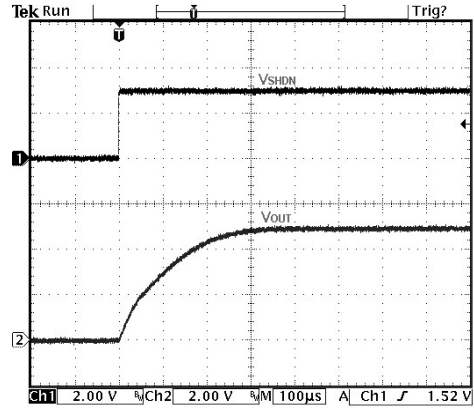

Output Ripple with $I_{OUT}=50mA$

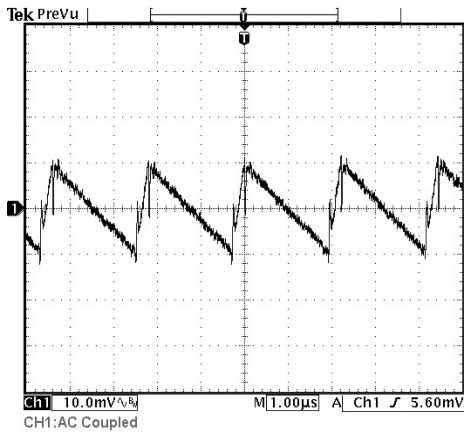

Output Ripple with $I_{OUT}=90mA$

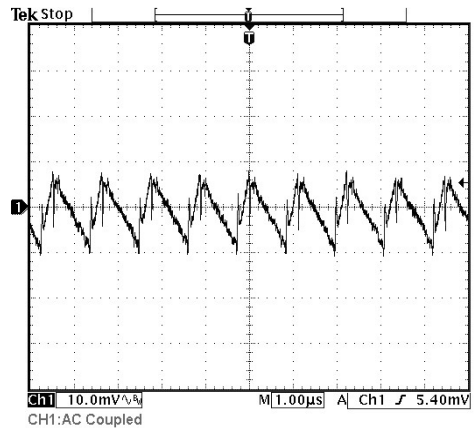

Load Transient for 50mA

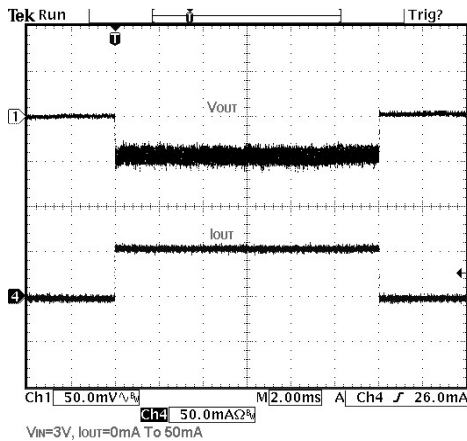

Load Transient for 90mA

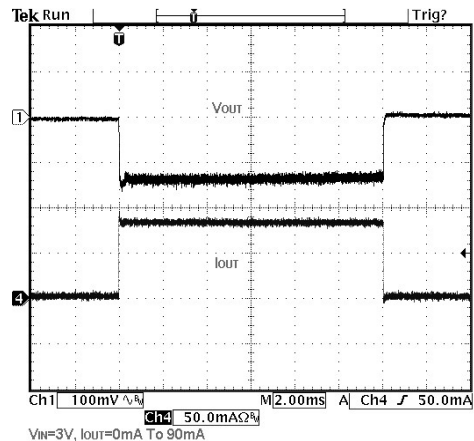



Typical Performance Characteristics (continued)

Output Voltage vs Output Current

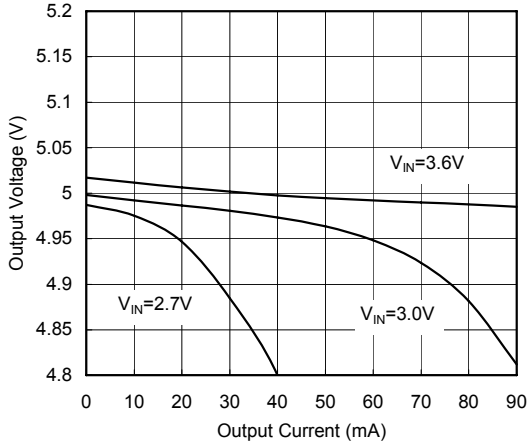

Output Voltage vs Supply Voltage

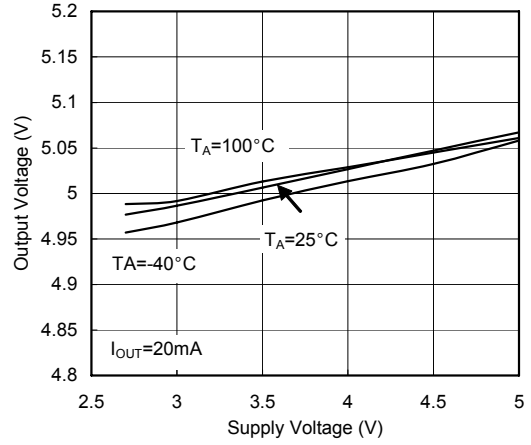

Output Voltage vs Temperature

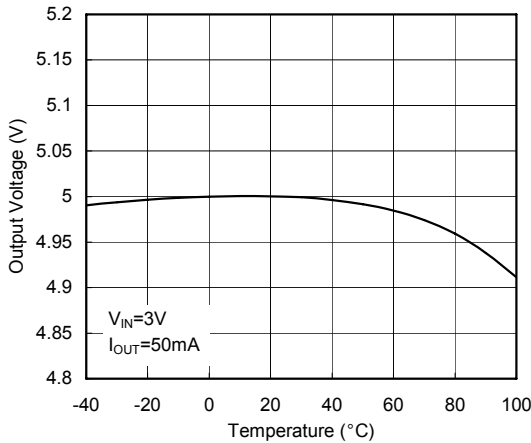

Supply Current vs Supply Voltage

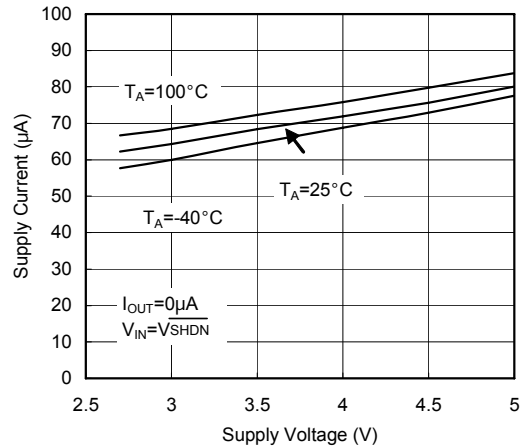

Supply Current vs Temperature

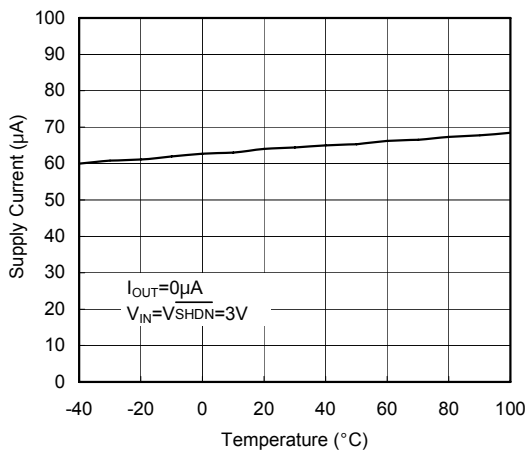

Supply Current vs SHDN Voltage

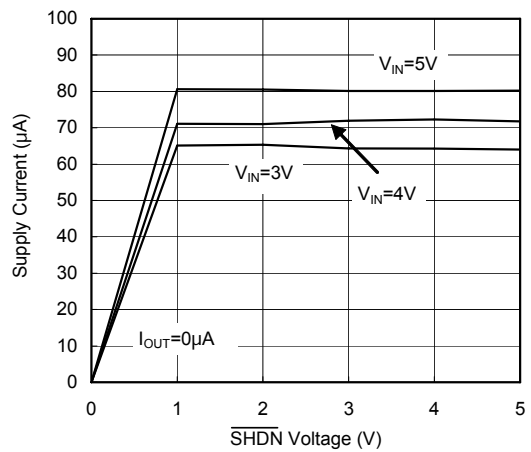



Typical Performance Characteristics (continued)

Frequency vs Supply Voltage

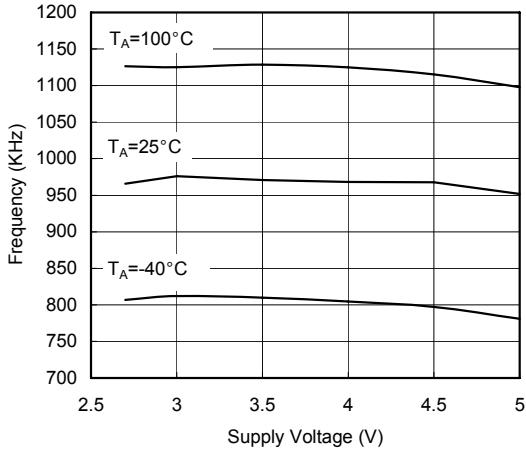

Frequency vs. Temperature

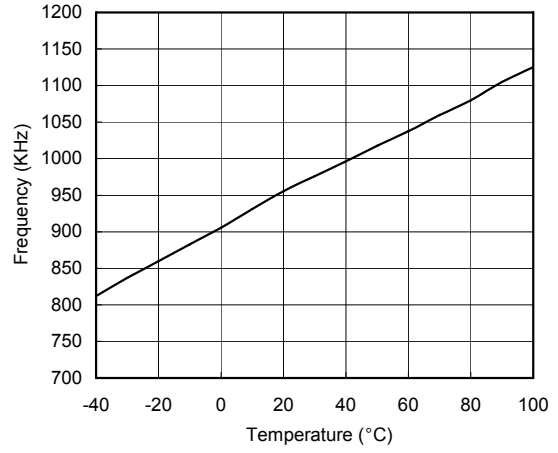

V_{IH} vs Supply Voltage

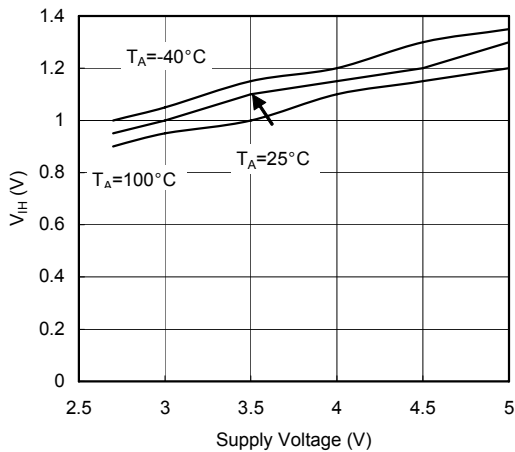

V_{IL} vs Supply Voltage

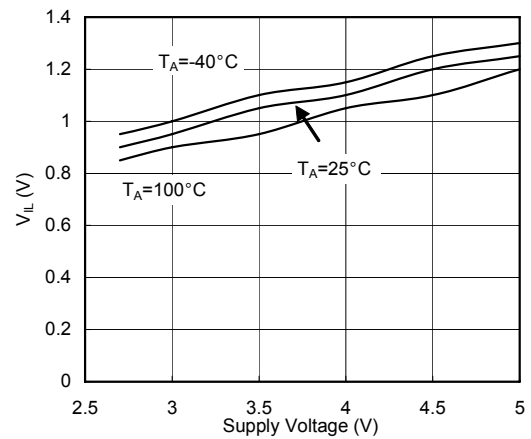

Efficiency vs Input Voltage

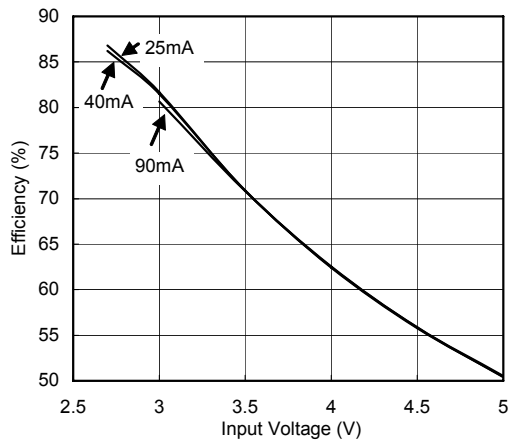

Efficiency vs Load Current

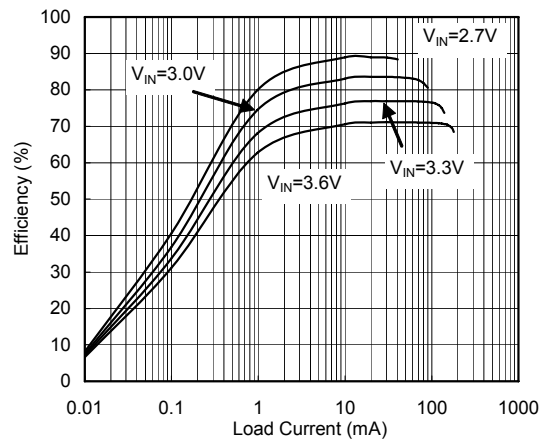



Typical Performance Characteristics (continued)

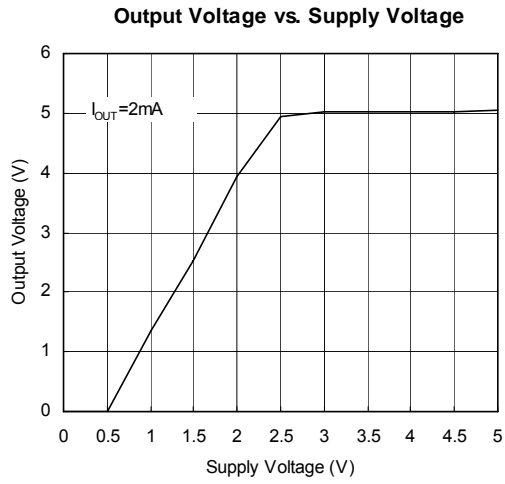

Recommended Minimum Footprint

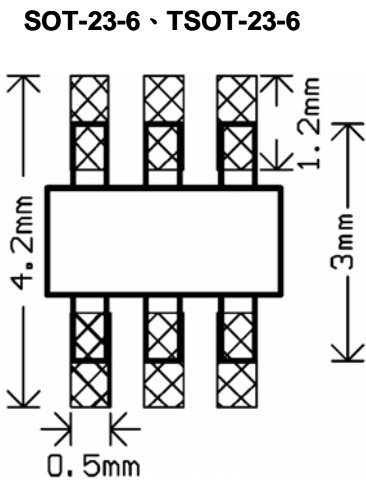

**Pin Descriptions**

| PIN | NAME | FUNCTION |
|-----|------|---|
| 1 | VOUT | Regulated output pin. Bypass this pin to ground with at least 6.8 μ F low ESR capacitor |
| 2 | GND | Ground connection |
| 3 | SHDN | Shutdown input. Active low signal disables the converter. |
| 4 | C- | Flying capacitor negative terminal |
| 5 | VIN | Input supply pin. Bypass this pin to ground with at least 6.8 μ F low ESR capacitor |
| 6 | C+ | Flying capacitor positive terminal |

Detailed Description

The G5910 uses a switched capacitor charge pump to boost an input voltage to a regulated output voltage. Through an internal resistor divider network the output regulation is achieved by sensing the charge pump output voltage. When the divided output drops below a preset trip point that controlled by an internal comparator a switched doubling circuit is enabled. The charge pump switch cycling enables four internal switches at two non-overlapping phases. During the first phase, switches S1 and S4 are switched on (short) and switch S2 and S3 are off (open). The flying capacitor C_{FLY} is charged to a level approximately equal to input voltage V_{IN} . On the second phase, switches S1 and S4 are turned off (open), S2 and S3 are turned on (short). During the first phase the low side of the flying capacitor C_{FLY} is connected to GND. During the second phase, the flying capacitor C_{FLY} is switched so that the low side is connected to V_{IN} . The voltage at the high side of the flying capacitor C_{FLY} is bootstrapped to $2 \times V_{IN}$ and is connected to output through a switch. For each cycle phase, charge from input node V_{IN} is transported from a lower voltage to a higher voltage. This cycle repeats itself until the output node voltage is high

enough to exceed the preset input threshold of the control comparator. When the output voltage exceeds the internal trip point voltage level, the switching cycle stops and the charge pump circuit is placed in an idle state. The closed loop feed back system containing the voltage sense circuit and control comparator allows the G5910 to provide a regulated output voltage and output load current. An integrated oscillator within the control circuit block creates the switching signal that drives the charge pump. The free running charge pump switching frequency is approximately 1MHz. The G5910 has complete output short circuit and thermal protection to safeguard the device under extreme operating conditions. When output voltage is short to ground, the switches S1, S4, and S3 are turned on with limited current of 220mA. After the short circuit condition has been released and output voltage rises above a threshold voltage, the G5910 will go into normal operation mode. An internal thermal protection circuit senses die temperature and will shut down the device if the internal junction temperature exceeds approximately 150°C. The charge pump will remain disabling until the fault condition is relieved.

Block Diagram

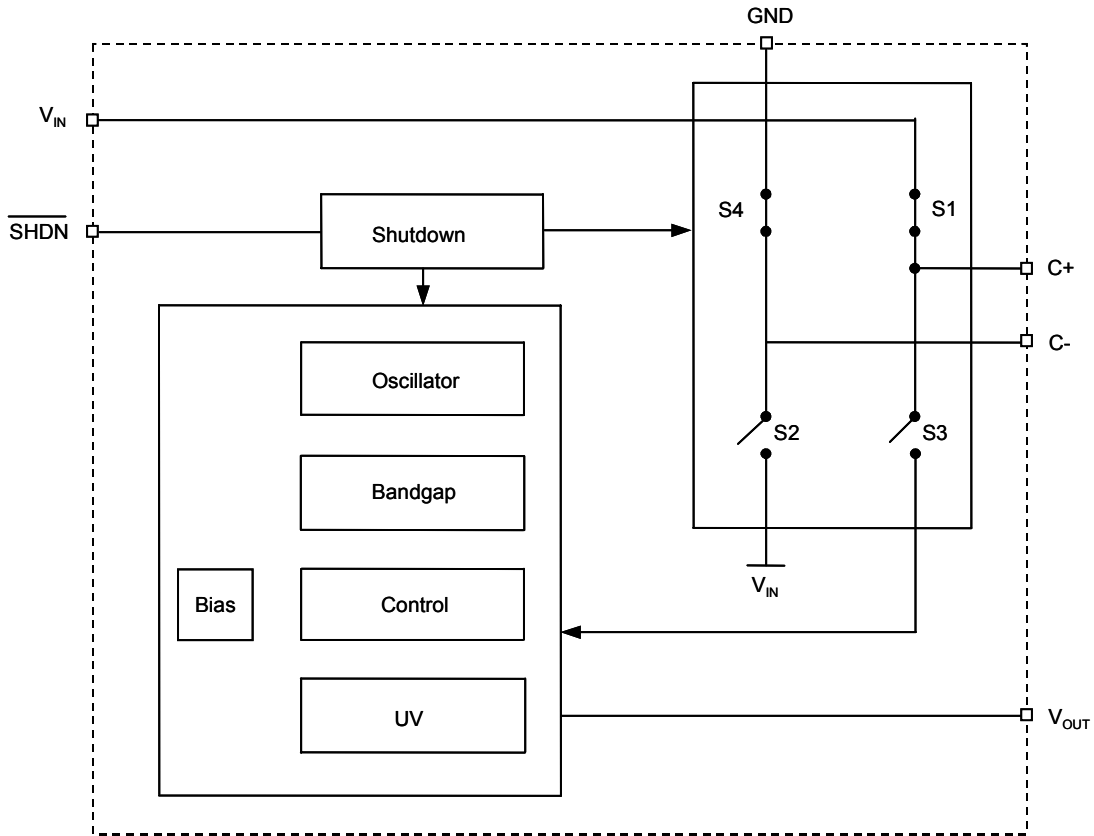

Layout Considerations

High charge pump switching frequencies and large peak transient currents mandate careful printed circuit board layout. As a general rule for charge pump boost converters, all external capacitors should be located as close as possible to the device package with minimum length trace connections. Maximize the ground plane around the G5910 charge pump and make sure all external

capacitors are connected to the immediate ground plane. A local component side ground plane is recommended. If this is not possible due the layout design limitations, assure good ground connections by the use of large or multiple pcb via's. Refer to the following G5910 evaluation board for an example of good charge pump layout design.

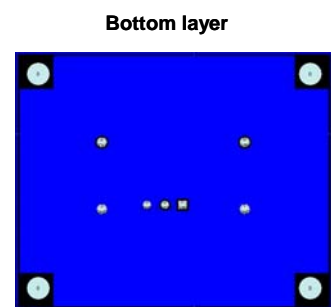
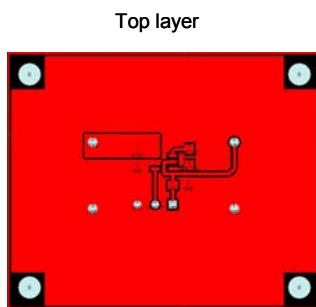
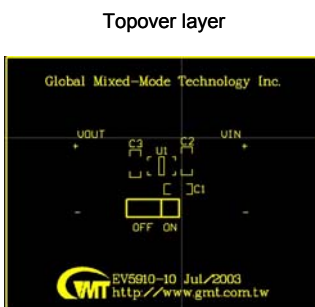



Package Information

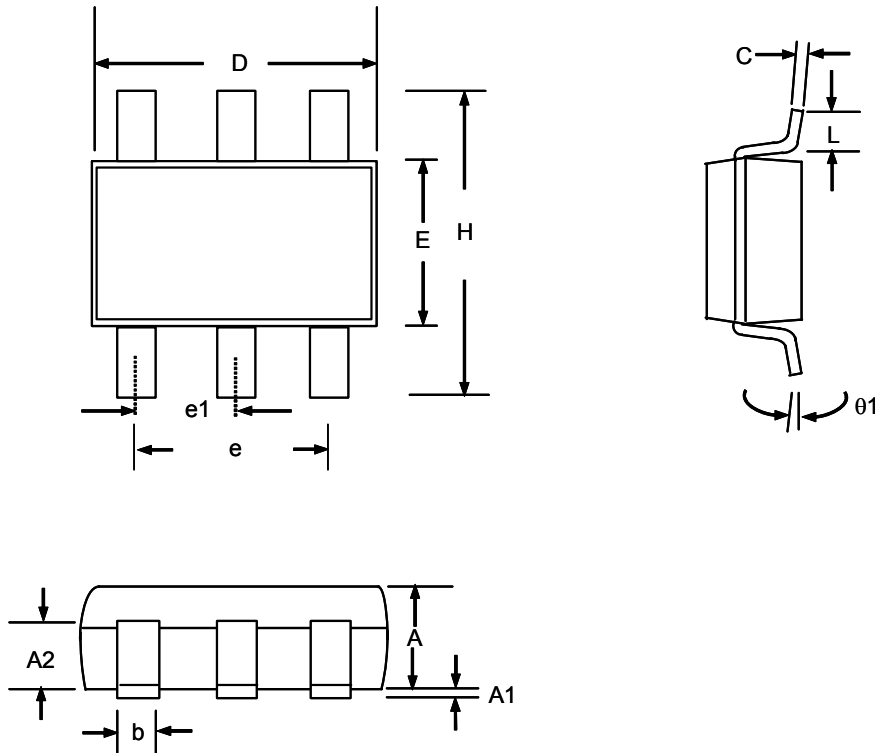

SOT-23-6 (TB) Package

Note:

1. Package body sizes exclude mold flash protrusions or gate burrs
2. Tolerance ± 0.1000 mm (4mil) unless otherwise specified
3. Coplanarity: 0.1000mm
4. Dimension L is measured in gage plane

| SYMBOL | DIMENSION IN MM | | | DIMENSION IN INCH | | |
|------------|-----------------|-----------|-------|-------------------|------------|-------|
| | MIN. | NOM. | MAX. | MIN. | NOM. | MAX. |
| A | 1.00 | 1.10 | 1.30 | 0.039 | 0.043 | 0.051 |
| A1 | 0.00 | ----- | 0.10 | 0.000 | ----- | 0.004 |
| A2 | 0.70 | 0.80 | 0.90 | 0.028 | 0.031 | 0.035 |
| b | 0.35 | 0.40 | 0.50 | 0.014 | 0.016 | 0.020 |
| C | 0.10 | 0.15 | 0.25 | 0.004 | 0.006 | 0.010 |
| D | 2.70 | 2.90 | 3.10 | 0.106 | 0.114 | 0.122 |
| E | 1.40 | 1.60 | 1.80 | 0.055 | 0.063 | 0.071 |
| e | ----- | 1.90(TYP) | ----- | ----- | 0.075(TYP) | ----- |
| H | 2.60 | 2.80 | 3.00 | 0.102 | 0.110 | 0.118 |
| L | 0.37 | ----- | ----- | 0.015 | ----- | ----- |
| $\theta 1$ | 1° | 5° | 9° | 1° | 5° | 9° |

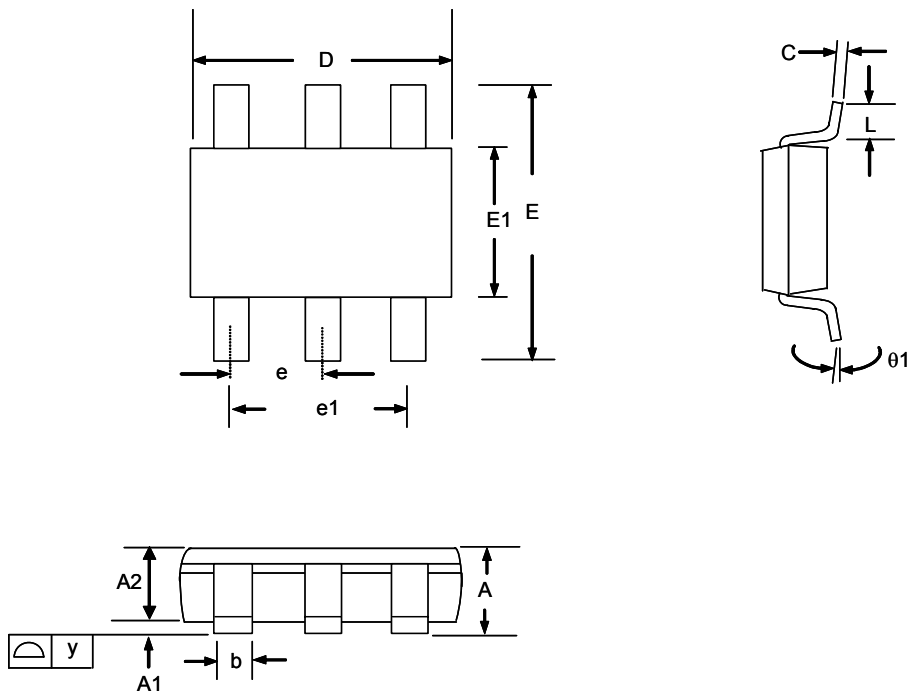

TSOT-23-6 (TP) Package

Note:

1. Dimension D does not include mold flash, protrusions or gate burrs. Mold flash, protrusions or gate burrs shall not exceed 0.1mm PER end. Dimension E1 does not include interlead flash or protrusion. Interlead flash or protrusion shall not exceed 0.15mm PER side.
2. The package top may be smaller than the package bottom. Dimensions D and E1 are determined at the outermost extremes of the plastic body exclusive of mold flash, tie bar burrs, gate burrs and interlead flash, but including any mismatch between the top and bottom of the plastic body.

| SYMBOL | DIMENSION IN MM | | | DIMENSION IN INCH | | |
|--------|-----------------|-------|-------|-------------------|-------|-------|
| | MIN. | NOM. | MAX. | MIN. | NOM. | MAX. |
| A | 0.75 | ----- | 0.90 | 0.030 | ----- | 0.035 |
| A1 | 0.00 | ----- | 0.10 | 0.000 | ----- | 0.004 |
| A2 | 0.70 | 0.75 | 0.80 | 0.028 | 0.030 | 0.031 |
| b | 0.35 | ----- | 0.51 | 0.014 | ----- | 0.020 |
| C | 0.10 | ----- | 0.25 | 0.004 | ----- | 0.010 |
| D | 2.80 | 2.90 | 3.00 | 0.110 | 0.114 | 0.118 |
| E | 2.60 | 2.80 | 3.00 | 0.102 | 0.110 | 0.118 |
| E1 | 1.50 | 1.60 | 1.70 | 0.059 | 0.063 | 0.067 |
| e | 0.95 BSC | | | 0.0374 BSC | | |
| e1 | 1.90 BSC | | | 0.0748 BSC | | |
| L | 0.37 | ----- | ----- | 0.015 | ----- | ----- |
| y | ----- | ----- | 0.10 | ----- | ----- | 0.004 |
| θ 1 | 0° | ----- | 8° | 0° | ----- | 8° |

Taping Specification

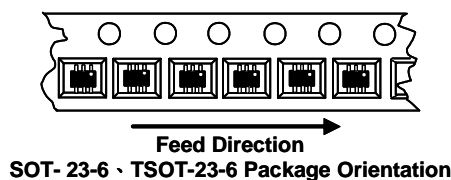

| PACKAGE | Q'TY/REEL |
|-----------|-----------|
| SOT-23-6 | 3,000 ea |
| TSOT-23-6 | 3,000 ea |