

HA1199P

Advance Information

AM SUBSYSTEM FOR CAR RADIO

The HA1199P is a complete one-chip radio subsystem for car radio applications. Automatic dynamic range magnitude control at the RF stage provides good high input signal-handling characteristics (THD = 1% typ at 130 dB μ).

- High AGC FOM — 63 dB Typ
- Good Usable Sensitivity — 23 dB μ Typ
- Low Distortion — 0.4% Typ at 74 dB μ
- Supply Voltage Range — 10.8 to 15.6 Volts

AM RADIO SUBSYSTEM

MONOLITHIC SILICON
INTEGRATED CIRCUIT

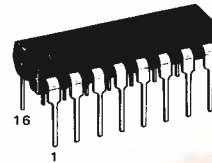

P SUFFIX
PLASTIC PACKAGE
CASE 648

FIGURE 1 — TEST CIRCUIT

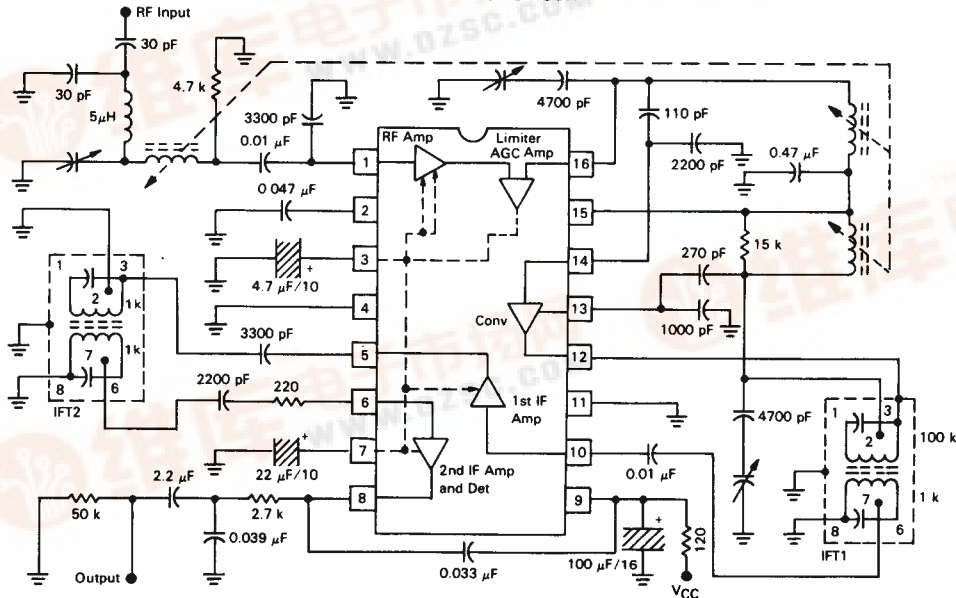

PIN CONNECTIONS

- | | | | |
|----------------------|-----------------------------|-----------------------------|------------------------|
| 1 RF Amplifier Input | 5 First IF Amplifier Output | 9 VCC | 13 Lo Input |
| 2 RF Bypass | 6 Second IF Amplifier Input | 10 First IF Amplifier Input | 14 Converter Input |
| 3 AGC Bypass | 7 AGC Bypass | 11 Gnd | 15 VCC' |
| 4 Gnd | 8 Detector Output | 12 Converter Output | 16 RF Amplifier Output |



HA1199P

MAXIMUM RATINGS

Rating	Value	Unit
Power Supply Voltage	16	Volts
Junction Temperature	150	°C
Operating Temperature Range (Ambient)	-30 to +70	°C
Storage Temperature Range	-65 to +150	°C

ELECTRICAL CHARACTERISTICS (V_{CC} = 13.2 V, f_c = 1.0 MHz, f_{mod} = 400 Hz, T_A = 25°C unless otherwise noted)

Characteristic	Min	Typ	Max	Unit
Drain Current at Zero Signal	—	15	—	mA
Signal-to-Noise Ratio Input = 34 dB _μ , 30% Modulation	25.5	30	—	dB
AGC FOM Test @ 10 dB Output Down, 30% Modulation 1) Output @ 74 dB _μ Input 2) Output @ 86 dB _μ Input	— 51	57 63	— —	dB
Detector Output Input = 74 dB _μ , 30% Modulation	80	120	157	mV
Distortion Input = 114 dB _μ , 30% Modulation	—	0.4	5.0	%
Sensitivity Input @ S/N = 20 dB, 30% Modulation	—	23	—	dB _μ

SPECIFICATION OF THE IFTs



	Q0	Number of Turns				C1 (pF)	C2 (pF)	Tuned Frequency (kHz)
		1-2	2-3	6-7	7-8			
First IFT	70	66	220	260	26	180	180	262.5
Second IFT	70	271	23	271	23	180	180	262.5