

# HA16671MP, HA16672MP

## Voice Coil Motor (VCM) Servo Controller

### Description

The HA16671MP and HA16672MP are VCM servo controllers for hard disk head positioning. Three chips can make up a control system for the HA13447 VCM driver: the HA16670MP for position signal generation, and the HA16671MP and HA16672MP servo controllers.

The HA16671MP is composed of a speed detection circuit, current integrating circuit, phase compensator, op amp filter, etc.

The HA16672MP, on the other hand, contains an 8-bit DAC, and can output target speed, target acceleration, and external force compensation values based on data from a microprocessor.

### Functions

- Position signal differentiation
- Current integration
- 1/4 track detection
- Fine track detection
- 8-bit DAC
- Sample and hold circuit
- Op amp for filter design

### Features

- Two power supply design (+5 V, +12 V)
- Compact surface-mount package (SMP)
- Feed forward compensation for low-error speed control
- Compensation based on acceleration and external force data can be added to the speed control loop
- Digital signals can be/directly linked to a microprocessor
- External op amps not needed

### Ordering Information

Type No.	Package
HA16671MP, HA16672MP	MP-44

HA16671MP, HA16672MP

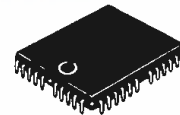

(MP-44)

### Pin Assignments

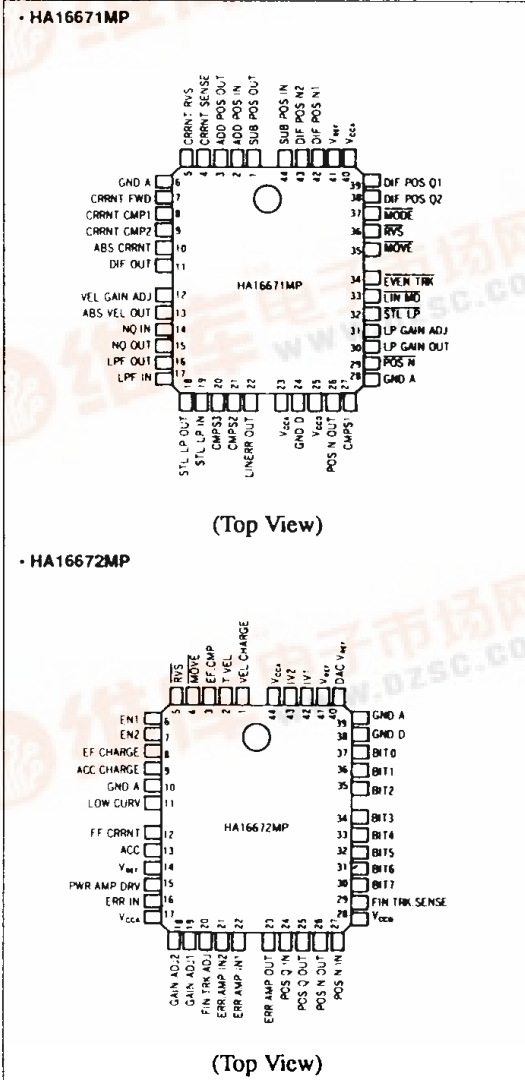

# HA16671MP, HA16672MP

## Block Diagram

HA16671MP

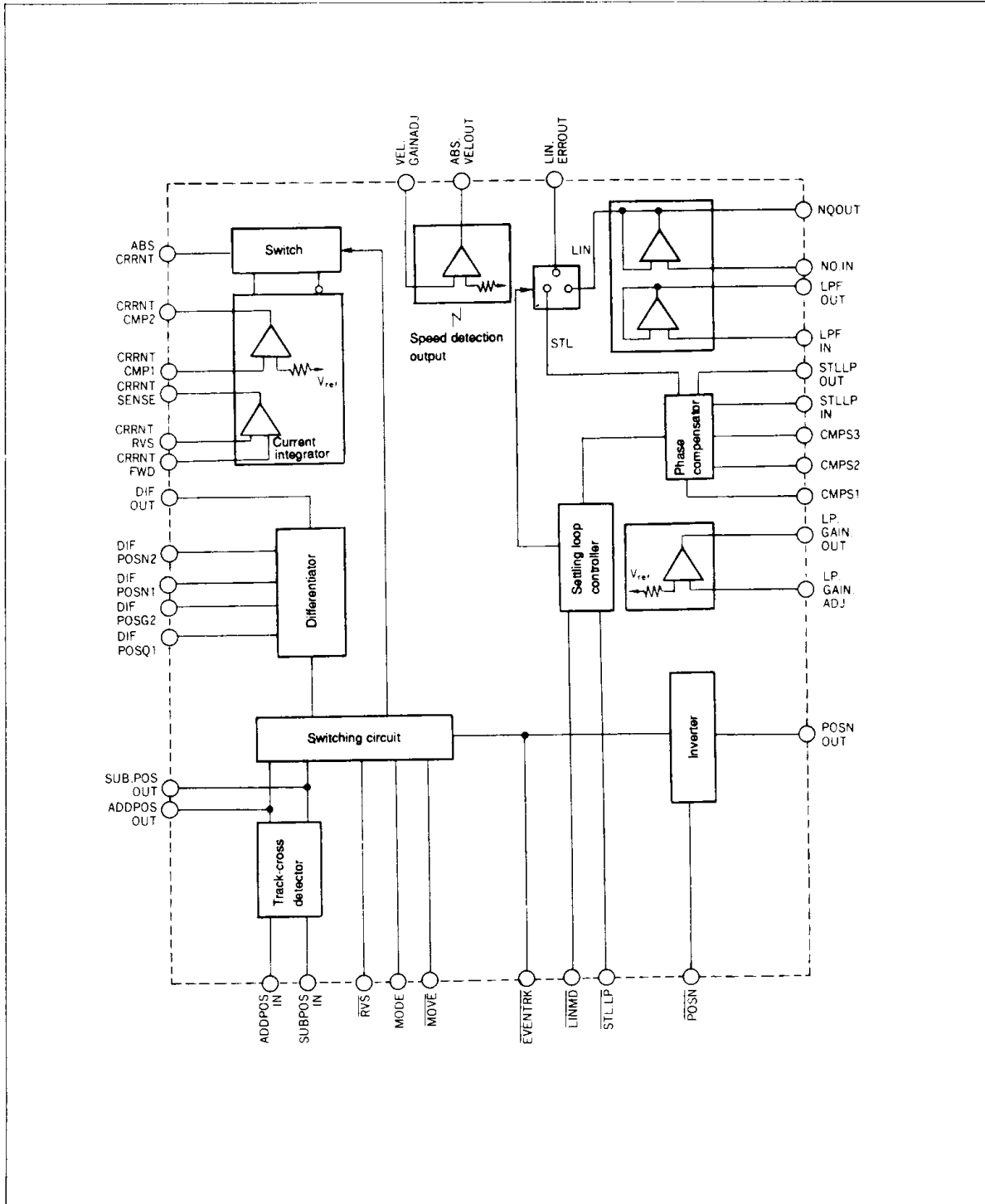

HA16672MP

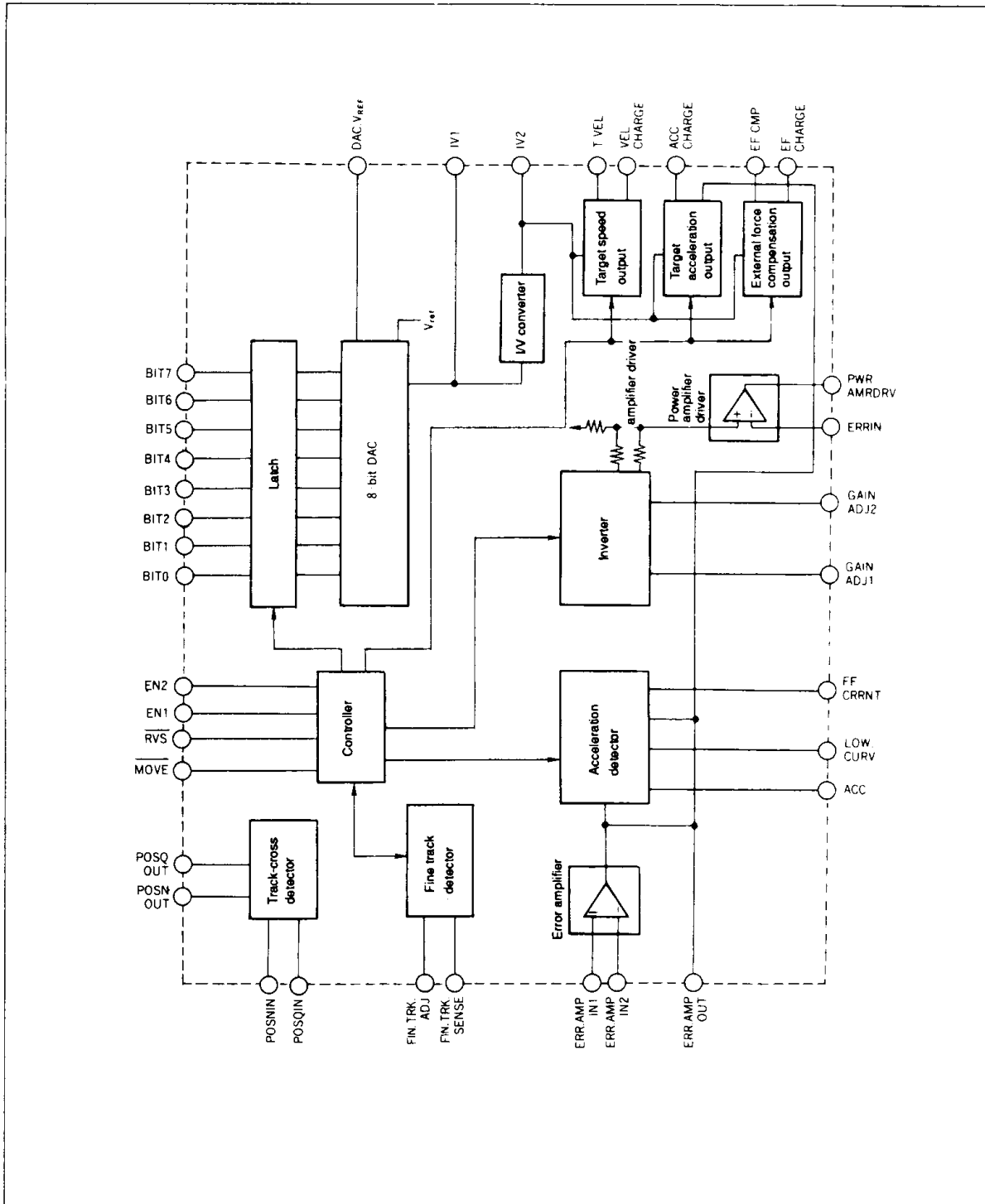

# HA16671MP, HA16672MP

## Pin Descriptions

### HA16671MP

Type	Pin No.	Name	Function	
Power supply	23, 40	V <sub>CCA</sub>	+12 V power supply (analog)	
	25	V <sub>CCD</sub>	+5 V power supply (logic)	
	6,28	G <sub>ND</sub> A	Analog GND	
	24	G <sub>ND</sub> D	Logic GND	
Input	41	V <sub>REF</sub>	Op amp reference voltage	
	37	MODE	Position signal differentiation mode select Low: 2-phase servo mode High: 1-phase servo mode	
	35	MOVE	Position signal differentiation select Low: On High: Off	
	36	RVS	Position signal differentiation and current integrating inverter	
	33	LIN MD	Positioning phase compensation control select Low: On High: Off	
	32	STL LP	Settling compensation control	
	34	EVEN TRK	Positioning signal inverter	
	2	ADD POS IN	Comparator signals for the position signal differentiation circuit	
	44	SUB POS IN		
	29	POS N	Positioning signal converter signal circuit	
	31	LP GAIN ADJ	Op amp input for positioning signal gain adjustment	
	17	LPF IN	Op amp input for positioning compensation active filter	
	14	NQ IN		
	39	DIF POS Q1	Op amp input for positioning signal differentiation	
	42	DIF POS N1		
	27	CMPS1	Op amp input for positioning signal phase compensation	
	7	CRRNT FWD	Op amp input for voice coil motor drive current detection	
	5	CRRNT RVS		
	8	CRRNT CMP1	Op amp input for current integration	
	12	VELGAIN ADJ	Op amp input for speed signal detection	
	Outputs	1	SUB POS OUT	Comparator signals for the position signal differentiation circuit
		3	ADD POS OUT	
		26	POS N OUT	Positioning signal inverter
		30	LP GAIN OUT	Op amp output for positioning signal gain adjustment
		18	STL LP OUT	Op amp output for positioning phase compensation
		16	LPF OUT	Op amp output for positioning compensation active filter
		15	NQ OUT	
11		DIF OUT	Positioning signal differentiation signal	
10		ABS CRRNT	Motor drive current integration signal	
13		ABS VEL OUT	Speed signal output	
22		LINERR OUT	Positioning compensation signal	
External components		21	CMP S2	Positioning integration constant
	20	CMP S3		
	19	STL LP IN	Settling compensation circuit constant	
	38	DIF POS Q2	Position signal differentiation constant	
	43	DIF POS N2		
9	CRRNT CMP2	Motor drive current integration constant		

# HA16671MP, HA16672MP

## HA16672MP

Type	Pin No.	Name	Function	
Power supply	17, 44	VCCA	+12 V power supply (analog)	
	28	VCCD	+5 V power supply (logic)	
	10, 39	GND A	Analog GND	
	38	GND D	Logic GND	
Inputs	14, 41	VREF	Reference voltage	
	4	MOVE	DAC latch and analog control signals	
	5	RVS	Analog switch control signal; High: FWD; Low: RVS	
	37–30	BIT0–BIT7	DAC inputs; BIT0: LSB; BIT7: MSB	
	6	EN1	Sample and hold control signal	
	7	EN2		
				—    VEL    ACC    EF
				ENT1   0    1    0    1
				ENT2   0    0    1    1
Outputs	27	POS N IN	Microprocessor comparator (+) signal	
	24	POS Q IN	Microprocessor comparator (+) signal	
	22	ERR AMP IN1	Non-inverting op amp input for speed error signal generation	
	21	ERR AMP IN2	Inverting op amp input for speed error signal generation	
	19	GAIN ADJ1	Inverting op amp input for gain control	
	16	ERR IN	Inverting op amp input for VCM control signal generation	
	40	DAC VREF	DAC reference current	
	20	FIN.TRK.ADJ	Fine track width voltage level	
	29	FIN.TRK.SENSE	Comparator output for microprocessor control and seek control	
	23	ERR.AMP.OUT	Op amp output for speed error signal	
	2	T.VEL	Target speed signal	
	3	EF.CMP	External force compensation signal	
	11	LOW.CURV	Acceleration signal	
	12	FF.CRRNT	Acceleration signal	
	13	ACC	Acceleration signal (for monitor)	
18	GAIN ADJ2	Op amp output for gain control		
15	PWR.AMP.DRV	Op amp output for VCM control		
26	POS N OUT	Comparator output for microprocessor control		
25	POS Q OUT	Comparator output for microprocessor control		
External components	1	VEL.CHARGE	Sample and hold capacitors	
	9	ACC.CHARGE		
	8	EF.CHARGE		

## Principles of Operation

**Track Following:** Figure 1 shows the feedback loop for tracking. The loop holds the position error at zero by using a quadratic lowpass filter, notch filter, and lead/lag phase compensation to eliminate resonance from VCM mechanical vibrations.

**Settling Control:** Vibration is greatest when the VCM moves from seek to tracking. To reach a stable, stationary

state as quickly as possible, the IC increases the bandwidth by switching a filter (shown with dotted lines in figure 1) into the control loop.

**Speed Detection and Seek:** The actual speed is determined using the bandwidth division technique, which involves differentiating the position signal and integrating the current. Seek operation is carried out according to a speed profile which minimizes head movement. Figure 2 shows the speed control loop.

# HA16671MP, HA16672MP

**Track Crossing Detection:** From the two position signals POSN and POSQ, four signals ( $N>0$ ,  $Q>0$ ,  $N+Q>0$ ,  $-N+Q>0$ , corresponding to POSN OUT, POSQ OUT, ADD POS OUT, SUB POS OUT) are created and output.

**DAC and Sample and Hold:** Target speed, acceleration, and external force compensation data is input from the microprocessor as a time series, and converted into an analog signal. These signals are used as the target speed, target acceleration, and external force compensation values.

**End Acceleration Detection:** End acceleration detection reduces the variance of actual speed by adding acceleration data to the control loop.

**Fine Track Detection:** Whether or not the head is on-track is detected by the position signal input into a window comparator. The on-track window can be adjusted externally.

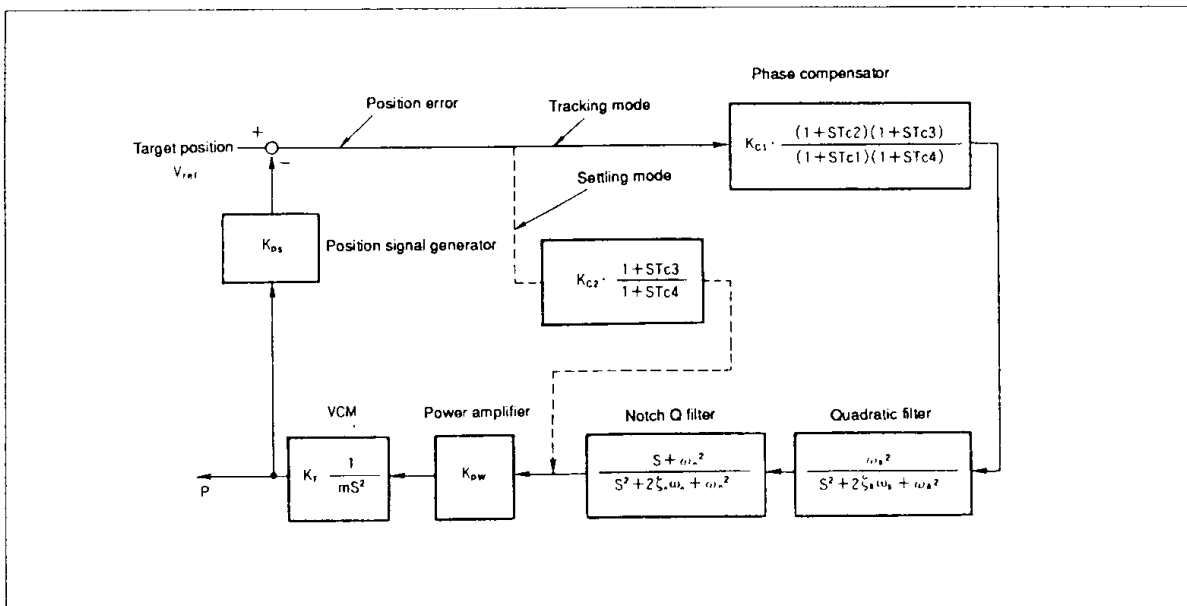

Figure 1 Track Feedback Loop

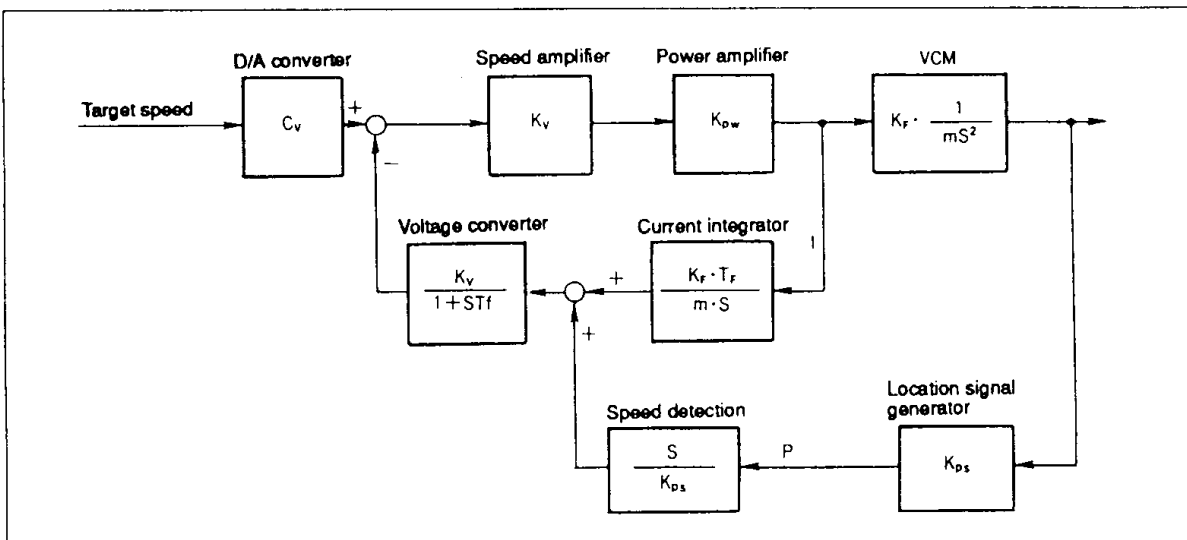

Figure 2 Speed Control Loop

# HA16671MP, HA16672MP

## Absolute Maximum Ratings

### HA16671MP

Parameter	Symbol	Rating	Unit	Pins
Power supply voltage 1	V <sub>CCA</sub>	15.0	V	V <sub>CCA</sub>
Power supply voltage 2	V <sub>CCD</sub>	7.0	V	V <sub>CCD</sub>
Input voltage 1	V <sub>I1</sub>	7.0	V	Note 1
Input voltage 2	V <sub>I2</sub>	V <sub>CCA</sub> - 1.5	V	Note 2
Differential input voltage	V <sub>IN (DIFF)</sub>	V <sub>CCA</sub> - 1.5	V	CURRNT FWD CURRNT RVS
In-phase input voltage	V <sub>CM</sub>	-0.3 to V <sub>CCA</sub> - 1.5	V	CURRNT FWD CURRNT RVS
Input current	I <sub>I</sub>	1.5	mA	Note 3
Output current 1	I <sub>OCL</sub>	3.2	mA	Note 4
Output current 2	I <sub>OCH</sub>	-400	μA	Note 5
Output current 3	I <sub>OAMP</sub>	2.0	mA	Note 6
Operating temperature	T <sub>opr</sub>	0 to +70	°C	
Storage temperature	T <sub>stg</sub>	-55 to +125	°C	

### HA16672MP

Parameter	Symbol	Rating	Unit	Pins
Power supply voltage 1	V <sub>CCA</sub>	15.0	V	V <sub>CCA</sub>
Power supply voltage 2	V <sub>CCD</sub>	7.0	V	V <sub>CCD</sub>
Input voltage 1	V <sub>I1</sub>	7.0	V	Note 7
Input voltage 2	V <sub>I1</sub>	V <sub>CCA</sub> - 1.5	V	Note 8
Input current	I <sub>IDAC</sub>	3.0	mA	DAC V <sub>REF</sub>
Output current 1	I <sub>OCL</sub>	3.2	mA	Note 9
Output current 2	I <sub>OCH</sub>	-400	μA	Note 10
Output current 3	I <sub>OAMP</sub>	±2.0	mA	Note 11
Output current 4	I <sub>ODAC</sub>	3.0	mA	I <sub>y1</sub>
Output current 5	I <sub>OIV</sub>	±12.0	mA	I <sub>y2</sub>
Operating temperature	T <sub>opr</sub>	0 to +70	°C	
Storage temperature	T <sub>stg</sub>	-55 to +125	°C	

The absolute maximum ratings are limiting values, to be applied individually, beyond which the device may be permanently damaged. Functional operation under any of these conditions is not guaranteed. Exposing a circuit to its absolute maximum rating for extended periods of time may affect the device's reliability.

### Notes:

- V<sub>REF</sub>, RVS, MODE, MOVE, EVEN TRK, LIN MD, STLLP
- ADDPOSIN, SUBPOSIN, LPGAINADJ, CMPS1, LPFIN, NQIN, VELGAINADJ, CRRNTCMP1, DIFPOSN1, DIFPOSQ1, POSN, CMPS2, CMPS3, STLLPIN
- POSN, CMPS2, CMPS3, STLLPIN
- When SUBPOSOUT, and ADDPOSOUT outputs are low.
- When SUBPOSOUT and ADDPOSOUT outputs are high.
- LPGAINOUT, STLLPOUT, LPFOUT, NQOUT, ABSVELOUT, CRRNTCMP2, DIFPOSN2, DIFPOSQ2, CURRNTSENSE
- V<sub>REF</sub>, FINTRKADJ, BIT0-BIT7, EN1, EN2, RVS, MOVE
- POSIN, POSQIN, ERRAMPIN1, ERRAMPIN2, GAINADJ1, ERRIN
- When POSNOUT, POSQOUT, and FINTRKSENSE outputs are low.
- When POSNOUT, POSQOUT, and FINTRKSENSE outputs are high.
- ERRAMPOUT, GAINADJ2, PWRAMPDRV, ACC, TVEL, EFCMP, LOWCURV, FFCRRNT

# HA16671MP, HA16672MP

Electrical Characteristics ( $V_{CCA} = 12.0\text{ V}$ ,  $V_{CCD} = V_{REF} = 5.0\text{ V}$ ,  $T_a = 25^\circ\text{C}$ , unless otherwise specified)

Parameter	Symbol	Min	Typ	Max	Unit	Test Conditions	Notes
Power supply	Operating voltage 1	$V_{CCOAP}$	10.8	12.0	13.2	V	1
	Operating voltage 2	$V_{CCDOP}$	4.5	5.0	5.5	V	
	$V_{REF}$ voltage	$V_{REFop}$	4.5	5.0	5.5	V	
	Current consumption	$I_{CCA1}$	—	18.4	23.9	mA	$V_{CCA} = 13.2\text{ V}$ , $V_{CCD} = 5.5\text{ V}$
$I_{CCD1}$		—	3.7	4.1	mA	$V_{CCA} = 13.2\text{ V}$ , $V_{CCD} = 5.5\text{ V}$	
$I_{CCA2}$		—	28	43	mA	$V_{CCA} = 13.2\text{ V}$ , $V_{CCD} = 5.5\text{ V}$	3
$I_{CCD2}$		—	9	15	mA	$V_{CCA} = 13.2\text{ V}$ , $V_{CCD} = 5.5\text{ V}$	
Logic block	Input low voltage	$V_{IL}$	—	—	0.8	V	
	Input high voltage	$V_{IH}$	4.0	—	—	V	
DAC block	Resolution	—	8.0	—	bit		
(HA16672MP)	Phase error	ER	-0.19	0	0.19	% FS	
	Settling time	$t_s$	—	1.8	—	$\mu\text{s}$	All bits on $\rightarrow$ off $\pm 1/2\text{LSB}$
	Output voltage range	$I_{OR}$	0	—	2.1	mA	DAC, $I_{REF} = 2\text{ mA}$
	Input current 1	$I_{ODAC1}$	1.42	1.49	1.57	mA	$I_{REF} = 1.5\text{ mA}$ , All bits high
	Input current 2	$I_{ODAC2}$	—	0	3.0	$\mu\text{A}$	$I_{REF} = 1.5\text{ mA}$ , All bits low
	Reference voltage	$I_{DREF}$	1.0	—	2.0	mA	
Op amp block	Input bias current	$I_B$	—	300	700	nA	4
	Input offset voltage	$V_{IO}$	—	(3.0)	7.7	mV	
	Output offset voltage	$V_{OS}$	—	(3.0)	9.0	mV	
	Maximum output voltage	$V_{OCM1}$	9.8	—	—	V	
	Minimum output voltage		—	—	1.82	V	
	Slew rate	SR	1.0	2.4	—	V/ $\mu\text{s}$	
Analog switch	On resistance	$R_{ON}$	300	500	750	$\Omega$	
	Turn on time	$t_{ON}$	—	0.4	1.0	$\mu\text{s}$	
	Turn off time	$t_{OFF}$	—	0.4	1.0	$\mu\text{s}$	

## Notes:

1. Common to HA16671MP and HA16672MP.
2. Applies to HA16671MP.
3. Applies to HA16672MP.
4. Characteristic values of the op amp and analog switch included in the HA16671MP and HA16672MP.
5. Values in parentheses are preliminary.



Example

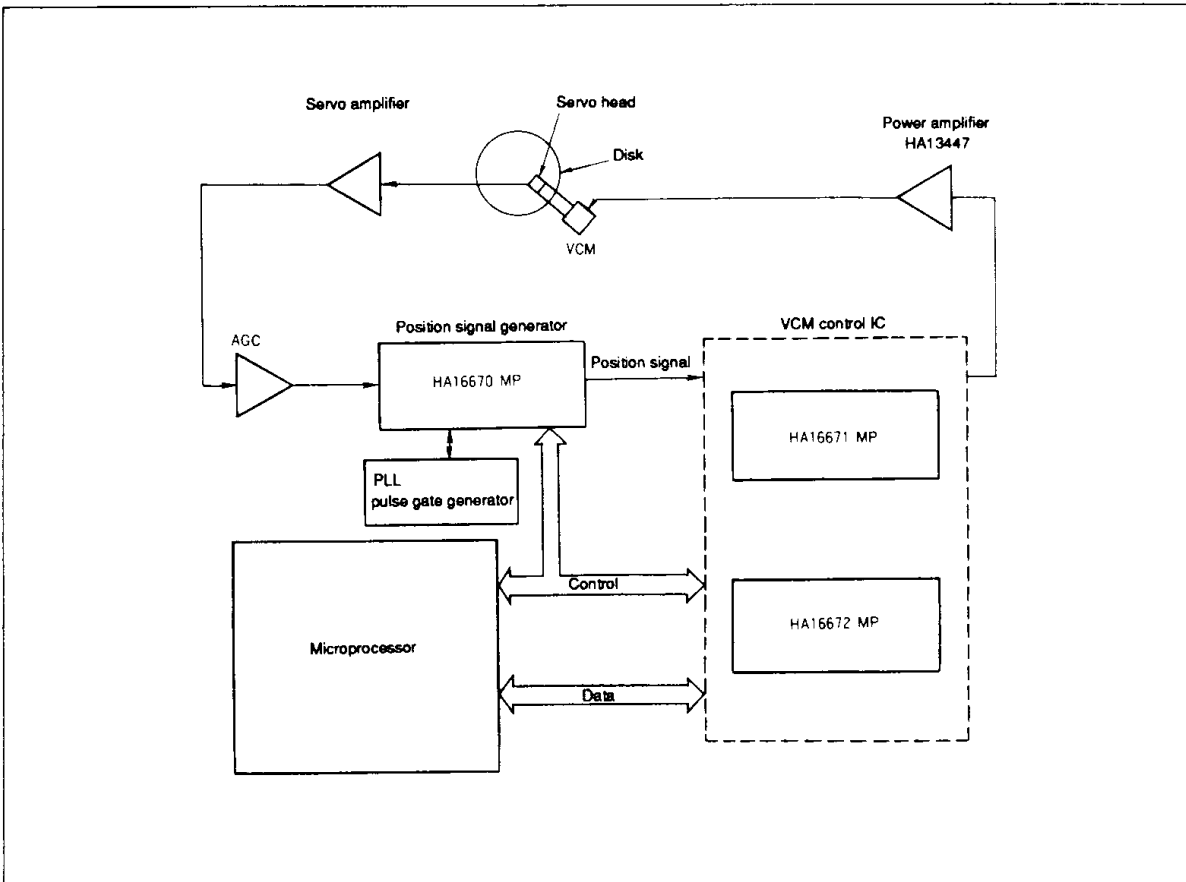

# HA16671MP, HA16672MP

## Phase Servo Mode Circuit Example

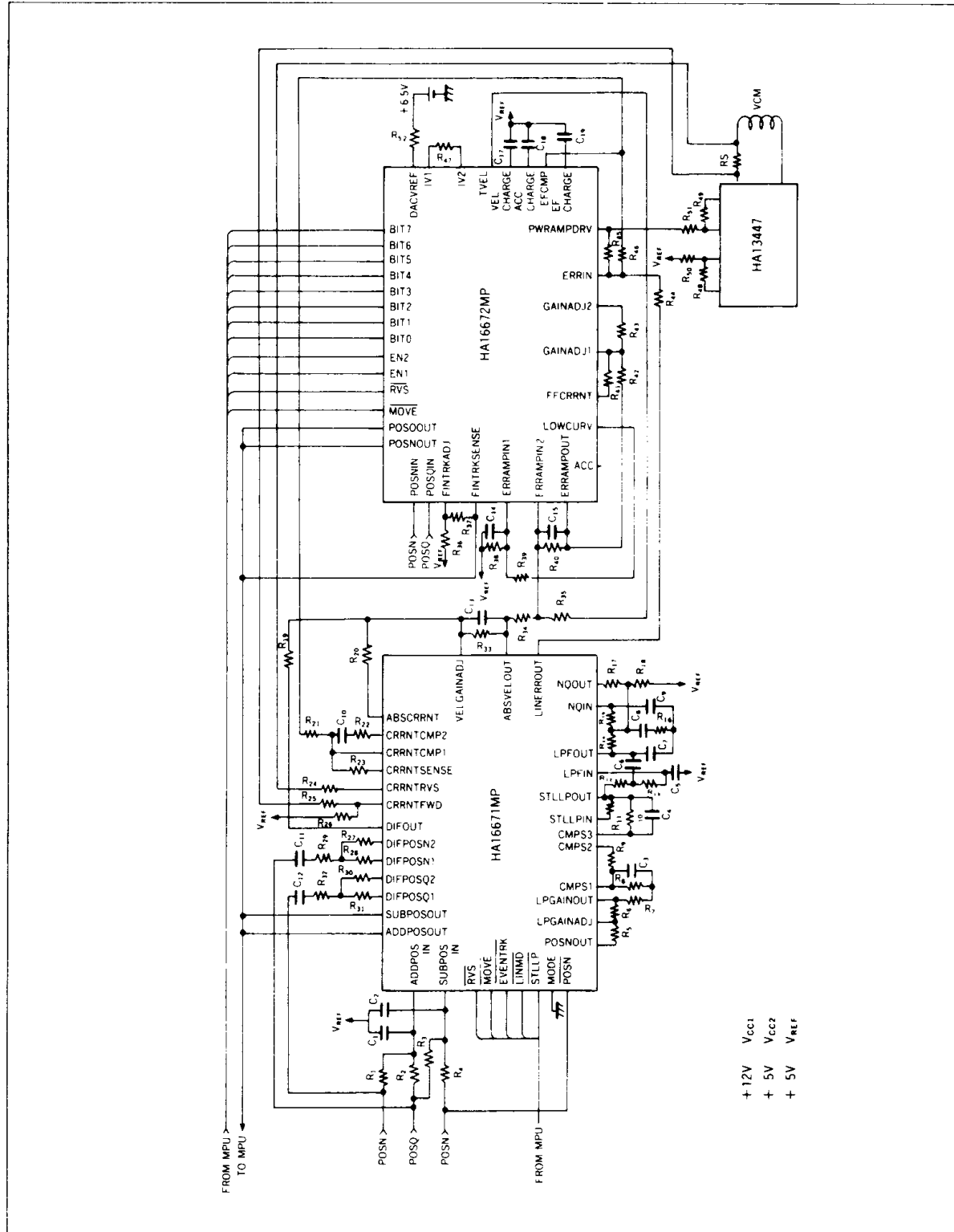

# HA16671MP, HA16672MP

## HA16671MP Internal Circuit

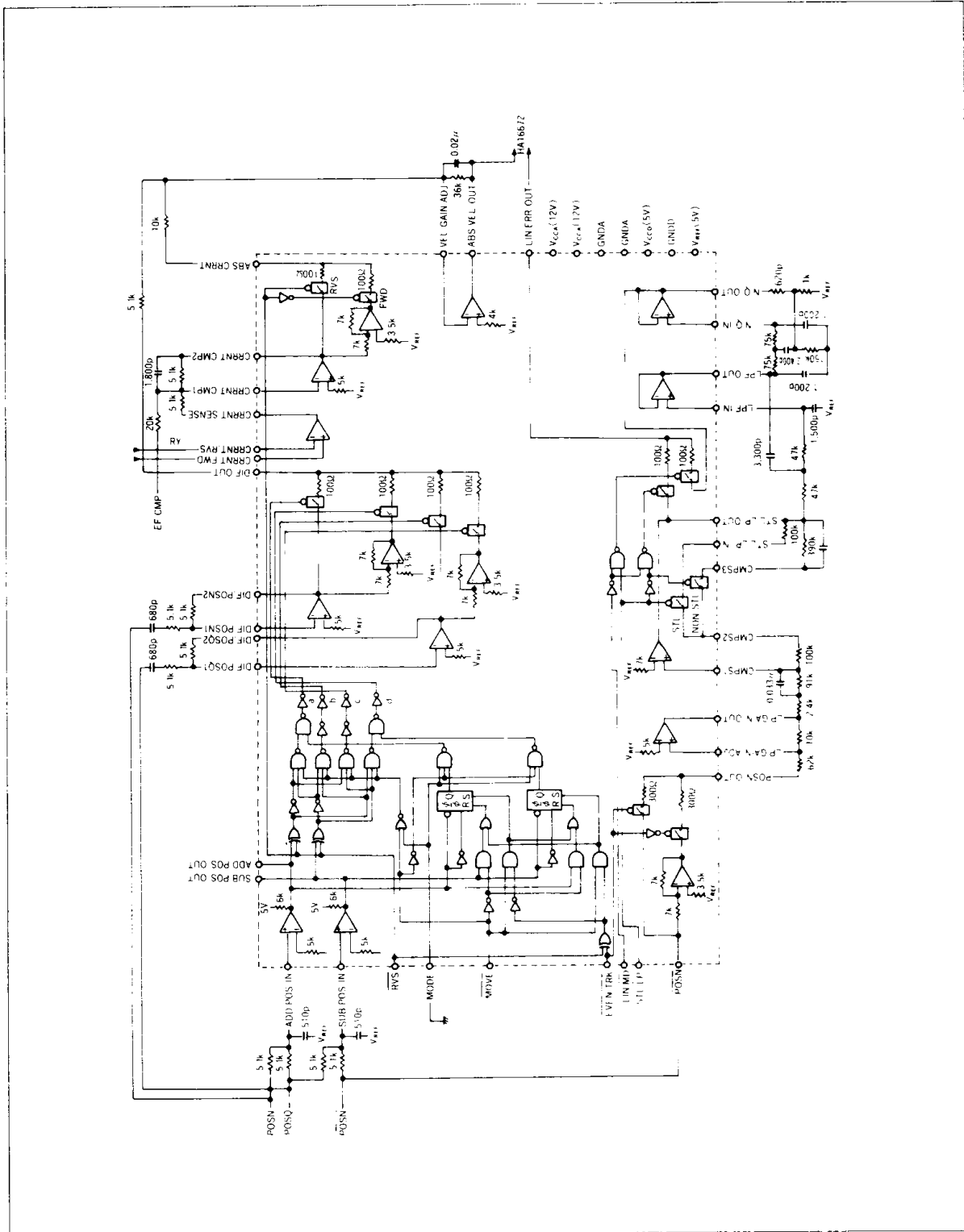

# HA16671MP, HA16672MP

## HA16672MP Internal Circuit

