

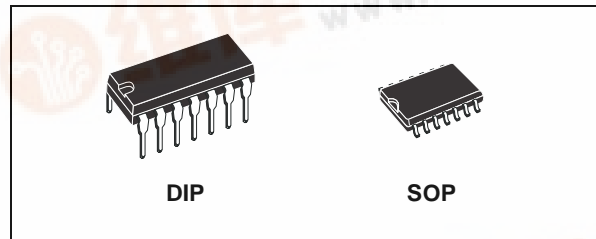

# HCF4016B

## QUAD BILATERAL SWITCH

- 20V DIGITAL OR  $\pm 10V$  PEAK TO PEAK SWITCHING
- 280 $\Omega$  TYPICAL ON RESISTANCE FOR 15V OPERATION
- SWITCH ON RESISTANCE MATCHED TO WITHIN 10 $\Omega$  TYP. OVER 15V SIGNAL INPUT RANGE
- HIGH ON/OFF OUTPUT VOLTAGE RATIO : 65dB TYP. at  $f_{IS} = 10KHz$ ,  $R_L = 10K\Omega$
- HIGH DEGREE OF LINEARITY : < 0.5% DISTORTION TYP. at  $f_{IS} = 1KHz$ ,  $V_{IS} = 5 V_{pp}$ ,  $V_{DD} - V_{SS} \geq 10V$ ,  $R_L = 10K\Omega$
- EXTREMELY LOW OFF SWITCH LEAKAGE RESULTING IN VERY LOW OFFSET CURRENT AND HIGH EFFECTIVE OFF RESISTANCE : 100pA TYP. at  $V_{DD} - V_{SS} = 18V$ ,  $T_{amb} = 25^\circ C$
- EXTREMELY HIGH CONTROL INPUT IMPEDANCE (control circuit isolated from signal circuit 10<sup>12</sup> $\Omega$  typ.)
- LOW CROSSTALK BETWEEN SWITCHES : 50dB Typ. at  $f_{IS} = 0.9MHz$ ,  $R_L = 1K\Omega$
- MATCHED CONTROL - INPUT TO SIGNAL OUTPUT CAPACITANCE : REDUCES OUTPUT SIGNAL TRANSIENTS
- FREQUENCY RESPONSE SWITCH ON : 40MHz (Typ.)
- QUIESCENT CURRENT SPECIF. UP TO 20V
- 5V, 10V AND 15V PARAMETRIC RATINGS
- INPUT LEAKAGE CURRENT  $I_l = 100nA$  (MAX) AT  $V_{DD} = 18V$   $T_A = 25^\circ C$



### ORDER CODES

PACKAGE	TUBE	T & R
DIP	HCF4016BEY	
SOP	HCF4016BM1	HCF4016M013TR

- 100% TESTED FOR QUIESCENT CURRENT
- MEETS ALL REQUIREMENTS OF JEDEC JESD13B " STANDARD SPECIFICATIONS FOR DESCRIPTION OF B SERIES CMOS DEVICES"

### DESCRIPTION

The HCF4016B is a monolithic integrated circuit fabricated in Metal Oxide Semiconductor technology available in DIP and SOP packages. The HCF4016B is a QUAD BILATERAL SWITCH intended for the transmission or multiplexing of analog or digital signals. Each of the four independent bilateral switches has a single control signal input which simultaneously biases both the p and n device in a given switch ON or OFF.

### PIN CONNECTION

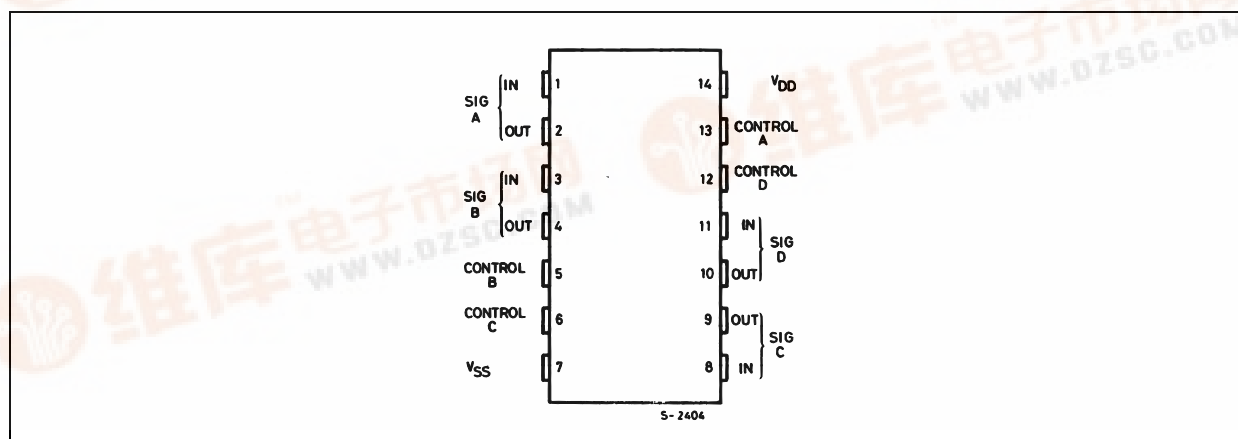

# HCF4016B

## INPUT EQUIVALENT CIRCUIT

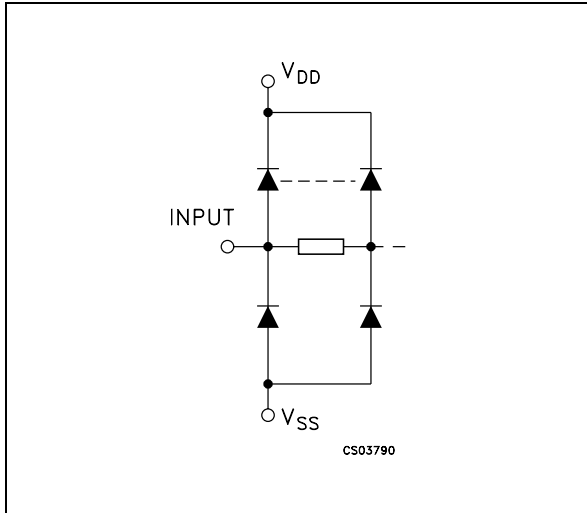

## PIN DESCRIPTION

PIN No	SYMBOL	NAME AND FUNCTION
1, 4, 8, 11	A to D I/O	Independent Inputs/Outputs
2, 3, 9, 10	A to D O/I	Independent Outputs/Inputs
13, 5, 6, 12	CONTROL A to D	Enable Inputs
7	V <sub>SS</sub>	Negative Supply Voltage
14	V <sub>DD</sub>	Positive Supply Voltage

## TRUTH TABLE

CONTROL	SWITCH FUNCTION
H	ON
L	OFF

## FUNCTIONAL DIAGRAM

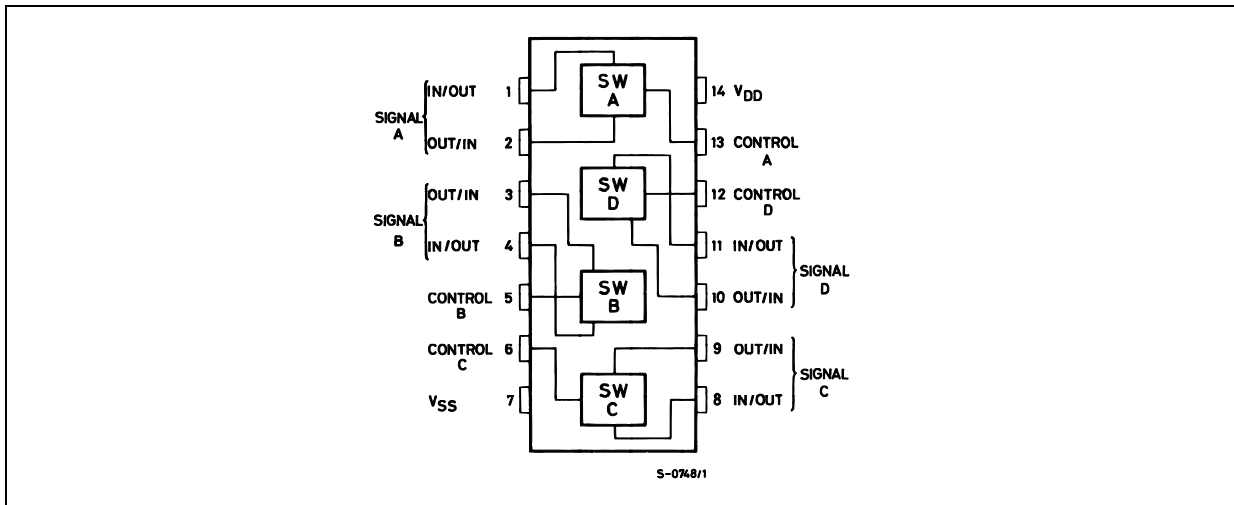

## ABSOLUTE MAXIMUM RATINGS

Symbol	Parameter	Value	Unit
V <sub>DD</sub>	Supply Voltage	-0.5 to +22	V
V <sub>I</sub>	DC Input Voltage	-0.5 to V <sub>DD</sub> + 0.5	V
I <sub>I</sub>	DC Input Current	± 10	mA
P <sub>D</sub>	Power Dissipation per Package	200	mW
	Power Dissipation per Output Transistor	100	mW
T <sub>op</sub>	Operating Temperature	-55 to +125	°C
T <sub>stg</sub>	Storage Temperature	-65 to +150	°C

Absolute Maximum Ratings are those values beyond which damage to the device may occur. Functional operation under these conditions is not implied. All voltage values are referred to V<sub>SS</sub> pin voltage.

## RECOMMENDED OPERATING CONDITIONS

Symbol	Parameter	Value	Unit
$V_{DD}$	Supply Voltage	3 to 20	V
$V_I$	Input Voltage	0 to $V_{DD}$	V
$T_{op}$	Operating Temperature	-55 to 125	°C

## DC SPECIFICATIONS

Symbol	Parameter	Test Condition			Value						Unit		
		$V_C = V_{DD}$	$V_{SS} (V)$	$V_{DD} (V)$	$T_A = 25^\circ C$			$-40 \text{ to } 85^\circ C$		$-55 \text{ to } 125^\circ C$			
					Min.	Typ.	Max.	Min.	Max.	Min.		Max.	
$I_L$	Quiescent Device Current (all switches ON or all switches OFF)			5		0.01	0.25		7.5		7.5	$\mu A$	
				10		0.01	0.5		15		15		
				15		0.01	1		30		30		
				20		0.02	5		150		150		
<b>SWITCH</b>													
$R_{ON}$	Resistance	$R_L = 10K\Omega$	+7.5	-7.5	+7.5		200	400		600		600	$\Omega$
					-7.5		200	400		600		600	
					$\pm 0.25$		280	850		1230		1230	
			+5	-5	+5		250	660		840		840	
					-5		250	660		840		840	
					$\pm 0.25$		580	2000		2380		2380	
			+15	0	+15		200	400		520		520	
					+0.25		200	400		520		520	
					+9.3		300	800		1080		1080	
					+10		250	660		840		840	
+10	0	+0.25		250	660		840		840				
		+5.6		560	2000		2380		2380				
$\Delta_{ON}$	Resistance $\Delta_{RON}$ (between any 2 of 4 switches)	$R_L = 10K\Omega$	+7.5	-7.5	$\pm 7.5$		10					$\Omega$	
			+5	-5	$\pm 5$		15						
Input or Output Leakage Current Switch OFF (effective off resistance)			$V_{DD} +15$	$V_C = V_{SS} 0$			$10^{-5}$	$\pm 0.3$		$\pm 1$		$\mu A$	
$C_I$	Input Capacitance	$V_{CC} = V_{SS} = -5$			+5		4					pF	
$C_O$	Output Capacitance	$V_{CC} = V_{SS} = -5$			+5		4						
$C_{IO}$	Feedthrough	$V_{CC} = V_{SS} = -5$			+5		0.2						
<b>CONTROL (<math>V_C</math>)</b>													
$V_{TH}$	Switch Threshold Voltage	$I_{IS} = 10 \mu A$			5		2.25		1		1		V
					10		4.5		2		2		
					15		6.75		2		2		
$I_I$	Input Current	$V_{IS} \leq V_{DD}$			18		$\pm 10^{-5}$	$\pm 0.1$		$\pm 1$		$\mu A$	
$C_I$	Input Capacitance						5	7.5				pF	

## HCF4016B

**DYNAMIC ELECTRICAL CHARACTERISTICS** ( $T_{amb} = 25^{\circ}\text{C}$ ,  $C_L = 50\text{pF}$ , all input square wave rise and fall time = 20 ns )

Parameter	Test Condition						Value			Unit	
	$V_C$ (V)	$R_L$ (K $\Omega$ )	$f_I$ (KHz)	$V_I$ (V)	$V_{SS}$ (V)	$V_{DD}$ (V)	Min.	Typ.	Max.		
Propagation Delay Time (signal input to output)	$= V_{DD}$	10		10sq. Wave	GND	5		40	100	ns	
						10		20	50		
						15		15	40		
Crosstalk Between any 2 of 4 Switches (f at -50dB) 20 log 10 $V_{O(B)}/V_{I(A)}$ = -50dB	$V_{C(A)} = V_{DD} = +5$ $V_{C(B)} = V_{SS} = -5$	1		$V_{I(A)} \Delta = 5\text{p-p}$				0.9		MHz	
Feedthrough(switch OFF) at 20 log 10 $V_O/V_I = -50\text{dB}$	$= V_{DD} = +5$	1		5p-p		5		1.25		MHz	
Frequency Response Switch"ON" (sine wave input) at 20 log 10 $V_O/V_I = -3\text{dB}$	$= V_{SS} = -5$	1		-5p-p	-5			40		MHz	
Sine Wave Distortion	$= V_{DD} = 5$	10	1	5p-p	-5			0.4		%	
<b>CONTROL (<math>V_C</math>)</b>											
Propagation Delay Time (turn on control to output)	$V_{DD} - V_{SS}$ (sq. wave)	1		$V_{DD}$ or $V_{SS}$		5	$V_{DD} - V_{SS} = 10\text{V}$		35	70	ns
						10			20	40	
						15			15	30	
Max. Allowable Control Input Repetition Rate	10 (sq. wave)	1		$V_{DD}$	GND	10		10		MHz	
Crosstalk (control Input to signal output)	10 (sq. wave)	10			GND	10		50		mV	

( $\Delta$ ) Symmetrical about OV

TYPICAL "ON" RESISTANCE CHARACTERISTICS,  $T_{amb} = 25^{\circ}\text{C}$

Characteristics*	Supply Conditions		Load Conditions					
			RL = 1KΩ		RL = 10KΩ		RL = 100KΩ	
	V <sub>DD</sub> (V)	V <sub>SS</sub> (V)	Value (Ω)	V <sub>is</sub> (V)	Value (Ω)	V <sub>is</sub> (V)	Value (Ω)	V <sub>is</sub> (V)
R <sub>ON</sub>	+ 15	0	200	+ 15	200	+ 15	180	+ 15
			200	0	200	0	200	0
R <sub>ON</sub> (max.)	+ 15	0	300	+ 11	300	+ 9.3	300	+ 9.2
R <sub>ON</sub>	+ 10	0	290	+ 10	250	+ 10	240	+ 10
			290	0	250	0	300	0
R <sub>ON</sub> (max.)	+ 10	0	500	+ 7.4	560	+ 5.6	610	+ 5.5
R <sub>ON</sub>	+ 5	0	860	+ 5	470	+ 5	450	+ 5
			600	0	580	0	800	0
R <sub>ON</sub> (max.)	+ 5	0	1.7K	+ 4.2	7K	+ 2.9	33K	+ 2.7
R <sub>ON</sub>	+ 2.5	- 2.5	590	+ 2.5	450	+ 2.5	490	+ 2.5
			720	- 2.5	520	- 2.5	520	- 2.5
R <sub>ON</sub> (max.)	+ 2.5	- 2.5	232K	± 0.25	300K	± 0.25	870K	± 0.25

\* Variation from a perfect switch, R<sub>ON</sub> = 0Ω

TEST CIRCUIT

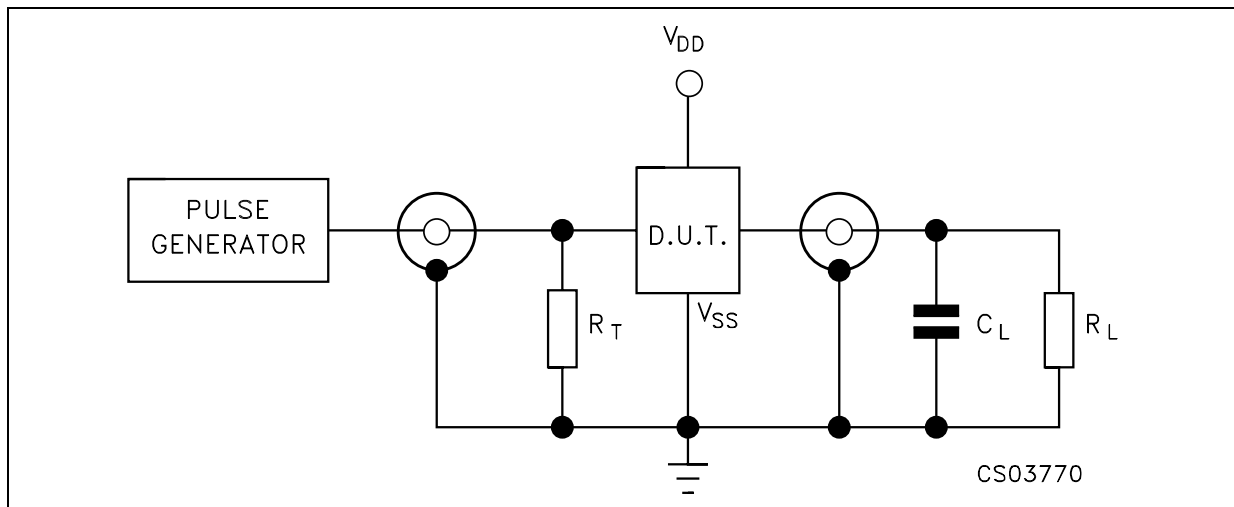

C<sub>L</sub> = 50pF or equivalent (includes jig and probe capacitance)  
 R<sub>L</sub> = 200KΩ  
 R<sub>T</sub> = Z<sub>OUT</sub> of pulse generator (typically 50Ω)

# HCF4016B

## SWITCHING CHARACTERISTICS TEST CIRCUIT

### SQUARE-WAVE RESPONSE

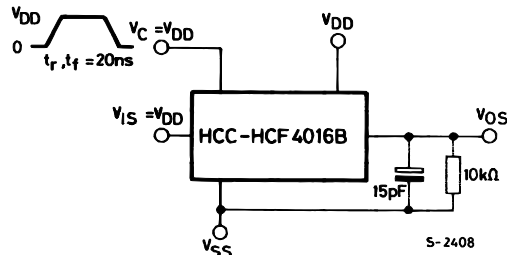

ALL UNUSED TERMINALS ARE CONNECTED TO VSS

### PROPAGATION DELAY TIME SIGNAL INPUT (V<sub>IS</sub>) TO SIGNAL OUTPUT (V<sub>OS</sub>)

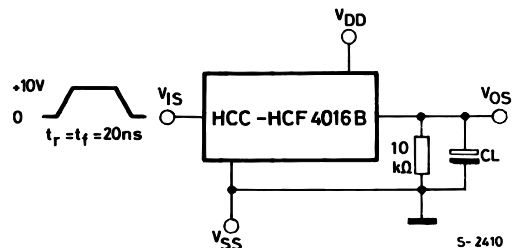

ALL UNUSED TERMINALS ARE CONNECTED TO VSS

### MAX ALLOWABLE CONTROL-INPUT REPETITION RATE

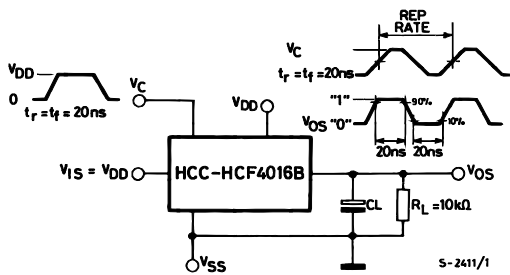

ALL UNUSED TERMINALS ARE CONNECTED TO VSS

### SWITCH TRESHOLD VOLTAGE

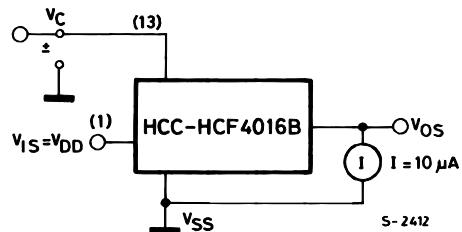

SWITCH THRESHOLD VOLTAGE IS DEFINED AS THE VOLTAGE APPLIED TO A TRANSMISSION GATE CONTROL WHICH CAUSES 10µA OF TRANSMISSION GATE CURRENT.

### CAPACITANCE C<sub>IOS</sub> AND C<sub>OIS</sub>

MEASURED ON BOONTON CAPACITANCE BRIDGE MODEL 75A (1MHz)

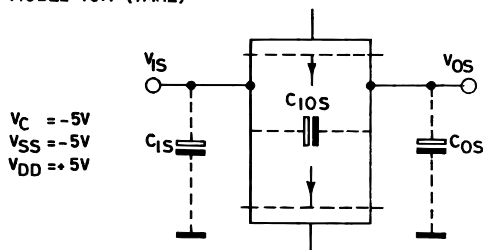

ALL UNUSED TERMINALS ARE CONNECTED TO VSS

S-2413

### CROSSTALK CONTROL INPUT TO SIGNAL OUTPUT

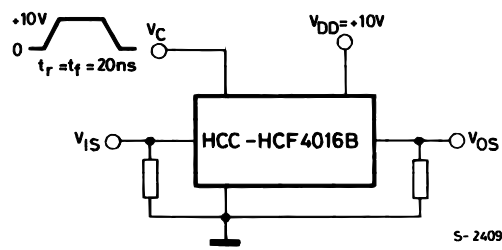

ALL UNUSED TERMINALS ARE CONNECTED TO VSS

S-2409

### TURN-ON PROPAGATION DELAY-CONTROL INPUT TO OUTPUT

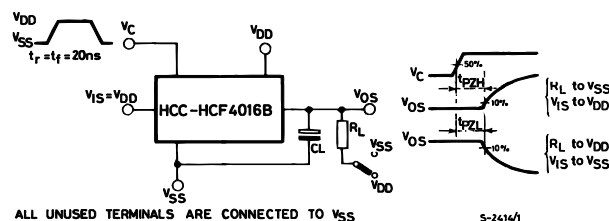

ALL UNUSED TERMINALS ARE CONNECTED TO VSS

S-2414/1

**Plastic DIP-14 MECHANICAL DATA**

DIM.	mm.			inch		
	MIN.	TYP.	MAX.	MIN.	TYP.	MAX.
a1	0.51			0.020		
B	1.39		1.65	0.055		0.065
b		0.5			0.020	
b1		0.25			0.010	
D			20			0.787
E		8.5			0.335	
e		2.54			0.100	
e3		15.24			0.600	
F			7.1			0.280
l			5.1			0.201
L		3.3			0.130	
Z	1.27		2.54	0.050		0.100

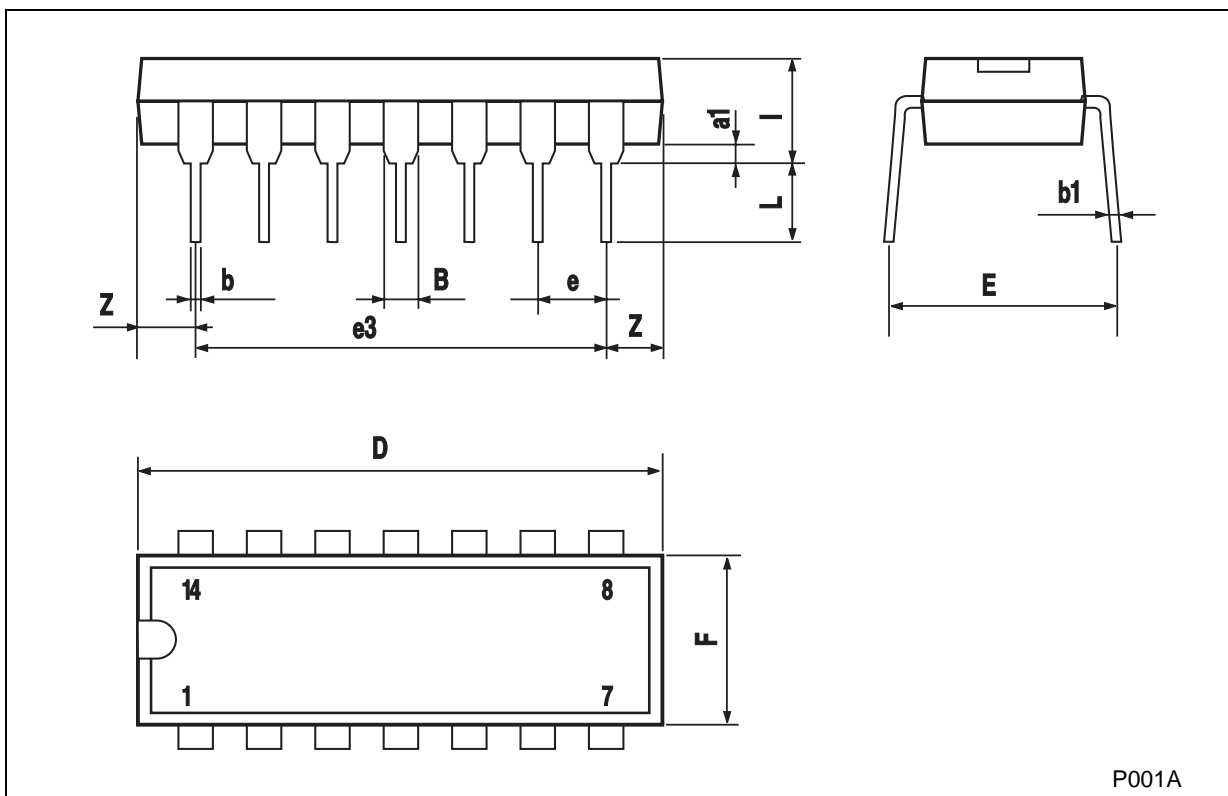

P001A

**SO-14 MECHANICAL DATA**

DIM.	mm.			inch		
	MIN.	TYP	MAX.	MIN.	TYP.	MAX.
A			1.75			0.068
a1	0.1		0.2	0.003		0.007
a2			1.65			0.064
b	0.35		0.46	0.013		0.018
b1	0.19		0.25	0.007		0.010
C		0.5			0.019	
c1	45° (typ.)					
D	8.55		8.75	0.336		0.344
E	5.8		6.2	0.228		0.244
e		1.27			0.050	
e3		7.62			0.300	
F	3.8		4.0	0.149		0.157
G	4.6		5.3	0.181		0.208
L	0.5		1.27	0.019		0.050
M			0.68			0.026
S	8° (max.)					

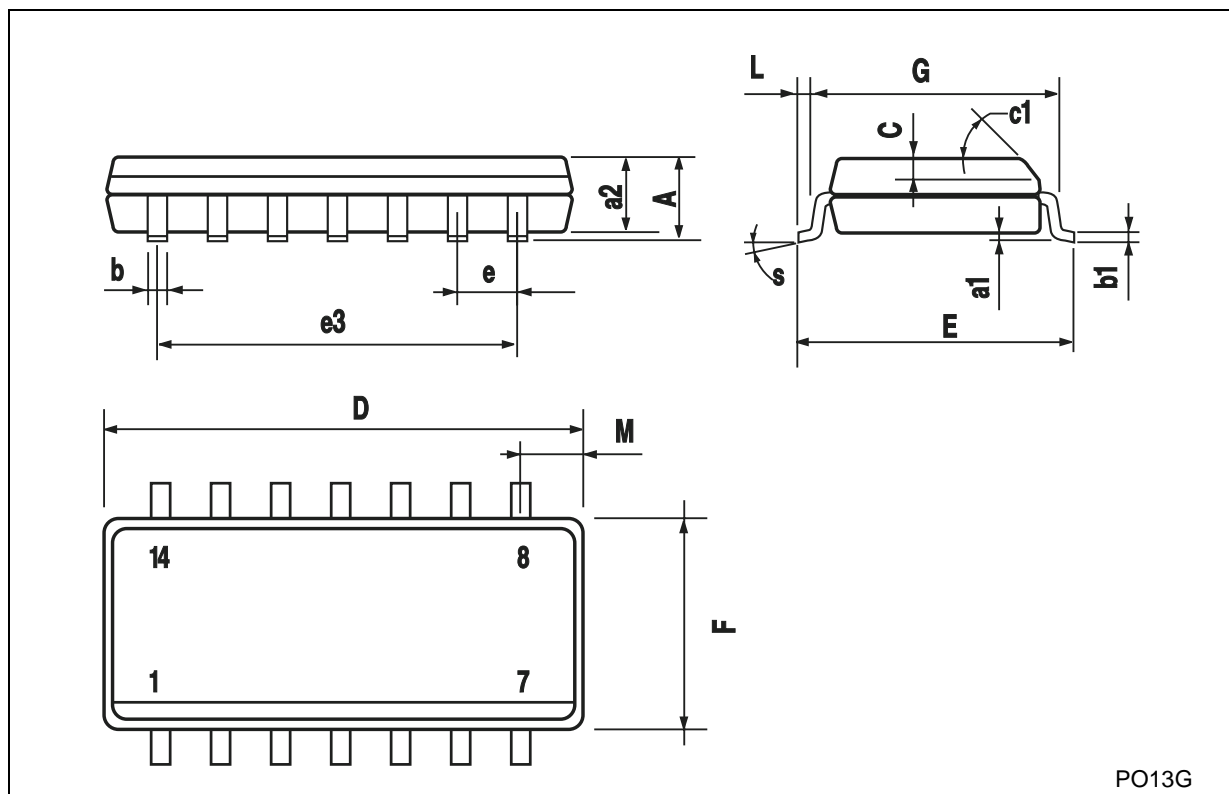

PO13G



Information furnished is believed to be accurate and reliable. However, STMicroelectronics assumes no responsibility for the consequences of use of such information nor for any infringement of patents or other rights of third parties which may result from its use. No license is granted by implication or otherwise under any patent or patent rights of STMicroelectronics. Specifications mentioned in this publication are subject to change without notice. This publication supersedes and replaces all information previously supplied. STMicroelectronics products are not authorized for use as critical components in life support devices or systems without express written approval of STMicroelectronics.

© The ST logo is a registered trademark of STMicroelectronics

© 2001 STMicroelectronics - Printed in Italy - All Rights Reserved  
STMicroelectronics GROUP OF COMPANIES

Australia - Brazil - China - Finland - France - Germany - Hong Kong - India - Italy - Japan - Malaysia - Malta - Morocco  
Singapore - Spain - Sweden - Switzerland - United Kingdom

© <http://www.st.com>

