



HD29468

Triple Line Drivers/Receivers

REJ03D0307-0200Z
 (Previous ADE-205-583 (Z))
 Rev.2.00
 Jul.16.2004

Description

The HD29468 features line drivers and receivers for unbalanced transmissions, which meet the specs of IBM 360 and 370. This device has three drivers and receivers in one package. Input of driver and output of receiver are compatible with low power schottky TTL circuit and operates from a single 5 V power supply. The driver has two types of enable inputs. Spurious noise can be prevented by grounding either input when power supply is throw or cut off. The outputs are protected from short circuit and the wired logic is available due to emitter follower from for party line data bus applications. The device operates at high speed. Low to high level and high to low level propagation delay times defference are 10 ns max.

Features

- Ordering Information

Part Name	Package Type	Package Code	Package Abbreviation	Taping Abbreviation (Quantity)
HD29468P	DILP-16 pin	DP-16E, -16FV	P	—

Pin Arrangement

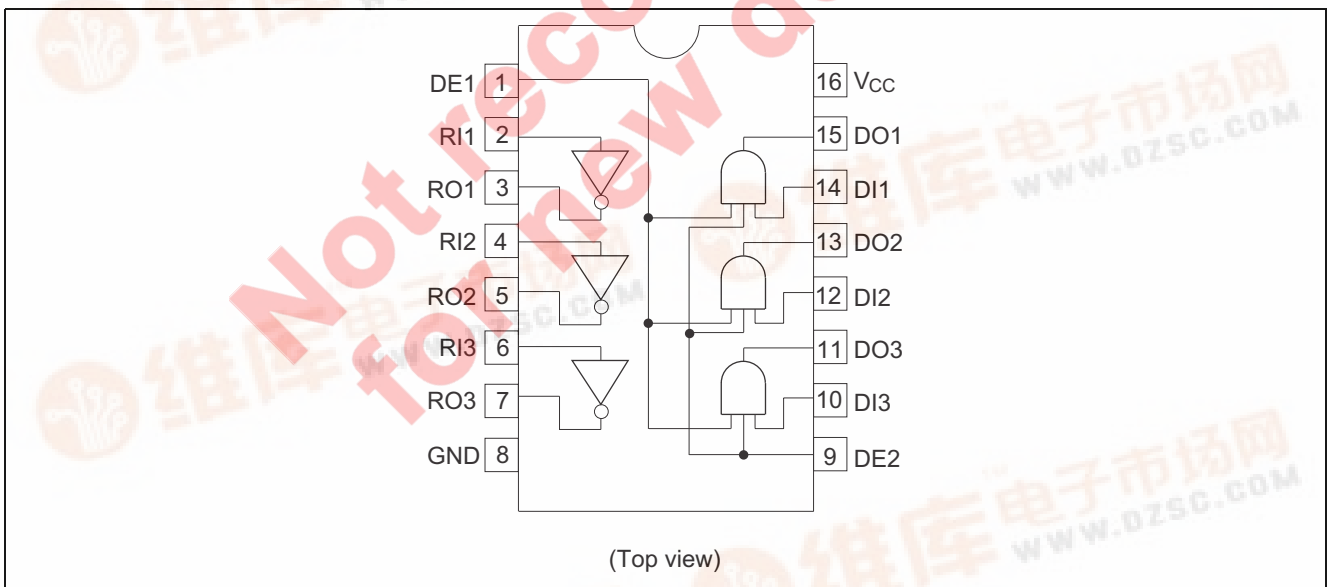

Function Table

Driver			Receiver		
Input			Output DO	Input	Output
DI	DE1	DE2		RI	RO
L	X	X	L	L	H
X	L	X	L	H	L
X	X	L	L		
H	H	H	H		

H : High level
 L : Low level
 X : Immaterial

Absolute Maximum Ratings

Item	Symbol	Ratings	Unit
Supply Voltage	V_{CC}	+7	V
Driver Input Voltage	V_{ID}	-0.5 to +7	V
Driver Output Voltage	V_{OD}	-0.5 to +7	V
Receiver Input Voltage	V_{IR}	-0.5 to +7	V
Power Dissipation ($T_a = 25^\circ\text{C}$)* ¹	DP	1000	mW
	FP	785	
Operating Temperature	T_a	0 to +75	°C
Storage Temperature	T_{stg}	-65 to +150	°C

Notes: 1. The above data were taken by the ΔV_{BE} method, mounting on a glass epoxy board (40 × 40 × 1.6 mm) of 10% wiring density.
 2. The absolute maximum ratings are values which must not individually be exceeded, and furthermore, no two of which may be realized at the same time.

Recommended Operating Conditions

Item	Symbol	Min	Typ	Max	Unit
Supply Voltage	V_{CC}	4.75	5.00	5.25	V
Operating Temperature	T_a	0	—	75	°C

Electrical Characteristics

Driver ($V_{CC} = 5.0 \text{ V} \pm 5\%$, $T_a = 0 \text{ to } +75^\circ\text{C}$)

Item	Symbol	Min	Max	Unit	Conditions	
High Level Input Voltage	V_{IH}	2.0	—	V		
Low Level Input Voltage	V_{IL}	—	0.8	V		
Input Clamp Voltage	V_{IK}	—	-1.5	V	$V_{CC} = 4.75 \text{ V}$, $I_{IN} = -18 \text{ mA}$	
High Level Output Voltage	V_{OH}	3.11	—	V	$V_{CC} = 4.75 \text{ V}$, $V_{IH} = 2.0 \text{ V}$ $I_{OH} = -59.3 \text{ mA}$ ($T_a = 25^\circ\text{C}$)	
		—	4.1		$V_{CC} = 5.25 \text{ V}$, $V_{IH} = 2.0 \text{ V}$ $I_{OH} = -78.1 \text{ mA}$	
Low Level Output Voltage	V_{OL}	—	0.15	V	$V_{CC} = 5.25 \text{ V}$, $V_{IL} = 0.8 \text{ V}$ $I_{OL} = -0.24 \text{ mA}$, $V_{IH} = 4.5 \text{ V}$	
High Level Input Current	DI	I_{IH}	—	20	μA	$V_{CC} = 5.25 \text{ V}$, $V_{IH} = 2.7 \text{ V}$
	DE		—	60		$V_{CC} = 5.25 \text{ V}$, $V_{IH} = 2.7 \text{ V}$
Low Level Input Current	DI	I_{IL}	—	-400	μA	$V_{CC} = 5.25 \text{ V}$, $V_{IL} = 0.4 \text{ V}$
	DE		—	-1200		$V_{CC} = 5.25 \text{ V}$, $V_{IL} = 0.4 \text{ V}$
High Level Output Current	I_{OH}	—	100	μA	$V_{CC} = 4.75 \text{ V}$, $V_{IL} = 0 \text{ V}$, $V_{OH} = 5.0 \text{ V}$	
		—	100		$V_{CC} = 4.75 \text{ V}$, $V_{IH} = 4.5 \text{ V}$, $V_{OH} = 5.0 \text{ V}$	
Short Circuit Output Current	I_{OS}	—	-30	mA	$V_{CC} = 5.25 \text{ V}$, $V_{IH} = 4.5 \text{ V}$	

Receiver ($T_a = 0 \text{ to } +75^\circ\text{C}$)

Item	Symbol	Min	Max	Unit	Conditions
High Level Output Threshold Voltage	V_{OTH}	2.7	—	V	$V_{CC} = 4.75 \text{ V}$, $V_{IL} = 1.15 \text{ V}$ $I_{OH} = -400 \mu\text{A}$
Low Level Output Threshold Voltage	V_{OTL}	—	0.5	V	$V_{CC} = 5.25 \text{ V}$, $V_{IH} = 1.55 \text{ V}$ $I_{OL} = 8 \text{ mA}$
High Level Output Voltage	V_{OH}	2.7	—	V	$V_{CC} = 4.75 \text{ V}$, V_{IN} : Open $I_{OH} = -400 \mu\text{A}$
Low Level Output Voltage	V_{OL}	—	0.5	V	$V_{CC} = 4.75 \text{ V}$
		—	0.4		$V_{IH} = 1.55 \text{ V}$
					$I_{OL} = 8 \text{ mA}$
					$I_{OL} = 4 \text{ mA}$
Input Resistance	R_{IN}	7.4	20	$\text{K}\Omega$	$V_{CC} = 0 \text{ V}$
High Level Input Current	I_{IH}	—	0.42	mA	$V_{CC} = 4.75 \text{ V}$, $V_{IH} = 3.11 \text{ V}$
Low Level Input Current	I_{IL}	0.04	-0.24	mA	$V_{CC} = 5.25 \text{ V}$, $V_{IL} = 0.15 \text{ V}$
Short Circuit Output Current	I_{OS}	-20	-100	mA	$V_{CC} = 5.25 \text{ V}$, $V_{IL} = 0 \text{ V}$

Driver/Receiver ($T_a = 0 \text{ to } +75^\circ\text{C}$)

Item	Symbol	Min	Max	Unit	Conditions
Supply Voltage	I_{CCH}	—	37	mA	$V_{CC} = 5.25 \text{ V}$, $V_{IH} = 4.5 \text{ V}$
	I_{CCL}	—	55		$V_{CC} = 5.25 \text{ V}$, $V_{IL} = 0 \text{ V}$

Switching Characteristics

Driver ($V_{CC} = 5.0 \text{ V}$, $T_a = 25^\circ\text{C}$)

Item	Symbol	Min	Max	Unit	Conditions
Rise Propagation Delay Time	t_{PLH}	6.5	18.5	ns	$R_L = 47.5 \Omega$
Fall Propagation Delay Time	t_{PHL}	6.5	18.5	ns	
Propagation Delay Time Difference*1	Δt_{PD}	—	10	ns	

Note: 1. $\Delta t_{PD} = |t_{PLH} - t_{PHL}|$

HD29468

Receiver ($V_{CC} = 5.0 \text{ V}$, $T_a = 25^\circ\text{C}$)

Item	Symbol	Min	Max	Unit	Conditions
Rise Propagation Delay Time	t_{PLH}	7.5	19.5	ns	$R_L = 2 \text{ K}\Omega$, $C_L = 15\text{pF}$
Fall Propagation Delay Time	t_{PHL}	7.5	19.5	ns	$R_L = 2 \text{ K}\Omega$, $C_L = 15\text{pF}$
Propagation Delay Time Difference*1	Δt_{PD}	—	10	ns	$R_L = 2 \text{ K}\Omega$, $C_L = 15\text{pF}$

Note: 1. $\Delta t_{PD} = |t_{PLH} - t_{PHL}|$

Driver

Test Circuit

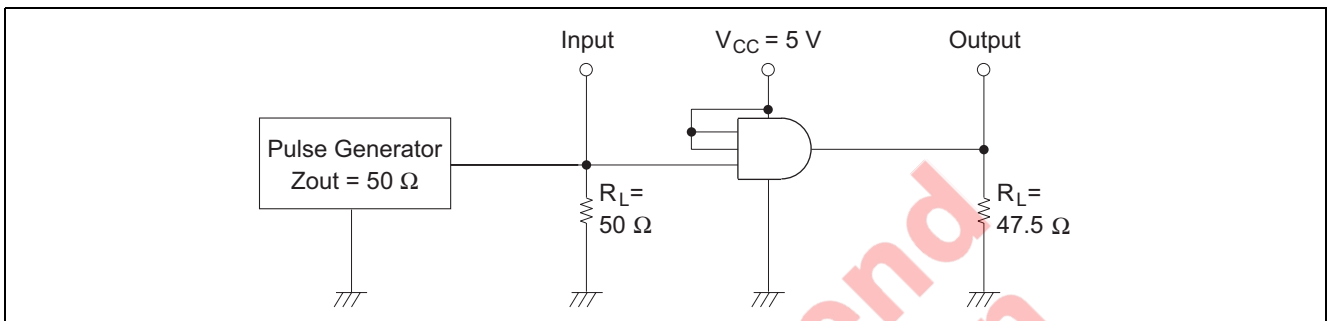

Waveforms

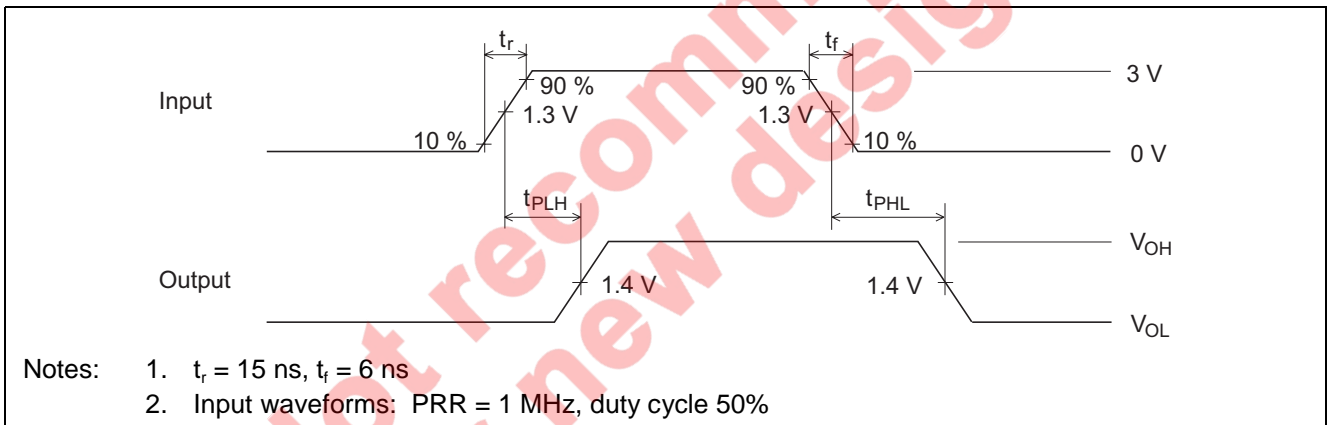

Receiver

Test Circuit

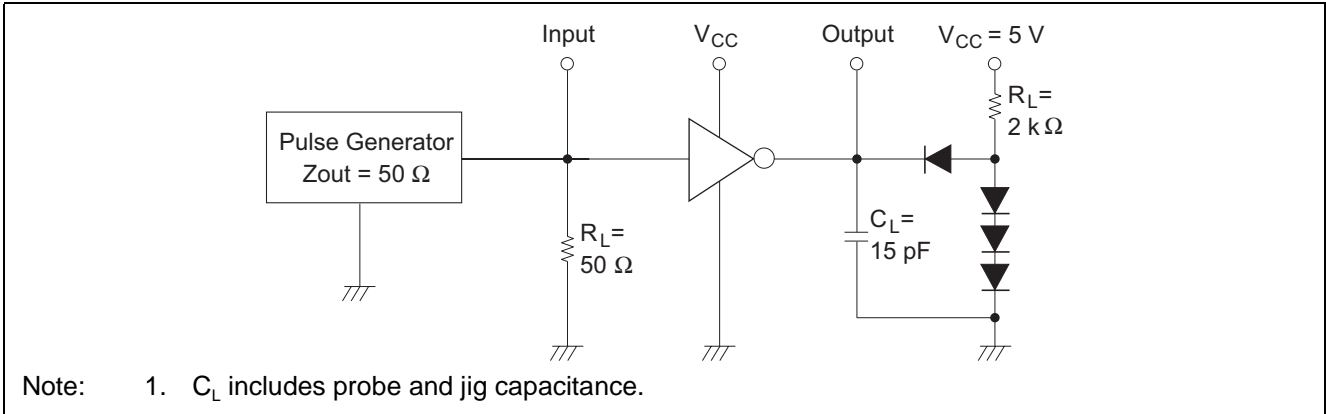

Waveforms

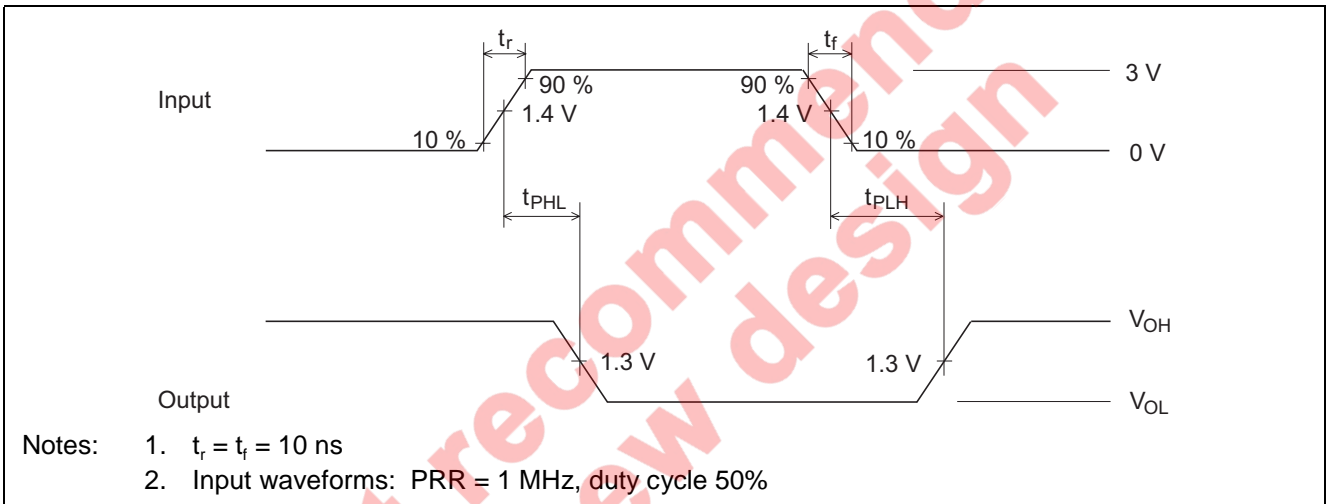

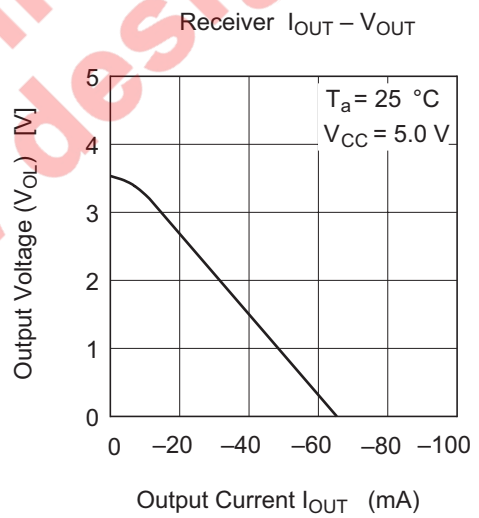
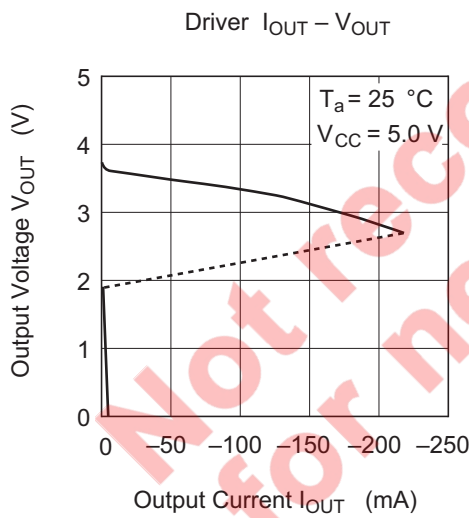
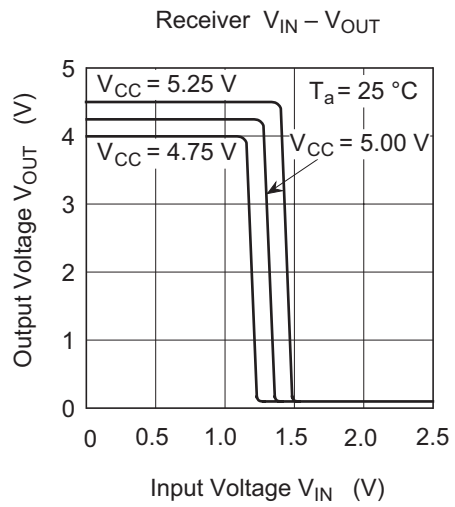
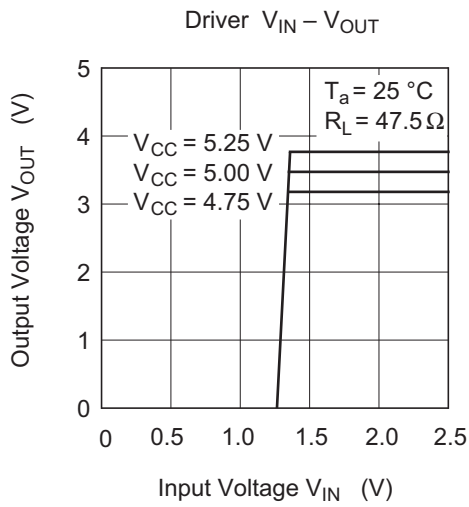

Package Dimensions

As of January, 2003
Unit: mm

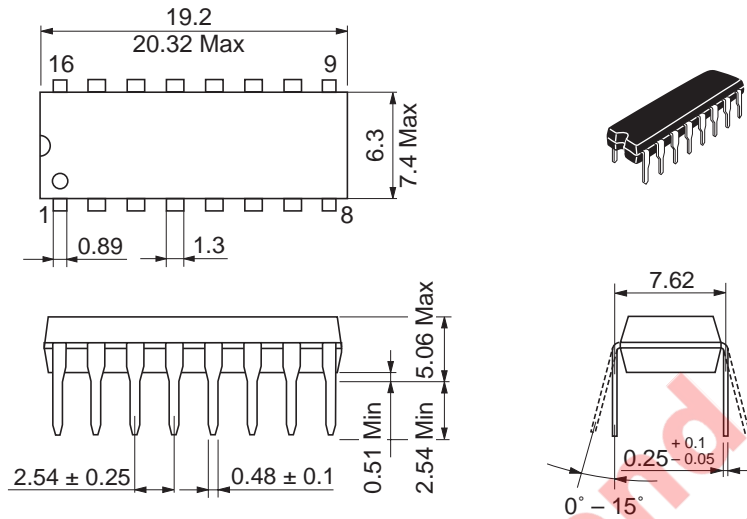

Package Code	DP-16E
JEDEC	Conforms
JEITA	Conforms
Mass (reference value)	1.05 g

Unit: mm

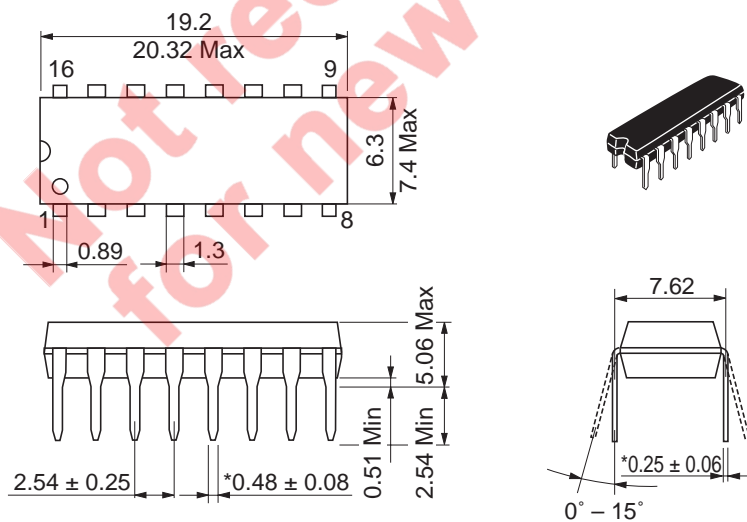

*Ni/Pd/AU Plating

Package Code	DP-16FV
JEDEC	Conforms
JEITA	Conforms
Mass (reference value)	1.05 g

Renesas Technology Corp. Sales Strategic Planning Div. Nippon Bldg., 2-6-2, Ohte-machi, Chiyoda-ku, Tokyo 100-0004, Japan

Keep safety first in your circuit designs!

1. Renesas Technology Corp. puts the maximum effort into making semiconductor products better and more reliable, but there is always the possibility that trouble may occur with them. Trouble with semiconductors may lead to personal injury, fire or property damage. Remember to give due consideration to safety when making your circuit designs, with appropriate measures such as (i) placement of substitutive, auxiliary circuits, (ii) use of nonflammable material or (iii) prevention against any malfunction or mishap.

Notes regarding these materials

1. These materials are intended as a reference to assist our customers in the selection of the Renesas Technology Corp. product best suited to the customer's application; they do not convey any license under any intellectual property rights, or any other rights, belonging to Renesas Technology Corp. or a third party.
2. Renesas Technology Corp. assumes no responsibility for any damage, or infringement of any third-party's rights, originating in the use of any product data, diagrams, charts, programs, algorithms, or circuit application examples contained in these materials.
3. All information contained in these materials, including product data, diagrams, charts, programs and algorithms represents information on products at the time of publication of these materials, and are subject to change by Renesas Technology Corp. without notice due to product improvements or other reasons. It is therefore recommended that customers contact Renesas Technology Corp. or an authorized Renesas Technology Corp. product distributor for the latest product information before purchasing a product listed herein.
The information described here may contain technical inaccuracies or typographical errors.
Renesas Technology Corp. assumes no responsibility for any damage, liability, or other loss rising from these inaccuracies or errors.
Please also pay attention to information published by Renesas Technology Corp. by various means, including the Renesas Technology Corp. Semiconductor home page (<http://www.renesas.com>).
4. When using any or all of the information contained in these materials, including product data, diagrams, charts, programs, and algorithms, please be sure to evaluate all information as a total system before making a final decision on the applicability of the information and products. Renesas Technology Corp. assumes no responsibility for any damage, liability or other loss resulting from the information contained herein.
5. Renesas Technology Corp. semiconductors are not designed or manufactured for use in a device or system that is used under circumstances in which human life is potentially at stake. Please contact Renesas Technology Corp. or an authorized Renesas Technology Corp. product distributor when considering the use of a product contained herein for any specific purposes, such as apparatus or systems for transportation, vehicular, medical, aerospace, nuclear, or undersea repeater use.
6. The prior written approval of Renesas Technology Corp. is necessary to reprint or reproduce in whole or in part these materials.
7. If these products or technologies are subject to the Japanese export control restrictions, they must be exported under a license from the Japanese government and cannot be imported into a country other than the approved destination.
Any diversion or reexport contrary to the export control laws and regulations of Japan and/or the country of destination is prohibited.
8. Please contact Renesas Technology Corp. for further details on these materials or the products contained therein.



RENESAS SALES OFFICES

<http://www.renesas.com>

Renesas Technology America, Inc.
450 Holger Way, San Jose, CA 95134-1368, U.S.A
Tel: <1> (408) 382-7500 Fax: <1> (408) 382-7501

Renesas Technology Europe Limited.
Dukes Meadow, Millboard Road, Bourne End, Buckinghamshire, SL8 5FH, United Kingdom
Tel: <44> (1628) 585 100, Fax: <44> (1628) 585 900

Renesas Technology Europe GmbH
Dornacher Str. 3, D-85622 Feldkirchen, Germany
Tel: <49> (89) 380 70 0, Fax: <49> (89) 929 30 11

Renesas Technology Hong Kong Ltd.
7/F., North Tower, World Finance Centre, Harbour City, Canton Road, Hong Kong
Tel: <852> 2265-6688, Fax: <852> 2375-6836

Renesas Technology Taiwan Co., Ltd.
FL 10, #99, Fu-Hsing N. Rd., Taipei, Taiwan
Tel: <886> (2) 2715-2888, Fax: <886> (2) 2713-2999

Renesas Technology (Shanghai) Co., Ltd.
26/F., Ruijin Building, No.205 Maoming Road (S), Shanghai 200020, China
Tel: <86> (21) 6472-1001, Fax: <86> (21) 6415-2952

Renesas Technology Singapore Pte. Ltd.
1, Harbour Front Avenue, #06-10, Keppel Bay Tower, Singapore 098632
Tel: <65> 6213-0200, Fax: <65> 6278-8001