



Preliminary

# HD66789

528-channel, One-chip Driver for Amorphous TFT Panels with 262,144-color display RAM, Power Supply Circuit, and Gate Circuit

REJxxxxxxx-xxxx  
Rev.0.12  
10 June, 2003

Description .....	5
Features .....	6
Block Diagram .....	7
Pin Functions .....	8
PAD arrangement.....	14
PAD Coordinate.....	15
BUMP Arrangements.....	17
Block Function.....	18
1. System Interface .....	18
2. External Display Interface .....	19
3. Bit Operations .....	19
4. Address Counter (AC) .....	19
5. Graphics RAM (GRAM) .....	19
7. Timing Generator.....	19
8. Oscillation Circuit (OSC) .....	20
9. LCD Driver Circuit.....	20
10.Liquid crystal drive power supply circuit .....	20
GRAM Address MAP .....	21
Instructions .....	28
Outline .....	28
Instructions .....	29
Index .....	29
Status Read .....	30
Start Oscillation (R00h) .....	30
Driver Output Control (R01h).....	30
LCD Driving Wave Form Control (R02h).....	32
Entry Mode (R03h) Compare Register 1 (R04h) Compare Register 2 (R05h) .....	33



Display Control 1 (R07h).....	36
Display Control 2 (R08h).....	38
Display control 3 (R09h) .....	40
Frame Cycle Control (R0Bh).....	41
External Display Interface Control (R0Ch) .....	44
Power Control 1 (R10h) Power Control 2 (R11h) .....	48
Power Control 3 (R12h) Power Control 4 (R13h) .....	51
RAM Address Set (R21h).....	53
Write Data to GRAM (R22h).....	54
RAM Access through RGB-I/F and System I/F.....	59
Read Data Read from GRAM (R22h).....	60
RAM Write Data Mask (R23h) RAM Write Data Mask (R24h) .....	63
$\gamma$ Control (R30h to R39h).....	64
Gate Scan Position (R40h).....	65
Vertical Scroll Control (R41h).....	66
1st-Screen Drive Position (R42h) 2nd-Screen Drive Position (R43h).....	66
Horizontal RAM Address Position (R44h) Vertical RAM Address Position (R45h) .....	67
Instruction List (T.B.D.) .....	68
Reset Function .....	69
Interface Specifications.....	71
System Interface.....	73
80-system 18-bit interface.....	74
80-system 16-bit interface.....	75
80-system 9-bit interface.....	76
Data transmission synchronizing in 9-bit bus interface mode.....	77
80-system 8-bit interface.....	78
Data transmission synchronizing in 8-bit bus interface mode.....	80
Serial Peripheral interface (SPI) .....	81
VSYNC Interface.....	84
Conditions on using VSYNC interface .....	86
External Display Interface .....	88
RGB interface .....	88
VLD and ENABLE signals.....	89
RGB interface timing .....	89
Moving picture display .....	91
RAM access through system interface in RGB-I/F mode.....	91
6-bit RGB interface.....	92
Data transmission synchronization in 6-bit RGB interface mode .....	92
16-bit RGB interface.....	93
18-bit RGB interface.....	94
Conditions on using external display interface .....	95

Timing Interfacing with Liquid Crystal Panel Signals .....	97
Scan Mode Setting .....	99
High-Speed Burst RAM Write Function .....	100
Conditions on using high-speed RAM write mode .....	101
High-Speed RAM Write with Window Address.....	103
Window Address Function .....	105
Graphics Operation Function .....	106
Graphics Operation .....	106
Write-data Mask Function .....	107
Graphics Operation Processing.....	107
$\gamma$ -Correction Function .....	111
Configuration of Grayscale Amplifier .....	112
$\gamma$ -Correction Register .....	114
Ladder resistors and 8-to-1 selector .....	115
Variable resistor .....	115
Relationship between RAM data and output level.....	121
8-color Display Mode .....	122
System Configuration .....	124
Configuration of Power Generation Circuit.....	125
Specification of External Elements Connected to HD66789 Power Supply .....	126
Instruction Setting Flow.....	127
Power Supply Setting Flow .....	129
Pattern Diagram for Voltage Setting.....	130
Oscillation Circuit.....	131
n-raster-row Inversion AC Drive .....	132
Interlaced Drive .....	133
AC Timing .....	135
Frame-Frequency Adjustment Function .....	136
Relationship between Liquid Crystal Drive Duty and Frame Frequency .....	136
Screen -split Drive Function .....	137

---

Conditions on Setting the 1st/2nd Screen Drive Position Register .....	138
Absolute Maximum Values .....	140
Electric Characteristics (T.B.D.).....	141
DC Characteristics .....	141
AC Characteristics .....	142
80-system Bus Interface Timing Characteristics.....	142
Clock Synchronized Serial Interface Timing Characteristics .....	145
Reset Timing Characteristics ( $V_{CC} = 1.8$ to $3.7$ V) .....	146
RGB interface timing characteristics .....	147
Liquid crystal driver output characteristics.....	149
Electrical Characteristics Notes .....	149
Load circuits for measuring AC characteristics .....	152
80-system Bus Operation.....	152
Clock Synchronized Serial Interface Operation.....	153
RESET Operation .....	153
RGB I/F Operation.....	154
Liquid crystal Driver Output.....	154

**Description**

The HD66789 handles 262,144 TFT colors and can drive a TFT color liquid crystal display of 176 RGB x 240 dots with an incorporated RAM compliant to graphics display of 176 RGB x 240 dots at maximum, and a 528-channel source driver outputs. The HD66789 incorporates a gate driver and a power circuit for driving liquid crystal display to drive a TFT panel with a single chip.

The HD66789's bit-operation functions, 8/9/16/18-bit high-speed bus interface, and high-speed RAM-write functions enable efficient transfer of data and high-speed data update on a graphics RAM. The HD66789's 6/16/18-bit RGB interface (VSYNC, HSYNC, DOTCLK, ENABLE, and PD 17 to 0) and VSYNC interface (system interface + VSYNC) provide an interface for moving picture display. With a window address function that facilitates the moving picture display in an arbitrary area and enables simultaneous display of moving pictures and the contents of the internal RAM, the HD66789 enables moving picture display not constrained by the still picture area. Accordingly, the data transmission is reduced to minimum, thereby saving power consumed by a system as a whole when displaying moving pictures.

The HD66789 supports power-saving operation up to the power supply voltage of 2.4V with a voltage follower circuit that generate voltage to drive liquid crystal. The HD66789 also incorporates 8-color display and standby functions that allow precise power control by software. These features make this LSI the ideal solution for any medium or small-sized portable battery-driven products such as digital cellular phones supporting WWW browsers or small PDA, where long battery life and board size are major concern.

## Features

- Liquid crystal controller/driver for 262,144 TFT-color 176RGB x 240-dot graphics display
- Single chip solution for a TFT display panel
- System interface
  - 8-/9-/16-/18-bit high-speed bus interface
  - Serial Peripheral Interface (SPI)
  - 8-bit transmission x 3 times (262k/65k color modes)
- Interface for moving picture display
  - 6-/16-/18-bit RGB interface (VSYNC, HSYNC, DOTCLK, ENABLE, PD17-0)
  - VSYNC interface (System interface + VSYNC)
- High-speed burst RAM write function
- Window address function to write data to the rectangular area of RAM specified by the window address
  - Interface to facilitate moving picture display in an arbitrary area
  - Reduce data transmission by transmitting only the data for the moving picture display area
  - Simultaneous display of moving pictures and the contents of the internal RAM
- Bit unit operations for processing graphics
  - Write data mask function by bit
- Functions for controlling abundant color displays
  - Simultaneous availability of 262,144 colors with  $\gamma$ -correction function
  - Line-unit vertical scrolling
- Low-power architecture: features for low-power operation
  - $V_{cc} = 2.4 \sim 3.3$  V (internal logic power supply)
  - $IOV_{cc} = 1.8 \sim 3.3$  V (interface I/O power supply)
  - $V_{ci} = 2.5 \sim 3.3$  V (analogue power supply)
  - $DDVDH = 4.5 \sim 5.5$  V (liquid-crystal drive voltage)
  - Power saving function (standby mode etc.)
  - Partial liquid crystal drive to display two screens at arbitrary positions
  - Voltage followers for liquid crystal drive power circuit to fend off the direct current from bleeder-resistors
- Step-up circuit generating liquid crystal drive voltage up to 6-time scale
- 95,040-byte internal RAM
- Incorporated liquid crystal display driver with 582 source outputs and 240 gate outputs
- n-raster-row liquid crystal AC drive, enabling polarity inversion by every arbitrary number of raster-rows
- Internal oscillation and hardware reset
- Reversible direction of signals between RAM and source driver
- Exclusive for Cst structure

Block Diagram

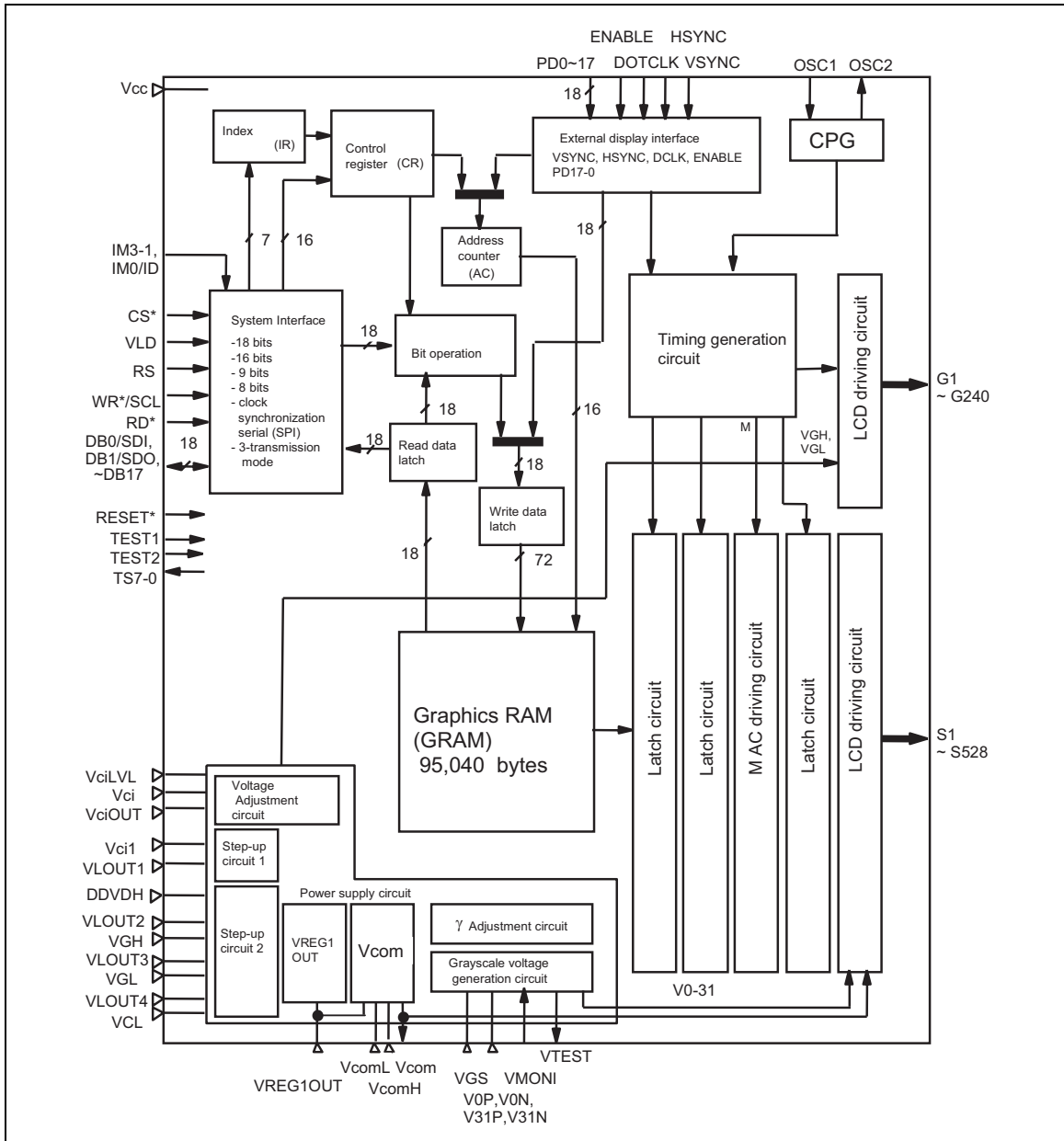

Pin Functions

Signals	Number of Pins	I/O	Connected to	Functions																																																																								
IM3~1, IM0/ID	4	I	GND or IOVcc	<p>Pins to select interfacing mode with MPU.</p> <table border="1"> <thead> <tr> <th>IM3</th> <th>IM2</th> <th>IM1</th> <th>IM0/ID</th> <th>MPU-Interface Mode</th> <th>DB Pin</th> </tr> </thead> <tbody> <tr> <td>GND</td> <td>GND</td> <td>GND</td> <td>GND</td> <td>Setting disabled</td> <td>_</td> </tr> <tr> <td>GND</td> <td>GND</td> <td>GND</td> <td>IOVcc</td> <td>Setting disabled</td> <td>_</td> </tr> <tr> <td>GND</td> <td>GND</td> <td>IOVcc</td> <td>GND</td> <td>80-system 16-bit interface</td> <td>DB17~10, DB8~1</td> </tr> <tr> <td>GND</td> <td>GND</td> <td>IOVcc</td> <td>IOVcc</td> <td>80-system 8-bit interface</td> <td>DB17 ~10</td> </tr> <tr> <td>GND</td> <td>IOVcc</td> <td>GND</td> <td>ID</td> <td>Serial Peripheral Interface (SPI)</td> <td>DB1~ 0</td> </tr> <tr> <td>GND</td> <td>IOVcc</td> <td>IOVcc</td> <td>*</td> <td>Setting disabled</td> <td></td> </tr> <tr> <td>IOVcc</td> <td>GND</td> <td>GND</td> <td>GND</td> <td>Setting disabled</td> <td></td> </tr> <tr> <td>IOVcc</td> <td>GND</td> <td>GND</td> <td>IOVcc</td> <td>Setting disabled</td> <td></td> </tr> <tr> <td>IOVcc</td> <td>GND</td> <td>IOVcc</td> <td>GND</td> <td>80-system 18-bit interface</td> <td>DB17~0</td> </tr> <tr> <td>IOVcc</td> <td>GND</td> <td>IOVcc</td> <td>IOVcc</td> <td>80-system 9-bit interface</td> <td>DB17~9</td> </tr> <tr> <td>IOVcc</td> <td>IOVcc</td> <td>*</td> <td>*</td> <td>Setting disabled</td> <td></td> </tr> </tbody> </table> <p>When Serial Peripheral Interface is selected, IM0 pin is used for the device code ID setting.</p>	IM3	IM2	IM1	IM0/ID	MPU-Interface Mode	DB Pin	GND	GND	GND	GND	Setting disabled	_	GND	GND	GND	IOVcc	Setting disabled	_	GND	GND	IOVcc	GND	80-system 16-bit interface	DB17~10, DB8~1	GND	GND	IOVcc	IOVcc	80-system 8-bit interface	DB17 ~10	GND	IOVcc	GND	ID	Serial Peripheral Interface (SPI)	DB1~ 0	GND	IOVcc	IOVcc	*	Setting disabled		IOVcc	GND	GND	GND	Setting disabled		IOVcc	GND	GND	IOVcc	Setting disabled		IOVcc	GND	IOVcc	GND	80-system 18-bit interface	DB17~0	IOVcc	GND	IOVcc	IOVcc	80-system 9-bit interface	DB17~9	IOVcc	IOVcc	*	*	Setting disabled	
IM3	IM2	IM1	IM0/ID	MPU-Interface Mode	DB Pin																																																																							
GND	GND	GND	GND	Setting disabled	_																																																																							
GND	GND	GND	IOVcc	Setting disabled	_																																																																							
GND	GND	IOVcc	GND	80-system 16-bit interface	DB17~10, DB8~1																																																																							
GND	GND	IOVcc	IOVcc	80-system 8-bit interface	DB17 ~10																																																																							
GND	IOVcc	GND	ID	Serial Peripheral Interface (SPI)	DB1~ 0																																																																							
GND	IOVcc	IOVcc	*	Setting disabled																																																																								
IOVcc	GND	GND	GND	Setting disabled																																																																								
IOVcc	GND	GND	IOVcc	Setting disabled																																																																								
IOVcc	GND	IOVcc	GND	80-system 18-bit interface	DB17~0																																																																							
IOVcc	GND	IOVcc	IOVcc	80-system 9-bit interface	DB17~9																																																																							
IOVcc	IOVcc	*	*	Setting disabled																																																																								
CS*	1	I	MPU	<p>Select the HD66789.</p> <p>Low: the HD6678 is selected and accessible</p> <p>High: the HD66789 is not selected and not accessible</p> <p>Must be fixed to the GND level while not used.</p>																																																																								
VLD	1	I	MPU	<p>Indicate whether the data is valid or not during RAM write.</p> <p>Low: Valid (Write data to RAM)</p> <p>High: Invalid (Not write data to RAM)</p> <p>RAM address will be updated irrespective of VLD.</p> <p>Must be fixed to the GND level while not used.</p> <p>This signal is available when external display interface is used.</p> <table border="1"> <thead> <tr> <th>CS</th> <th>VLD</th> <th>RAM Write</th> <th>RAM Address</th> </tr> </thead> <tbody> <tr> <td>0</td> <td>0</td> <td>Valid</td> <td>Updated</td> </tr> <tr> <td>0</td> <td>1</td> <td>Invalid</td> <td>Updated</td> </tr> <tr> <td>1</td> <td>*</td> <td>Invalid</td> <td>Hold</td> </tr> </tbody> </table>	CS	VLD	RAM Write	RAM Address	0	0	Valid	Updated	0	1	Invalid	Updated	1	*	Invalid	Hold																																																								
CS	VLD	RAM Write	RAM Address																																																																									
0	0	Valid	Updated																																																																									
0	1	Invalid	Updated																																																																									
1	*	Invalid	Hold																																																																									



Signals	Number of Pins	I/O	Connected to	Functions
RS	1	I	MPU	Select register. Low: Index/status, High: Control Fix to the "IOVcc" or "GND" level while using SPI.
WR*/SCL	1	I	MPU	In 80-system bus interface mode, serves as a write strobe signal. Data are written at "Low" level. In Serial Peripheral Interface mode, serves as synchronizing clock signal.
RD*	1	I	MPU	In 80-system bus interface mode, serves as read-strobe signal. Data are read at the low level of the signal. Fix to the "IOVcc" or "GND" level while using SPI.
DB0/SDI	1	I/O	MPU	18-bit parallel bi-directional data bus. 8-bit bus: DB17-DB10 9-bit bus: DB17-DB9 16-bit bus: DB17-DB10 and DB8-DB1 18-bit bus: DB17-DB0 Unused pins must be fixed to the IOVcc or GND level. Serves as serial data input pin (SDI) in Serial Peripheral Interface mode, where data are input on the rising edge of SCL signal.
DB1/SDO	1	I/O	MPU	18-bit parallel bi-directional data bus. 8-bit bus: DB17-DB10 9-bit bus: DB17-DB9 16-bit bus: DB17-DB10 and DB8-DB1 18-bit bus: DB17-DB0 Unused pins must be fixed to the IOVcc or GND level. Serves as serial data output pin (SDO) in Serial Peripheral Interface mode, where data are output on the falling edge of the SCL signal.
DB2~DB17	16	I/O	MPU	18-bit parallel bi-directional data bus. 8-bit bus: DB17-DB10 9-bit bus: DB17-DB9 16-bit bus: DB17-DB10 and DB8-DB1 18-bit bus: DB17-DB0 Unused pins must be fixed to the IOVcc or GND level.
ENABLE	1	I	MPU	Indicate whether RAM data are valid or not when RGB interface is used. Low: Selected (access enabled) High: Not selected (access disabled) Must be fixed to the IOVcc or GND level when not used. ENABLE signal invert the polarity according to the setting of EPL resistor.

Signals	Number of Pins	I/O	Connected to	Functions																																			
ENABLE	1	I	MPU	<table border="1"> <thead> <tr> <th>EPL</th> <th>ENABLE</th> <th>VLD</th> <th>RAM Write</th> <th>RAM Address</th> </tr> </thead> <tbody> <tr> <td>0</td> <td>0</td> <td>0</td> <td>Valid</td> <td>Updated</td> </tr> <tr> <td>0</td> <td>0</td> <td>1</td> <td>Invalid</td> <td>Updated</td> </tr> <tr> <td>0</td> <td>1</td> <td>*</td> <td>Invalid</td> <td>Held</td> </tr> <tr> <td>1</td> <td>0</td> <td>*</td> <td>Invalid</td> <td>Held</td> </tr> <tr> <td>1</td> <td>1</td> <td>0</td> <td>Valid</td> <td>Updated</td> </tr> <tr> <td>1</td> <td>1</td> <td>1</td> <td>Invalid</td> <td>Updated</td> </tr> </tbody> </table>	EPL	ENABLE	VLD	RAM Write	RAM Address	0	0	0	Valid	Updated	0	0	1	Invalid	Updated	0	1	*	Invalid	Held	1	0	*	Invalid	Held	1	1	0	Valid	Updated	1	1	1	Invalid	Updated
EPL	ENABLE	VLD	RAM Write	RAM Address																																			
0	0	0	Valid	Updated																																			
0	0	1	Invalid	Updated																																			
0	1	*	Invalid	Held																																			
1	0	*	Invalid	Held																																			
1	1	0	Valid	Updated																																			
1	1	1	Invalid	Updated																																			
VSYNC	1	I	MPU	Frame synchronizing signal. This signal is active low. Must be fixed at the IOVcc level while not used.																																			
HSYNC	1	I	MPU	Line synchronizing signal. This signal is active low. Must be fixed at the IOVcc level while not used.																																			
DOTCLK	1	I	MPU	Dot-clock signal. This signal is active low. The timing of data input is determined at the falling edge of the signal. Must be fixed at the IOVcc level while not used.																																			
PD0~PD17	18	I	MPU	18-bit bus for RGB data. 6-bit bus: PD17-PD12 16-bit bus: PD17-PD13 and PD11-PD1 18-bit bus: PD17-PD0 Fix unused pins to the IOVcc or GND level.																																			
RESET*	1	I	MPU or reset circuit	Reset pin. Initializes the LSI at the "Low" level. Power-on reset required after turning on the power.																																			
S1~S528	528	O	Liquid Crystal	Output voltage applied to liquid crystal. The shift direction of segment signals is changeable with SS bit. For example, if SS = 0, RAM address "0000" is output from S1. If SS = 1, it is output from S528. S1, S4, S7, ... display red (R), S2, S5, S8, ... display green (G), and S3, S6, S9, ... display blue (B) (SS = 0).																																			
G1~G240	240	O	Liquid Crystal	Gate output signals. When gate lines are selected, VGH signals are output. When gate lines are not selected, VGL are output.																																			
Vcom1, Vcom2	2	O	TFT common electrode	Power supply for TFT common electrode. When Vcom AC drive is not selected, the same level of voltage as VcomL level is output. When Vcom AC drive is selected, the voltage with the amplitude between VcomH and VcomL is output. The AC frequency can be set by the M signal. Connect to the TFT common electrode.																																			

Signals	Number of Pins	I/O	Connected to	Functions
VcomR	1	I	Variable resistor or open	Reference voltage for VcomH. When adjusting VcomH externally, VcomH internal adjusting circuit must be halted by register setting and place a variable resistor between VREG1OUT and GND to make an adjustment. Otherwise, leave open and adjust VcomH by internal register setting.
VcomH	1	O	Stabilizing capacitor	High level of Vcom during Vcom AC drive. Connect to a stabilizing capacitor.
VcomL	1	O	Stabilizing capacitor or open	Vcom voltage when Vcom AC drive is not selected. Low level of Vcom during Vcom AC drive. Voltage can be adjusted with internal registers. Connect to a stabilizing capacitor. When VCOMG bit is set to LOW, a stabilizing capacitor is not necessary because VcomL output is halted.
C11+, C11-	2	-	Step-up capacitor	Step-up capacitor connection pins for step-up circuit 1. When the internal step-up circuit is not used, leave open.
C12+, C12- C21+, C21- C22+, C22-	6	-	Step-up capacitor	Step-up capacitor connection pins for step-up circuit 2. Capacitor connection will be necessary depending on the step-up scale. When the internal step-up circuit is not used, leave open.
OSC1, OSC2	2	I or O	Resistor for the oscillator	Connect an external resistor for R-C oscillation. When supplying clock signals externally, it must be supplied through OSC1 and leave OSC2 open.
FLM	1	O	MPU or open	Frame head pulse with amplitude between GND and Vcc. Use when writing data to RAM in synchronization with FLM. When FLM is not used, leave open.
Vci	1	I	Power supply	Power supply for analogue circuits. In this case, a power supply for the VciOUT amplifier. Connect an external power supply of 2.5~3.3V.
VciLVL	1	I	Power supply	Generates a reference voltage (VciOUT, REGP) in accordance to the ratio set with VC2~0 registers. Connect to the same power supply as the Vci, which has separate wiring from the VciLVL on the FPC.
REGP	1	I/O	Test pin	Test pin for VREG1OUT. Leave open.
VciOUT	1	I	Stabilizing capacitor, Vci1	Internal reference voltage with amplitude between Vci and GND. Set with VC bit.
Vci1	1	I	VciOUT	Reference voltage for the step-up circuit 1. Connect to an external power supply of 2.75V or less when the internal reference voltage is not used.
VLOUT1	1	O	Stabilizing capacitor, DDVDH	Output twice stepped-up Vci1 voltage from the step-up circuit 1. Connect to a stabilizing capacitor. VLOUT1 = 4.0~5.5V
DDVDH	1	I	VLOUT1	Power supply for source driver liquid crystal output portion. A reference voltage for the step-up circuit 2.

Signals	Number of Pins	I/O	Connected to	Functions
VLOUT2	1	O	Stabilizing capacitor, VGH	Output stepped-up DDVDH voltage, which is stepped up to the level $V_{ci1} \times 4\sim 6$ from the step-up circuit 2. The step-up scale is determined with BT bits. Connect to a stabilizing capacitor. $VLOUT2 = \max 16.5V$
VGH	1	I	VLOUT2	Power supply for TFT gate drive. Connect to VLOUT2.
VLOUT3	1	O	Stabilizing capacitor, VGL	Output stepped-up DDVDH voltage, which is stepped up to the level $V_{ci1} \times (-3) \sim (-5)$ from the step-up circuit 2. The step-up scale is determined with BT bits. Connect to a stabilizing capacitor. $VLOUT2 = \min -16.5V$
VGL	1	I	VLOUT3	Power supply for TFT gate drive. Connect to VLOUT3.
VLOUT4	1	O	Stabilizing capacitor, VCL	Output the $V_{ci1} \times (-1)$ voltage from the step-up circuit 2. Connect to a stabilizing capacitor. $VLOUT4 = 0 \sim -3.3V$
VCL	1	I	VLOUT4	Power supply for $V_{comL}$ drive. Connect to VLOUT4.
VREG1OUT	1	I/O	Stabilizing capacitor or power supply	Reference voltage with amplitude between DDVDH and GND, which is generated from the reference voltage internally generated with amplitudes between $V_{ci}$ and GND. The scale of the output voltage can be set with VRH bits. VREG1OUT becomes (1) a source driver grayscale reference voltage $VDH$ , (2) a $V_{comH}$ level reference voltage, or (3) a $V_{com}$ amplitude reference voltage. Connect to a stabilizing capacitor. $VREG1OUT = 3.0 \sim (DDVDH - 0.5)V$
Vcc	1	-	Power supply	Power supply for a logic circuit. $V_{cc} = 2.4\sim 3.3V$
IOVcc	1	-	Power supply	Power supply for interface pins. $IOV_{cc} = 1.8\sim 3.3V$ . $IOV_{cc}$ must be turned on with the same voltage as the internal logic voltage $V_{cc}$ . When it is assembled on COG, connect to $V_{cc}$ on the FPC to avoid effects from the noise when $IOV_{cc}$ is used.
RVcc	1	-	Power supply	$V_{cc}$ power supply for RAM. Supply with the same potential as the $V_{cc}$ .
GND	1	-	Power supply	Ground for the logic side. $GND = 0V$
AGND	1	-	Power supply	Ground for the analog side. $AGND = 0V$ . When assembled on COG, connect to GND on the FPC to avoid effects from the noise.
RGND	1	-	Power supply	Ground for internal RAM. $RGND = 0V$ . When assembled on COG, connect to GND on the FPC to avoid effects from the noise.
CGND	1	O	Opposing GND for external parts	GND level output. Available as an opposing GND for external parts (capacitors, diodes).
TEST1	1	I	GND	Test pin. Fix it to the GND level.
TEST2	1	I	GND	Test pin. Fix it to the GND level.

Signals	Number of Pins	I/O	Connected to	Functions
V0P, V31P	2	I or O	Stabilizing capacitor	Output from internal positive polarity operational amplifier when the operational amplifier is ON (SAP2-0 = "001", "010", "011", "100", and "101"). Stabilize by connecting to a capacitor.
V0N, V31N	2	I or O	Stabilizing capacitor	Output from internal negative polarity operational amplifier when the operational amplifier is ON (SAP2-0 = "001", "010", "011", "100", and "101"). Stabilize by connecting to a capacitor.
VGS	1	I	GND or external resistor	Reference level for grayscale voltage generation circuit. Connect to an external resistor when source driver is used to adjust grayscale levels for each panel.
VTESTS	1	I/O	open	Test pin. Leave open.
TS0~TS7	8	O	open	Test pin. Leave open.
TESTA1	1	I/O	open	Test pin for VcomH. Leave open.
TESTA2	1	I/O	open	Test pin for VcomL. Leave open.
TESTA4	1	I/O	open	Test pin for VcomL. Leave open or connect to a stabilizing capacitor depending on the display quality.
VMONI	1	O	open	Test pin. Leave open.
IOVccDUM1~4	4	O	Input pin	Internal IOVcc level. When neighboring input pins are fixed to the IOVcc side, short-circuit them.
IOGNDUM1~7	7	O	Input pin	Internal GND level. When neighboring input pins are fixed to the IOVcc side, short-circuit them.
TESTO1~2	2	-	-	Dummy pads. Leave open.
DUMMY		-	-	Dummy pad. Leave open.
DUMMYR		-	-	Dummy pad. Leave open.

PAD arrangement

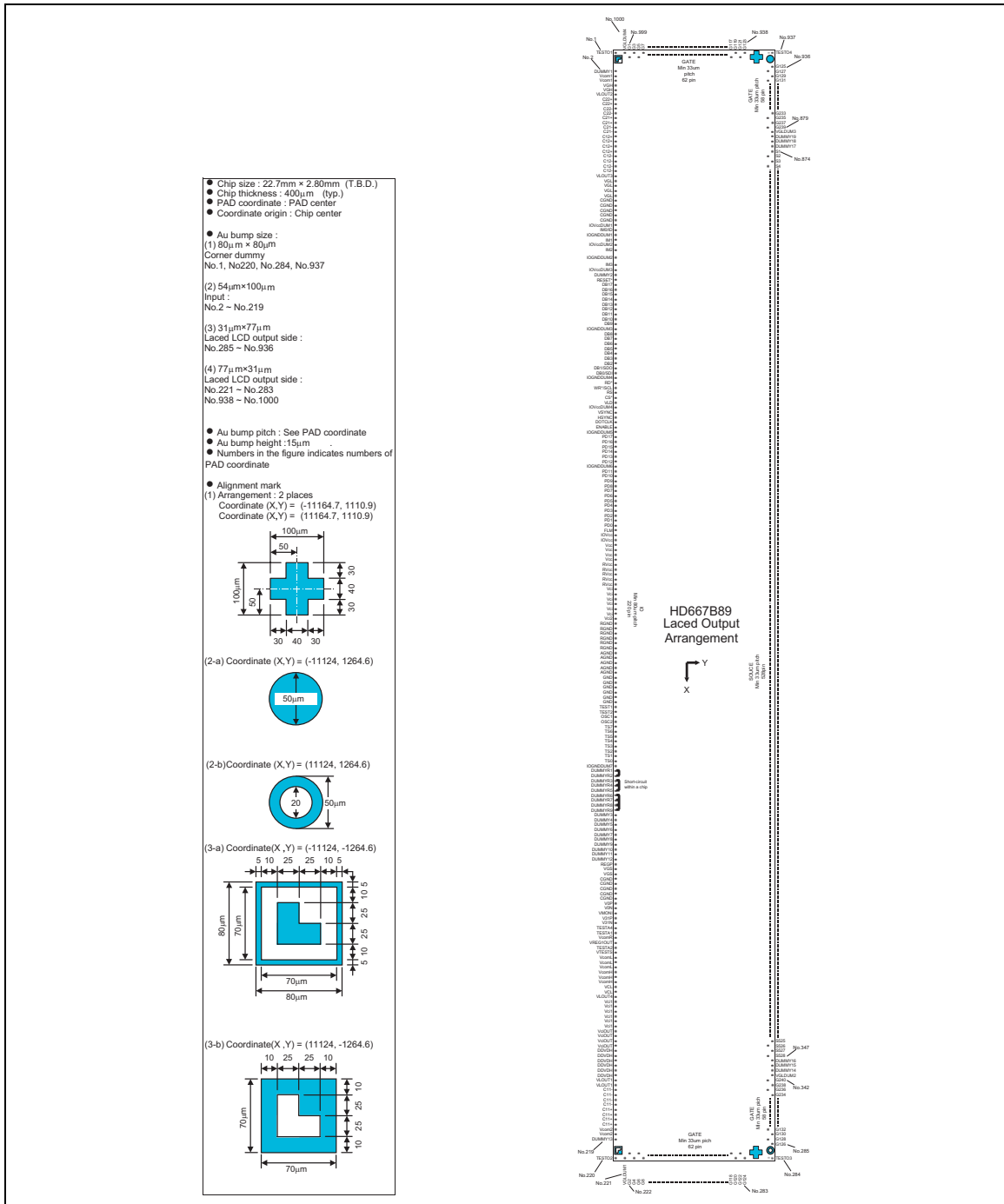

PAD Coordinate

Pad No.	pad name	X	Y	Pad No.	pad name	X	Y	Pad No.	pad name	X	Y	Pad No.	pad name	X	Y
1	DUMM1	-1121.0	-1254.0	131	TEST12	1759.4	-1254.0	261	S80	1121.5	239.3	391	S484	727.5	1148.0
2	DUMM2	-1088.2	-1254.0	132	TEST13	1769.4	-1254.0	262	S82	1109.5	272.4	392	S483	744.4	1265.0
3	Vcom1	-1070.2	-1254.0	133	OSC1	1889.0	-1254.0	263	S84	1121.5	305.5	393	S482	721.3	1148.0
4	Vcom2	-1070.2	-1254.0	134	OSC2	1979.2	-1254.0	264	S86	1109.5	338.5	394	S481	717.2	1265.0
5	VGH	-1059.1	-1254.0	135	TS1	219.8	-1254.0	265	S88	1121.5	371.6	395	S480	714.2	1148.0
6	VGH	-1049.0	-1254.0	136	TS6	219.0	-1254.0	266	S90	1109.5	404.7	396	S479	712.1	1265.0
7	VLDUT2	-1038.5	-1254.0	137	TS5	227.1	-1254.0	267	S92	1121.5	437.8	397	S478	707.0	1148.0
8	C2*	-1027.4	-1254.0	138	TS4	233.9	-1254.0	268	S94	1109.5	470.9	398	S477	704.9	1265.0
9	C2*	-1014.2	-1254.0	139	TS3	243.4	-1254.0	269	S96	1121.5	503.9	399	S476	701.9	1148.0
10	C2*	-1007.1	-1254.0	140	TS2	251.9	-1254.0	270	S98	1109.5	537.0	400	S475	697.8	1265.0
11	C2*	-998.8	-1254.0	141	OSC1	259.3	-1254.0	271	G100	1121.5	570.1	401	S474	694.7	1148.0
12	C1*	-990.8	-1254.0	142	TS0	267.9	-1254.0	272	G102	1109.5	603.1	402	S473	691.6	1265.0
13	C1*	-982.8	-1254.0	143	OSC1	275.3	-1254.0	273	G104	1121.5	636.1	403	S472	688.5	1148.0
14	C1*	-974.5	-1254.0	144	DUMMYR1	282.4	-1254.0	274	G106	1109.5	669.1	404	S471	685.4	1265.0
15	C1*	-966.3	-1254.0	145	DUMMYR2	304.6	-1254.0	275	G108	1121.5	702.4	405	S470	682.4	1148.0
16	C1*	-957.9	-1254.0	146	DUMMYR3	314.8	-1254.0	276	G110	1109.5	735.4	406	S469	679.3	1265.0
17	C1*	-944.7	-1254.0	147	DUMMYR4	324.9	-1254.0	277	G112	1121.5	768.5	407	S468	676.3	1148.0
18	C1*	-936.6	-1254.0	148	DUMMYR5	335.1	-1254.0	278	G114	1109.5	801.6	408	S467	673.2	1265.0
19	C1*	-927.4	-1254.0	149	DUMMYR6	335.2	-1254.0	279	G116	1121.5	834.7	409	S466	670.1	1148.0
20	C1*	-914.0	-1254.0	150	DUMMYR7	345.4	-1254.0	280	G118	1109.5	867.7	410	S465	667.0	1265.0
21	C1*	-906.8	-1254.0	151	DUMMYR8	354.5	-1254.0	281	G120	1121.5	900.8	411	S464	663.9	1148.0
22	C1*	-898.7	-1254.0	152	DUMMYR9	362.7	-1254.0	282	G122	1109.5	933.9	412	S463	660.8	1265.0
23	C1*	-890.6	-1254.0	153	DUMMY10	370.8	-1254.0	283	G124	1121.5	967.0	413	S462	657.7	1148.0
24	VLDUT3	-871.6	-1254.0	154	DUMMY11	378.9	-1254.0	284	TEST103	1121.0	1000.0	414	S461	654.6	1265.0
25	VGL	-864.2	-1254.0	155	DUMMY12	386.1	-1254.0	285	G126	1109.5	1033.1	415	S460	651.5	1148.0
26	VGL	-856.4	-1254.0	156	DUMMY13	394.2	-1254.0	286	G128	1121.5	1066.1	416	S459	648.4	1265.0
27	VGL	-848.2	-1254.0	157	DUMMY14	402.4	-1254.0	287	G130	1109.5	1099.1	417	S458	645.3	1148.0
28	VGL	-840.2	-1254.0	158	DUMMY15	406.6	-1254.0	288	G132	1121.5	1132.1	418	S457	642.2	1265.0
29	CND	-829.1	-1254.0	159	DUMMY16	416.9	-1254.0	289	G134	1109.5	1165.1	419	S456	639.1	1148.0
30	CND	-818.0	-1254.0	160	CUMD10	426.9	-1254.0	290	G136	1121.5	1198.1	420	S455	636.0	1265.0
31	CND	-810.8	-1254.0	161	DUMMY17	437.0	-1254.0	291	G138	1109.5	1231.1	421	S454	632.9	1148.0
32	CND	-802.7	-1254.0	162	DUMMY18	447.2	-1254.0	292	G140	1121.5	1264.1	422	S453	629.8	1265.0
33	CND	-794.5	-1254.0	163	RECP	457.4	-1254.0	293	G142	1109.5	1297.1	423	S452	626.7	1148.0
34	IOVDDUM1	-781.5	-1254.0	164	IOVDDUM1	457.4	-1254.0	294	G144	1121.5	1330.1	424	S451	623.6	1265.0
35	IOVDD	-769.2	-1254.0	165	IOVDD	467.3	-1254.0	295	G146	1109.5	1363.1	425	S450	620.5	1148.0
36	IOVDDUM2	-753.7	-1254.0	166	IOVDD	477.2	-1254.0	296	G148	1121.5	1396.1	426	S449	617.4	1265.0
37	IM1	-743.4	-1254.0	167	CND	507.8	-1254.0	297	G150	1109.5	1429.1	427	S448	614.3	1148.0
38	IOVDDUM2	-729.1	-1254.0	168	CND	517.9	-1254.0	298	G152	1121.5	1462.1	428	S447	611.2	1265.0
39	IM2	-714.6	-1254.0	169	CND	528.1	-1254.0	299	G154	1109.5	1495.1	429	S446	608.1	1148.0
40	IOVDDUM2	-703.1	-1254.0	170	CND	538.2	-1254.0	300	G156	1121.5	1528.1	430	S445	605.0	1265.0
41	IM3	-691.2	-1254.0	171	VDD	548.3	-1254.0	301	G158	1109.5	1561.1	431	S444	601.9	1148.0
42	IOVDDUM3	-678.3	-1254.0	172	VDD	568.3	-1254.0	302	G160	1121.5	1594.1	432	S443	598.8	1265.0
43	IOVDDUM2	-663.3	-1254.0	173	VDD	574.1	-1254.0	303	G162	1109.5	1627.1	433	S442	595.7	1148.0
44	RESET*	-651.2	-1254.0	174	V31P	580.0	-1254.0	304	G164	1121.5	1660.1	434	S441	592.6	1265.0
45	DB17	-637.9	-1254.0	175	V31N	585.9	-1254.0	305	G166	1109.5	1693.1	435	S440	589.5	1148.0
46	DB18	-629.7	-1254.0	176	TESTA4	613.5	-1254.0	306	G168	1121.5	1726.1	436	S439	586.4	1265.0
47	DB15	-621.8	-1254.0	177	VDD	641.8	-1254.0	307	G170	1109.5	1759.1	437	S438	583.3	1148.0
48	DB14	-613.4	-1254.0	178	VDD	654.0	-1254.0	308	G172	1121.5	1792.1	438	S437	580.2	1265.0
49	DB13	-605.3	-1254.0	179	REGOUT	669.9	-1254.0	309	G174	1109.5	1825.1	439	S436	577.1	1148.0
50	DB12	-597.1	-1254.0	180	REGOUT	675.7	-1254.0	310	G176	1121.5	1858.1	440	S435	574.0	1265.0
51	DB11	-589.0	-1254.0	181	TESTS1	691.5	-1254.0	311	G178	1109.5	1891.1	441	S434	570.9	1148.0
52	DB10	-581.1	-1254.0	182	VDD	701.1	-1254.0	312	G180	1121.5	1924.1	442	S433	567.8	1265.0
53	DB9	-573.1	-1254.0	183	VDD	724.7	-1254.0	313	G182	1109.5	1957.1	443	S432	564.7	1148.0
54	IOVDDUM3	-558.7	-1254.0	184	VDD	742.2	-1254.0	314	G184	1121.5	1990.1	444	S431	561.6	1265.0
55	DB8	-549.9	-1254.0	185	VDD	757.1	-1254.0	315	G186	1109.5	2023.1	445	S430	558.5	1148.0
56	DB7	-538.7	-1254.0	186	VDD	759.6	-1254.0	316	G188	1121.5	2056.1	446	S429	555.4	1265.0
57	DB6	-530.6	-1254.0	187	VDD	769.1	-1254.0	317	G190	1109.5	2089.1	447	S428	552.3	1148.0
58	DB5	-520.4	-1254.0	188	VDD	807.4	-1254.0	318	G192	1121.5	2122.1	448	S427	549.2	1265.0
59	DB4	-514.3	-1254.0	189	VDD	819.3	-1254.0	319	G194	1109.5	2155.1	449	S426	546.1	1148.0
60	DB3	-508.1	-1254.0	190	VDD	829.4	-1254.0	320	G196	1121.5	2188.1	450	S425	543.0	1265.0
61	DB2	-498.0	-1254.0	191	VDD	838.9	-1254.0	321	G198	1109.5	2221.1	451	S424	539.9	1148.0
62	DB1	-490.8	-1254.0	192	VDD	849.0	-1254.0	322	G200	1121.5	2254.1	452	S423	536.8	1265.0
63	IOVDDUM3	-482.8	-1254.0	193	VDD	859.2	-1254.0	323	G202	1109.5	2287.1	453	S422	533.7	1148.0
64	IOVDDUM4	-468.4	-1254.0	194	VDD	869.3	-1254.0	324	G204	1121.5	2320.1	454	S421	530.6	1265.0
65	IOVDD	-458.6	-1254.0	195	VDD	879.4	-1254.0	325	G206	1109.5	2353.1	455	S420	527.5	1148.0
66	WRP/SC1	-448.7	-1254.0	196	VDD	879.9	-1254.0	326	G208	1121.5	2386.1	456	S419	524.4	1265.0
67	RS	-440.6	-1254.0	197	VDD	884.9	-1254.0	327	G210	1109.5	2419.1	457	S418	521.3	1148.0
68	CS	-432.8	-1254.0	198	VDD	892.9	-1254.0	328	G212	1121.5	2452.1	458	S417	518.2	1265.0
69	VLD1	-424.8	-1254.0	199	VDD	901.1	-1254.0	329	G214	1109.5	2485.1	459	S416	515.1	1148.0
70	VLD2	-411.8	-1254.0	200	VDD	906.2	-1254.0	330	G216	1121.5	2518.1	460	S415	512.0	1265.0
71	VLD3	-398.4	-1254.0	201	VDD	924.1	-1254.0	331	G218	1109.5	2551.1	461	S414	508.9	1148.0
72	HSYNC	-394.3	-1254.0	202	VDD	934.2	-1254.0	332	VDD	940.9	2584.1	462	S413	505.8	1265.0
73	IOVDDUM1	-382.4	-1254.0	203	VDD	938.4	-1254.0	333	G220	1121.5	2617.1	463	S412	502.7	1148.0
74	ENABLE	-374.0	-1254.0	204	VDD	947.5	-1254.0	334	G222	1109.5	2650.1	464	S411	499.6	1265.0
75	IOVDDUM2	-359.6	-1254.0	205	VDD	954.7	-1254.0	335	G224	1121.5	2683.1	465	S410	496.5	1148.0
76	PD17	-349.2	-1254.0	206	VDD	963.8	-1254.0	336	G226	1109.5	2716.1	466	S409	493.4	1265.0
77	PD16	-340.1	-1254.0	207	VDD	973.8	-1254.0	337	G228	1121.5	2749.1	467	S408	490.3	1148.0
78	PD15	-331.8	-1254.0	208	VDD	983.8	-1254.0	338	G230	1109.5	2782.1	468	S407	487.2	1265.0
79	PD14	-324.1	-1254.0	209	VDD	1000.7	-1254.0	339	G232	1121.5	2815.1	469	S406	484.1	1148.0
80	PD13	-316.1	-1254.0	210	VDD	1002.2	-1254.0	340	G234	1109.5	2848.1	470	S405	481.0	1265.0

part no.	part name	x	y	part no.	part name	x	y	part no.	part name	x	y	part no.	part name	x	y
521 S254	2977.7	1148.5	651 S224	-1357.0	1148.5	781 S94	-5556.9	1148.5	911 S175	-10131.5	1148.5				
522 S253	2944.6	1265.5	652 S223	-1390.1	1265.5	782 S93	-5689.9	1265.5	912 S174	-10164.6	1265.5				
523 S252	2911.6	1148.5	653 S222	-1423.2	1148.5	783 S92	-5722.9	1148.5	913 S173	-10197.7	1148.5				
524 S251	2878.5	1265.5	654 S221	-1456.3	1265.5	784 S91	-5756.0	1265.5	914 G169	-10230.8	1265.5				
525 S250	2845.4	1148.5	655 S220	-1489.3	1148.5	785 S90	-5789.1	1148.5	915 G168	-10263.9	1148.5				
526 S249	2812.4	1265.5	656 S219	-1522.4	1265.5	786 S89	-5822.2	1265.5	916 G167	-10297.0	1265.5				
527 S248	2779.3	1148.5	657 S218	-1555.5	1148.5	787 S88	-5855.3	1148.5	917 G166	-10330.1	1148.5				
528 S247	2746.3	1265.5	658 S217	-1588.6	1265.5	788 S87	-5888.4	1265.5	918 S165	-10363.2	1265.5				
529 S246	2713.2	1148.5	659 S216	-1621.7	1148.5	789 S86	-5921.5	1148.5	919 G159	-10396.3	1148.5				
530 S245	2680.2	1265.5	660 S215	-1654.8	1265.5	790 S85	-5954.6	1265.5	920 G158	-10429.4	1265.5				
531 S244	2647.1	1148.5	661 S214	-1687.9	1148.5	791 S84	-5987.7	1148.5	921 G157	-10462.5	1148.5				
532 S243	2614.1	1265.5	662 S213	-1721.0	1265.5	792 S83	-6020.8	1265.5	922 G156	-10495.6	1265.5				
533 S242	2581.0	1148.5	663 S212	-1754.1	1148.5	793 S82	-6053.9	1148.5	923 G155	-10528.7	1148.5				
534 S241	2547.9	1265.5	664 S211	-1787.2	1265.5	794 S81	-6087.0	1265.5	924 G149	-10561.8	1265.5				
535 S240	2514.9	1148.5	665 S210	-1820.3	1148.5	795 S80	-6120.1	1148.5	925 G148	-10594.9	1148.5				
536 S239	2481.8	1265.5	666 S209	-1853.4	1265.5	796 S79	-6153.2	1265.5	926 G147	-10628.0	1265.5				
537 S238	2448.8	1148.5	667 S208	-1886.5	1148.5	797 S78	-6186.3	1148.5	927 G146	-10661.1	1148.5				
538 S237	2415.7	1265.5	668 S207	-1919.6	1265.5	798 S77	-6219.4	1265.5	928 G145	-10694.2	1265.5				
539 S236	2382.7	1148.5	669 S206	-1952.7	1148.5	799 S76	-6252.5	1148.5	929 G139	-10727.3	1148.5				
540 S235	2349.6	1265.5	670 S205	-1985.8	1265.5	800 S75	-6285.6	1265.5	930 G138	-10760.4	1265.5				
541 S234	2316.6	1148.5	671 S204	-2018.9	1148.5	801 S74	-6318.7	1148.5	931 G137	-10793.5	1148.5				
542 S233	2283.5	1265.5	672 S203	-2052.0	1265.5	802 S73	-6351.8	1265.5	932 G136	-10826.6	1148.5				
543 S232	2250.5	1148.5	673 S202	-2085.1	1148.5	803 S72	-6384.9	1148.5	933 G135	-10859.7	1148.5				
544 S231	2217.4	1265.5	674 S201	-2118.2	1265.5	804 S71	-6418.0	1265.5	934 G129	-10892.8	1265.5				
545 S230	2184.4	1148.5	675 S200	-2151.3	1148.5	805 S70	-6451.1	1148.5	935 G128	-10925.9	1265.5				
546 S229	2151.3	1265.5	676 S199	-2184.4	1265.5	806 S69	-6484.2	1265.5	936 G127	-10959.0	1265.5				
547 S228	2118.3	1148.5	677 S198	-2217.5	1148.5	807 S68	-6517.3	1148.5	937 TEST04	-11214.0	1264.0				
548 S227	2085.2	1265.5	678 S197	-2250.6	1265.5	808 S67	-6550.4	1265.5	938 G121	-11247.1	907.0				
549 S226	2052.2	1148.5	679 S196	-2283.7	1148.5	809 S66	-6583.5	1148.5	939 G120	-11280.2	908.0				
550 S225	2019.1	1265.5	680 S195	-2316.8	1265.5	810 S65	-6616.6	1265.5	940 G119	-11313.3	909.0				
551 S224	1986.1	1148.5	681 S194	-2349.9	1148.5	811 S64	-6649.7	1148.5	941 G117	-11346.4	907.0				
552 S223	1953.0	1265.5	682 S193	-2383.0	1265.5	812 S63	-6682.8	1265.5	942 G115	-11379.5	804.0				
553 S222	1920.0	1148.5	683 S192	-2416.1	1148.5	813 S62	-6715.9	1148.5	943 G113	-11412.6	910.0				
554 S221	1886.9	1265.5	684 S191	-2449.2	1265.5	814 S61	-6749.0	1265.5	944 G111	-11445.7	788.0				
555 S220	1853.9	1148.5	685 S190	-2482.3	1148.5	815 S60	-6782.1	1148.5	945 G109	-11478.8	814.0				
556 S219	1820.8	1265.5	686 S189	-2515.4	1265.5	816 S59	-6815.2	1265.5	946 G107	-11511.9	702.0				
557 S218	1787.8	1148.5	687 S188	-2548.5	1148.5	817 S58	-6848.3	1148.5	947 G105	-11545.0	689.0				
558 S217	1754.7	1265.5	688 S187	-2581.6	1265.5	818 S57	-6881.4	1265.5	948 G103	-11578.1	603.0				
559 S216	1721.7	1148.5	689 S186	-2614.7	1148.5	819 S56	-6914.5	1148.5	949 G101	-11611.2	603.0				
560 S215	1688.6	1265.5	690 S185	-2647.8	1265.5	820 S55	-6947.6	1265.5	950 G99	-11644.3	608.0				
561 S214	1655.6	1148.5	691 S184	-2680.9	1148.5	821 S54	-6980.7	1148.5	951 G97	-11677.4	537.0				
562 S213	1622.5	1265.5	692 S183	-2714.0	1265.5	822 S53	-7013.8	1265.5	952 G95	-11710.5	503.0				
563 S212	1589.5	1148.5	693 S182	-2747.1	1148.5	823 S52	-7046.9	1148.5	953 G93	-11743.6	419.0				
564 S211	1556.4	1265.5	694 S181	-2780.2	1265.5	824 S51	-7080.0	1265.5	954 G91	-11776.7	437.0				
565 S210	1523.4	1148.5	695 S180	-2813.3	1148.5	825 S50	-7113.1	1148.5	955 G89	-11809.8	353.0				
566 S209	1490.3	1265.5	696 S179	-2846.4	1265.5	826 S49	-7146.2	1265.5	956 G87	-11842.9	371.0				
567 S208	1457.3	1148.5	697 S178	-2879.5	1148.5	827 S48	-7179.3	1148.5	957 G85	-11876.0	335.0				
568 S207	1424.2	1265.5	698 S177	-2912.6	1265.5	828 S47	-7212.4	1265.5	958 G83	-11909.1	251.0				
569 S206	1391.2	1148.5	699 S176	-2945.7	1148.5	829 S46	-7245.5	1148.5	959 G81	-11942.2	272.0				
570 S205	1358.1	1265.5	700 S175	-2978.8	1265.5	830 S45	-7278.6	1265.5	960 G79	-11975.3	293.0				
571 S204	1325.1	1148.5	701 S174	-3011.9	1148.5	831 S44	-7311.7	1148.5	961 G77	-12008.4	208.0				
572 S203	1292.0	1265.5	702 S173	-3045.0	1265.5	832 S43	-7344.8	1265.5	962 G75	-12041.5	173.0				
573 S202	1259.0	1148.5	703 S172	-3078.1	1148.5	833 S42	-7377.9	1148.5	963 G73	-12074.6	150.0				
574 S201	1225.9	1265.5	704 S171	-3111.2	1265.5	834 S41	-7411.0	1265.5	964 G71	-12107.7	107.0				
575 S200	1192.9	1148.5	705 S170	-3144.3	1148.5	835 S40	-7444.1	1148.5	965 G69	-12140.8	73.0				
576 S199	1159.8	1265.5	706 S169	-3177.4	1265.5	836 S39	-7477.2	1265.5	966 G67	-12173.9	40.0				
577 S198	1126.8	1148.5	707 S168	-3210.5	1148.5	837 S38	-7510.3	1148.5	967 G65	-12207.0	7.0				
578 S197	1093.7	1265.5	708 S167	-3243.6	1265.5	838 S37	-7543.4	1265.5	968 G63	-12240.1	34.0				
579 S196	1060.7	1148.5	709 S166	-3276.7	1148.5	839 S36	-7576.5	1148.5	969 G61	-12273.2	58.0				
580 S195	1027.6	1265.5	710 S165	-3309.8	1265.5	840 S35	-7609.6	1265.5	970 G59	-12306.3	91.0				
581 S194	994.6	1148.5	711 S164	-3342.9	1148.5	841 S34	-7642.7	1148.5	971 G57	-12339.4	124.0				
582 S193	961.5	1265.5	712 S163	-3376.0	1265.5	842 S33	-7675.8	1265.5	972 G55	-12372.5	157.0				
583 S192	928.5	1148.5	713 S162	-3409.1	1148.5	843 S32	-7708.9	1148.5	973 G53	-12405.6	190.0				
584 S191	895.4	1265.5	714 S161	-3442.2	1265.5	844 S31	-7742.0	1265.5	974 G51	-12438.7	223.0				
585 S190	862.4	1148.5	715 S160	-3475.3	1148.5	845 S30	-7775.1	1148.5	975 G49	-12471.8	256.0				
586 S189	829.3	1265.5	716 S159	-3508.4	1265.5	846 S29	-7808.2	1265.5	976 G47	-12504.9	389.0				
587 S188	796.3	1148.5	717 S158	-3541.5	1148.5	847 S28	-7841.3	1148.5	977 G45	-12538.0	322.0				
588 S187	763.2	1265.5	718 S157	-3574.6	1265.5	848 S27	-7874.4	1148.5	978 G43	-12571.1	355.0				
589 S186	730.2	1148.5	719 S156	-3607.7	1148.5	849 S26	-7907.5	1148.5	979 G41	-12604.2	388.0				
590 S185	697.1	1265.5	720 S155	-3640.8	1265.5	850 S25	-7940.6	1265.5	980 G39	-12637.3	421.0				
591 S184	664.1	1148.5	721 S154	-3673.9	1148.5	851 S24	-7973.7	1148.5	981 G37	-12670.4	454.0				
592 S183	631.0	1265.5	722 S153	-3707.0	1265.5	852 S23	-8006.8	1265.5	982 G35	-12703.5	487.0				
593 S182	598.0	1148.5	723 S152	-3740.1	1148.5	853 S22	-8039.9	1148.5	983 G33	-12736.6	520.0				
594 S181	564.9	1265.5	724 S151	-3773.2	1265.5	854 S21	-8073.0	1265.5	984 G31	-12769.7	553.0				
595 S180	531.9	1148.5	725 S150	-3806.3	1148.5	855 S20	-8106.1	1148.5	985 G29	-12802.8	586.0				
596 S179	498.8	1265.5	726 S149	-3839.4	1265.5	856 S19	-8139.2	1148.5	986 G27	-12835.9	619.0				
597 S178	465.8	1148.5	727 S148	-3872.5	1148.5	857 S18	-8172.3	1148.5	987 G25	-12869.0	652.0				
598 S177	432.7	1265.5	728 S147	-3905.6	1265.5	858 S17	-8205.4	1265.5	988 G23	-12902.1	685.0				
599 S176	399.7	1148.5	729 S146	-3938.7	1148.5	859 S16	-8238.5	1148.5	989 G21	-12935.2	718.0				
600 S175	366.6	1265.5	730 S145	-3971.8	1265.5	860 S15	-8271.6	1265.5	990 G19	-12968.3	751.0				
601 S174	333.6	1148.5	731 S144	-4004.9	1148.5	861 S14	-8304.7	1148.5	991 G17	-13001.4	784.0				
602 S173	300.5	1265.5	732 S143	-4038.0	1265.5	862 S13	-8337.8	1265.5	992 G15	-13034.5	817.0				
603 S172	267.5	1148.5	733 S142	-4071.1	1148.5	863 S12	-8370.9	1148.5	993 G13	-13067.6	850.0				
604 S171	234.4	1265.5	734 S141	-4104.2	1265.5	864 S11	-8404.0	1265.5	994 G11	-13100.7	883.0				
605 S170	201.4	1148.5	735 S140	-4137.3	1148.5	865 S10	-8437.1	1148.5	995 G09	-13133.8	916.0				
606 S209	168.3	1265.5	736 S139	-4170.4	1265.5	866 S09	-8470.2	1265.5	996 G07	-13166.9	949.0				
607 S208	135.3	1148.5	737 S138	-4203.5	1148.5	867 S08	-8503.3	1148.5	997 G05	-13200.0	982.0				
608 S															

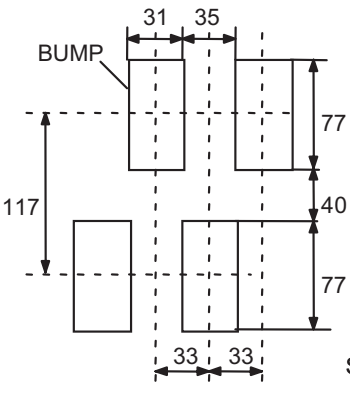
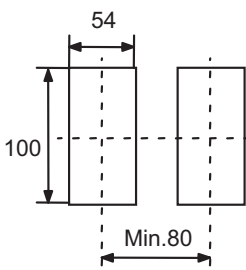
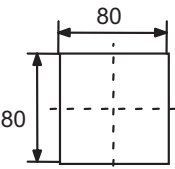

**BUMP Arrangements**

<p>S1 ~ S528 G1 ~ G240</p>	 <p><math>S=2387\mu\text{m}^2</math> Unit: <math>\mu\text{m}</math></p>
<p>I/O pins</p>	 <p><math>S=5400\mu\text{m}^2</math> Unit: <math>\mu\text{m}</math></p>
<p>TESTO1 ~ 4</p>	 <p><math>S=6400\mu\text{m}^2</math> Unit: <math>\mu\text{m}</math></p>

## Block Function

### 1. System Interface

The HD66789 has five high-speed system interfaces: 80-system 18-/16-/9-/8-bit bus and Serial Peripheral Interface (SPI) port. The interface mode is selected with IM3-0 pins.

The HD66789 has three registers: 16-bit index register (IR), 18-bit write-data register (WDR), and 18-bit read-data register (RDR). The IR stores index information from control registers and GRAM. The WDR temporarily stores data to write into the control registers and GRAM, and the RDR temporarily stores data read from GRAM. Data written into GRAM from the MPU is first written into the WDR and then automatically written into GRAM by internal operation. Since data are read through the RDR from GRAM, the data read out first are invalid data and the ensuing data are read out normally.

The execution time for instructions other than oscillation start is 0-clock cycle, which enables consecutively writing instructions.

#### Register Selection (8/9/16/18 Parallel Interfaces)

##### 80-system Bus

WR*	RD*	RS	Operation
0	1	0	Write index to IR
1	0	0	Read internal status
0	1	1	Write to the control registers or GRAM through WDR
1	0	1	Read from GRAM through RDR

#### Values of CS and VLD during RAM Write

CS*	VLD	Operations
0	0	Write data to GRAM. RAM address is updated.
1	0	Not write data to GRAM. RAM address is not updated.
0	1	Not write data to GRAM. RAM address is updated.
1	1	Not write data to GRAM. RAM address is not updated.

Note 1) The VLD setting is only effective with RAM write instructions.

#### Register Selection (Serial Peripheral Interface)

##### Start bytes

R/W	RS	Operations
0	0	Write index to IR
1	0	Read internal status
0	1	Write into control register and GRAM through WDR
1	1	Read from GRAM through RDR

## 2. External Display Interface

The HD66789 incorporates RGB and VSYNC interfaces as an external interface for displaying moving pictures. When RGB-I/F is selected, the display operation is executed in synchronization with the externally supplied signals, VSYNC, HSYNC, and DOTCLK. The display data (PD17-0) are written according to the values of the data enable signal (ENABLE) and data valid signal (VLD) in synchronization with VSYNC, HSYNC, and DOTCLK signals. This data write method allows flicker-free screen update. When VSYNC-I/F is selected, operations other than the frame synchronization by VSYNC signal are synchronized with internal clocks. The display data are written to GRAM through a system interface. In this case, there are constraints on the timing and methods of RAM update. See the “External Display Interface” section for more details.

Switching between conventional system interfaces and external display interfaces is made through instructions. An optimum interface is selected whether the screen is displaying moving or still pictures. All data written through RGB-I/F are written to GRAM. Therefore, data is transmitted only when the screen is being updated, which reduces the amount of data transmission, thereby saving power when moving pictures are being displayed.

## 3. Bit Operations

The HD66789 supports a write data mask function that selects and writes data into GRAM by bit, and performs logical operation or conditional rewrite on the contents of compare registers and the data to write to GRAM. For details, see the “Graphics Operation Functions” section.

## 4. Address Counter (AC)

The address counter (AC) assigns address to GRAM. When an address set instruction is written into the IR, the address information is sent from the IR to the AC.

After writing data into GRAM, the AC is automatically updated plus or minus 1. The AC is not updated when the data are read from GRAM. Window address function enables data write only in the rectangular area of GRAM specified by the window address.

## 5. Graphics RAM (GRAM)

GRAM is a graphics RAM that stores bit-pattern data of 176 x 240 bytes with 18 bits per pixel.

## 6. Gray scale power supply voltage generating circuit

The grayscale voltage generation circuit generates liquid crystal drive voltage according to the grayscale data set in the  $\gamma$ -correction register, enabling 262,144-color display. For details, see the “ $\gamma$ -Correction Register” section.

## 7. Timing Generator

The timing generator generates timing signals for the operation of internal circuits such as GRAM. The timing for display operation such as RAM read and the internal operation timing such as access from MPU are generated in a way to avoid mutual interfere. The interface signals (M, FLM, CL1, EQ, DCCLK,

DISPTMG, and SFTCLK) are generated internally, and a part of the signals is output through a level transforming circuit.

### **8. Oscillation Circuit (OSC)**

The HD66789 can provide R-C oscillation simply by placing an external oscillation-resistor between OSC1 and OSC2 pins. An appropriate oscillation frequency for operating voltage, display size, and frame frequency can be obtained by adjusting the external-resistor value. Clock pulses can be supplied externally. Since R-C oscillation is halted during the standby mode, current consumption will be reduced. For details, see the "Oscillation Circuit" section.

### **9. LCD Driver Circuit**

The LCD driver circuit of HD66789 consists of a 528-output source driver (S1 ~ S528) and a 240-output gate driver (G1 ~ G240). Display pattern data are latched when 528-bit data arrive. The latched data controls source driver and generates drive waveforms. The gate driver, which operates display scan, selects either VGH or VGL level to output. The shift direction of outputting 528 bits from source driver is changeable with the SS bit. The shift direction of gate driver scan is changeable with the GS bit. The scan mode of gate driver is changeable with SM bit. Select an appropriate shift direction and mode for an assembly.

### **10. Liquid crystal drive power supply circuit**

The LCD drive power supply circuit of HD66789 generates voltage, V0, V31P, V31N, VGH, and Vcom required for driving LCD.

GRAM Address MAP

SG pin		S1	S2	S3	S4	S5	S6	S7	S8	S9	S10	S11	S12	.....	S517	S518	S519	S520	S521	S522	S523	S524	S525	S526	S527	S528
GS=0	GS=1	PD 17 ... 0	PD 17 ... 0	PD 17 ... 0	PD 17 ... 0	PD 17 ... 0	PD 17 ... 0	PD 17 ... 0	PD 17 ... 0	PD 17 ... 0	PD 17 ... 0	PD 17 ... 0	PD 17 ... 0	PD 17 ... 0	PD 17 ... 0	PD 17 ... 0	PD 17 ... 0	PD 17 ... 0	PD 17 ... 0	PD 17 ... 0	PD 17 ... 0	PD 17 ... 0	PD 17 ... 0	PD 17 ... 0	PD 17 ... 0	PD 17 ... 0
G1	G240	"0000"	"0001"	"0002"	"0003"	.....	"00AC"	"00AD"	"00AE"	"00AF"																
G2	G239	"0100"	"0101"	"0102"	"0103"	.....	"01AC"	"01AD"	"01AE"	"01AF"																
G3	G238	"0200"	"0201"	"0202"	"0203"	.....	"02AC"	"02AD"	"02AE"	"02AF"																
G4	G237	"0300"	"0301"	"0302"	"0303"	.....	"03AC"	"03AD"	"03AE"	"03AF"																
G5	G236	"0400"	"0401"	"0402"	"0403"	.....	"04AC"	"04AD"	"04AE"	"04AF"																
G6	G235	"0500"	"0501"	"0502"	"0503"	.....	"05AC"	"05AD"	"05AE"	"05AF"																
G7	G234	"0600"	"0601"	"0602"	"0603"	.....	"06AC"	"06AD"	"06AE"	"06AF"																
G8	G233	"0700"	"0701"	"0702"	"0703"	.....	"07AC"	"07AD"	"07AE"	"07AF"																
G9	G232	"0800"	"0801"	"0802"	"0803"	.....	"08AC"	"08AD"	"08AE"	"08AF"																
G10	G231	"0900"	"0901"	"0902"	"0903"	.....	"09AC"	"09AD"	"09AE"	"09AF"																
G11	G230	"0A00"	"0A01"	"0A02"	"0A03"	.....	"0AAC"	"0AAD"	"0AAE"	"0AAF"																
G12	G229	"0B00"	"0B01"	"0B02"	"0B03"	.....	"0BAC"	"0BAD"	"0BAE"	"0BAF"																
G13	G228	"0C00"	"0C01"	"0C02"	"0C03"	.....	"0CAC"	"0CAD"	"0CAE"	"0CAF"																
G14	G227	"0D00"	"0D01"	"0D02"	"0D03"	.....	"0DAC"	"0DAD"	"0DAE"	"0DAF"																
G15	G226	"0E00"	"0E01"	"0E02"	"0E03"	.....	"0EAC"	"0EAD"	"0EAE"	"0EAF"																
G16	G225	"0F00"	"0F01"	"0F02"	"0F03"	.....	"0FAC"	"0FAD"	"0FAE"	"0FAF"																
G17	G224	"1000"	"1001"	"1002"	"1003"	.....	"10AC"	"10AD"	"10AE"	"10AF"																
G18	G223	"1100"	"1101"	"1102"	"1103"	.....	"11AC"	"11AD"	"11AE"	"11AF"																
G19	G222	"1200"	"1201"	"1202"	"1203"	.....	"12AC"	"12AD"	"12AE"	"12AF"																
G20	G221	"1300"	"1301"	"1302"	"1303"	.....	"13AC"	"13AD"	"13AE"	"13AF"																
...	...	...	...	...	...	.....	.....	.....	.....	.....																
G233	G8	"0800"	"0801"	"0802"	"0803"	.....	"E8AC"	"E8AD"	"E8AE"	"E8AF"																
G234	G7	"0900"	"0901"	"0902"	"0903"	.....	"E9AC"	"E9AD"	"E9AE"	"E9AF"																
G235	G6	"EA00"	"EA01"	"EA02"	"EA03"	.....	"EAAC"	"EAAD"	"EAAE"	"EAAF"																
G236	G5	"EB00"	"EB01"	"EB02"	"EB03"	.....	"EBAC"	"EBAD"	"EBAE"	"EBAF"																
G237	G4	"EC00"	"EC01"	"EC02"	"EC03"	.....	"ECAC"	"ECAD"	"ECAE"	"ECAF"																
G238	G3	"ED00"	"ED01"	"ED02"	"ED03"	.....	"EDAC"	"EDAD"	"EDAE"	"EDAF"																
G239	G2	"EE00"	"EE01"	"EE02"	"EE03"	.....	"EEAC"	"EEAD"	"EEAE"	"EEAF"																
G240	G1	"EF00"	"EF01"	"EF02"	"EF03"	.....	"EFAC"	"EFAD"	"EFAE"	"EFAF"																

GRAM address and display panel position (SS = '0')

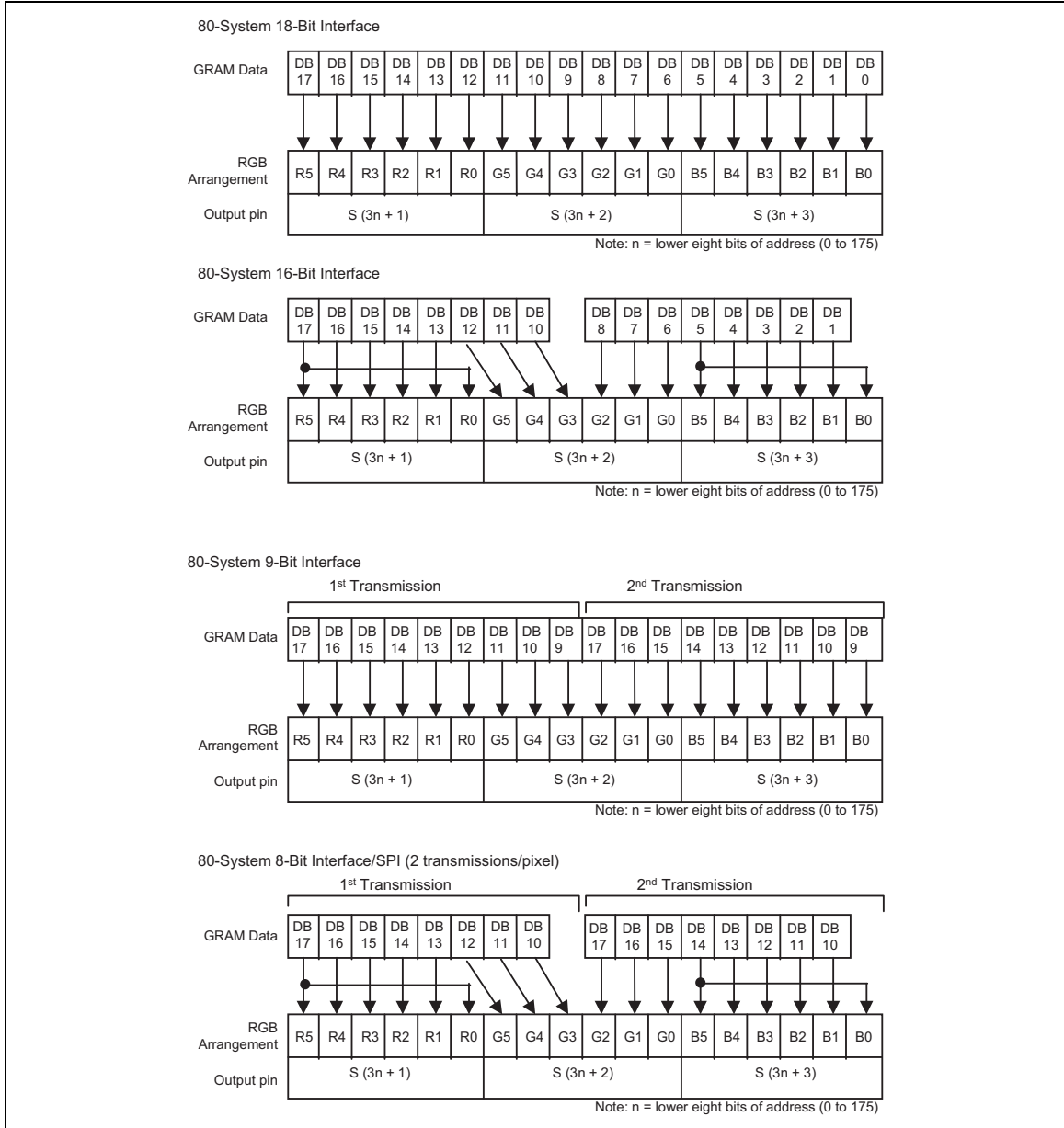

**GRAM data and RGB assignment (SS = "0", BGR = "0")**

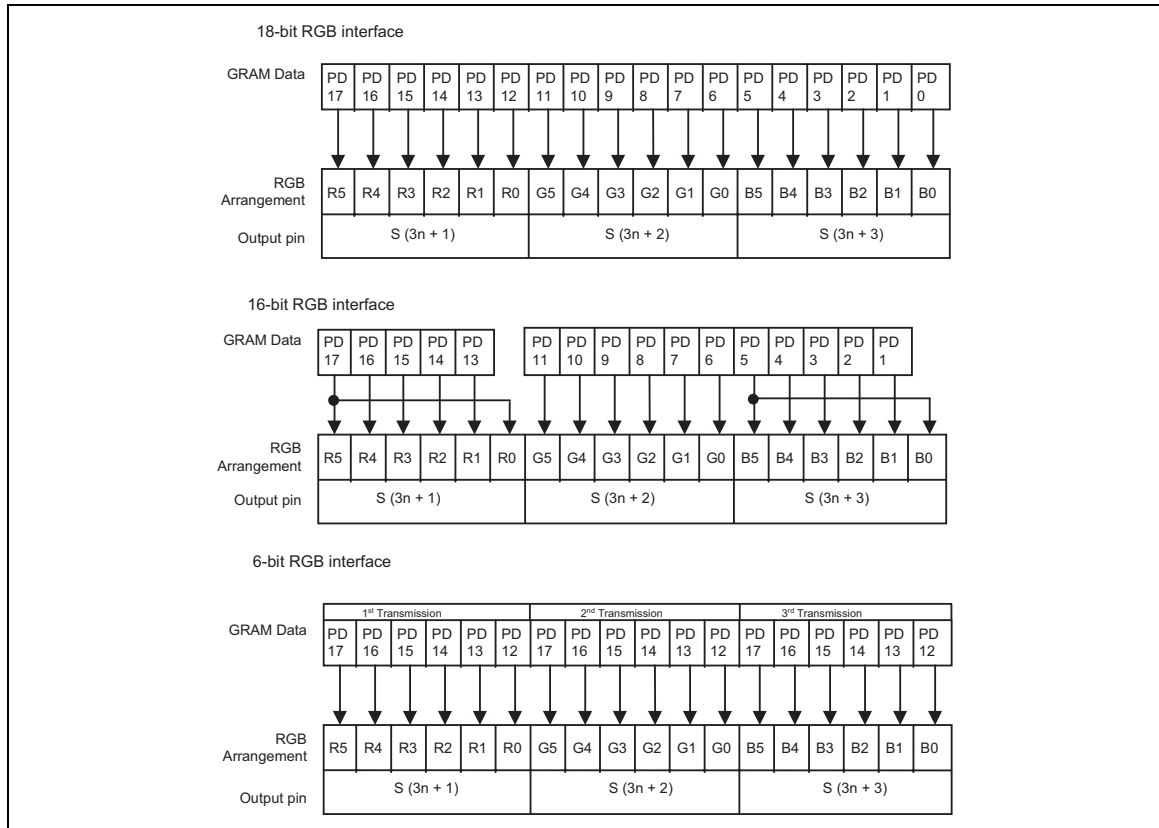

**GRAM data and RGB assignment (SS = "0", BGR = "0")**

SG pin		S1	S2	S3	S4	S5	S6	S7	S8	S9	S10	S11	S12	.....	S517	S518	S519	S520	S521	S522	S523	S524	S525	S526	S527	S528
GS=0	GS=1	PD 17 ... 0	PD 17 ... 0	PD 17 ... 0	PD 17 ... 0	PD 17 ... 0	PD 17 ... 0	PD 17 ... 0	PD 17 ... 0	PD 17 ... 0	PD 17 ... 0	PD 17 ... 0	PD 17 ... 0	PD 17 ... 0	PD 17 ... 0	PD 17 ... 0	PD 17 ... 0	PD 17 ... 0	PD 17 ... 0	PD 17 ... 0	PD 17 ... 0	PD 17 ... 0	PD 17 ... 0	PD 17 ... 0	PD 17 ... 0	PD 17 ... 0
G1	G240	"00AF"H	"00AE"H	"00AD"H	"00AC"H	.....	.....	.....	.....	.....	.....	.....	.....	.....	"0003"H	"0002"H	"0001"H	"0000"H	.....	.....	.....	.....	.....	.....	.....	.....
G2	G239	"01AF"H	"01AE"H	"01AD"H	"01AC"H	.....	.....	.....	.....	.....	.....	.....	.....	.....	"0103"H	"0102"H	"0101"H	"0100"H	.....	.....	.....	.....	.....	.....	.....	.....
G3	G238	"02AF"H	"02AE"H	"02AD"H	"02AC"H	.....	.....	.....	.....	.....	.....	.....	.....	.....	"0203"H	"0202"H	"0201"H	"0200"H	.....	.....	.....	.....	.....	.....	.....	.....
G4	G237	"03AF"H	"03AE"H	"03AD"H	"03AC"H	.....	.....	.....	.....	.....	.....	.....	.....	.....	"0303"H	"0302"H	"0301"H	"0300"H	.....	.....	.....	.....	.....	.....	.....	.....
G5	G236	"04AF"H	"04AE"H	"04AD"H	"04AC"H	.....	.....	.....	.....	.....	.....	.....	.....	.....	"0403"H	"0402"H	"0401"H	"0400"H	.....	.....	.....	.....	.....	.....	.....	.....
G6	G235	"05AF"H	"05AE"H	"05AD"H	"05AC"H	.....	.....	.....	.....	.....	.....	.....	.....	.....	"0503"H	"0502"H	"0501"H	"0500"H	.....	.....	.....	.....	.....	.....	.....	.....
G7	G234	"06AF"H	"06AE"H	"06AD"H	"06AC"H	.....	.....	.....	.....	.....	.....	.....	.....	.....	"0603"H	"0602"H	"0601"H	"0600"H	.....	.....	.....	.....	.....	.....	.....	.....
G8	G233	"07AF"H	"07AE"H	"07AD"H	"07AC"H	.....	.....	.....	.....	.....	.....	.....	.....	.....	"0703"H	"0702"H	"0701"H	"0700"H	.....	.....	.....	.....	.....	.....	.....	.....
G9	G232	"08AF"H	"08AE"H	"08AD"H	"08AC"H	.....	.....	.....	.....	.....	.....	.....	.....	.....	"0803"H	"0802"H	"0801"H	"0800"H	.....	.....	.....	.....	.....	.....	.....	.....
G10	G231	"09AF"H	"09AE"H	"09AD"H	"09AC"H	.....	.....	.....	.....	.....	.....	.....	.....	.....	"0903"H	"0902"H	"0901"H	"0900"H	.....	.....	.....	.....	.....	.....	.....	.....
G11	G230	"0AAF"H	"0AAE"H	"0AAD"H	"0AAC"H	.....	.....	.....	.....	.....	.....	.....	.....	.....	"0A03"H	"0A02"H	"0A01"H	"0A00"H	.....	.....	.....	.....	.....	.....	.....	.....
G12	G229	"0BAF"H	"0BAE"H	"0BAD"H	"0BAC"H	.....	.....	.....	.....	.....	.....	.....	.....	.....	"0B03"H	"0B02"H	"0B01"H	"0B00"H	.....	.....	.....	.....	.....	.....	.....	.....
G13	G228	"0CAF"H	"0CAE"H	"0CAD"H	"0CAC"H	.....	.....	.....	.....	.....	.....	.....	.....	.....	"0C03"H	"0C02"H	"0C01"H	"0C00"H	.....	.....	.....	.....	.....	.....	.....	.....
G14	G227	"0DAF"H	"0DAE"H	"0DAD"H	"0DAC"H	.....	.....	.....	.....	.....	.....	.....	.....	.....	"0D03"H	"0D02"H	"0D01"H	"0D00"H	.....	.....	.....	.....	.....	.....	.....	.....
G15	G226	"0EAF"H	"0EAE"H	"0EAD"H	"0EAC"H	.....	.....	.....	.....	.....	.....	.....	.....	.....	"0E03"H	"0E02"H	"0E01"H	"0E00"H	.....	.....	.....	.....	.....	.....	.....	.....
G16	G225	"0FAF"H	"0FAE"H	"0FAD"H	"0FAC"H	.....	.....	.....	.....	.....	.....	.....	.....	.....	"0F03"H	"0F02"H	"0F01"H	"0F00"H	.....	.....	.....	.....	.....	.....	.....	.....
G17	G224	"10AF"H	"10AE"H	"10AD"H	"10AC"H	.....	.....	.....	.....	.....	.....	.....	.....	.....	"1003"H	"1002"H	"1001"H	"1000"H	.....	.....	.....	.....	.....	.....	.....	.....
G18	G223	"11AF"H	"11AE"H	"11AD"H	"11AC"H	.....	.....	.....	.....	.....	.....	.....	.....	.....	"1103"H	"1102"H	"1101"H	"1100"H	.....	.....	.....	.....	.....	.....	.....	.....
G19	G222	"12AF"H	"12AE"H	"12AD"H	"12AC"H	.....	.....	.....	.....	.....	.....	.....	.....	.....	"1203"H	"1202"H	"1201"H	"1200"H	.....	.....	.....	.....	.....	.....	.....	.....
G20	G221	"13AF"H	"13AE"H	"13AD"H	"13AC"H	.....	.....	.....	.....	.....	.....	.....	.....	.....	"1303"H	"1302"H	"1301"H	"1300"H	.....	.....	.....	.....	.....	.....	.....	.....
.....	.....	.....	.....	.....	.....	.....	.....	.....	.....	.....	.....	.....	.....	.....	.....	.....	.....	.....	.....	.....	.....	.....	.....	.....	.....	.....
G233	G8	"E8AF"H	"E8AE"H	"E8AD"H	"E8AC"H	.....	.....	.....	.....	.....	.....	.....	.....	.....	"0803"H	"0802"H	"0801"H	"0800"H	.....	.....	.....	.....	.....	.....	.....	.....
G234	G7	"E9AF"H	"E9AE"H	"E9AD"H	"E9AC"H	.....	.....	.....	.....	.....	.....	.....	.....	.....	"0903"H	"0902"H	"0901"H	"0900"H	.....	.....	.....	.....	.....	.....	.....	.....
G235	G6	"EAAF"H	"EAAE"H	"EAAD"H	"EAAC"H	.....	.....	.....	.....	.....	.....	.....	.....	.....	"EA03"H	"EA02"H	"EA01"H	"EA00"H	.....	.....	.....	.....	.....	.....	.....	.....
G236	G5	"EBAF"H	"EBAE"H	"EBAD"H	"EBAC"H	.....	.....	.....	.....	.....	.....	.....	.....	.....	"EB03"H	"EB02"H	"EB01"H	"EB00"H	.....	.....	.....	.....	.....	.....	.....	.....
G237	G4	"ECAF"H	"ECAE"H	"ECAD"H	"ECAC"H	.....	.....	.....	.....	.....	.....	.....	.....	.....	"EC03"H	"EC02"H	"EC01"H	"EC00"H	.....	.....	.....	.....	.....	.....	.....	.....
G238	G3	"EDAF"H	"EDAE"H	"EDAD"H	"EDAC"H	.....	.....	.....	.....	.....	.....	.....	.....	.....	"ED03"H	"ED02"H	"ED01"H	"ED00"H	.....	.....	.....	.....	.....	.....	.....	.....
G239	G2	"EEAF"H	"EEAE"H	"EEAD"H	"EEAC"H	.....	.....	.....	.....	.....	.....	.....	.....	.....	"EE03"H	"EE02"H	"EE01"H	"EE00"H	.....	.....	.....	.....	.....	.....	.....	.....
G240	G1	"EFAF"H	"EFAE"H	"EFAD"H	"EFAC"H	.....	.....	.....	.....	.....	.....	.....	.....	.....	"EF03"H	"EF02"H	"EF01"H	"EF00"H	.....	.....	.....	.....	.....	.....	.....	.....

GRAM address and display panel position (SS ="1", BGR "1")



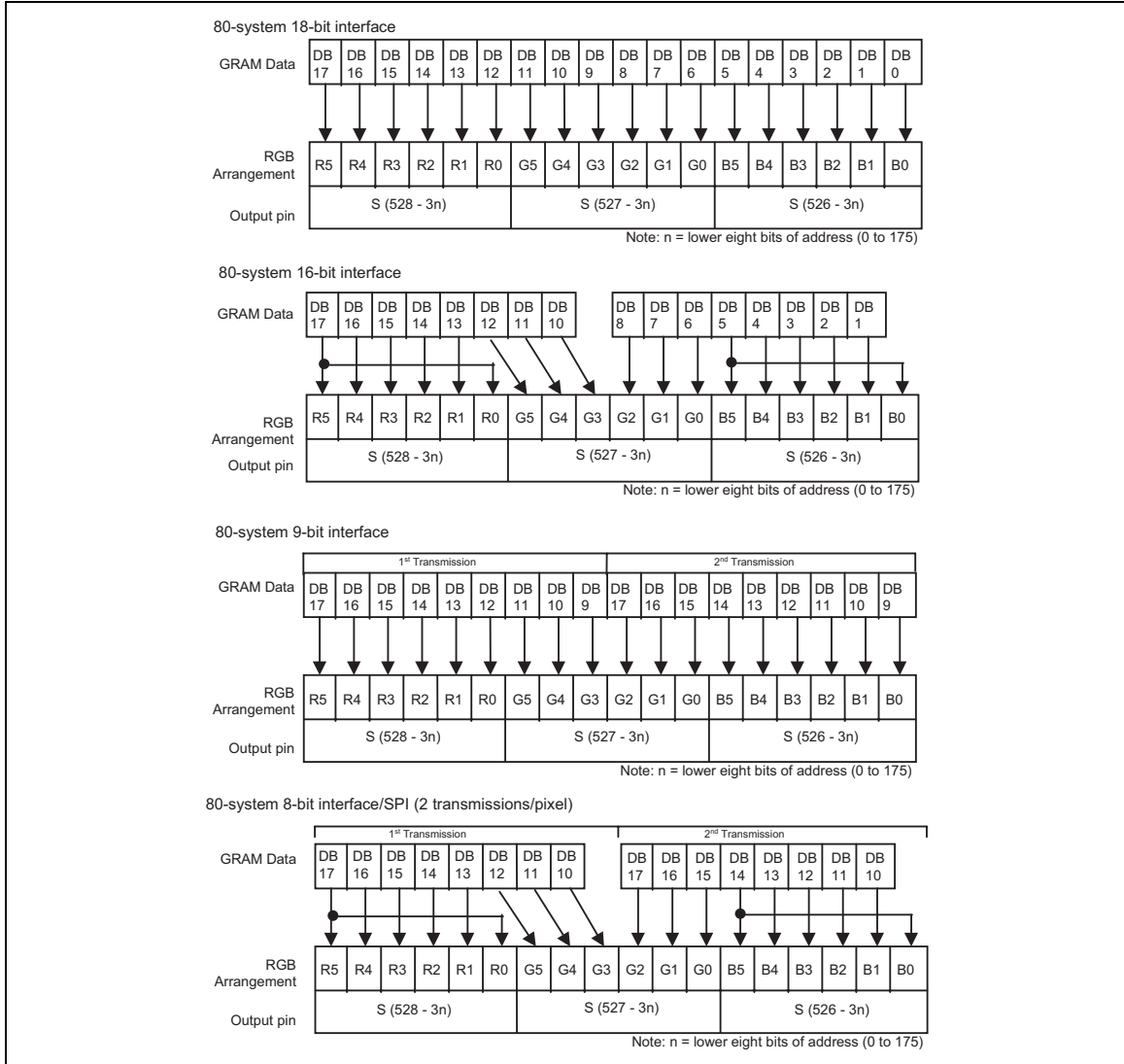

**GRAM data and RGB assignment (SS = "1", BGR = "1")**

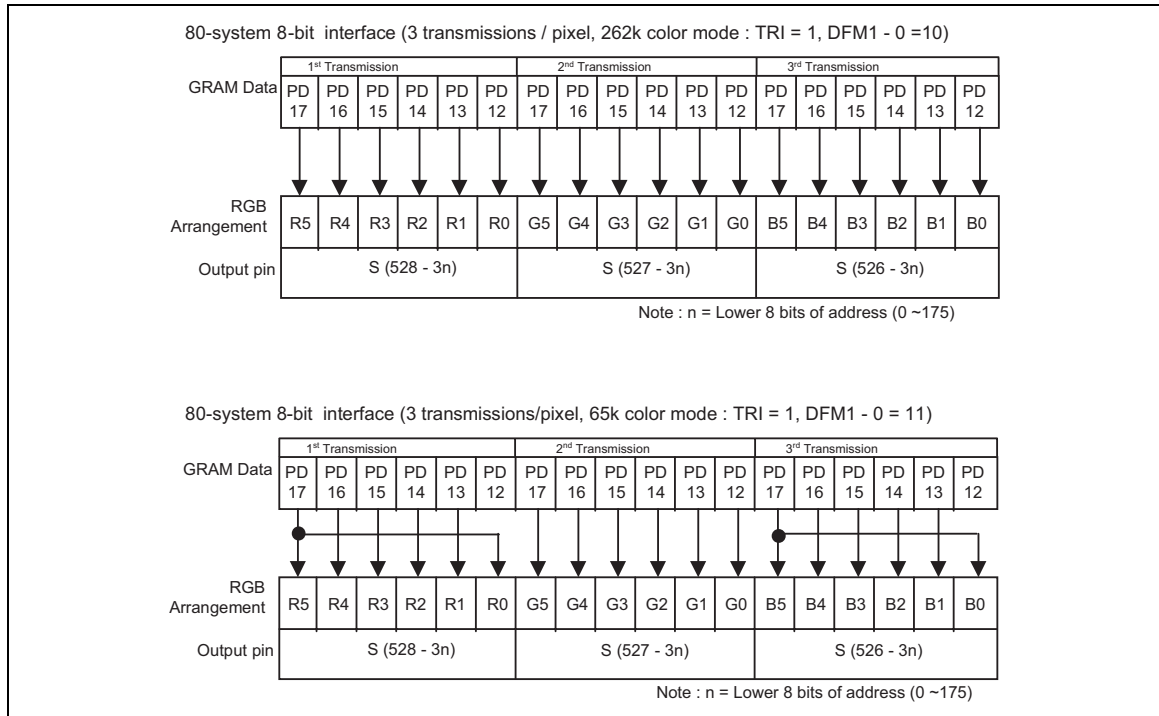

**GRAM data and RGB assignment (SS = "1", BGR = "1")**

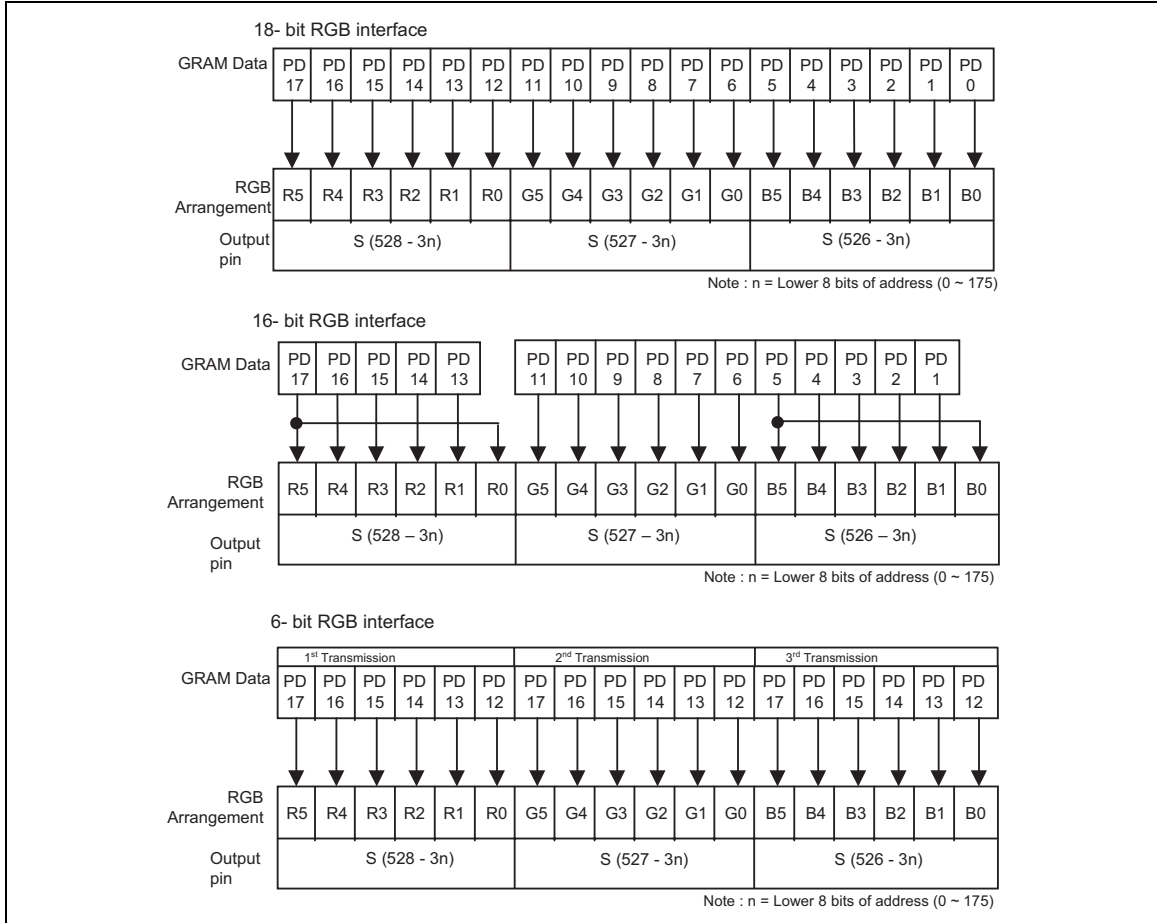

**GRAM data and RGB assignment (SS = "1", BGR = "1")**

## Instructions

### Outline

The HD66789 adapts 18-bit bus architecture that enables high-speed interfacing with a high-performance microcomputer. Data sent from external (18/16/9/8 bits) are stored temporarily in the instruction register (IR) and the data register (DR) to store control information before internal operation starts. Since internal operation is decided according to the signal sent from the microcomputer, register selection signal (RS), read/write signal (R/W), and internal 16-bit data bus signal (DB15 to DB0) are called instruction. GRAM is accessed through internal 18-bit data bus. There are eight categories of instructions:

1. Specify index
2. Read status
3. Control display
4. Control power management
5. Process graphics data
6. Set internal GRAM address
7. Transfer data to and from internal GRAM
8. Set grayscale level for internal grayscale  $\gamma$ -adjustment

Normally, the 7<sup>th</sup> instruction to write display data is executed the most frequently. The address of internal GRAM is updated automatically after data are written to the internal GRAM. With the window address function, this reduces the amount of data transmission to minimum and thereby lightens the load on the program in the microcomputer. Since instructions are executed in 0 cycle, it is possible to write instructions consecutively.

As the following figure shows, the assignment to the 16 instruction bits (IB15-0) varies according to the interface in use. An instruction must adopt the data format for each interface.

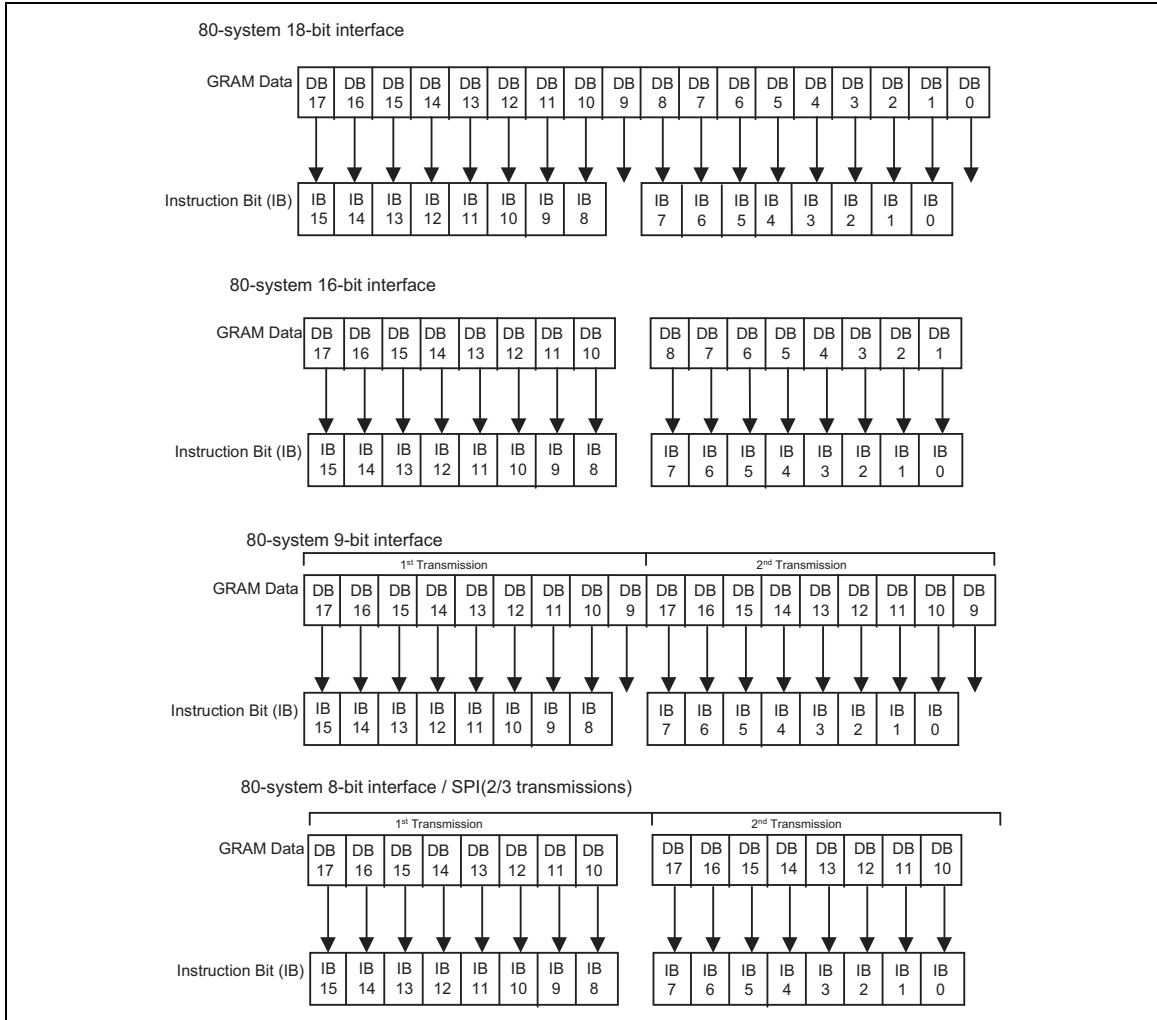

**Instruction bits**

**Instructions**

The following are detail explanations of instructions with illustrations of instruction bits (IB15-0) assigned to each interface.

**Index**

The index instruction specifies the index (R00h to R4Fh) of control register and RAM control. It sets the register number from 0000000 to 1111111 in binary form. Do not try to access to the register to which the index is not assigned.

R/W	RS	IB15	IB14	IB13	IB12	IB11	IB10	IB9	IB8	IB7	IB6	IB5	IB4	IB3	IB2	IB1	IB0
W	0	*	*	*	*	*	*	*	*	*	ID6	ID5	ID4	ID3	ID2	ID1	ID0

**Status Read**

The status read instruction reads the internal status of the HD66789.

**L7-0:** Indicate the position of raster-row driving liquid crystal.

R/W	RS	IB15	IB14	IB13	IB12	IB11	IB10	IB9	IB8	IB7	IB6	IB5	IB4	IB3	IB2	IB1	IB0
R	0	L7	L6	L5	L4	L3	L2	L1	L0	0	0	0	0	0	0	0	0

**Start Oscillation (R00h)**

The start oscillation instruction restarts the oscillator in a halt state during the standby mode. After executing this instruction, wait at least 10 ms for stabilizing oscillation before issuing a next instruction. For details, see the “Standby Mode” section.

“0789”H is read out, if this register is forced to read out.

R/W	RS	IB15	IB14	IB13	IB12	IB11	IB10	IB9	IB8	IB7	IB6	IB5	IB4	IB3	IB2	IB1	IB0
W	1	*	*	*	*	*	*	*	*	*	*	*	*	*	*	*	1
R	1	0	0	0	0	0	1	1	1	1	0	0	0	1	0	0	1

**Driver Output Control (R01h)**

R/W	RS	IB15	IB14	IB13	IB12	IB11	IB10	IB9	IB8	IB7	IB6	IB5	IB4	IB3	IB2	IB1	IB0
W	1	0	VSPL	HSPL	DPL	EPL	SM	GS	SS	0	0	0	NL4	NL3	NL2	NL1	NL0

**SS:** Select the shift direction of outputs from the source driver. When SS = 0, the shift direction of outputs is from S1 to S528. When SS = 1, the shift direction of outputs is from S528 to S1. In addition to the shift direction, the settings for both SS and BGR bits are required to change the assignment of R, G, B dots to the source driver pins. To assign R, G, B dots to the source driver pins interchangeably from S1, set SS = 0, BGR = 0. To assign R, G, B dots to the source driver pins interchangeably from S528, set SS = 1, BGR = 1.

**GS:** Select the shift direction of outputs from the gate driver. The scan order is changeable in accordance to the scan mode by the gate driver. Select an optimum shift direction for the assembly.

**SM:** Set the scan order by the gate driver. Select an optimum scan order for the assembly. For details, see “Scan Mode Setting”.

**EPL:** Set the polarity of ENABLE pin while using the RGB interface.

EPL = "0" : ENABLE = "Low" / Write data to PD17-0.  
   : ENABLE = "High" / Data write invalid.  
 EPL = "1" : ENABLE = "High" / Write data to PD17-0.  
   : ENABLE = "Low" / Data write invalid.

The following table shows the relationship between EPL, ENABLE, VLD and RAM access.

EPL	ENABLE	VLD	RAM write	RAM address
0	0	0	Valid	Updated
0	0	1	Invalid	Updated
0	1	*	Invalid	Hold
1	0	*	Invalid	Hold
1	1	0	Valid	Updated
1	1	1	Invalid	Updated

**VSPL:** Invert the polarity of signal for VSYNC pin.

VSPL = "0" : Low active.  
 VSPL = "1" : High active.

**HSPL:** Invert the polarity of signal for HSYNC pin.

HSPL = "0" : Low active.  
 HSPL = "1" : High active.

**DPL:** Invert the polarity of signal for DOTCLK pin.

DPL = "0" : Data are read in synchronization with the rising edge of the DOTCLK.  
 DPL = "1" : Data are read in synchronization with the falling edge of the DOTCLK.

**NL4-0:** Specify the number of LCD drive raster-rows. The number of drive raster-rows is changeable by 8 multiples. The GRAM address mapping is independent of this setting. Select a number of raster-rows so that the display size covers the size of a panel.

NL bits

NL4	NL3	NL2	NL1	NL0	Display Size	Liquid crystal drive raster-rows	Gate driver lines Used
0	0	0	0	0	Setting disabled	Setting disabled	Setting disabled
0	0	0	0	1	528 x 16 dots	16	G1–G16
0	0	0	1	0	528 x 24 dots	24	G1–G24
0	0	0	1	1	528 x 32 dots	32	G1–G32
0	0	1	0	0	528 x 40 dots	40	G1–G40
0	0	1	0	1	528 x 48 dots	48	G1–G48
0	0	1	1	0	528 x 56 dots	56	G1–G56
0	0	1	1	1	528 x 64 dots	64	G1–G64
0	1	0	0	0	528 x 72 dots	72	G1–G72
		.			.	.	.
		.			.	.	.
		.			.	.	.
		.			.	.	.
		.			.	.	.
1	1	0	0	0	528 x 200 dots	200	G1–G200
1	1	0	0	1	528 x 208 dots	208	G1–G208
1	1	0	1	0	528 x 216 dots	216	G1–G216
1	1	0	1	1	528 x 224 dots	224	G1–G224
1	1	1	0	0	528 x 232 dots	232	G1–G232
1	1	1	0	1	528 x 240 dots	240	G1–G240

Note 1) A front porch period (set in the FP register) and a back porch period (set in the BP register) will be inserted as a blank period before and after driving all gate lines

LCD Driving Wave Form Control (R02h)

R/W	RS	IB15	IB14	IB13	IB12	IB11	IB10	IB9	IB8	IB7	IB6	IB5	IB4	IB3	IB2	IB1	IB0
W	1	0	0	0	0	FLD1	FLD0	B/C	EOR	0	0	NW5	NW4	NW3	NW2	NW1	NW0

**FLD1-0:** Specify the number of fields during n-field interlaced drive. For details, see the “interlaced drive” section.

This function is not available when an external display interface is selected. In the external display interface mode, make sure FLD1-0= “01”



**FLD1-0**

FLD1	FLD0	Number of Fields
0	0	Setting disabled
0	1	1 field
1	0	Setting disabled
1	1	3 fields

**NW5-0:** Specify n, the number of raster-rows from 1 to 64 to alternate every n+1 raster-rows when C-pattern waveform is generated (B/C = 1).

**EOR:** When EOR = 1 and a C-pattern waveform is generated (B/C =1), an odd/even frame select signal and an n-raster-row inversion signal are AC-driven. This instruction is available when liquid crystal AC drive is not made depending on the combination of numbers of LCD drive raster-rows and the value of “n” of n-raster-row inversion AC drive. For details, see “n-raster-row inversion AC drive”.

**B/C:** When B/C =0, a field AC waveform is generated. Alternation occurs every frame when driving liquid crystal. When B/C=1, alternation occurs every n raster-row. For details, see the “n-raster-row Inversion AC Drive” section.

**Entry Mode (R03h)**

**Compare Register 1 (R04h)**

**Compare Register 2 (R05h)**

R/W	RS	IB15	IB14	IB13	IB12	IB11	IB10	IB9	IB8	IB7	IB6	IB5	IB4	IB3	IB2	IB1	IB0
W	1	TRI	DFM1	DFM0	BGR	0	0	HWM	0	0	0	I/D1	I/D0	AM	LG2	LG1	LG0
W	1	0	0	CP11	CP10	CP9	CP8	CP7	CP6	0	0	CP5	CP4	CP3	CP2	CP1	CP0
W	1	0	0	0	0	0	0	0	0	0	0	CP17	CP16	CP15	CP14	CP13	CP12

The HD66789 modifies write data sent from the microcomputer before writing to GRAM. This enables high-speed GRAM data update, and reduces the load on the microcomputer software. For details, see the “Graphics Operation Function” section.

**TRI:** RAM write data are transmitted in 3 times through 8-bit interface when TRI = 1. When 8-bit interface mode is not selected, set TRI to 0.

**DFM1-0:** Specify the data format for the RAM write data transmission when TRI = 1 (8-bit interface mode only).

- DFM1-0 = “10”: 262k mode (6bit x 3 transmissions)
- DFM1-0 = “11”: 65k mode (5,6,5 bits transmissions)

**HWM:** When HWM=1, data are written to GRAM in high speed. In high-speed write mode, 4 words are written to GRAM in a single operation after executing 4 RAM write operations. If RAM write is terminated before it is executed 4 times, the last data will not be written. Make sure that RAM write is executed 4 times. For this reason, the lower 2 bits must be set to “0” when setting the RAM address. For details, see “High-Speed RAM Write Mode” section.

**I/D1-0:** The address counter is automatically incremented by 1, after data are written to GRAM when I/D1-0 = “1”. The address counter is automatically decremented by 1, after data are written to GRAM when I/D1-0 = “0”. An independent setting for the increment or decrement of the address counter can be made to the upper (AD15-8) and the lower (AD7-0) bits of the address. The address transition direction when data are written to GRAM is set with AM bits.

**AM:** Set the direction of updating address counter automatically after data are written to GRAM. When AM = “0”, the address counter is updated in the horizontal direction. When AM = “1”, the address counter is updated in the vertical direction. When the window address is specified, data are written to the GRAM area specified by the window address in the manner specified with I/D1-0, AM bits.

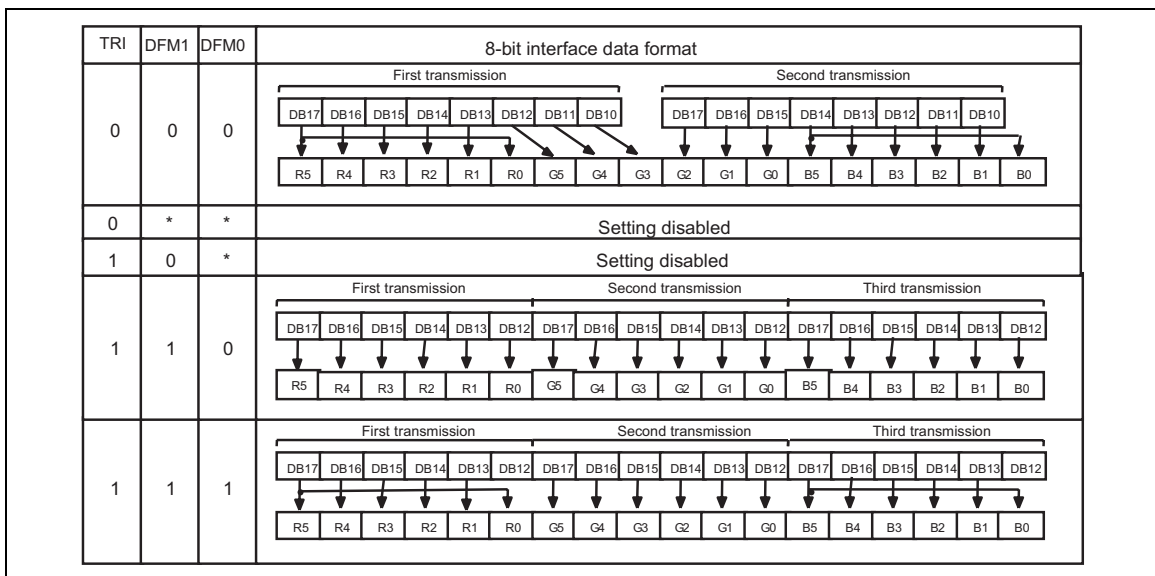

8-bit interface data format

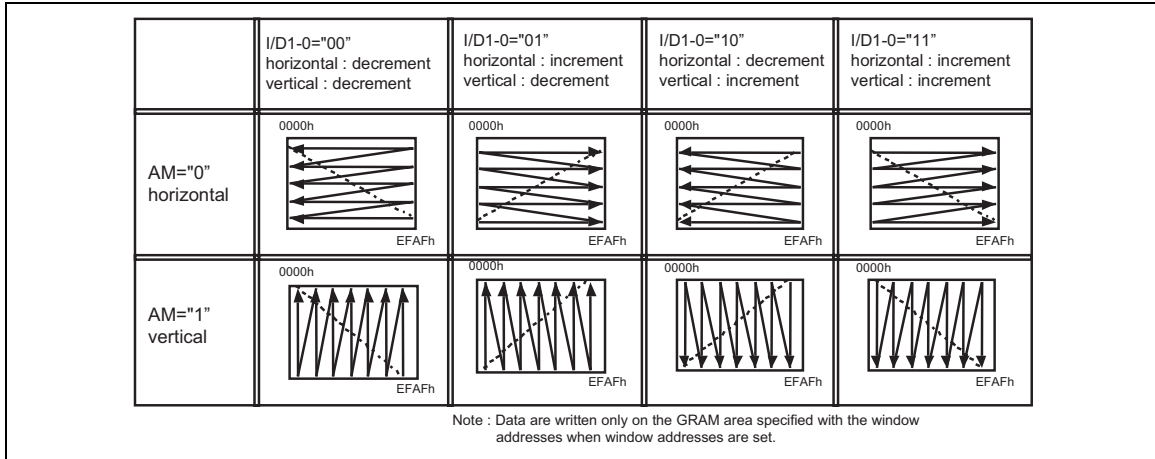

**Address transition direction**

**LG2-0:** Rewrite data to GRAM after comparing the data that are written by the microcomputer to GRAM with the values in the compare registers (CP17-0) and performing logical operation. For details, see the “Graphics Operation function”

**CP17-0:** Set the value for the compare register, with which the data read out from GRAM or data written to GRAM by the microcomputer are compared. This function is not available with the external display interface mode. In the external display interface mode, make sure LG2-0 = “000”.

**BGR:** Reverse the order from R, G, B to B, G, R to the 18-bit data to write to GRAM. When setting BGR = 1, CP17-0 and WM17-0 bits will be automatically changed to the same effect.

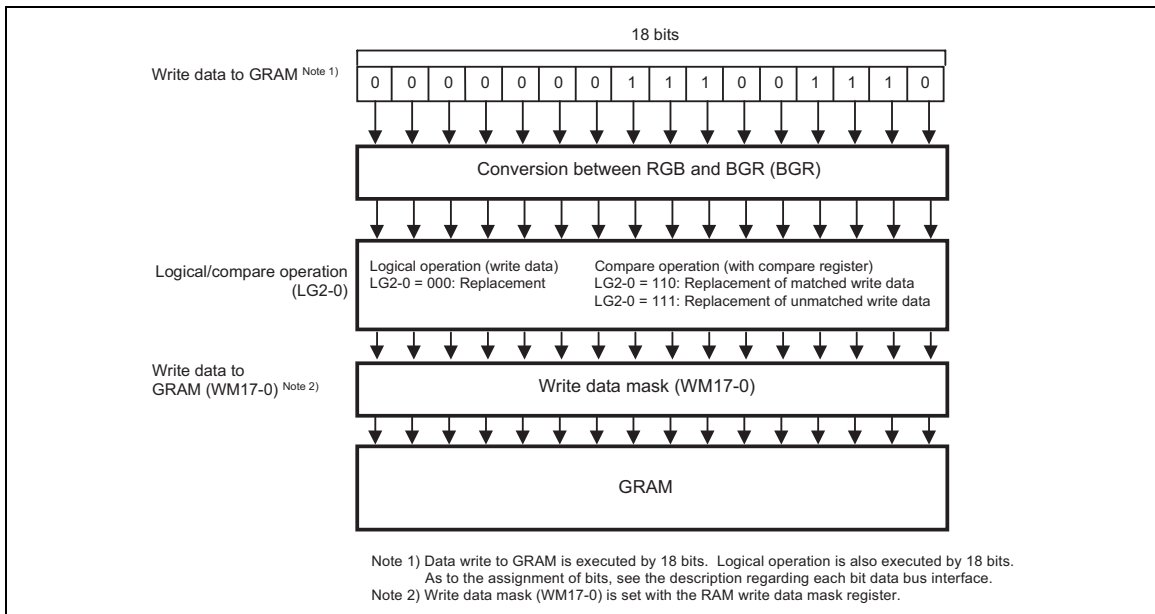

**Logic/Compare Operation**

**Display Control 1 (R07h)**

R/W	RS	IB15	IB14	IB13	IB12	IB11	IB10	IB9	IB8	IB7	IB6	IB5	IB4	IB3	IB2	IB1	IB0
W	1	0	0	0	PT1	PT0	VLE2	VLE1	SPT	0	0	GON	DTE	CL	REV	D1	D0

**PT1-0:** Determine the kind of source output in a non-display area in the partial display mode. For details, see the “Screen-split drive function” section.

**PT1-0 bits**

PT1	PT0	Source Output for Non-display Area	
		Positive Polarity	Negative Polarity
0	0	V31	V0
0	1	V31	V0
1	0	GND	GND
1	1	High impedance	High impedance

**VLE2-1:** When VLE1 = 1, the first screen is scrolled in the vertical direction. When VLE2 = 1, the second screen is scrolled in the vertical direction. The first and second screens cannot be scrolled simultaneously. This function is not available with the external display interface mode. In this case, make sure VLE2-1 = 0.

**VLE Bits**

VLE2	VLE1	Image on 2nd Screen	Image on 1st Screen
0	0	Stationary	Stationary
0	1	Stationary	Scrolled
1	0	Scrolled	Stationary
1	1	Setting disabled	Setting disabled

**CL:** When CL = 1, 8-color display mode is selected. For details, see the “8-Color Display Mode” section.

**CL Bit**

CL	Colors
0	262,144
1	8

**SPT:** When SPT = 1, liquid crystal is driven with 2 split screens. For details, see the “Screen Split Drive Function” section. This function is not available in the external display interface mode. In this case, make sure SPT = 0.

**REV:** When REV = 1, a reverse display is shown. Inverting the grayscale levels allows the display of same data on both normally white and normally black panels. The source output during front, back porch periods and blank periods during the 2-split-screen display is made in accordance with settings with PT1-0 bits.

#### Source Output in the Display Area

REV	GRAM Data	Source Output in the Display Area*	
		Positive Polarity	Negative Polarity
0	18'h00000	V31	V0
	18'h3FFFF	V0	V31
1	18'h00000	V0	V31
	18'h3FFFF	V31	V0

Note: The output on the source lines during the front and back porch periods and blanking of the partial display is determined with PT1-0 bits.

**GON:** When GON = 0, the gate-off level is GND.

**DTE:** When DTE = 0, the DISPTMG output is fixed to GND.

GON Bit		DTE Bit	
GON	Gate Output	DTE	DISPTMG Output
0	VGH/GND	0	Halt (GND)
1	VGH/VGL	1	Operation (Vcc/GND)

**D1-0:** The graphics display is on when D1 = 1, and off when D1 = 0. When setting D1 = 0, the data are retained in GRAM. This means the graphics is instantly redisplayed when setting D1 to 1. When D1 is 0 (i.e., the display is off) all the source outputs are set to the GND level. This reduces the charged/discharged current on LCD, accompanied by the liquid crystal AC drive.

When D1-0 = 01, the HD66789 continues the internal display operation, even while the external display is off. When D1-0 = 00, both the internal display operations and the external display operation are halted.

In combination with GON and DTE bits, D1-0 bits control ON/OFF of display. For details, see the "Instruction Setting Flow" section.

**D1-0**

D1	D0	Source Output	HD67789 Internal Operations	Gate-Driver Control Signals (CL1, FLM, and M)
0	0	GND	Halt	Halt
0	1	GND	Operate	Operate
1	0	Unlit display	Operate	Operate
1	1	Display	Operate	Operate

Note 1) Data are written to GRAM from the microcomputer irrespective of the setting of D1-0 bits.

Note 2) In the standby mode, D1-0 = "00". However, the D1-0 register setting before entering standby modes is retained.

**Display Control 2 (R08h)**

R/W	RS	IB15	IB14	IB13	IB12	IB11	IB10	IB9	IB8	IB7	IB6	IB5	IB4	IB3	IB2	IB1	IB0
W	1	0	0	0	0	FP3	FP2	FP1	FP0	0	0	0	0	BP3	BP2	BP1	BP0

**FP3-0/BP3-0:** Make settings for blank periods (the front and back porches), which are placed at the beginning and end of the display. FP3-0 and BP3-0 bits specify the number of raster-rows for the front and back porch respectively. When making this setting, make sure:

$$BP + FP = <16 \text{ raster-rows}$$

$$FP \geq 2 \text{ raster-rows}$$

$$BP \geq 2 \text{ raster-rows}$$

In the external display interface mode, the back porch (BP) starts on the falling edge of VSYNC signal, followed by display operation. After displaying the number of raster-rows set with NL bits, the front porch starts. After the front porch, a blank period ensues until an input of next VSYNC signal.

**FP and BP**

FP3	FP2	FP1	FP0	Number of lines for the Front Porch
BP3	BP2	BP1	BP0	Number of lines for the Back Porch
0	0	0	0	Setting disabled
0	0	0	1	Setting disabled
0	0	1	0	2
0	0	1	1	3
0	1	0	0	4
.	.	.	.	.
1	1	0	0	12
1	1	0	1	13
1	1	1	0	14
1	1	1	1	Setting disabled

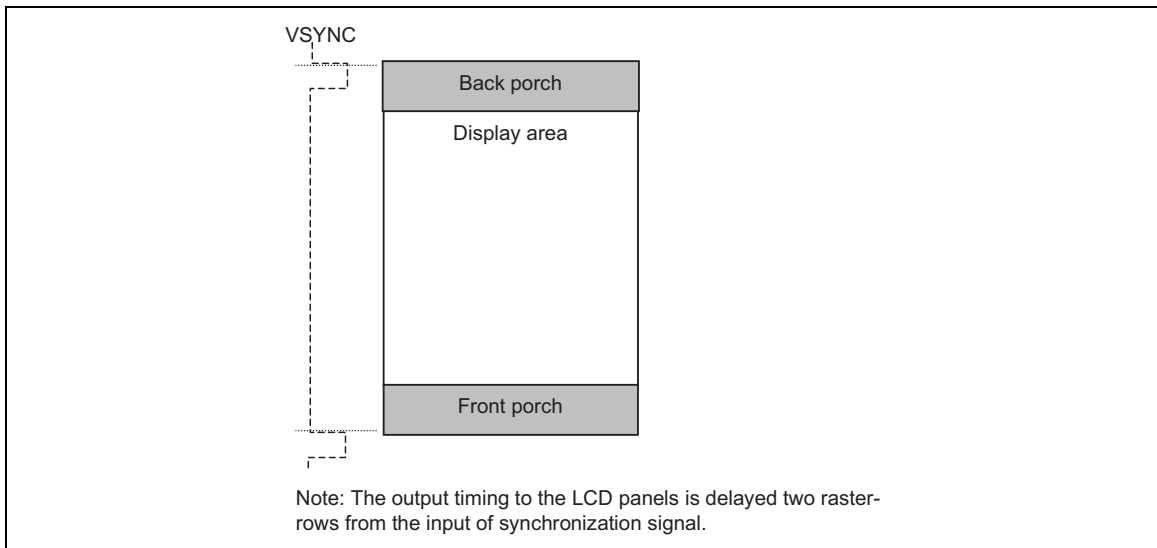

**External display interface**

**BP3-0, FP3-0 Setting**

Set BP3-0, FP3-0 bits as follows each in the following operation modes.

<b>Operation of internal clock</b>	<b>FLD1-0 = 01</b>	BP >= 2 lines	FP >= 2 lines	FP +BP <= 16 lines
	<b>FLD1-0 = 11</b>	BP = 3 lines	FP = 5 lines	
<b>RGB interface</b>		BP >= 2 lines	FP >= 2 lines	FP +BP <= 16 lines
<b>VSYNC interface</b>		BP >= 2 lines	FP >= 2 lines	FP +BP = 16 lines

**Display control 3 (R09h)**

R/W	RS	IB15	IB14	IB13	IB12	IB11	IB10	IB9	IB8	IB7	IB6	IB5	IB4	IB3	IB2	IB1	IB0
W	1	0	0	0	0	0	0	0	0	0	0	PTG1	PTG0	ISC3	ISC2	ISC1	ISC0

**PTG1-0:** Set the gate scan mode when non-display area is driven.

PTG1	PTG0	Gate output in non-display area	Source output in non-display area	Vcom output
0	0	normal scan	PT setting	VcomH/VcomL amplitude
0	1	VGL (fixed)	PT setting	VcomH/VcomL amplitude
1	0	interval scan	PT setting	VcomH/VcomL amplitude
1	1	setting disabled	–	–



**ISC 3-0:** Set the frequency of gate scan when the gate scan mode in the non-display area is set to the interval scan mode with PTG bits. The scan frequency always occurs per odd frames, which is set with ISC bits, and inverted polarity is applied as the gate line is scanned.

**Gate scan frequency**

ISC3	ISC2	ISC1	ISC0	Scan frequency	(f FLM) = 60Hz
0	0	0	0	0 frame	–
0	0	0	1	3 frames	50 mS
0	0	1	0	5frames	84 mS
0	0	1	1	7 frames	117 mS
0	1	0	0	9 frames	150 mS
0	1	0	1	11 frames	184 mS
0	1	1	0	13 frames	217 mS
0	1	1	1	15 frames	251 mS
1	0	0	0	17 frames	284 mS
1	0	0	1	19 frames	317 mS
1	0	1	0	21 frames	351 mS
1	0	1	1	23 frames	384 mS
1	1	0	0	25 frames	418 mS
1	1	0	1	27 frame	451 mS
1	1	1	0	29 frame	484 mS
1	1	1	1	31 frame	518 mS

**Frame Cycle Control (R0Bh)**

R/W	RS	IB15	IB14	IB13	IB12	IB11	IB10	IB9	IB8	IB7	IB6	IB5	IB4	IB3	IB2	IB1	IB0
W	1	NO1	NO0	SDT1	SDT0	EQ1	EQ0	DIV1	DIV0	0	0	0	0	RTN3	RTN2	RTN1	RTN0

**RTN3-0:** Set the 1H (1 raster-row) period.

RTN3	RTN2	RTN1	RTN0	Clock Cycles per Raster-row
0	0	0	0	16 clocks
0	0	0	1	17 clocks
0	0	1	0	18 clocks
		:	:	
1	1	1	0	30 clocks
1	1	1	1	31 clocks

**DIV1-0:** Set the division ratio of clocks for internal operations (DIV1-0). Internal operations are in synchronization with the clock, the frequency of which is divided according to the DIV1-0 setting. Frame frequency can be adjusted in combination with the adjustment of 1H period (RTN 3-0). When changing the number of drive raster-rows, adjust the frame frequency too. For details, see “Frame Frequency Adjustment Function”. When the RGB interface is selected, this function is not available.

**DIV Bits and Division Ratio**

DIV1	DIV0	Division Ratio	Internal Operating Clock Frequency
0	0	1	fosc / 1
0	1	2	fosc / 2
1	0	4	fosc / 4
1	1	8	fosc / 8

fosc = R-C oscillation frequency

**Formula for the frame frequency**

$$\text{Frame frequency} = \frac{\text{fosc}}{\text{Clock cycles per raster-row} \times \text{division ratio} \times (\text{Line} + \text{BP} + \text{FP})} \quad [\text{Hz}]$$

fosc: R-C oscillation frequency  
 Line: number of drive raster-rows (NL bit)  
 Division ratio: DIV bit  
 Clock cycles per raster-row: RTN bit  
 FP : the number of raster-rows in the front porch  
 BP : the number of raster-rows in the back porch

**EQ1-0:** Equalizing period is prolonged as the number of clocks specified with EQ1-0 bits. The equalization signal is output only with the alternating current.

**EQ Bits**

EQ1	EQ0	Equalizing period	
		Internal Operation (synchronized with the internal operating clock)	RGB I/F Operation (synchronized with DOTCLK)
0	0	Not equalized	Not equalized
0	1	1 clock	8 clocks
1	0	2 clocks	16 clocks
1	1	3 clocks	24 clocks

**SDT1-0:** Determine the amount of delay for the source output from the falling edge of the gate output.

**SDT Bits**

**Delay Time for Source Signal**

SDT1	SDT0	Internal Operation (synchronized with the internal operating clock)	RGB I/F Operation (synchronized with DOTCLK)
0	0	1 clock	8 clocks
0	1	2 clocks	16 clocks
1	0	3 clocks	24 clocks
1	1	4 clocks	32 clocks

Note 1) The amount of delay for the source output is measured from the falling edge of the CL1.

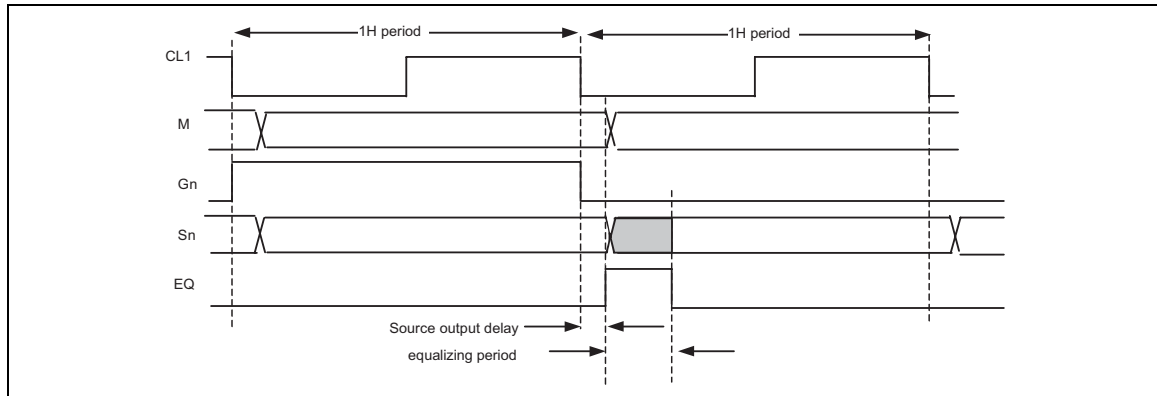

**Source output delay and equalize period**

Note 1) In internal operation and VSYNC interface modes, the reference clock is the internal operating clock. In RGB interface modes, the reference clock is DOTCLK.

**NO1-0:** Specify the amount of non-overlap time for the gate output.

In the internal operation and VSYNC interface modes, the reference clock is the internal operating clock. In the RGB interface mode, the reference clock is DOTCLK.

**NO Bits**

**Non-overlap time**

NO1	NO0	Internal Operation (synchronized with the internal operating clock)	RGB I/F Operation (synchronized with DOTCLK)
0	0	0 clock	0 clock
0	1	4 clocks	32 clocks
1	0	6 clocks	48 clocks
1	1	8 clocks	64 clocks

Note 1) The amount of non-overlap time is defined from the falling edge of the CL1.

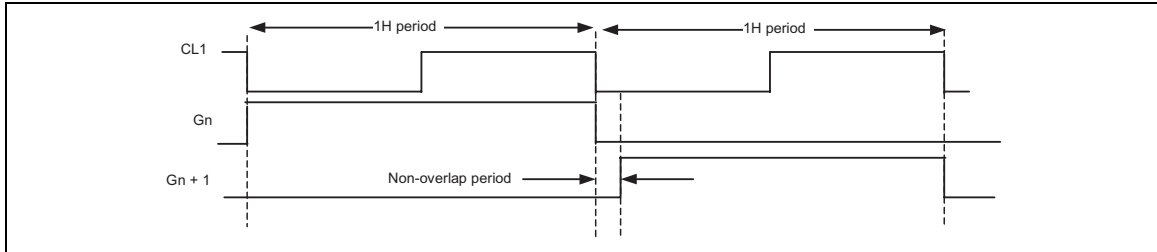

Non-overlap period

External Display Interface Control (R0Ch)

R/W	RS	IB15	IB14	IB13	IB12	IB11	IB10	IB9	IB8	IB7	IB6	IB5	IB4	IB3	IB2	IB1	IB0
W	1	0	0	0	0	0	0	0	RM	0	0	DM1	DM0	0	0	RIM1	RIM0

**RIM1-0:** Specify the RGB I/F mode when the RGB interface is selected. Specifically, this setting specifies the RGB interface mode when it is selected by setting DM and RM bits. The setting must be made before the display operation through the external display interface. Do not make a setting during display.

RIM Bits

RIM1	RIM0	RGB Interface Mode
0	0	18-bit RGB interface (one-time transfer/pixel)
0	1	16-bit RGB interface (one-time transfer/pixel)
1	0	6-bit RGB interface (three-time transfers/pixel)
1	1	Setting disabled

Note 1) The instruction register setting is possible only through a system interface.

Note 2) Data transmission and input of DOTCLK in the 6-bit RGB interface mode should be executed by RGB.

**DM1–0:** Specify the display operation mode. The interface through which display operation is executed is selected with DM1-0 bits. This setting enables switching between internal clock operation and external display interface. Switching within the external display interface modes (between RGB-I/F and VSYNC-I/F) cannot be made.

#### DM Bits

DM1	DM0	Display Interface
0	0	Internal clock operation
0	1	RGB interface
1	0	VSYNC interface
1	1	Setting disabled

**RM:** Specify the interface for RAM accesses. RAM is accessible only through the interface specified with RM bit. When the display data is written through RGB-I/F, set RM = 1. The RM-bit setting can be made irrespective of the display operation mode. This means the display data can be updated through a system interface even during the display period through RGB interface by setting RM = 0.

#### RM Bit

RM	Interface for RAM Access
0	System interface/VSYNC interface
1	RGB interface

Setting for external display interface control allows selecting an optimum interface for the kind of display as follows. When displaying a moving picture (RGB-I/F/VSYNC-I/F), the display data must be written in the high-speed mode (HWM = 1) which enables high-speed RAM access with low power consumption.

#### Display state and interfaces

Display State	Operation Mode	RAM Access (RM)	Display Operation Mode (DM1-0)
Still pictures	Internal clock operation	System interface (RM = 0)	Internal clock operation (DM1-0 = 00)
Moving pictures	RGB interface (1)	RGB interface (RM = 1)	RGB interface (DM1-0 = 01)
Rewrite still picture area while displaying moving pictures.	RGB interface (2)	System interface (RM = 0)	RGB interface (DM1-0 = 01)
Moving pictures	VSYNC interface	System interface (RM = 0)	VSYNC interface (DM1-0 = 10)

Note 1) The instruction register setting is made only through a system interface.

Note 2) Switching between RGB-I/F and VSYNC-I/F cannot be made.

Note 3) The RGB-I/F mode settings is not changeable during RGB I/F operation.

Note 4) For details on the transition flow between operation modes, see the "External Display Interface" section.

Note 5) Use the high-speed write mode (HWM = 1) during the write operation in RGB-I/F and VSYNC-I/F modes.

#### Internal clock operation mode

All display operations are controlled by signals generated by the internal clock in internal clock operation mode. All inputs through the external display interface are invalid. The internal RAM is accessible only through a system interface.

#### RGB interface mode (1)

Display operation is controlled by the frame synchronization clock (VSYNC), line synchronizing signal (VSYNCR), and dot clock (DOTCLK) in the RGB interface mode. These signals must be supplied throughout the display operation in this mode.

All display data are stored in the internal RAM, transmitted with PD17-0 bits by pixel. The combination with the high-speed write mode and window address function enables simultaneous display of both moving picture areas and the internal RAM area. The data are transmitted only when the screen is being updated, thereby reducing the overall data transmission to minimum.

The periods of the front (FP) and back (BP) porches and the display period (NL) are automatically generated in the HD66782 by counting the clock of line synchronizing signal (HSYNC) in accordance to the frame synchronizing signal (VSYNCR). Transmit pixel data with PD 17-0 bits in accordance with the setting specified above.

**RGB interface mode (2)**

When RGB-I/F is selected, RAM data are changeable through the system interface. This write operation must be performed while display data are not being transmitted through the RGB-I/F (ENABLE = High). When reverting from the system interface mode to the data transmission through the RGB interface, make a new setting for the address set and index (R22h) after changing the aforementioned settings.

**VSYNC interface mode**

The internal display operation is synchronized with the frame-synchronizing signal (VSYNC) in the VSYNC interface mode. By writing data to RAM at a fixed speed on the falling edge of VSYNC, it enables moving pictures display with a system interface. In this case, there are some constraints in the RAM write speed and methods. For details, see the “External Display Interface” section.

In the VSYNC-I/F mode, only VSYNC input is valid. Other input signals for the external display interface are invalid.

The front porch (FP), back porch (BP) periods and display period (NL) are automatically generated in accordance to the frame synchronizing signal (VSYNC) according to the register setting of HD66789.

**Power Control 1 (R10h)**

**Power Control 2 (R11h)**

R/W	RS	IB15	IB14	IB13	IB12	IB11	IB10	IB9	IB8	IB7	IB6	IB5	IB4	IB3	IB2	IB1	IB0
W	1	0	SAP2	SAP1	SAP0	0	BT2	BT1	BT0	0	AP2	AP1	AP0	0	DK	SLP	STB
W	1	0	0	0	0	0	DC12	DC11	DC10	0	DC02	DC01	DC00	0	VC2	VC1	VC0

**SAP2-0:** Adjust the amount of fixed current from the fixed current source of operational amplifier for the source driver. When the amount of fixed current is set large, the operational amplifier will stabilize, while the current consumption will increase. Select an optimum amount of current taking both the display quality and the current consumption into account. During non-display operation, set SAP2-0 = “000” to halt the operation of operational amplifier, to reduce the current consumption.

**SAP Bits and the amount of current for the Op-amp**

SAP2	SAP1	SAP0	Op-amp Current	SAP2	SAP1	SAP0	Op-amp Current
0	0	0	Halt	1	0	0	1 (fixed)
0	0	1	Setting disabled	1	0	1	1.25 (fixed)
0	1	0	0.62 (fixed)	1	1	0	1.43 (fixed)
0	1	1	0.71 (fixed)	1	1	1	Setting disabled

**BT2-0:** Change the step-up scale of the step-up circuit. Adjust the scale according to the voltage. Smaller scale consumes lesser current.

**DC02-00:** Select the operating frequency for the step-up circuit 1. The higher frequency enhances the drive capacity of step-up circuit as well as the display quality, while the current consumption will increase. Adjust the frequency taking both the display quality and the current consumption into consideration.

**DC12-10:** Select the operating frequency for the step-up circuit 2. The higher frequency enhances the drive capacity of step-up circuit as well as the display quality, while the current consumption will increase. Adjust the frequency taking both the display quality and the current consumption into consideration.

**AP2-0:** Adjust the amount of fixed current from the fixed current source of operational amplifier for the liquid crystal drive power supply. When the amount of fixed current is set large, the liquid crystal drive capacity will be enhanced and the display quality will improve, while the current consumption will increase. Select an optimum amount of current taking both the display quality and the current consumption into account. During non-display operation, set AP2-0 = “000” to halt the operation of operational amplifier to reduce current consumption.

**DK:** Control the operation of the step-up circuit 1. When turning on the power supply, stop the start up of VLOUT1 for a moment, and wait for an enough time until VLOUT2 is stabilized before starting up VLOUT1. For details, see the “Power Supply Setting Flow” section.



**SLP:** When SLP = 1, the HD66789 enters into the sleep mode. In the sleep mode, internal display operation is halted except the R-C oscillator to reduce current consumption. Only power control instructions (BT2-0, DC2-0, AP2-0, SLP, STB, VC2-0, VRH4-0, VCOMG, VDV4-0, and VCM4-0 bits) are executed during the sleep mode. No change is made to the GRAM data or instructions during the sleep mode, although it is retained.

**STB:** When STB = 1, the HD66789 enters into the standby mode. In the standby mode, display operation is completely halted, and all internal operation including the internal R-C oscillator and reception of external clock pulse, is halted. For details, see the “Standby Mode” section. Only instructions to release the standby mode (STB = 0) and to start oscillation are accepted during the standby mode. Changes in the GRAM data or instructions during the standby mode are susceptible to destruction. These changes should be made after releasing the standby mode.

**VC2-0:** Adjust the reference voltage for VLEG1OUT, VciOUT voltages to the optimum ratio of Vci.

AP2	AP1	AP0	Amount of current in operational amplifier
0	0	0	halt
0	0	1	setting disabled
0	1	0	0.5 (fixed)
0	1	1	0.75 (fixed)
1	0	0	1 (fixed)
1	0	1	1.25 (fixed)
1	1	0	1.5 (fixed)
1	1	1	setting disabled

DC02	DC01	DC00	Step-up circuit 1 step-up frequency
0	0	0	oscillation clock/8
0	0	1	oscillation clock/16
0	1	0	oscillation clock/32
0	1	1	oscillation clock/64
1	0	0	oscillation clock/128
1	0	1	setting disabled
1	1	0	setting disabled
1	1	1	setting disabled

DC12	DC11	DC10	Step-up circuit 2 step-up frequency
0	0	0	oscillation clock/16
0	0	1	oscillation clock/32
0	1	0	oscillation clock/64
0	1	1	oscillation clock/128
1	0	0	oscillation clock/256
1	0	1	setting disabled
1	1	0	setting disabled
1	1	1	setting disabled

BT2	BT1	BT0	VLOUT1 output (DDVDH)	VLOUT4 output (VCL)	VLOUT2 output (VGH)	VLOUT3 output (VGL)	Capacitor connection pins
0	0	0	$V_{ci1} \times 2$ [x2]	$V_{ci1} \times -1$ [x-1]	DDVDH x 3 [x 6]	$-(V_{ci1} + DDVDH) \times 2$ [x -5]	DDVDH, VGH, VGL, VCL, C11±, C12±, C21±, C22±,
0	0	1			DDVDH x 3 [x 6]	$-(DDVDH) \times 2$ [x -4]	DDVDH, VGH, VGL, VCL, C11±, C12±, C21±, C22±,
0	1	0			DDVDH x 3 [x 6]	$-(V_{ci1} + DDVDH)$ [x -3]	DDVDH, VGH, VGL, VCL, C11±, C12±, C21±, C22±,
0	1	1			$V_{ci1} + DDVDH \times 2$ [x 5]	$-(V_{ci1} + DDVDH) \times 2$ [x -5]	DDVDH, VGH, VGL, VCL, C11±, C12±, C21±, C22±,
1	0	0			$V_{ci1} + DDVDH \times 2$ [x 5]	$-(DDVDH) \times 2$ [x -4]	DDVDH, VGH, VGL, VCL, C11±, C12±, C21±, C22±,
1	0	1			$V_{ci1} + DDVDH \times 2$ [x 5]	$-(V_{ci1} + DDVDH)$ [x -3]	DDVDH, VGH, VGL, VCL, C11±, C12±, C21±, C22±,
1	1	0			DDVDH x 2 [x 4]	$-(DDVDH) \times 2$ [x -4]	DDVDH, VGH, VGL, VCL, C11±, C12±, C21±, C22±,
1	1	1			DDVDH x 2 [x 4]	$-(V_{ci1} + DDVDH)$ [x -3]	DDVDH, VGH, VGL, VCL, C11±, C12±, C21±

Note 1) The numerals in the bracket [ ] show the step-up scale from  $V_{ci1}$ .

Note 2) The capacitor connection pins are step-up capacitors which are necessary for DDVDH, VCL, VGH, VGL voltages.

Note 3) Set the voltage within the following range: DDVDH = 5.5 V (Max.), VCL = - 3.3 V (Min.), VGH = 16.5 V (Max.), VGL = -16.5 V (Min.)

VC2	VC1	VC0	Step-up circuit 1 step-up frequency	DK	Operation of step-up circuit 1
0	0	0	$V_{ci}$	0	Operation
0	0	1	$0.92 \times V_{ci}$	1	Halt
0	1	0	$0.87 \times V_{ci}$		
0	1	1	$0.83 \times V_{ci}$		
1	0	0	$0.76 \times V_{ci}$		
1	0	1	$0.73 \times V_{ci}$		
1	1	0	setting disabled		
1	1	1	setting disabled		

**Power Control 3 (R12h)****Power Control 4 (R13h)**

R/W	RS	IB15	IB14	IB13	IB12	IB11	IB10	IB9	IB8	IB7	IB6	IB5	IB4	IB3	IB2	IB1	IB0
W	1	0	0	0	0	0	0	0	0	0	0	0	PON	VRH3	VRH2	VRH1	VRH0
W	1	0	0	VCOMG	VDV4	VDV3	VDV2	VDV1	VDV0	0	0	0	VCM4	VCM3	VCM2	VCM1	VCM0

**PON:** Start operation of VLOUT3. To stop operation, set PON = 0. To start operation, set PON = 1.

**VRH3-0:** Set the scale for amplifying VLOUT1 voltage (the reference voltage for VCOM and grayscale voltage). REGP voltage is amplified by 1.33 ~ 2.775 times.

**VCOMG:** When VCOMG = 1, VcomL outputs a negative voltage (1.0V ~ -Vci+0.5V Max.). When VCOMG = 0, the amplifiers for the negative voltage is halted, thereby saving power consumption. When VCOMG = 0, settings with VDV4-0 bits are invalid. In this case, to adjust AC amplitude of Vcom, make settings with VCM4-0 bits (VcomH setting). VCOMG = 1 is valid when PON = 1.

**VDV4-0:** Set the AC amplitude of Vcom during Vcom AC drive. The amplitude can be specified within the range of 0.6 ~ 1.23 times of VREG1OUT. When VCOMG = 0, this setting is invalid.

**VCM4-0:** Set the VcomH voltage (The higher voltage during Vcom AC drive). The voltage can be specified within the range of 0.4 ~ 0.98 times of VREG1OUT. When VCM4-0 = "11111", the internal volume adjustment operation is halted, and the VcomH voltage can be adjust by placing an external resistor from VcomR.

---

VRH3	VRH2	VRH1	VRH0	VREG1OUT voltage
0	0	0	0	REGP x 1.33
0	0	0	1	REGP x 1.45
0	0	1	0	REGP x 1.55
0	0	1	1	REGP x 1.65
0	1	0	0	REGP x 1.75
0	1	0	1	REGP x 1.80
0	1	1	0	REGP x 1.85
0	1	1	1	halt
1	0	0	0	REGP x 1.90
1	0	0	1	REGP x 2.175
1	0	1	0	REGP x 2.325
1	0	1	1	REGP x 2.475
1	1	0	0	REGP x 2.625
1	1	0	1	REGP x 2.700
1	1	1	0	REGP x 2.775
1	1	1	1	halt

---

VCM4	VCM3	VCM2	VCM1	VCM0	VcomH	VDV4	VDV3	VDV2	VDV1	VDV0	Vcom amplitude
0	0	0	0	0	VREG1OUT x 0.40	0	0	0	0	0	VREG1OUT x 0.60
0	0	0	0	1	VREG1OUT x 0.42	0	0	0	0	1	VREG1OUT x 0.63
0	0	0	1	0	VREG1OUT x 0.44	0	0	0	1	0	VREG1OUT x 0.66
:	:	:	:	:	:	:	:	:	:	:	:
0	1	1	0	0	VREG1OUT x 0.64	0	1	1	0	0	VREG1OUT x 0.96
0	1	1	0	1	VREG1OUT x 0.66	0	1	1	0	1	VREG1OUT x 0.99
0	1	1	1	0	VREG1OUT x 0.68	0	1	1	1	0	VREG1OUT x 1.02
0	1	1	1	1	Halt internal volume. Adjust with a variable external resistor from VcomR.	0	1	1	1	1	Setting disabled
1	0	0	0	0	VREG1OUT x 0.70	1	0	0	0	0	VREG1OUT x 1.05
1	0	0	0	1	VREG1OUT x 0.72	1	0	0	0	1	VREG1OUT x 1.08
1	0	0	1	0	VREG1OUT x 0.74	1	0	0	1	0	VREG1OUT x 1.11
:	:	:	:	:	:	:	:	:	:	:	:
1	1	1	0	0	VREG1OUT x 0.94	1	0	1	0	0	VREG1OUT x 1.17
1	1	1	0	1	VREG1OUT x 0.96	1	0	1	0	1	VREG1OUT x 1.20
1	1	1	1	0	VREG1OUT x 0.98	1	0	1	1	0	VREG1OUT x 1.23
1	1	1	1	1	Halt internal volume. Adjust with a variable external resistor from VcomR.	1	0	1	1	1	Setting disabled
						1	1	*	*	*	Setting disabled

Note 1) Adjust VREG1OUT and VCM0-4 to set VcomH the same level as VDH or less.

Note 2) Adjust VREG1OUT and VDV0-4 to set the amplitude of Vcom 0.6V or less.

**RAM Address Set (R21h)**

R/W	RS	IB15	IB14	IB13	IB12	IB11	IB10	IB9	IB8	IB7	IB6	IB5	IB4	IB3	IB2	IB1	IB0
W	1	AD 15	AD 14	AD 13	AD 12	AD 11	AD 10	AD 9	AD 8	AD 7	AD 6	AD 5	AD 4	AD 3	AD 2	AD 1	AD 0

**AD15-0:** Make the initial setting of GRAM address in the address counter (AC). After GRAM data are written, the address counter is automatically updated according to the settings with AM, I/D bits and the setting for a new GRAM address is not required in the address counter. Therefore, data are written consecutively without resetting the address. The address counter is not automatically updated when data are read out from GRAM.

GRAM address setting can not be made during the standby mode. An address set should be made within the area specified with the window address.

When the RGB interface is selected (RM = 1), the setting of the address for AD15-0 is made every frame at the falling edge of VSYNC. When the internal clock operation or VSYNC interface is selected (RM = 0), the setting of the address is made when the instruction is executed.

**GRAM Address Range**

AD15-AD0	GRAM Setting
"0000"H – "00AF"H	Bitmap data for G1
"0100"H – "01AF"H	Bitmap data for G2
"0200"H – "02AF"H	Bitmap data for G3
"0300"H – "03AF"H	Bitmap data for G4
:	:
"EC00"H – "ECAAF"H	Bitmap data for G237
"ED00"H – "EDAF"H	Bitmap data for G238
"EE00"H – "EEAF"H	Bitmap data for G239
"EF00"H – "EFAF"H	Bitmap data for G240

**Write Data to GRAM (R22h)**

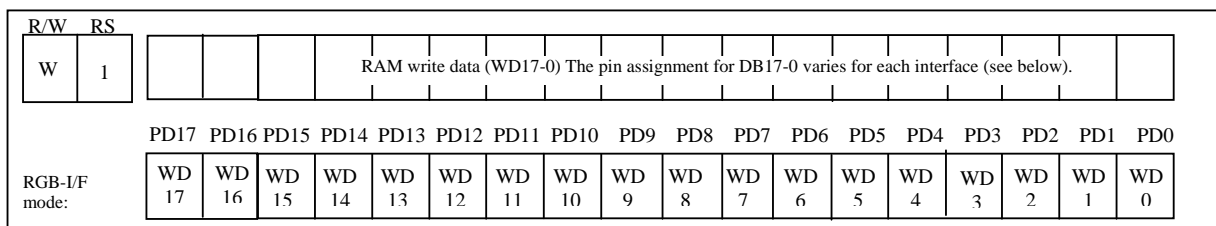

**WD17-0:** All data are expanded into 18 bits internally before written to GRAM. Each interface has its own way of expanding data to 18 bits.

The grayscale level is selected according to GRAM data. The address is automatically updated according to the setting with the AM and I/D bits after data are written to GRAM. During the standby mode, no access is allowed to GRAM. When 8 or 16 bit interface modes is selected, the data in the MSB of R and B pixels are also written to the LSB of R and B pixels respectively to expand the 8/16-bit data into the 18bit data internally.

During the RGB interface mode, when writing data to RAM through a system interface, make sure to avoid conflicts between writing through the RGB interface and writing through the system interface.

When the 18-bit RGB interface is selected, the 18-bit data in PD17-0 bits are written, and 262,144 colors are available. When the 16-bit RGB interface is selected, the data in the MSB of R and B pixels are also written to the LSB of R and B pixels respectively, and 65,536 colors are available.

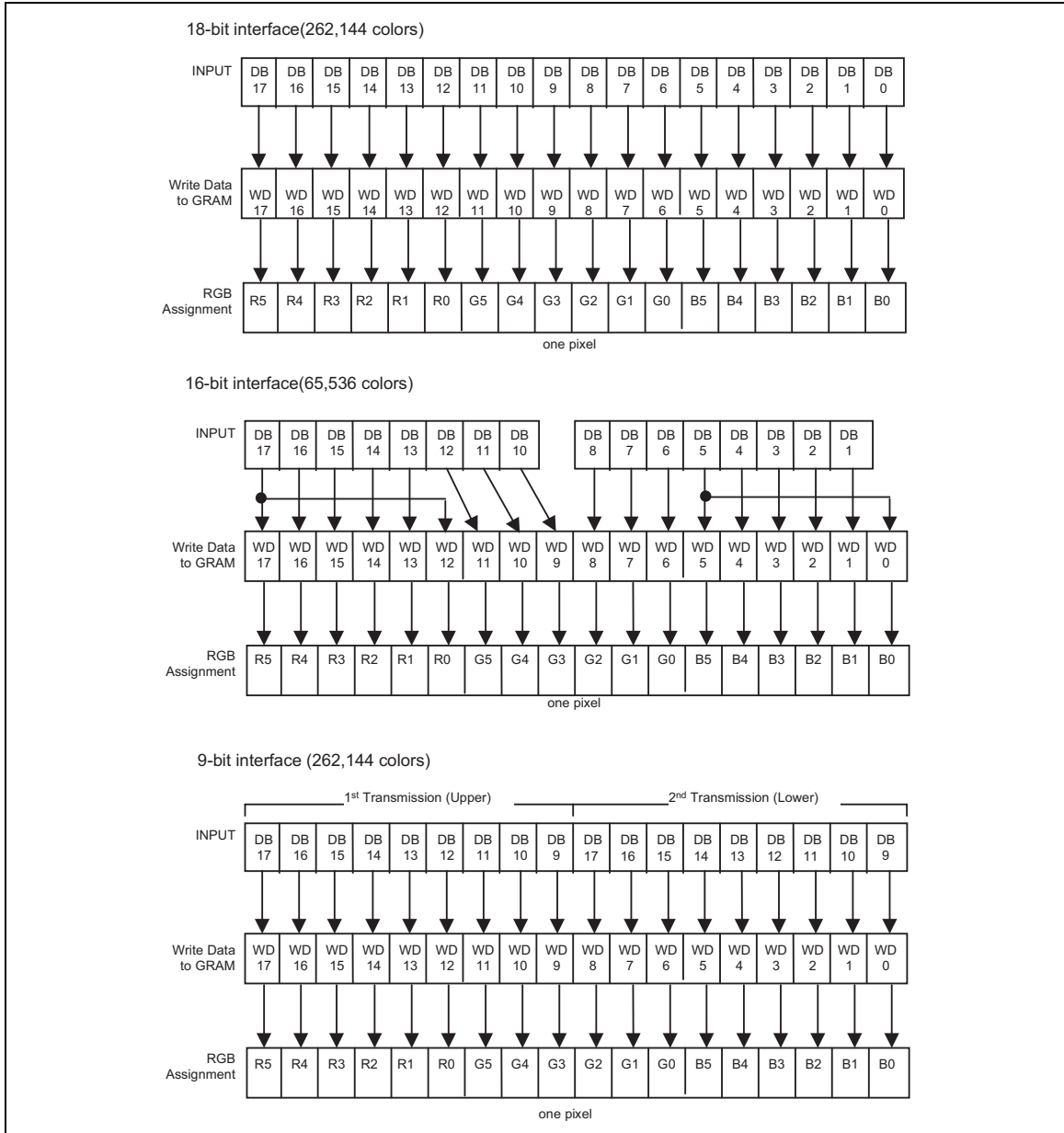

**Write data to GRAM: Bit assignment**

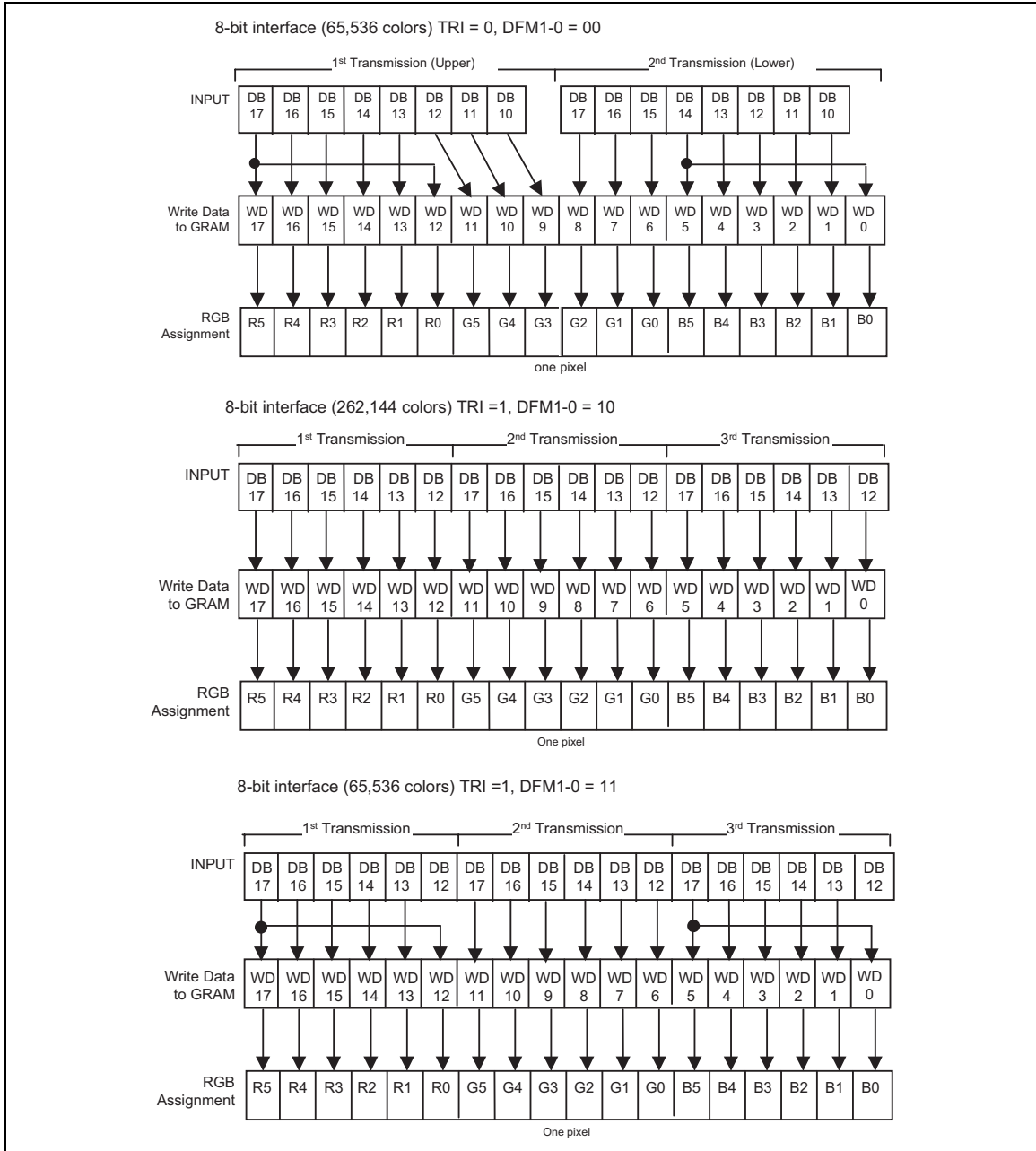

Write data to GRAM: Bit assignment



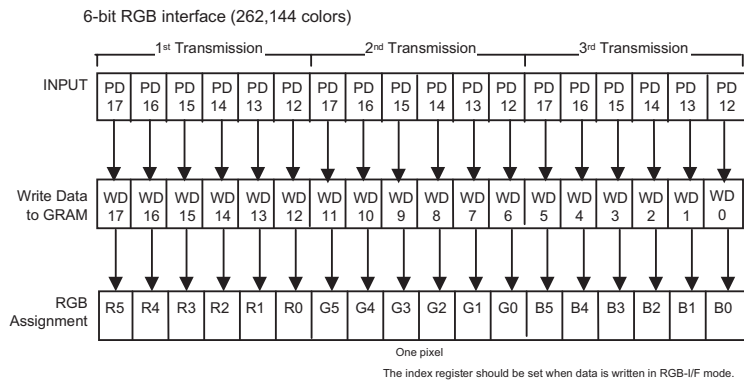
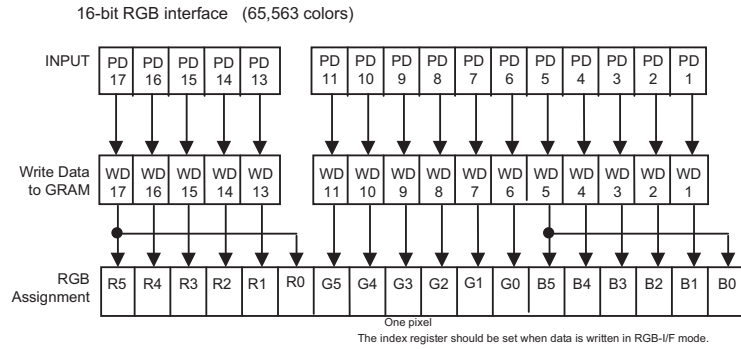
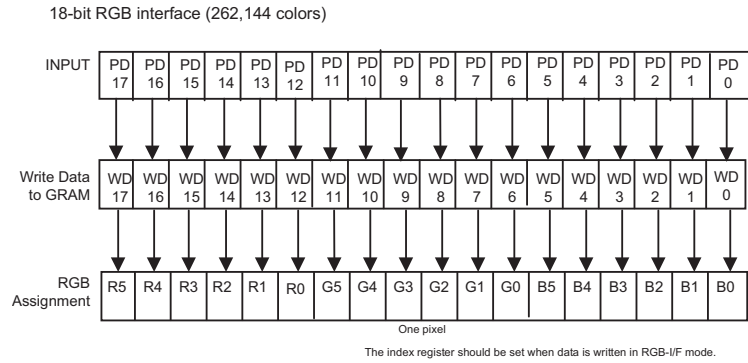

**Write data to GRAM (RGB interface): Bit assignment**

GRAM data settings RGB	Grayscale		GRAM data settings RGB	Grayscale	
	Negative	Positive		Negative	Positive
000000	V0	V31	100000	V16	V15
000001	$(V0-V1)/2$	$(V30-V31)/2$	100001	$(V16-V17)/2$	$(V14-V15)/2$
000010	V1	V30	100010	V17	V14
000011	$(V1-V2)/2$	$(V29-V30)/2$	100011	$(V17-V18)/2$	$(V13-V14)/2$
000100	V2	V29	100100	V18	V13
000101	$(V2-V3)/2$	$(V28-V29)/2$	100101	$(V18-V19)/2$	$(V12-V13)/2$
000110	V3	V28	100110	V19	V12
000111	$(V3-V4)/2$	$(V27-V28)/2$	100111	$(V19-V20)/2$	$(V11-V12)/2$
001000	V4	V27	101000	V20	V11
001001	$(V4-V5)/2$	$(V26-V27)/2$	101001	$(V20-V21)/2$	$(V10-V11)/2$
001010	V5	V26	101010	V21	V10
001011	$(V5-V6)/2$	$(V25-V26)/2$	101011	$(V21-V22)/2$	$(V9-V10)/2$
001100	V6	V25	101100	V22	V9
001101	$(V6-V7)/2$	$(V24-V25)/2$	101101	$(V22-V23)/2$	$(V8-V9)/2$
001110	V7	V24	101110	V23	V8
001111	$(V7-V8)/2$	$(V23-V24)/2$	101111	$(V23-V24)/2$	$(V7-V8)/2$
010000	V8	V23	110000	V24	V7
010001	$(V8-V9)/2$	$(V22-V23)/2$	110001	$(V24-V25)/2$	$(V6-V7)/2$
010010	V9	V22	110010	V25	V6
010011	$(V9-V10)/2$	$(V21-V22)/2$	110011	$(V25-V26)/2$	$(V5-V6)/2$
010100	V10	V21	110100	V26	V5
010101	$(V10-V11)/2$	$(V20-V21)/2$	110101	$(V26-V27)/2$	$(V4-V5)/2$
010110	V11	V20	110110	V27	V4
010111	$(V11-V12)/2$	$(V19-V20)/2$	110111	$(V27-V28)/2$	$(V3-V4)/2$
011000	V12	V19	111000	V28	V3
011001	$(V12-V13)/2$	$(V18-V19)/2$	111001	$(V28-V29)/2$	$(V2-V3)/2$
011010	V13	V18	111010	V29	V2
011011	$(V13-V14)/2$	$(V17-V18)/2$	111011	$(V29-V30)/2$	$(V1-V2)/2$
011100	V14	V17	111100	V30	V1
011101	$(V14-V15)/2$	$(V16-V17)/2$	111101	$(V30-V31)/2$	$(V0-V1)/2$
011110	V15	V16	111110	$(V30-V31)/3$	$(V0-V1)/3$
011111	$(V15-V16)/2$	$(V15-V16)/2$	111111	V31	V0

GRAM data and LCD output level

**RAM Access through RGB-I/F and System I/F**

The HD66789 writes all display data on the screens to the internal RAM. This enables the transfer of only the data for the moving picture area as well as for the frames for updating screens through the RGB interface. By writing data in the high speed write mode (HWM = 1) and with the window address function, the HD66789 enables a high-speed access to RAM with low power consumption while displaying moving pictures. In the frames other than the moving picture screen update, the display data in the area other than the moving picture area can be updated through a system interface.

The RAM access is also possible through a system interface even in the RGB-I/F mode. In the RGB interface mode, data are written to RAM in synchronization with the DOTCLK during ENABLE = "Low". When writing data in the RGB-I/F mode through the system interface, it is necessary to set the ENABLE "High" to stop writing through the RGB interface. After accessing to RAM through the system interface, wait an enough time for the write/read bus cycle before starting accessing to RAM through the RGB interface. When RAM accesses through the RGB and system interfaces conflict, there will be no guarantee that data are properly written to RAM.

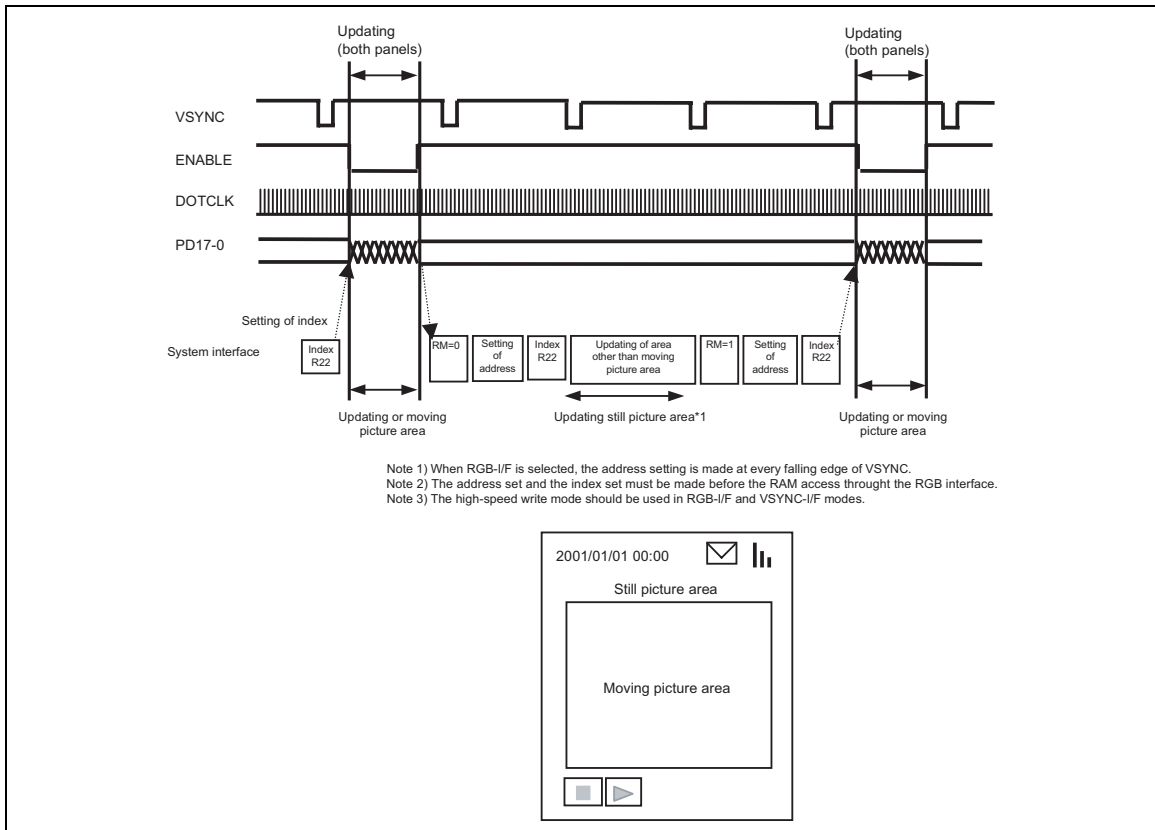

**Updating Still Picture Area during Displaying a Moving Picture**



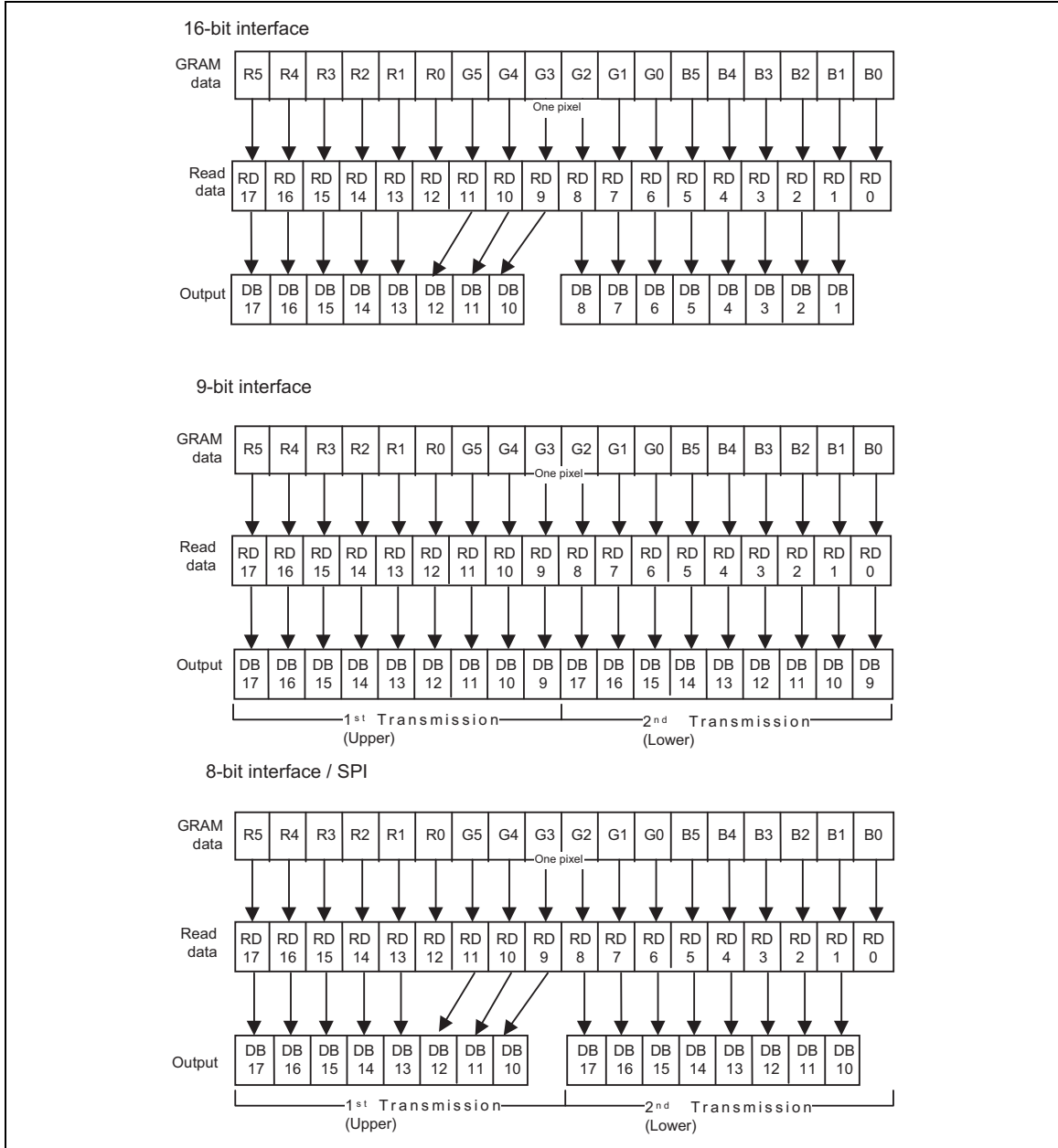

Read data from GRAM: Bit assignment

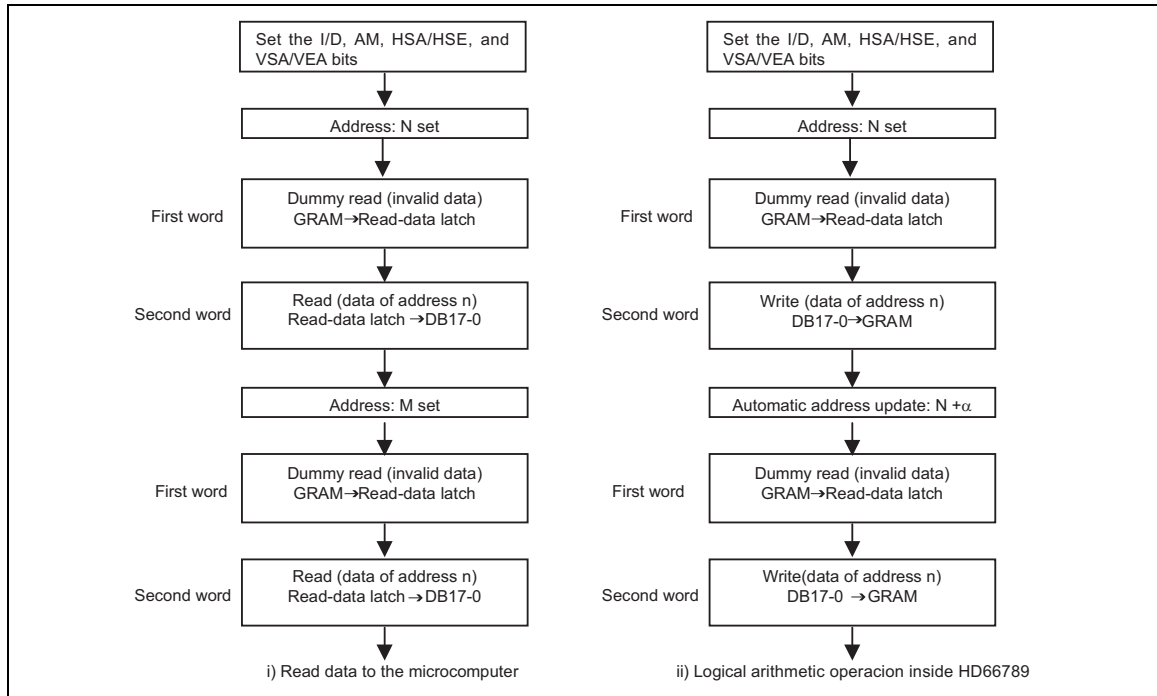

**GRAM read sequence**

**RAM Write Data Mask (R23h)**

**RAM Write Data Mask (R24h)**

R/W	RS	IB15	IB14	IB13	IB12	IB11	IB10	IB9	IB8	IB7	IB6	IB5	IB4	IB3	IB2	IB1	IB0
W	1	0	0	WM <sub>11</sub>	WM <sub>10</sub>	WM <sub>9</sub>	WM <sub>8</sub>	WM <sub>7</sub>	WM <sub>6</sub>	0	0	WM <sub>5</sub>	WM <sub>4</sub>	WM <sub>3</sub>	WM <sub>2</sub>	WM <sub>1</sub>	WM <sub>0</sub>
W	1	0	0	0	0	0	1	1	1	0	1	WM <sub>17</sub>	WM <sub>16</sub>	WM <sub>15</sub>	WM <sub>14</sub>	WM <sub>13</sub>	WM <sub>12</sub>

**WM17-0:** Write-mask the data when they are written to GRAM by bit. For example, if WM17 = 1, the WM17 write-mask the MSB of the data to write to GRAM so that the data in the MSB are not written to GRAM. The rest of WM16-0 bits also write-mask the data in the corresponding bits when these bits are set to “1”. For details, see the “Graphics Operation Function” section.

The WM17-0 bits write-mask the data to write to GRAM, which are expanded, if necessary, into 18 bits. This function is not available in the RGB-I/F mode.

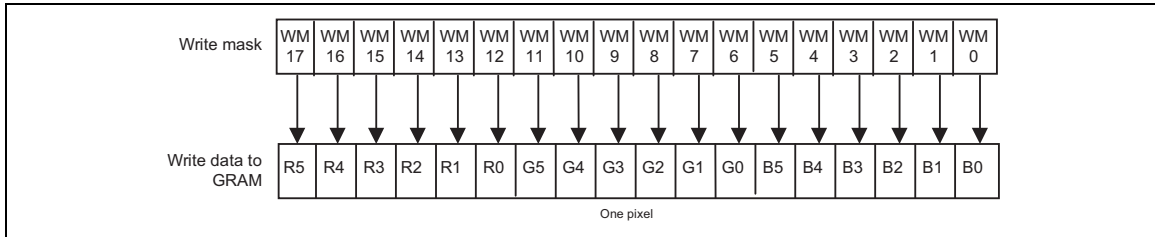

**RAM write data mask**

**$\gamma$  Control (R30h to R39h)**

	R/W	RS	IB15	IB14	IB13	IB12	IB11	IB10	IB9	IB8	IB7	IB6	IB5	IB4	IB3	IB2	IB1	IB0
R30	W	1	0	0	0	0	0	PKP 12	PKP 11	PKP 10	0	0	0	0	0	PKP 02	PKP 01	PKP 00
R31	W	1	0	0	0	0	0	PKP 32	PKP 31	PKP 30	0	0	0	0	0	PKP 22	PKP 21	PKP 20
R31	W	1	0	0	0	0	0	PKP 52	PKP 51	PKP 50	0	0	0	0	0	PKP 42	PKP 41	PKP 40
R33	W	1	0	0	0	0	0	PRP 12	PRP 11	PRP 10	0	0	0	0	0	PRP 02	PRP 01	PRP 00
R34	W	1	0	0	0	0	0	PKN 12	PKN 11	PKN 10	0	0	0	0	0	PKN 02	PKN 01	PKN 00
R35	W	1	0	0	0	0	0	PKN 32	PKN 31	PKN 30	0	0	0	0	0	PKN 22	PKN 21	PKN 20
R36	W	1	0	0	0	0	0	PKN 52	PKN 51	PKN 50	0	0	0	0	0	PKN 42	PKN 41	PKN 40
R37	W	1	0	0	0	0	0	PRN 12	PRN 11	PRN 10	0	0	0	0	0	PRN 02	PRN 01	PRN 00
R38	W	1	0	0	0	VRP 14	VRP 13	VRP 12	VRP 11	VRP 10	0	0	0	0	VRP 03	VRP 02	VRP 01	VRP 00
R39	W	1	0	0	0	VRN 14	VRN 13	VRN 12	VRN 11	VRN 10	0	0	0	0	VRN 03	VRN 02	VRN 01	VRN 00

**$\gamma$  Control Instructions**

- PKP52-00 : The  $\gamma$  fine adjustment registers for positive polarity.
- PRP12-00 : The  $\gamma$  gradient adjustment registers for positive polarity.
- PKN52-00 : The  $\gamma$  fine adjustment registers for negative polarity.
- PRN12-00 : The  $\gamma$  gradient adjustment registers for negative polarity.
- VRP14-00 : The amplitude adjustment registers for positive polarity.
- VRN14-00 : The amplitude adjustment registers for negative polarity.

For details, see the “ $\gamma$  adjustment” section.



**Gate Scan Position (R40h)**

R/W	RS	IB15	IB14	IB13	IB12	IB11	IB10	IB9	IB8	IB7	IB6	IB5	IB4	IB3	IB2	IB1	IB0
W	1	0	0	0	0	0	0	0	0	0	0	0	SCN4	SCN3	SCN2	SCN1	SCN0

**SCN4-0:** Specify the position where the gate driver scan starts. Make an optimum setting for the gate driver in use.

**SC Bits and Gate scan start position**

SCN4	SCN3	SCN2	SCN1	SCN0	Scan Start Position	
					GS = 0	GS = 1
0	0	0	0	0	G1	G240
0	0	0	0	1	G9	G232
0	0	0	1	0	G17	G224
.	.	.	.	.	.	.
1	1	0	1	0	G209	G32
1	1	0	1	1	G217	G24
1	1	1	0	0	G225	G16

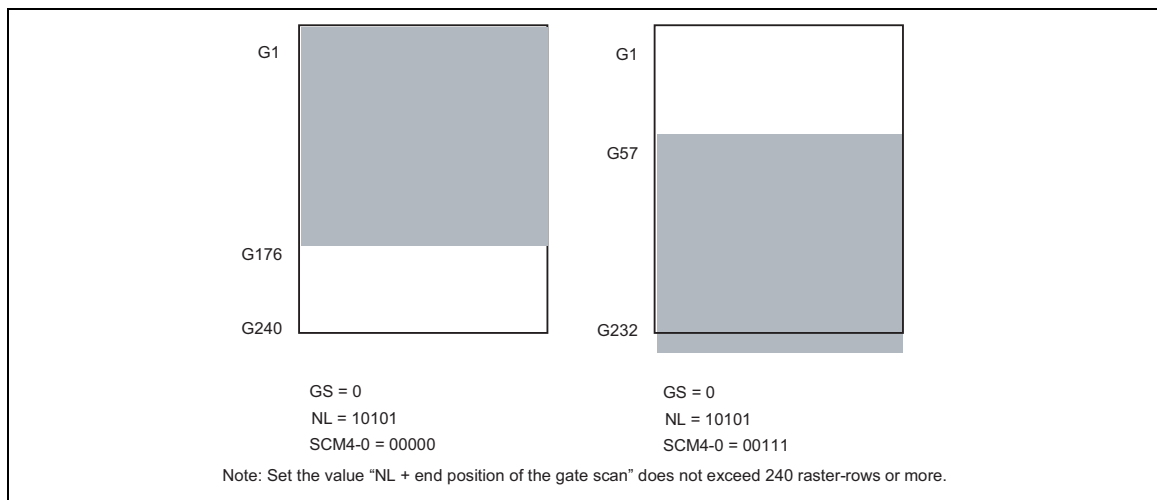

**Vertical Scroll Control (R41h)**

R/W	RS	IB15	IB14	IB13	IB12	IB11	IB10	IB9	IB8	IB7	IB6	IB5	IB4	IB3	IB2	IB1	IB0
W	1	0	0	0	0	0	0	0	0	VL7	VL6	VL5	VL4	VL3	VL2	VL1	VL0

**VL7–0:** Specify the number of raster-rows that are scrolled and control smooth scrolling in the vertical direction. The number of raster-rows is specified from 0 to 240. The raster-rows of the specified number are scrolled during display. When the 240th raster-row is displayed, the scrolling display starts afresh from the 1st raster-row. The number of raster-rows that are scrolled (VL7–0) can be specified when the first screen vertical scroll enable bit VLE1 = 1 or the second screen vertical scroll enable bit VLE2 = 1. The number of raster-rows is fixed (not changeable) when VLE2-1 = 00. This function is not available in the external display interface mode.

**VL Bits and Display-start Raster-row**

VL7	VL6	VL5	VL4	VL3	VL2	VL1	VL0	Amount of Scrolling (Number of raster-row)
0	0	0	0	0	0	0	0	0 raster-row
0	0	0	0	0	0	0	1	1 raster-row
0	0	0	0	0	0	1	0	2 raster-rows
:	:	:	:	:	:	:	:	:
1	1	1	0	1	1	1	0	238 raster-rows
1	1	1	0	1	1	1	1	239 raster-rows

Note: When setting the number of raster-rows for scrolling, it must be 239 or less.

**1st-Screen Drive Position (R42h)****2nd-Screen Drive Position (R43h)**

R/W	RS	IB15	IB14	IB13	IB12	IB11	IB10	IB9	IB8	IB7	IB6	IB5	IB4	IB3	IB2	IB1	IB0
W	1	SE17	SE16	SE15	SE14	SE13	SE12	SE11	SE10	SS17	SS16	SS15	SS14	SS13	SS12	SS11	SS10
W	1	SE27	SE26	SE25	SE24	SE23	SE22	SE21	SE20	SS27	SS26	SS25	SS24	SS23	SS22	SS21	SS20

**SS17–10:** Specify the start position for driving the first screen by line. The liquid crystal is driven by from the gate driver of “the set value + 1”.

**SE17–10:** Specify the end position for driving the first screen by line. The liquid crystal is driven by to the gate driver of “the set value + 1”. For instance, when SS17–10 = “07”H and SE17–10 = “10”H, the liquid crystal is driven from G8 to G17, and black display is driven from G1 to G7, and G18 thereafter. Make sure that SS17–10 ≤ SE17–10 ≤ “EF”H. For details, see the “Screen-split Drive Function” section.

**SS27-20:** Specify the start position for driving the second screen by line. The liquid crystal is driven by from the gate driver of “the set value + 1”. The second screen is driven when SPT = 1.

**SE27-20:** Specify the end position for driving the second screen by line. The liquid crystal is driven by to the gate driver of “the set value + 1”. For instance, when SPT = 1, and SS27-20 = “20”H, SE27-20 = “4F”H, the liquid crystal is driven from G33 to G80. Make sure that SS17-10 ≤ SE17-10 < SS27-20 ≤ SE27-20 ≤ “EF”H. For details, see the “Screen-split Drive Function” section.

**Horizontal RAM Address Position (R44h)**

**Vertical RAM Address Position (R45h)**

R/W	RS	IB15	IB14	IB13	IB12	IB11	IB10	IB9	IB8	IB7	IB6	IB5	IB4	IB3	IB2	IB1	IB0
W	1	HEA7	HEA6	HEA5	HEA4	HEA3	HEA2	HEA1	HEA0	HSA7	HSA6	HSA5	HSA4	HSA3	HSA2	HSA1	HSA0
W	1	VEA7	VEA6	VEA5	VEA4	VEA3	VEA2	VEA1	VEA0	VSA7	VSA6	VSA5	VSA4	VSA3	VSA2	VSA1	VSA0

**HSA7-0/HEA7-0:** Specify the start/end positions of the window-address range in the horizontal direction by address. Data are written to GRAM within the area determined by the addresses specified by HEA7-0 and HSA7-0. These addresses must be set before RAM write. In setting these bits, make sure that “00”h ≤ HSA7-0 ≤ HEA7-0 ≤ “AF”h.

**VSA7-0/VEA7-0:** Specify the start/end positions of the window-address range in the vertical direction by address. Data are written to GRAM within the area determined by the addresses specified by VEA7-0 and VSA7-0. These addresses must be set before RAM write. In setting these bits, make sure that “00”h ≤ VSA7-0 ≤ VEA7-0 ≤ “EF”h.

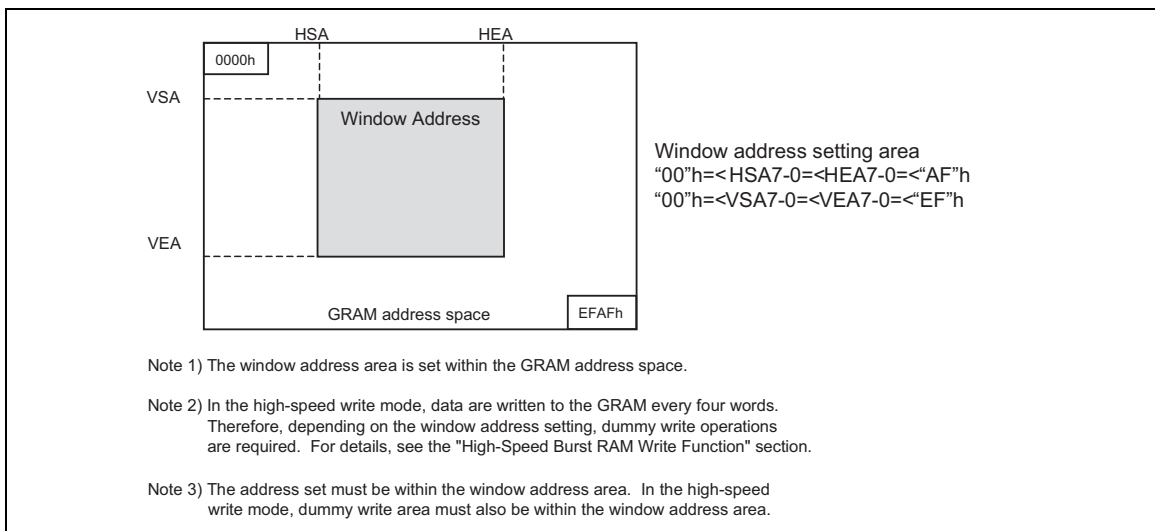

**GRAM address area and window-address range**



## Reset Function

The HD66789 makes internal initialization with RESET input. During RESET, the HD66789 is in a busy state, and no instruction from the MPU and access to GRAM are accepted. The time required for the RESET input is at least 1ms. In case of power-on reset, wait at least 10ms after the power is turned on until the R-C oscillation frequency becomes stabilized. While waiting, do not make an initial setting for the instruction set or an access to GRAM.

### Initial State of Instructions

- a. Start oscillation
- b. Driver output control (NL4-0 = "11101", SS = "0", SM = "0", EPL = "0", DPL = "0", HSPL = "0", VSPL = "0", GS = "0", SM = "0")
- c. Liquid crystal AC drive control (FLD1-0 = "01", B/C = "0", EOR = "0", NW5-0 = "00000")
- d. Entry mode set (HWM = "0", I/D1-0 = "11": Increment by 1, AM = "0": Horizontal direction, LG2-0 = "000": Replace mode, BGR = "0", TRI = "0", DFM1-0 = "00")
- e. Compare register (CP17-0 : "00 0000 0000 0000 0000")
- f. Display control 1 (PT1-0 = "00", VLE2-1 = "00": No vertical scroll, SPT = "0", FRCP = "0", DTE = "0", CL = "0": 65,536-color mode, REV = "0", D1-0 = "00": Display OFF, GON = 0)
- g. Display control 2 (BP3-0 = "1000", FP3-0 = "1000")
- h. Display control 3 (PTG1-0 = "00", ISC3-0 = "0000")
- i. Frame cycle control (NO1-0 = "00", SDT1-0 = "00", EQ1-0 = "00": No equalization, DIV1-0 = "00": clock/1, RTN3-0 = "0000": 16 clocks in 1H period)
- j. External display interface (RIM1-0 = "00": 18-bit RGB interface, DM1-0 = "00": internal clock operation, RM = "0": System interface)
- k. Power control 1 (SAP2-0 = "000", BT2-0 = "000", AP2-0 = "000": liquid crystal power supply off, DK = "1": DCDC1 off, SLP = "0", STB = "0": Standby mode off)
- l. Power control 2 (DC12-0 = "000", DC02-00 = "000", VC2-0 = "000")
- m. Power control 3 (PON = "0", VRH3-0 = "00000")
- n. Power control 4 (VCOMG = "0", VDV4-0 = "00000", VCM4-0 = "00000")
- o. RAM address set (AD15-0 = "0000"H)
- p. RAM write data mask (WM17-0 = "18'h00000": No mask)
- q.  $\gamma$  control  
(PKP02-00 = "000", PKP12-10 = "000", PKP22-20 = "000", PKP32-30 = "000",  
PKP42-40 = "000", PKP52-50 = "000", PRP02-00 = "000", PRP12-10 = "000")  
(PKN02-00 = "000", PKN12-10 = "000", PKN22-20 = "000", PKN32-30 = "000",  
PKN42-40 = "000", PKN52-50 = "000", PRN02-00 = "000", PRN12-10 = "000")  
(VRP14-10 = "00000", VRP03-00 = "0000", VRN14-10 = "00000", VRN12-10 = "000")
- r. Gate scan starting position (SCN4-0 = "00000")
- s. Vertical scroll (VL7-0 = "00000000")
- t. 1st split-screen (SE17-10 = "11111111", SS17-10 = "00000000")
- u. 2nd split-screen (SE27-20 = "11111111", SS27-20 = "00000000")
- v. Horizontal RAM address position (HEA7-0 = "10000011", HSA7-0 = "00000000")
- w. Vertical RAM address position (VEA7-0 = "10101111", VSA7-0 = "00000000")

**GRAM Data Initialization**

The data in GRAM are not initialized by the RESET input. Initialize through software during the display OFF (D1-0 = "00").

**Initial state of Output Pins**

- a. Liquid crystal driver output pins (source outputs): Output GND level
- b. Oscillator output pin (OSC2): Outputs oscillation signal

## Interface Specifications

The HD66789 incorporates a system interface to make settings for instructions, and an external display interface to display moving pictures. By selecting an optimum interface for display (moving or still picture, or both), data are transmitted efficiently.

The external display interfaces are RGB-I/F and VSYNC-I/F. Through these interfaces, the data can be updated without flickering the moving picture on the display.

In the RGB-I/F mode, the display operation is performed in synchronization with the signals (VSYNC, HSYNC, and DOTCLK). The display data are written according to the values of the data enable signal (ENABLE), data valid signal (VLD) and PD17-0 bits in synchronization with VSYNC, HSYNC, and DOTCLK signals. The display data are written to GRAM to reduce the data transmission to minimum, i.e. only when the displays are being updated. With the window address function, only the RAM area used for moving picture display is overwritten, and therefore the simultaneous display of moving picture area, which is overwritten, and the RAM data in the area other than the moving picture area, which is not overwritten, is possible. In the RGB and VSYNC interface modes, write data to GRAM in the high speed write mode (HWM = 1) while displaying moving pictures to make an access to GRAM in high speed with low power consumption.

In the VSYNC interface mode, internal display operations are synchronized with the frame-synchronizing signal (VSYNC). By writing data in synchronization with the falling edge of VSYNC at a fixed speed to GRAM through a system interface, it enables moving pictures display with a system interface. In this case, there are some constraints in the RAM writing speed and method.

The HD66789 handles the following 4 operational modes for the type of display. The setting can be made through an external display interface. A transition between the modes must follow the transition flow.

**Operation modes and interfaces**

Operation Mode	RAM Access Setting (RM)	Display Operation Mode (DM1-0)
Internal operating clock only (Displaying still pictures)	System interface (RM = 0)	Internal operating clock (DM1-0 = 00)
RGB interface (1) (Displaying moving pictures)	RGB interface (RM = 1)	RGB interface (DM1-0 = 01)
RGB interface (2) (Rewriting still pictures while displaying moving pictures)	System interface (RM = 0)	RGB interface (DM1-0 = 01)
VSYNC interface (Displaying moving pictures)	System interface (RM = 0)	VSYNC interface (DM1-0 = 10)

Note 1) the instruction register setting can be made only through a system interface.

Note 2) The RGB-I/F and VSYNC-I/F are not compatible with each other.

Note 3) Do not change the setting for RGB-I/F mode (RIM-0) while RGB I/F is in operation.

Note 4) See the “External Display Interface” section for the transition flow of each operation mode.

Note 5) In the RGB-I/F and VSYNC-I/F modes, write data in the high speed write mode (HWM = 1).

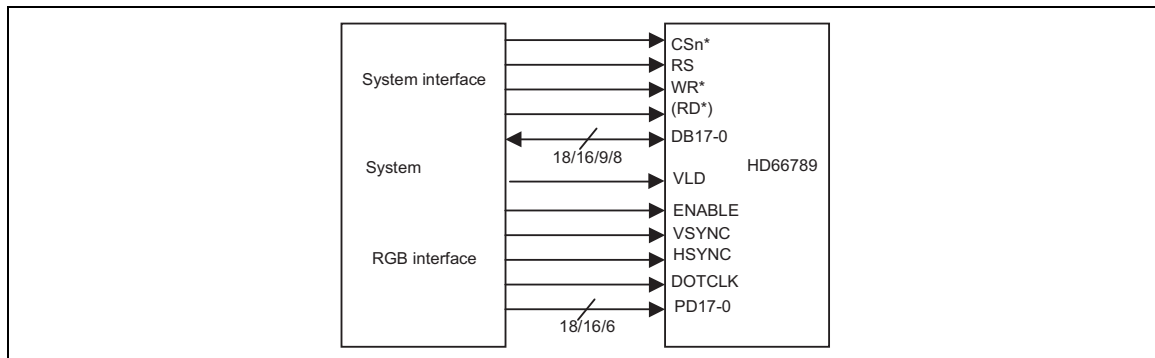

**Interfaces and HD66789**



## System Interface

The following shows the kinds of system interfaces and the IM pins setting for selecting an interface. The instruction setting and RAM access are made through a system interface.

### IM bits setting and the type of system interface

IM3	IM2	IM1	IM0	MPU-Interface Mode	DB Pin
0	0	0	0	Setting disabled	
0	0	0	1	Setting disabled	
0	0	1	0	80-system 16-bit interface	DB17 to 10 and 8-to-1
0	0	1	1	80-system 8-bit interface	DB17 to 10
0	1	0	*	Serial peripheral interface (SPI)	SDI, SDO
0	1	1	*	Setting disabled	
1	0	0	0	Setting disabled	
1	0	0	1	Setting disabled	
1	0	1	0	80-system 18-bit interface	DB17 to 0
1	0	1	1	80-system 9-bit interface	DB17 to 9
1	1	*	*	Setting disabled	

**80-system 18-bit interface**

80-system 18-bit parallel data transmission becomes operable by setting IM3/2/1/0 pins to IOVcc/GND/IOVcc/GND levels respectively.

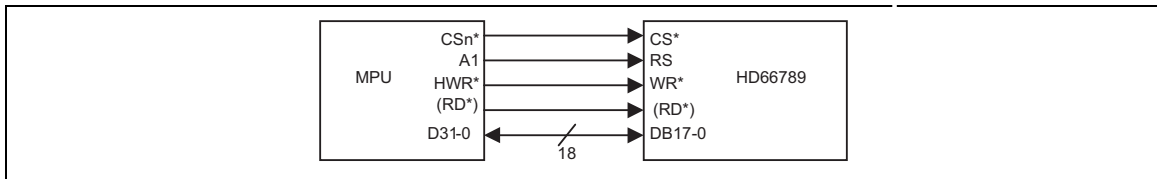

**18-bit microcomputer and HD66789**

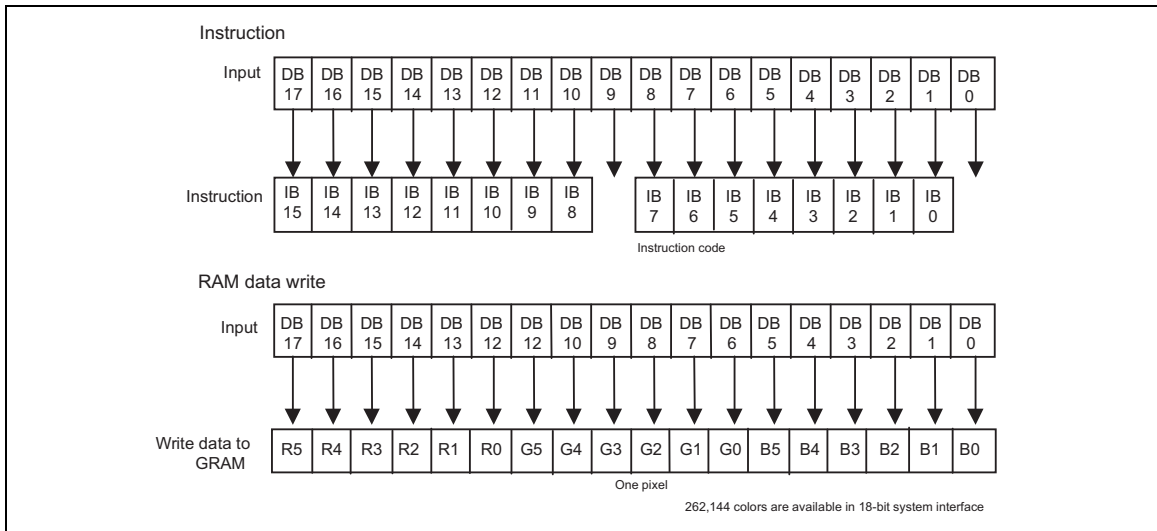

**Data format for 18-bit interface**

**80-system 16-bit interface**

The 80-system 16-bit parallel data transmission becomes operable by setting IM3/2/1/0 pins to GND/GND/IOVcc/GND levels respectively.

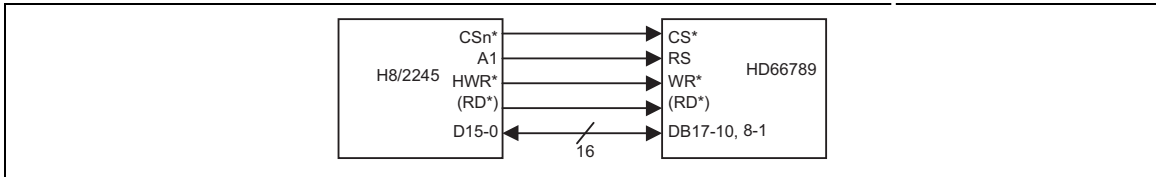

**16-bit microcomputer and HD66789**

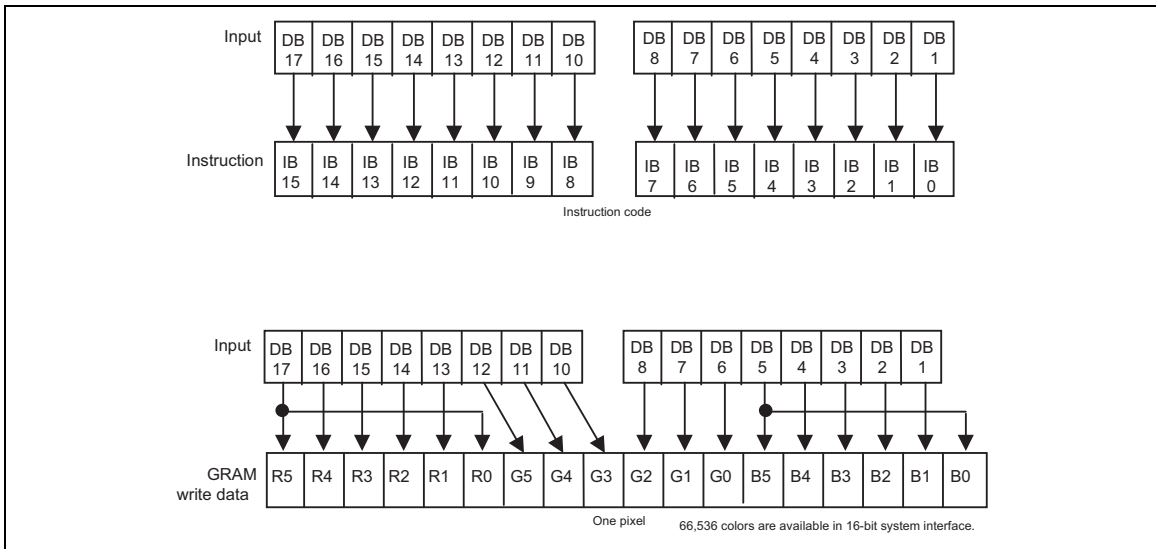

**Data format for 16-bit interface**

**80-system 9-bit interface**

The 80-system 9-bit parallel data transmission becomes operable by setting IM3/2/1/0 pins to IOVcc/GND/IOVcc/IOVcc levels respectively. When transmitting a 16-bit instruction, it is divided into upper and lower 8 bits (the LSB is not used) and the upper 8 bits are transmitted first. The RAM data is also divided into the upper and lower 9 bits, and the upper bits are transmitted first. The unused pins DB8-0 must be fixed to either IOVcc or GND level. When writing into the index register, the upper byte (8 bits) must be written.

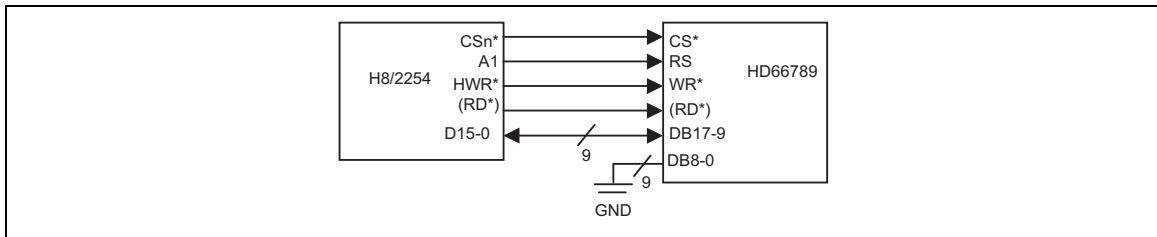

**9-bit microcomputer and HD66789**

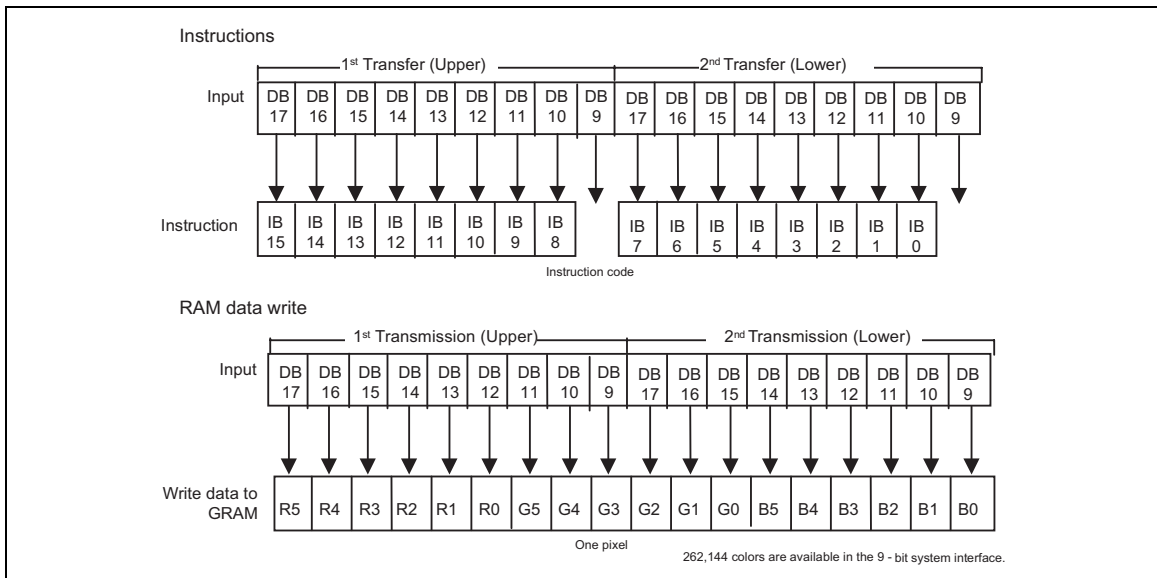

**Data format for 9-bit interface**

**Data transmission synchronizing in 9-bit bus interface mode**

The HD66789 supports a data transmission synchronizing function, which resets the upper/lower counter that counts the number of transmission of upper/lower 9-bit data in the 9-bit bus interface mode. When a discrepancy occurs in the upper/lower 9-bit data transmission due to effects from noise and so on, the “00” H instruction is written 4 times consecutively to forcibly reset the upper/lower counter so that data transmission restarts with an upper 9-bit data transmission. The excursion can be recovered by executing the synchronizing function periodically.

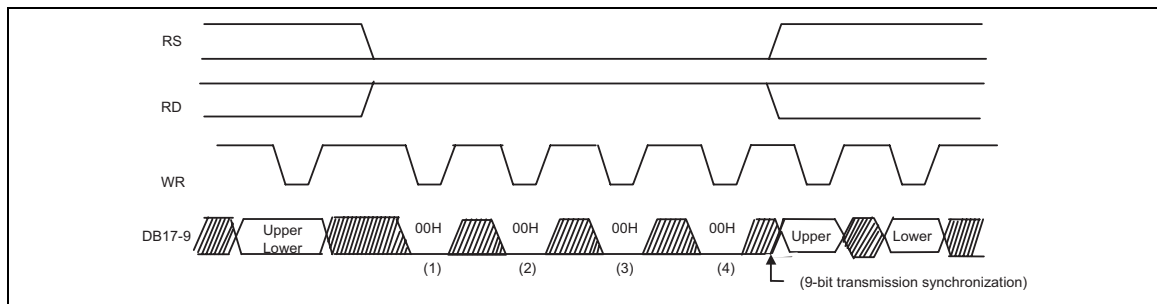

**9-bit data transmission synchronization**

**80-system 8-bit interface**

The 80-system 8-bit parallel data transmission becomes operable by setting IM3/2/1/0 pins to GND/GND/IOVcc/IOVcc levels respectively. When transmitting a 16-bit instruction, it is divided into upper and lower 8 bits and the upper 8 bits are transmitted first. The RAM data is also divided into the upper and lower 8 bits, and the upper bits are transmitted first. The data to write to RAM are expanded into 18 bits internally. The unused pins DB9-0 must be fixed to either IOVcc or GND level. When writing into the index register, the upper byte (8 bits) must be written.

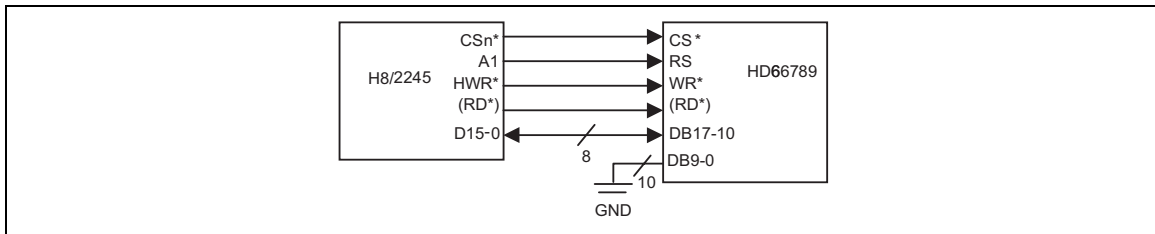

**8-bit microcomputer and HD66789**

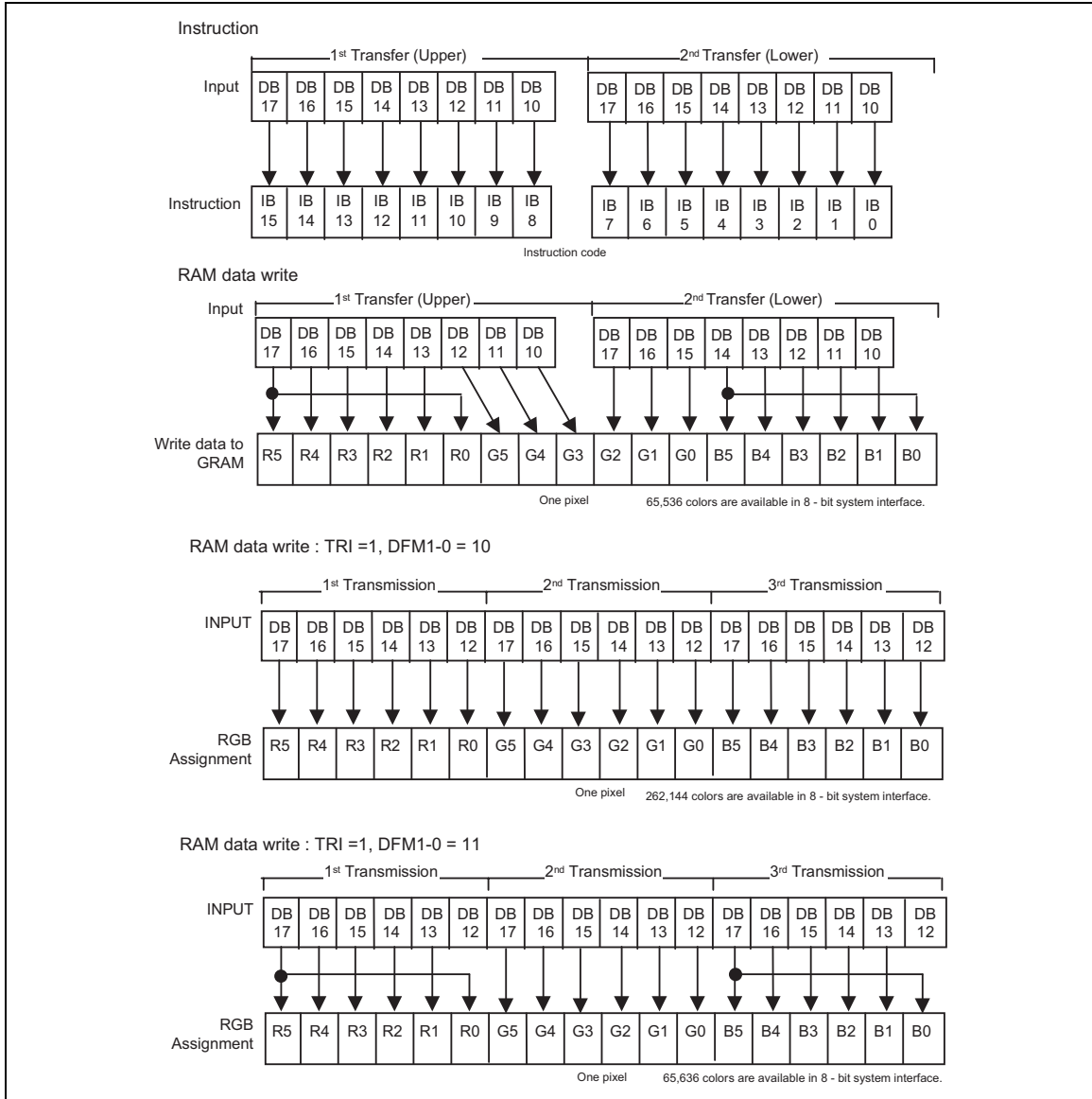

Data format for 8-bit interface

**Data transmission synchronizing in 8-bit bus interface mode**

The HD66789 supports a data transmission synchronizing function, which resets the upper/lower counter that counts the number of transmission of upper/lower 8-bit data in the 8-bit bus interface mode. When a discrepancy occurs in the transmission of upper/lower 8-bit data due to effects from noise and so on, the “00” H instruction is written 4 times consecutively to forcibly reset the upper/lower counter so that data transmission restarts with the upper 8-bit transmission. The excursion can be recovered by executing the synchronizing function periodically.

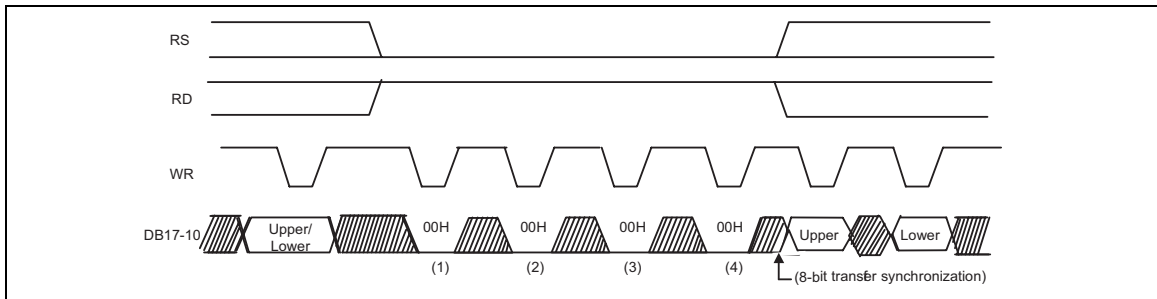

**8-bit data transmission synchronization**



**Serial Peripheral interface (SPI)**

The Serial Peripheral Interface (SPI) becomes operable by setting IM3/2/1 pins to GND/IOVcc/GND levels respectively. The SPI is available through the chip select line (CS\*), serial transfer clock line (SCL), serial data input (SDI), and serial data output (SDO). In the SPI mode, the IM0/ID pin functions as ID pin. In the SPI mode, the unused DB15-2 pins must be fixed at either IOVcc or GND level.

The HD66789 recognizes the start of data transfer at the falling edge of CS\* input to initiate the transfer of start byte. It recognizes the end of data transfer at the rising edge of CS\* input. The HD66789 is selected when the 6-bit chip address in the start byte transferred from the transmission device and the 6-bit device identification code assigned to the HD66789 are compared and both 6-bit data correspond. When selected, the HD66789 starts taking in the subsequent data string. The setting for the least significant bit of the identification code is made with the ID pin. The five upper bits of the identification code must be 01110. Two different chip addresses must be assigned to the HD66789 because the seventh bit of the start byte is assigned to a register select bit (RS). When RS = 0, index register write or status read is executed. When RS = 1, instruction write or RAM read/write is executed. The eighth bit of the start byte is to specify read or write (R/W bit). The data are received when the R/W bit is 0, and are transmitted when the R/W bit is 1.

In the SPI mode, the data are written to GRAM after two-byte data transmission. The data are expanded into 18 bits by adding one bit (the same data as the MSB of RB) next to the LSB of RB data.

After receiving the start byte, the HD66789 starts to transmit or receive data by byte. The data transmission adopts a format by which the MSB is first transmitted. All HD66789 instructions consist of 16 bits and they are executed internally after two bytes are transmitted with the MSB first (DB15 to 0). The data to write to RAM are expanded into 18-bit data. After the start byte is received, the first byte is always fetched as the upper eight bits of the instruction and the second byte is fetched as the lower eight bits of the instruction. The 4-byte data that are read from RAM right after the start byte are made invalid. The HD66789 reads as valid data from the 5th-byte data.

**Start Byte Format**

Transmitted bits	S	1	2	3	4	5	6	7	8
Start byte format	Transmission start	Device ID code						RS	R/W
		0	1	1	1	0	ID		

Note 1) ID bit is selected with the IM0/ID pin.

**RS and R/W Bit Function**

RS	R/W	Function
0	0	Set index register
0	1	Read status
1	0	Write instruction or RAM data
1	1	Read instruction or RAM data

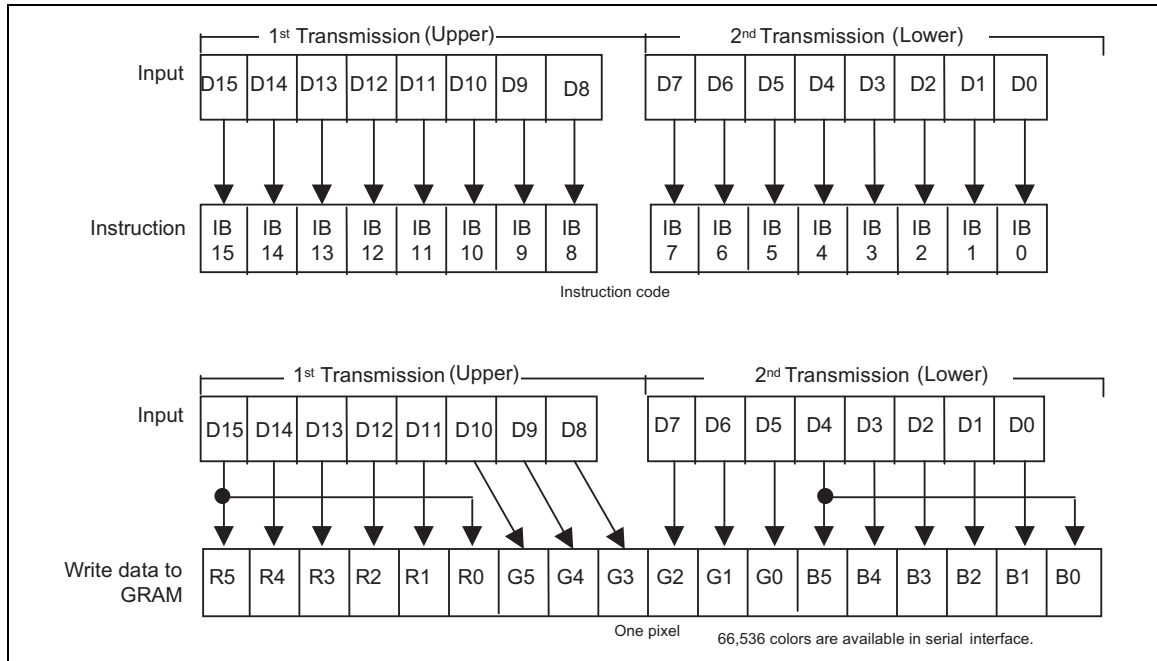

Data format for SPI

A) Basic data transmission through SPI

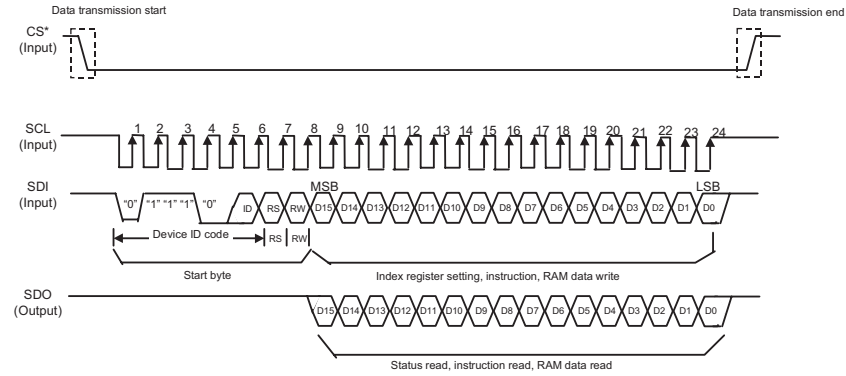

B) Consecutive data transmission through SPI

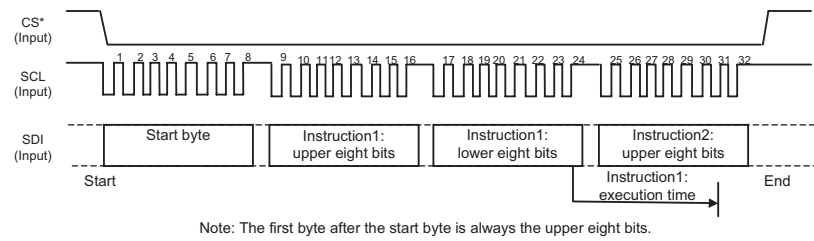

C) RAM data read transmission

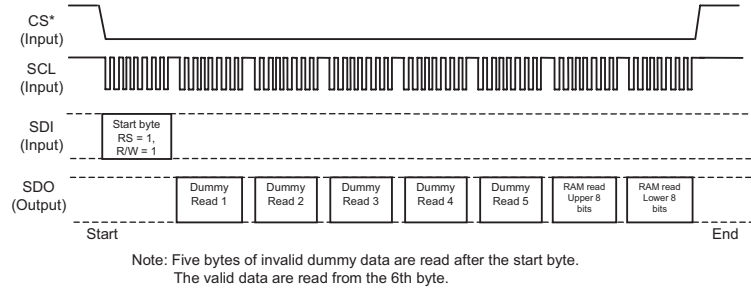

D) Status read / instruction read

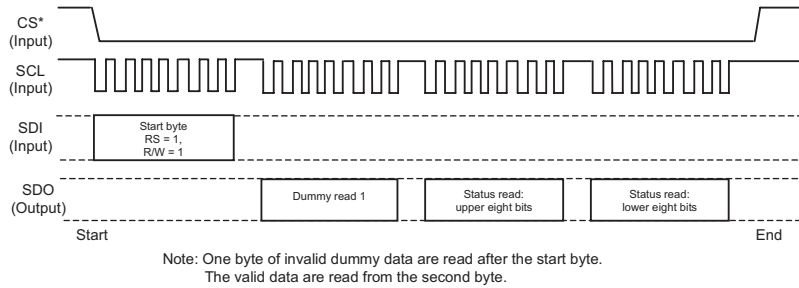

Data transmission through Clock-Synchronized Serial Bus Interface

**VSYNC Interface**

The HD66789 incorporates a VSYNC-I/F, which enables moving picture display with only a system interface and the frame-synchronizing signal (VSYNC). This interface enables moving picture display with minimum modification to a conventional system.

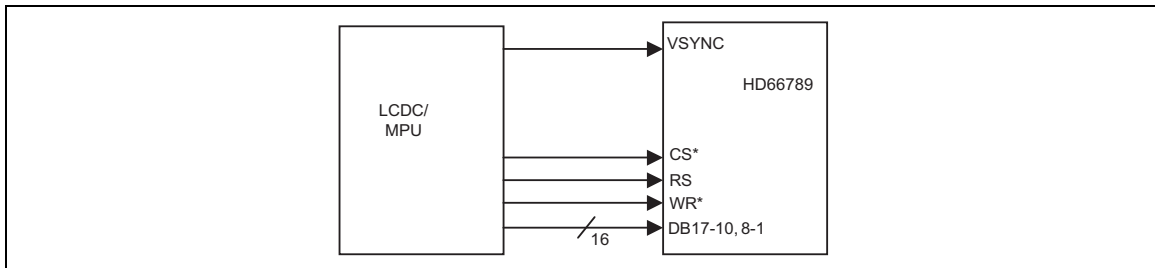

**VYSNC interface**

The VSYNC-I/F becomes operable by setting DM1-0 = 10 and RM = 0. In the VSYNC I/F mode, the internal display operations are synchronized with VSYNC. By writing data to RAM through a system interface in a speed that is higher for more than a fixed speed than the internal display operation speed, it enables moving picture display through a system interface, while preventing flickers while the screens are being updated.

Display operations are executed by the internal clock generated by the internal oscillator and VSYNC input. All display data are stored in RAM. This enables moving picture display only by transmitting data that are written over, thereby minimizing the number of data transmission while displaying moving picture. The high-speed write mode (HWM = 1) enables RAM access in high speed with low power consumption.

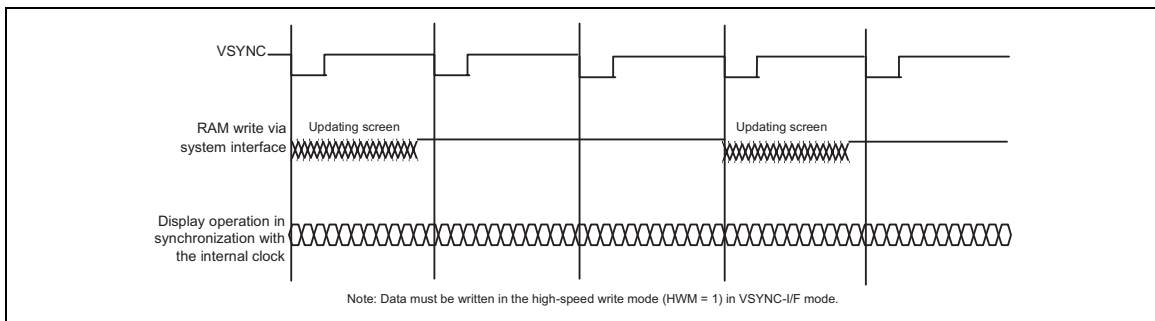

**Moving picture data transmission through VSYNC interface**

The VSYNC-I/F has limits on the minimum speed for RAM write through a system interface and the frequency of the internal clock. It requires RAM write speed more than the result that is calculated from the following formula.

- Internal clock frequency (fosc) [Hz] = Frame frequency × (Display line (NL) + Front porch (FP) + Back porch (BP)) × 16 clocks × Fluctuation
- Minimum speed for RAM write (min.) [Hz] > 176 × Display line (NL) / {(Back porch (BP) + Display raster-row (NL) - Margin) × 16 clocks} / fosc}

Note 1) When RAM write does not start right after the falling edge of VSYNC, the time between the falling edge of VSYNC and the start of RAM write must also be taken into account.

An example of the RAM write speed and the frequency of the internal clock in the VSYNC interface mode is as follows.

**[Example]**

Display size	176 RGB × 240 lines
Display line	240 lines (NL = 11110)
Back/front porch	14/2 lines (BP = 1110/FP = 0010)
Frame frequency	60 Hz

$$\text{Internal clock frequency (fosc) [Hz]} = 60 \text{ Hz} \times (240 + 2 + 14) \times 16 \text{ Clock} \times 1.1 / 0.9 = 300 \text{ kHz}$$

When calculating the internal clock frequency, possible causes of fluctuations must also be taken into consideration. The allowance for this fluctuation is ± 10 % from the center value, and the range of the frequency must be within VSYNC period.

As the causes of fluctuations, the above example takes the variation in the LSI fabrication and the room temperature into account. Other possible causes of fluctuations, such as variation in the external resistors or the voltage change are not considered in the above example. It is necessary to make a setting with enough margins to include the allowances for these factors.

$$\begin{aligned} & \text{Minimum speed for RAM writing [Hz]} \\ & > 176 \times 240 / \{(14 + 240 - 2) \text{ raster-rows} \times 16 \text{ clock}\} / 300 \text{ kHz} = 3.14 \text{ MHz} \end{aligned}$$

In this case, RAM write is performed in synchronization with the falling edge of VSYNC.

When the data for one frame are written to RAM completely, there must be more than 2 raster-rows of margin before the raster-rows driven for the display.

By writing data to RAM on the falling edge of VSYNC at the speed of 3.14 MHz or more, the data for the whole screen on RAM are overwritten before the display operation starts. Accordingly, the flicker due to updating moving picture data can be avoided while displaying a moving picture.

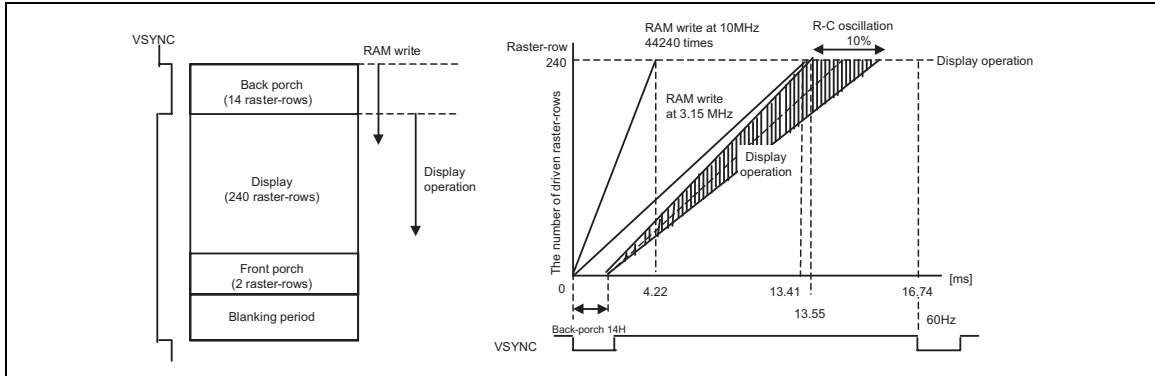

Operation through VSYNC interface

Notes to the VSYNC interface

1. The aforementioned example of calculation is just a result of calculation. In the actual settings, causes for the fluctuations of internal clocks and so on should be taken into consideration. It is necessary to make a setting for the RAM write speed with enough margins.
2. The aforementioned example of calculation is the value in case of writing over the entire screen. Limiting the area for the moving picture display will create more margins for the RAM write speed.

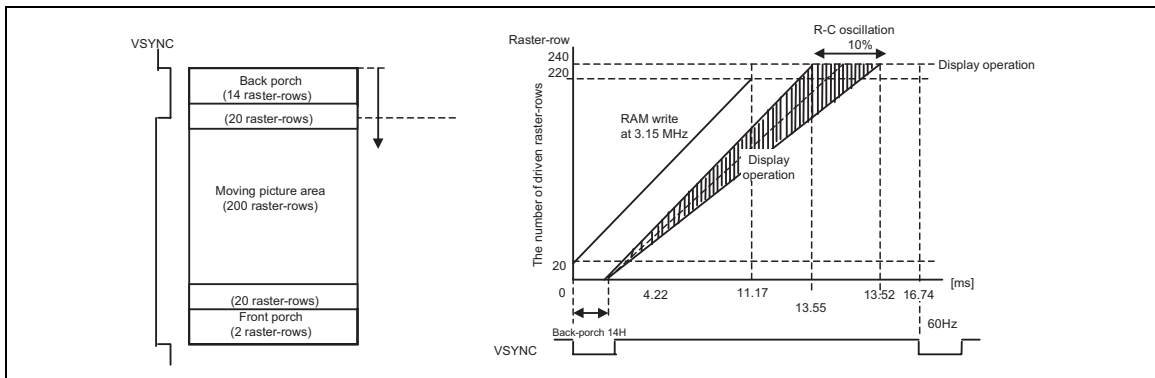

Limiting moving picture display area

3. A front porch period continues after the completion of 1 frame display and until the next input of VSYNC.
4. The transition between the internal clock operation mode (DM1-0 = 00) and the VSYNC interface mode becomes effective after displaying one frame made during instruction setting.
5. In the VSYNC interface mode, the partial display, vertical scroll, and interlaced drive functions are not available.
6. In the VSYNC interface mode, set AM to 0 to transmit display data in the aforementioned method.
7. In the VSYNC interface mode, write display data to RAM in the high speed write mode (HWM = 1)

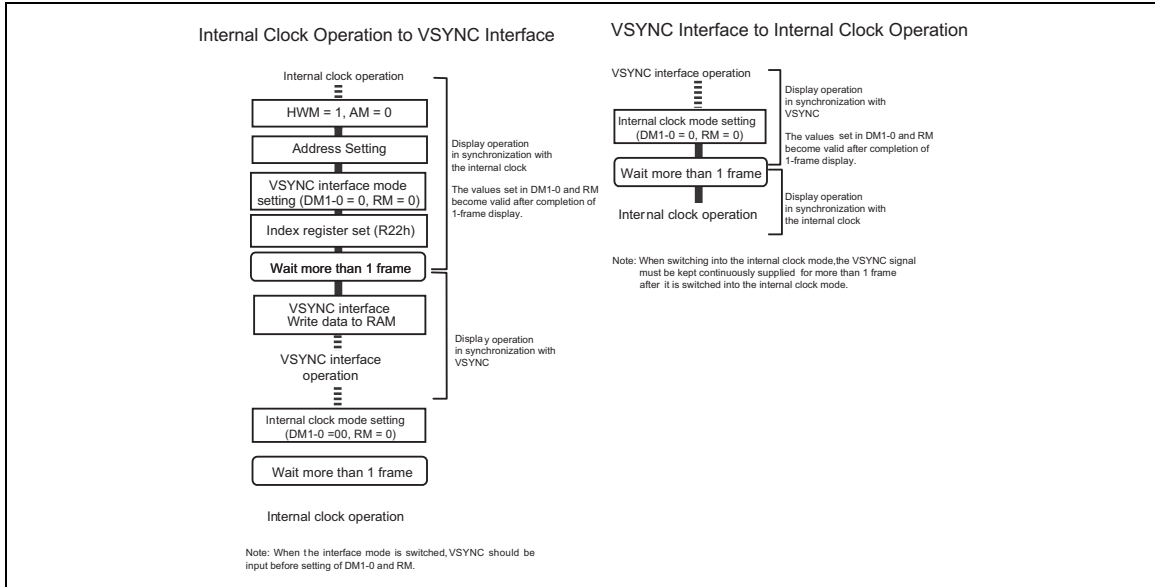

**Transition flow between VSYNC and internal clock operation modes**

### External Display Interface

The following interfaces are available as the external display interface (RGB interface). The interface is selected by setting RIM1-0 bits. RAM is accessible through the RGB interface.

#### RIM bits setting and RGB interface

RIM1	RIM0	RGB Interface	PD Pin
0	0	18-bit RGB interface	PD17-0
0	1	16-bit RGB interface	PD17-13, 11-1
1	0	6-bit RGB interface	PD17-12
1	1	Setting disabled	

Note 1) The use of multiple interfaces simultaneously is not possible.

#### RGB interface

Through the RGB-I/F, the display operation is performed in synchronization with VSYNC, HSYNC, and DOTCLK. The RGB interface enables data transmission with low power consumption by overwriting the area that needs update in high-speed write mode in combination with the window address function. The front and back porches must be set before and after the display period.

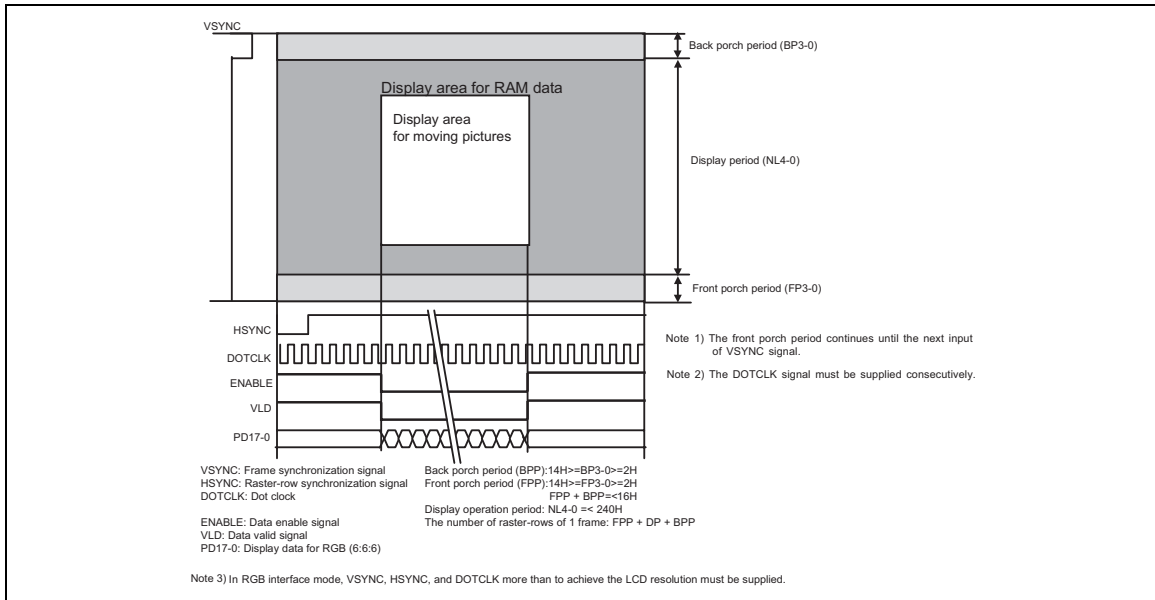

#### RGB interface



**VLD and ENABLE signals**

The relationship with the VLD and ENABLE signals is as follows. With the ENABLE signal, the addresses are not updated during data write, while with the VLD signal, the addresses are updated during data write when the ENABLE is “Low”. The polarity of the ENABLE signal is inverted by the setting of EPL bit.

EPL	ENABLE	VLD	RAM Write	RAM Address
0	0	0	Valid	Updated
0	0	1	Invalid	Updated
0	1	*	Invalid	Unchanged
1	0	*	Invalid	Unchanged
1	1	0	Valid	Updated
1	1	1	Invalid	Updated

**RGB interface timing**

The timing chart of 16/18-bit RGB interfaces is as follows.

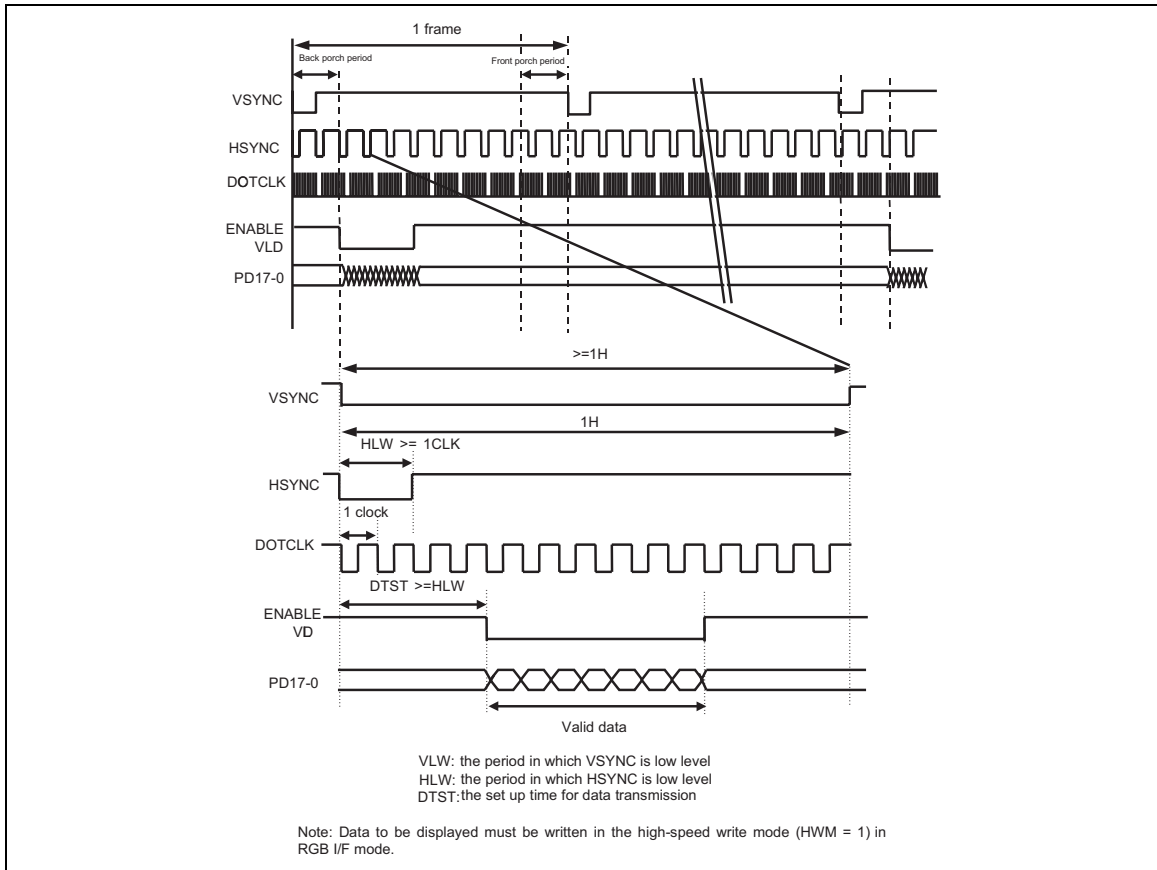

**16-/18-bit RGB Interface Timing**

The timing chart of 6-bit RGB interface is as follows.

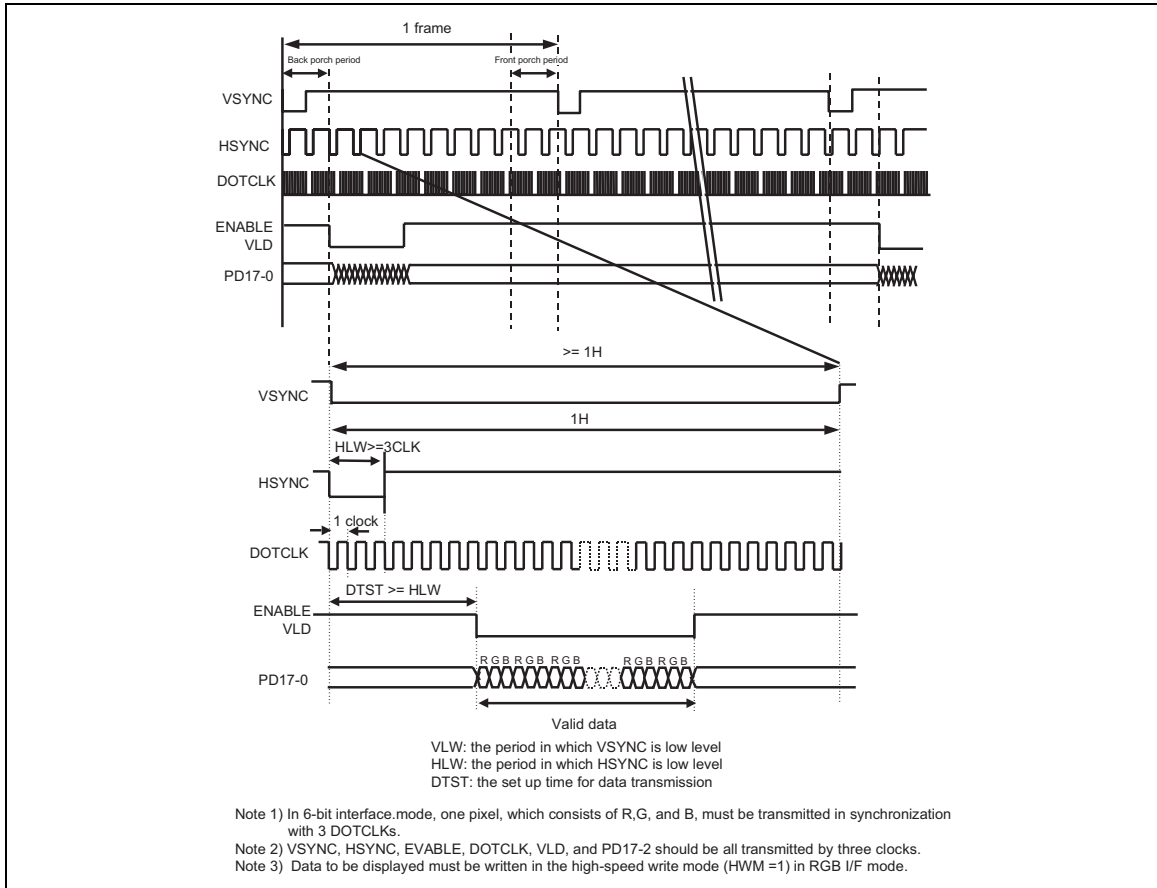

6-bit RGB Interface Timing

**Moving picture display**

The HD66789 incorporates the RGB interface to display moving pictures and RAM to store display data, which provides the following merits in displaying moving pictures.

- The window address function enables the transfer of only data for the moving picture area.
- The high-speed write mode enables high-speed access to RAM with low power consumption
- Only transmitting data that are written over the moving picture area.
- Reduced transmission contributes to the reduction of power consumption of the entire system.
- In combination with a system interface, the still picture area, such as an icon, can be updated while displaying moving pictures.

**RAM access through system interface in RGB-I/F mode**

RAM is accessible through a system interface in the RGB-I/F mode. In the RGB interface mode, data are being written to RAM in synchronization with the DOTCLK input while the ENABLE is “Low”. When writing data to RAM through the system interface, it is necessary to set ENABLE to “High” to stop data write through the RGB-I/F. Setting RM = 0 allows RAM access through the system interface. When reverting to the RGB interface mode, wait a write/read bus cycle. Then, set RM = 1 and the index to R22h to start RAM access through the RGB-I/F. When the RAM writes through the RGB and system interface conflicts, it is not guaranteed that the data are properly written to RAM.

The following is an example of moving picture display through the RGB-I/F and updating still picture area through the system interface.

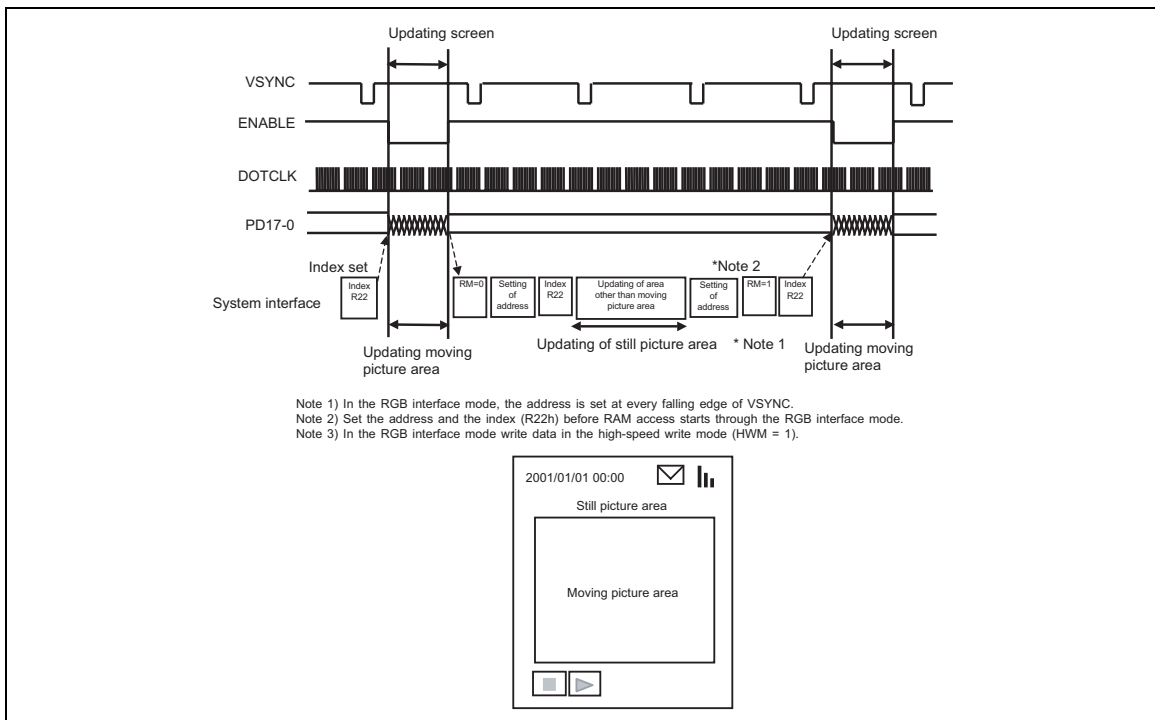

**Updating Still Picture Area during Displaying Moving Picture**

**6-bit RGB interface**

The 6-bit RGB interface is selected by setting RIM1-0 bits to 10. The display operation is synchronized with VSYNC, HSYNC, and DOTCLK signals. Display data are transmitted to RAM in synchronization with the display operation through 6-bit RGB data bus (PD17-12) according to data valid signal (VLD), and the data enable signal (ENABLE). Unused pins (PD11 to 0) must be fixed to either IOVcc or GND level.

The instructions are set only through a system interface.

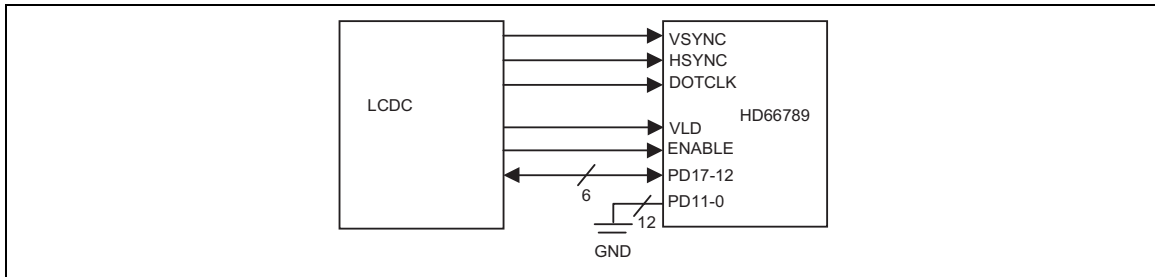

**6-bit RGB interface**

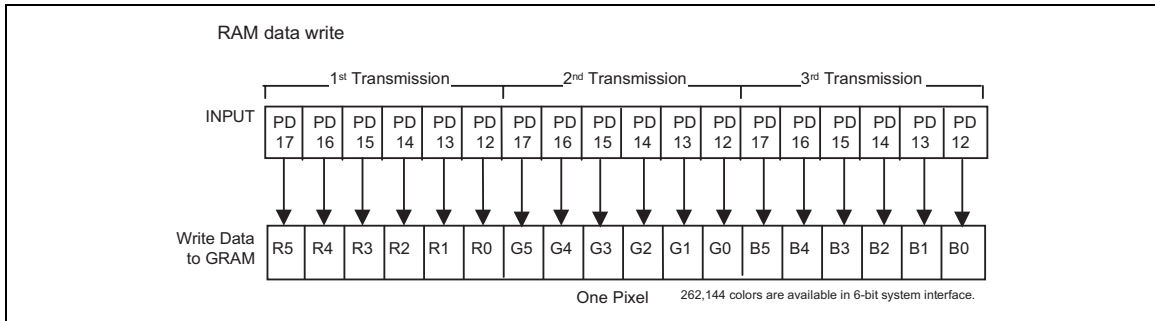

**Data format for 6-bit interface**

**Data transmission synchronization in 6-bit RGB interface mode**

The HD66789 incorporates a transmission counter to count the first, second, third data transmissions in the 6-bit RGB interface mode. The transmission counter is reset to the first transmission on the falling edge of VSYNC. When a discrepancy occurs in the transmission of first, second and third data, the counter is reset so that a first data transmission will be made at the start of each frame (on the falling edge of VSYNC) and the data transmission restarts in the correct order from the next frame. In case of displaying moving pictures, which requires consecutive data transfer, this function minimizes the effect from the discrepancy in the data transmission and makes it easy to return to the normal display.

The internal display operation is executed by pixel. Note that each DOTCLK input must correspond to a pixel. Otherwise data transmission discrepancies will occur and affect the displays of the current and ensuing frames.

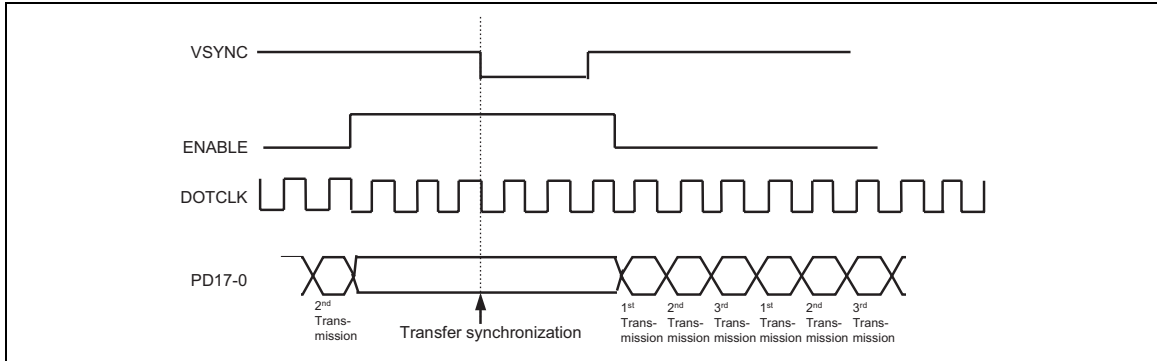

**6-bit data transmission synchronization**

**16-bit RGB interface**

The 16-bit RGB interface is selected by setting RIM1-0 bits to 01. The display operation is synchronized with VSYNC, HSYNC, and DOTCLK signals. Display data are transmitted to RAM in synchronization with the display operation through 16-bit RGB data bus (PD17-13, 11-1) according to the data valid signal (VLD), and the data enable signal (ENABLE).

The instructions are set only through a system interface.

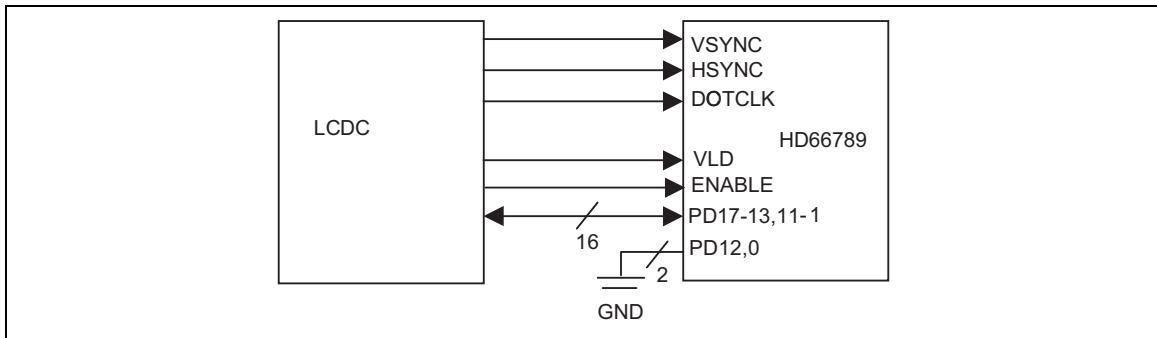

**16-bit RGB interface**

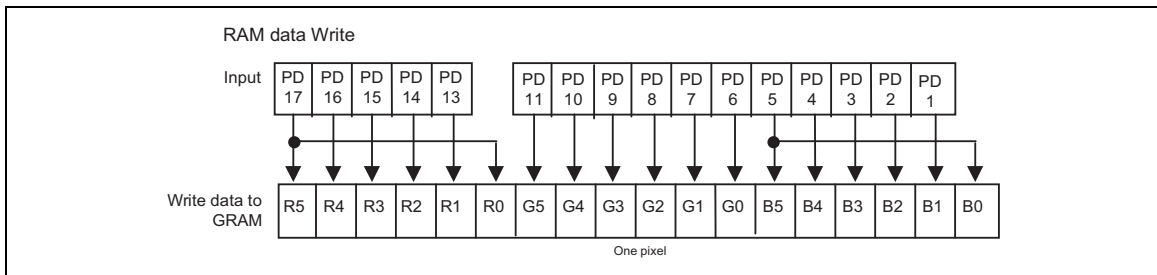

**Data format for 16-bit interface**

**18-bit RGB interface**

The 18-bit RGB interface is selected by setting RIM1-0 bits to 00. The display operation is synchronized with VSYNC, HSYNC, and DOTCLK signals. Display data are transmitted to RAM in synchronization with the display operation through 18-bit RGB data bus (PD17-0) according to the data valid signal (VLD), and the data enable signal (ENABLE).

The instructions are set only through a system interface.

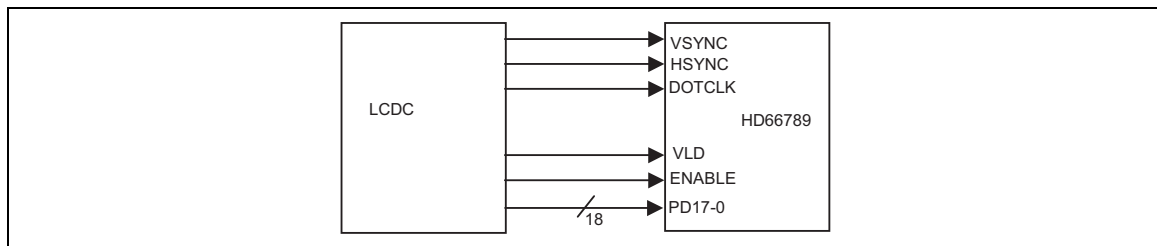

**18-bit RGB interface**

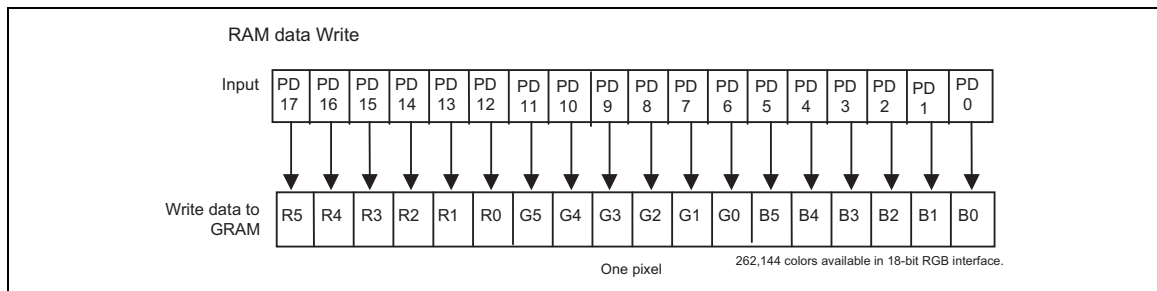

**Data format for 18-bit interface**

**Notes to the external display interface**

1. While an external display interface is selected, the following functions are not available.

Function	External Display Interface	Internal Display Operation
Partial display	Not available	Available
Scroll function	Not available	Available
Interlaced drive	Not available	Available
Graphics operation function	Not available	Available

2. The VSYNC, HSYNC, and DOTCLK signals must be supplied consecutively during display operation through the RGB-I/F.
3. When setting NO1-0, SDT1-0, and EQ1-0 bits in the RGB-I/F mode, the reference clock is the DOTCLK, not the internal operation clock.
4. In the 6-bit RGB-I/F mode, RGB (pixels) data are transmitted by three clocks. The data transmission, therefore, should be made by RGB.
5. In the 6-bit RGB-I/F mode, the interface signals, VSYNC, HSYNC, DOTCL, ENABLE, VLD, and PD17-0, should be set by RGB (pixels) in convenience for transmitting RGB pixels.
6. The transitions between the internal operation mode and external display interface should be made according to the mode switching sequence below.
7. In the RGB-I/F mode, the front porch period continues after displaying one frame data until the next VSYNC signal input.
8. In the RGB-I/F mode, the data must be written in the high-speed write mode (HWM = 1).
9. In the RGB-I/F mode, the address is set every frame on the falling edge of VSYNC.

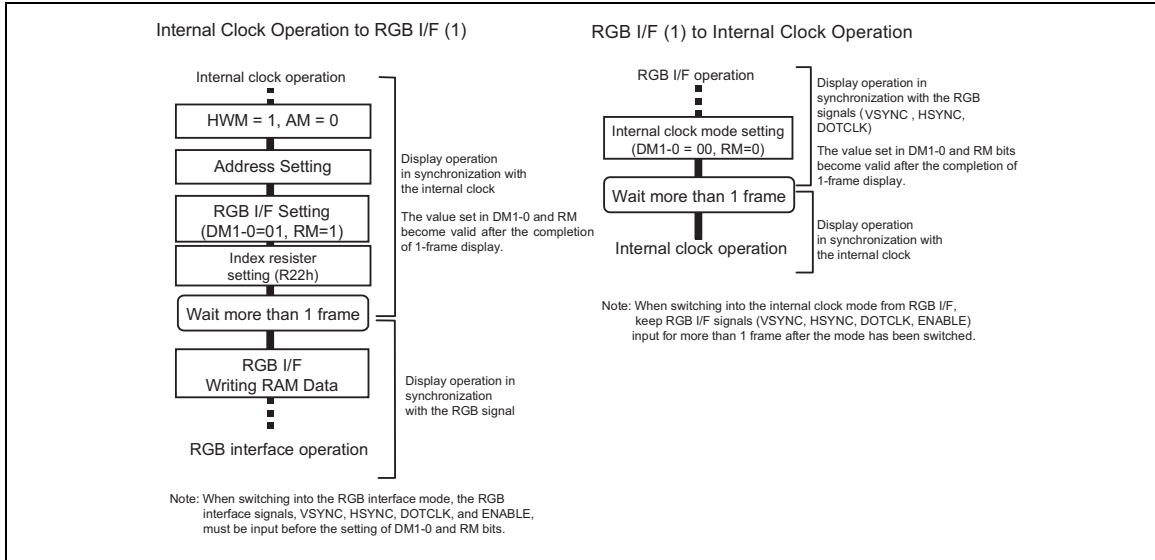

**Transition between the Internal Clock Operation Mode and RGB Interface Mode**

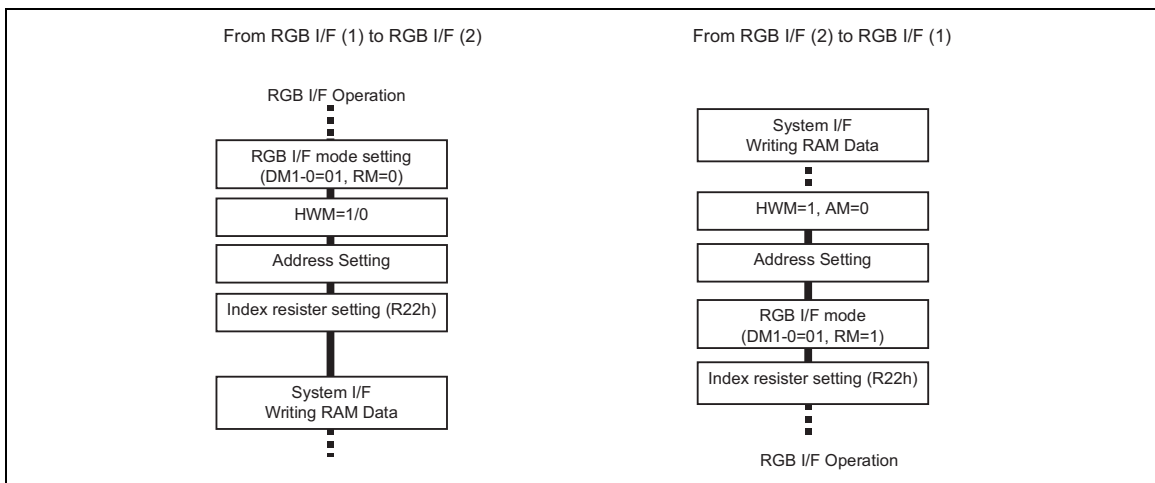

**RAM data write sequence through system interface in RGB-I/F mode**



### Timing Interfacing with Liquid Crystal Panel Signals

The relationship between RGB I/F signals and the liquid crystal panel signals in the RGB I/F mode is as follows.

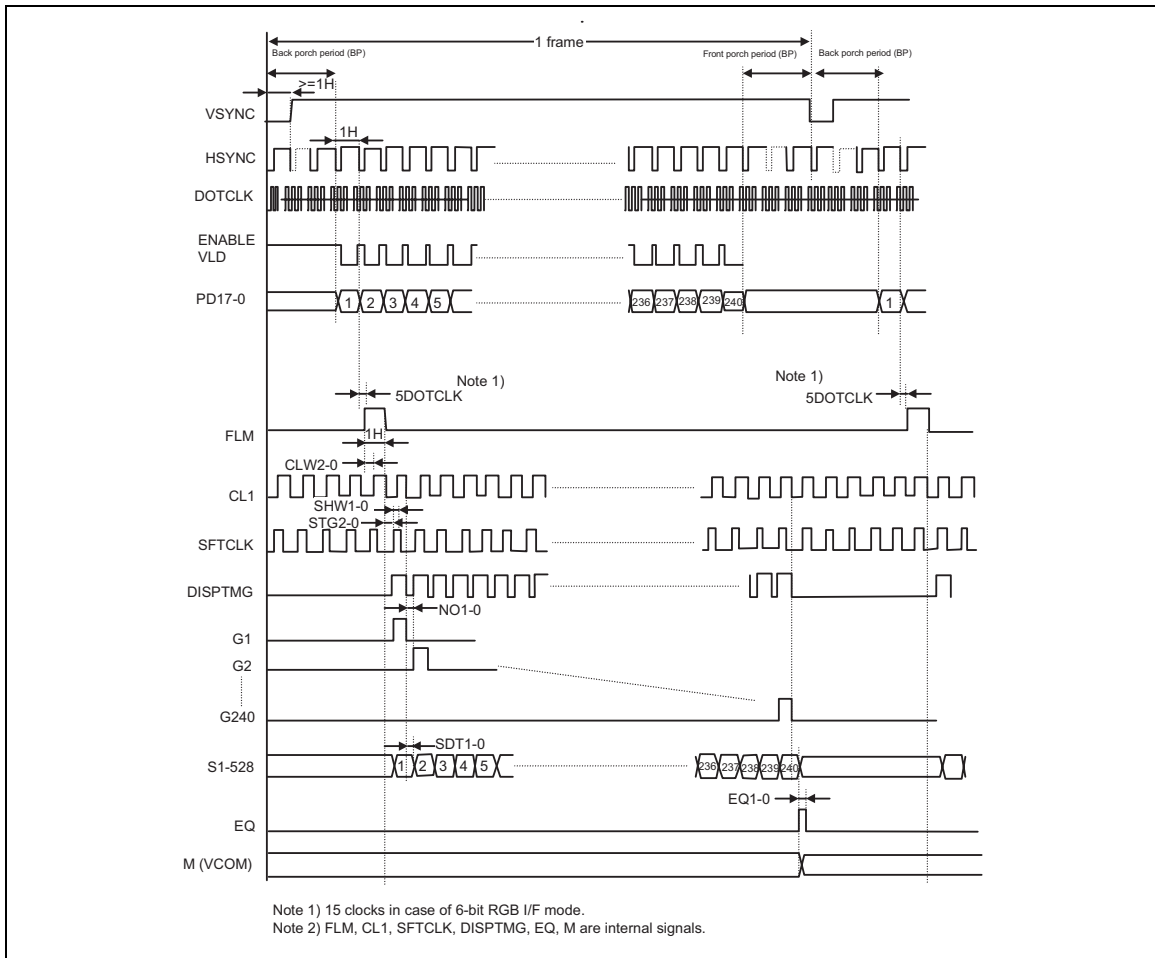

**Relationship between RGB I/F signal and the liquid crystal panel signal**

The timing interfacing with the liquid crystal panel signals in the internal clock operation mode is as follows.

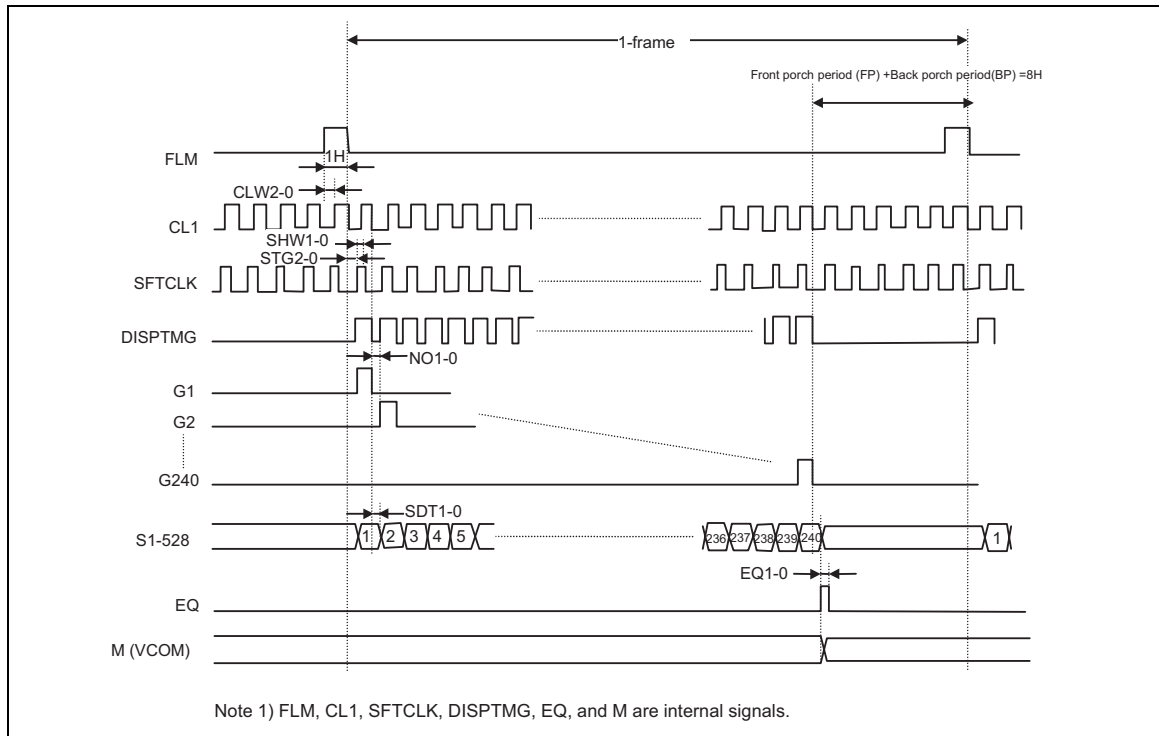

**Interfacing with the liquid crystal panel signals in the internal clock operation mode**

### Scan Mode Setting

The shift direction of gate signal is changeable by the combination of SM and GS bit settings. This allows various ways of connecting a liquid crystal panel and the HD66789.

SM	GS	Scan direction	
0	0		G1, G2, G3, G4,.... G237, G238, G239, G240
0	1		G240, G239, G238, G237,.... G4, G3, G2, G1
1	0		G1, G3, G5,.... G237, G239, G2, G4, G6,.... G238, G240
1	1		G240, G238, G236,.... G4, G2, G239, G237, G235,.... G3, G1

Scan mode setting

### High-Speed Burst RAM Write Function

The HD66789 incorporates high-speed burst RAM-write function, which writes data to RAM in one-fourth the access time required for a standard RAM-write operation. This function is especially useful for applications which require the high-speed rewrite of the display data such as display of colored moving picture and so on.

In the high-speed RAM write mode (HWM), data to write to RAM is temporarily stored to the internal register of HD66789. The data storage in the register is executed by word. When the data storage operation is executed 4 times, all data stored in the register are written to RAM at once. While the data is being written from the register to RAM, another set of data is being written to the register. This function enables high-speed and consecutive RAM write, which are required in displaying moving pictures and so on.

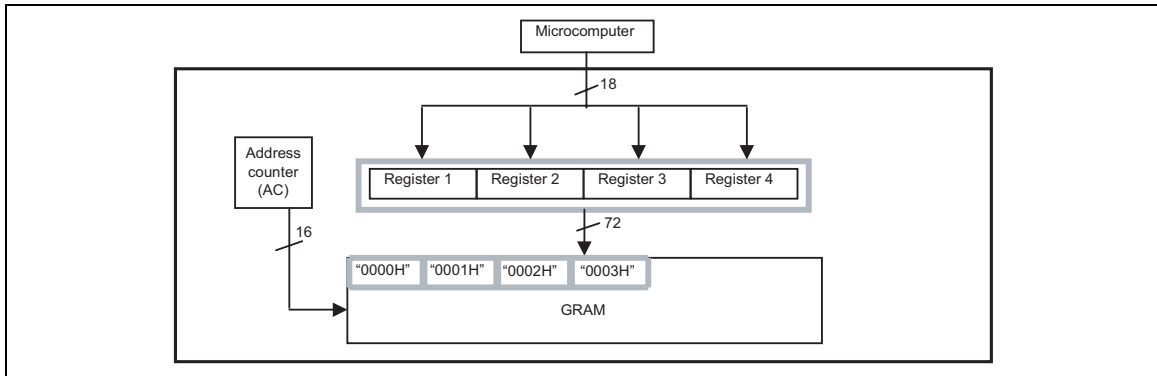

Operational flow of High-Speed Burst RAM Write

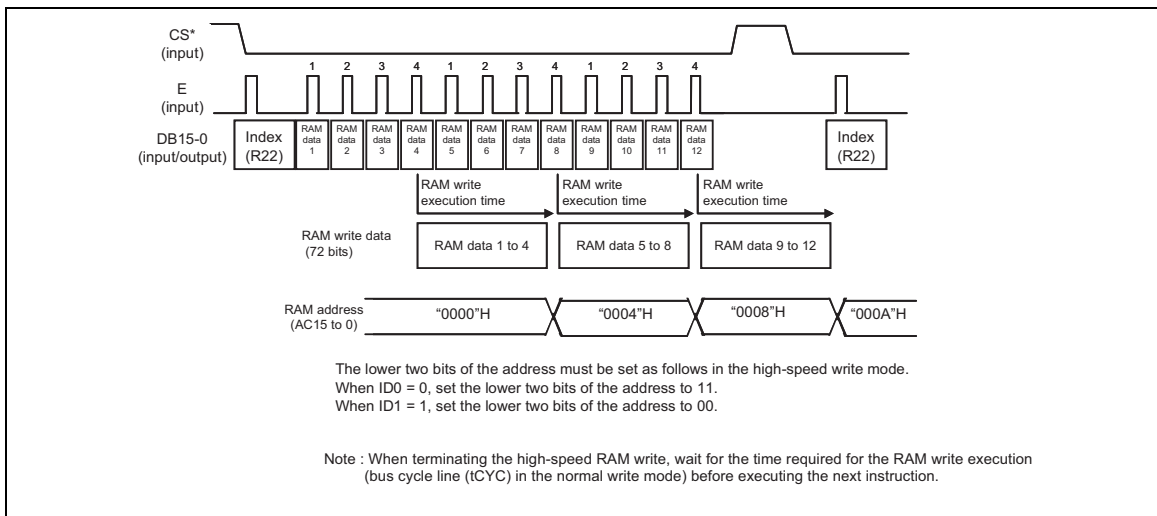

### High-Speed Consecutive Write to RAM

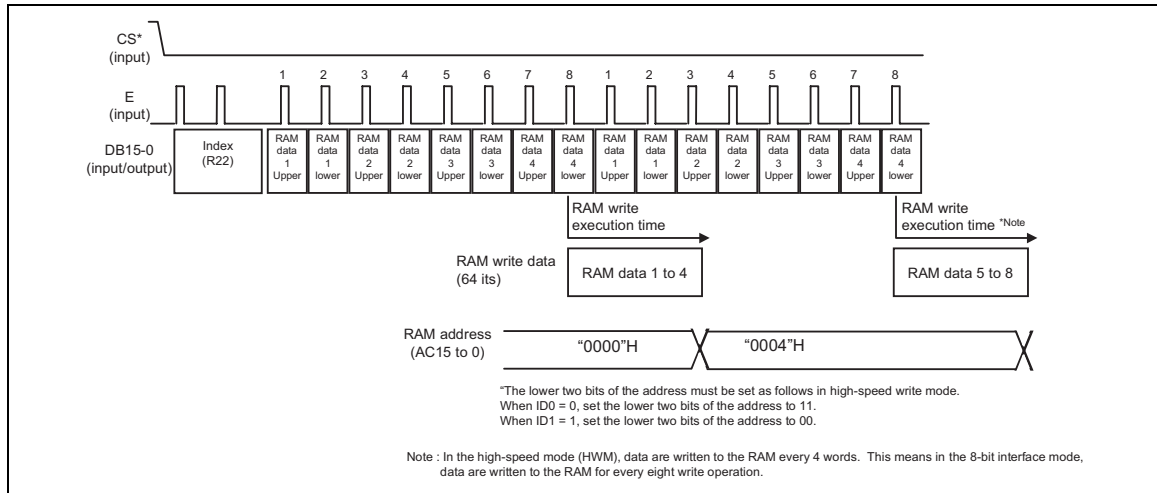

**Operation of High-Speed Consecutive Writing to RAM (8-Bit Interface)**

**Notes to the high-speed RAM write mode**

1. The logical/compare operations are not available.
2. The RAM write operation is executed every four words. Set the lower 2 bits of the addresses as follows when setting the address.
  - \*When ID0=0, the lower two bits in the address must be set to 11 before RAM write.
  - \*When ID0=1, the lower two bits in the address must be set to 00 before RAM write.
3. The RAM write operation is executed every four words. If the RAM write operation is terminated before all four-word data is written to RAM, the last data will not be written to RAM.
4. When the index register is set to R22H (RAM data write), the first RAM write operation is always executed. In this case, the RAM data read is not operable simultaneously. During RAM read, set the HWM to 0.
5. The high-speed RAM write mode is not compatible with the normal RAM write mode. When the mode must be switched to the other, make a new address set before starting RAM write.
6. When writing data in the high speed RAM write mode within the range specified with the window address, some window-address range may require dummy write operation. See "High-Speed RAM Write with Window Address Function".

---

**Comparison between Normal and High-Speed RAM Write Operations**

	<b>Normal RAM Write (HWM=0)</b>	<b>High-Speed RAM Write (HWM=1)</b>
Logical operation function	Available	Not available
Compare operation function	Available	Not available
BGR function	Available	Available
Write mask function	Available	Available
RAM address set	Specified by one word	ID0 bit=0: Set the lower two bits to 11 ID0 bit=1: Set the lower two bits to 00
RAM read	Read by one word	Not available
RAM write	Write by one word	Dummy write operations may be required depending on the specified window-address range
Window address	Set by one word	Horizontal range(HSA/HSE): more than four words Number of horizontal writing : 4N (N>=2)
External display interface	Available	Available
AM Setting	AM = 1/0	AM = 0

---

### High-Speed RAM Write with Window Address

To rewrite the data in an arbitrary rectangular area of RAM consecutively in high speed, the number of RAM access should be made 4 multiple times. Accordingly some window-address range may require dummy write operation to make the RAM access 4 multiple times. The number of dummy write is set when setting the window address as follows.

The horizontal window-address range specifying bits (HSA1-0, HEA1-0) specify the number of dummy write operations executed at the start and end of the data to write to RAM. The total RAM access must be 4 multiple times per line.

#### Number of Dummy Write Operations in High-Speed RAM Write (HSA Bits)

HSA1	HSA0	Number of Dummy Write Operations inserted
0	0	0
0	1	1
1	0	2
1	1	3

#### Number of Dummy Write Operations in High-Speed RAM Write (HEA Bits)

HEA1	HEA0	Number of Dummy Write Operations inserted
0	0	3
0	1	2
1	0	1
1	1	0

The number of RAM access when writing data in the horizontal direction must be made  $4 \times N$  times by including the dummy writes.

$$\text{Horizontal RAM write} = \text{start dummy write} + \text{write data} + \text{end dummy write} = 4 \times N \text{ (times)}$$

An example of RAM write in high speed RAM write mode with the window address is as follows.

The RAM data in the specified window-address range is written over consecutively in high speed by inserting two dummy writes at the start of the line and three dummy writes at the end of the line. The number of dummy writes is specified with the window-address range specifying bits. In this case, set HSA1-0 to 10, HEA1-0 to 00.

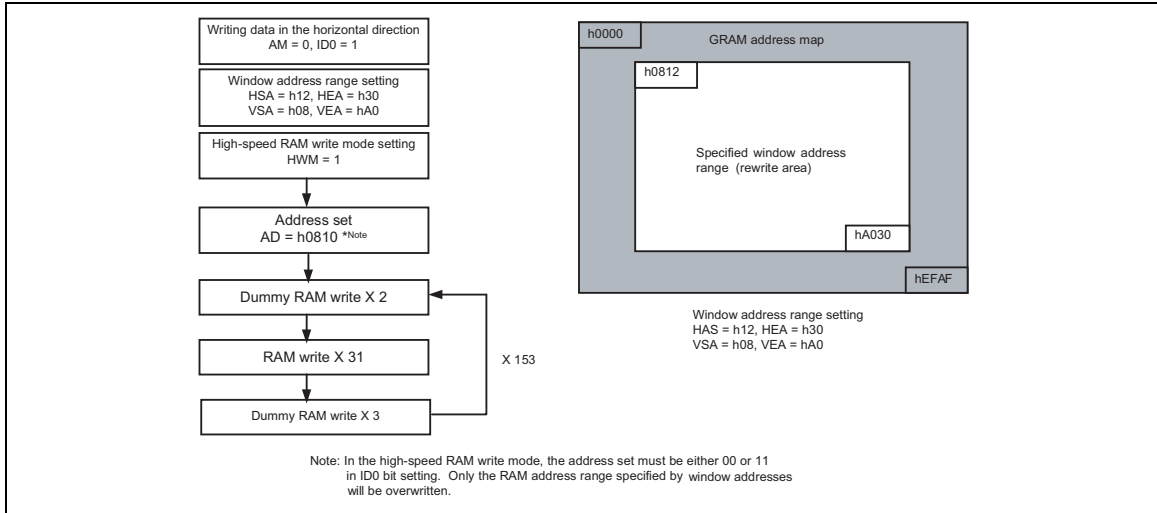

**High-Speed RAM Write with Window Address Function**



### Window Address Function

The window address function enables consecutive data write within the rectangular window-address area on the on-chip GRAM, which is specified with horizontal address registers (start: HSA7-0, end: HEA 7-0) and vertical address registers (start: VSA7-0, end: VEA7-0).

The address transition direction is determined with AM bits (either increment or decrement). Accordingly, the data, including picture data, are written consecutively without taking the data wrap position into consideration.

The window-address range must be specified within the GRAM address area. An address set must be set within the window-address range.

[Condition on setting window-address range]

(horizontal direction)	$00H \leq HSA7-0 \leq HSA7-0 \leq AFH$
(vertical direction)	$00H \leq VSA7-0 \leq VEA7-0 \leq EFH$

[Condition on making an address set within the window-address range]

(RAM address)	$HSA7-0 \leq AD7-0 \leq HEA7-0$
	$VSA7-0 \leq AD15-8 \leq VEA7-0$

Note: In high-speed RAM write mode, the lower two bits of the address must be set as follows.

- ID0=0: The lower two bits of the address must be set to 11.
- ID0=1: The lower two bits of the address must be set to 00.

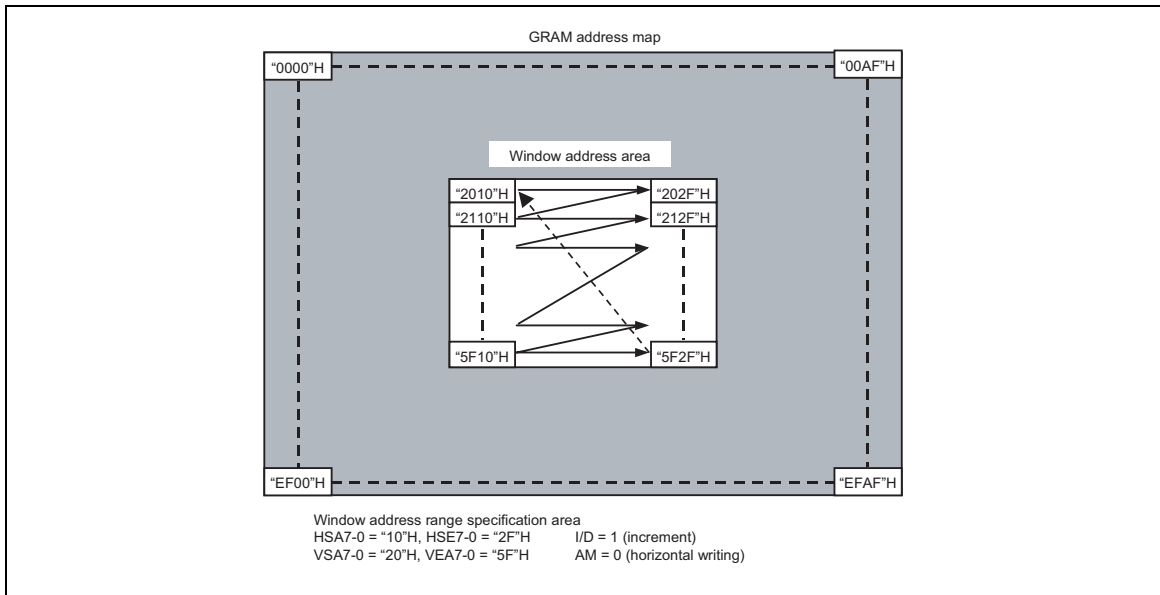

**Address transition direction in specified window-address range**

### Graphics Operation Function

The HD66789 greatly reduces the load on the graphics-processing software in the microcomputer with the 18-bit bus architecture and the graphics bit operation. The graphics bit operation includes:

1. The write data mask function that selectively rewrites some of the 18-bit write data.
2. The conditional rewrite function that compares the write data and the compare bit data and writes the data sent from the microcomputer only when the conditions are satisfied.

The graphics bit operation is controlled by setting bits in the entry mode register and RAM-write-data mask register, and the write operation from the microcomputer.

### Graphics Operation

Operation Mode	Bit Setting			Operation and Usage
	I/D	AM	LG2-0	
Write mode 1	0/1	0	000	Horizontal data replacement
Write mode 2	0/1	1	000	Vertical data replacement
Write mode 3	0/1	0	110 111	Conditional horizontal data replacement
Write mode 4	0/1	1	110 111	Conditional vertical data replacement

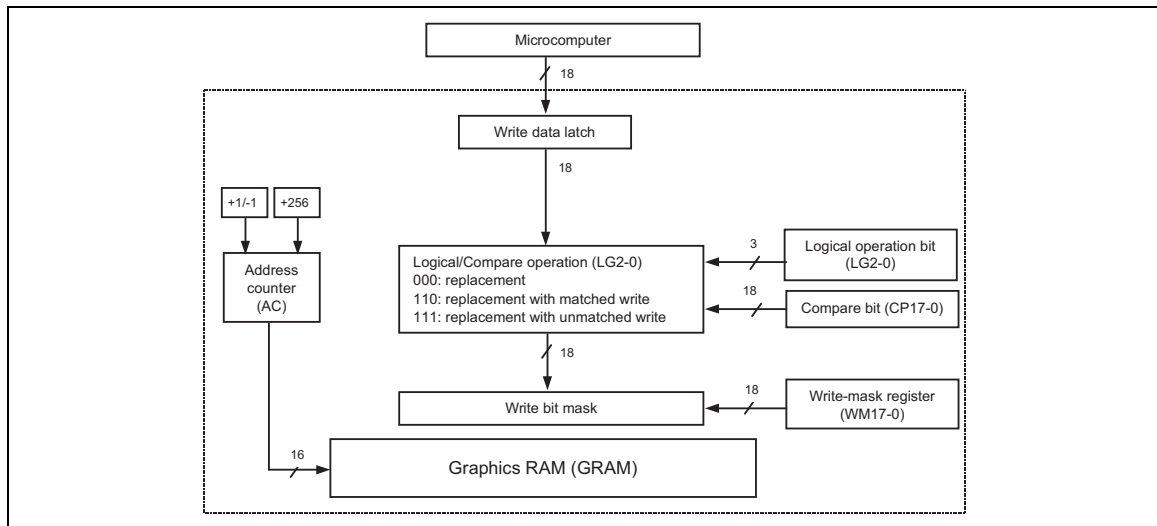

Graphics operation flow

**Write-data Mask Function**

The HD66789 expands the 16-bit data sent from the microcomputer into the 18-bit data. In the 18-bit interface mode, data are not expanded. The write data mask function of the HD66789 controls the write operation of the 18-bit data from the microcomputer to GRAM by bit. The write data mask function write data in the bits whose corresponding bits in the write data mask register (WM17-0) are assigned with "0". It does not write data in the bits whose corresponding bits in the write data mask register (WM17-0) are assigned with "1", and the corresponding data in GRAM are not overwritten but retained. This function is useful when only one-pixel data are rewritten or a particular color in the display is selectively changed.

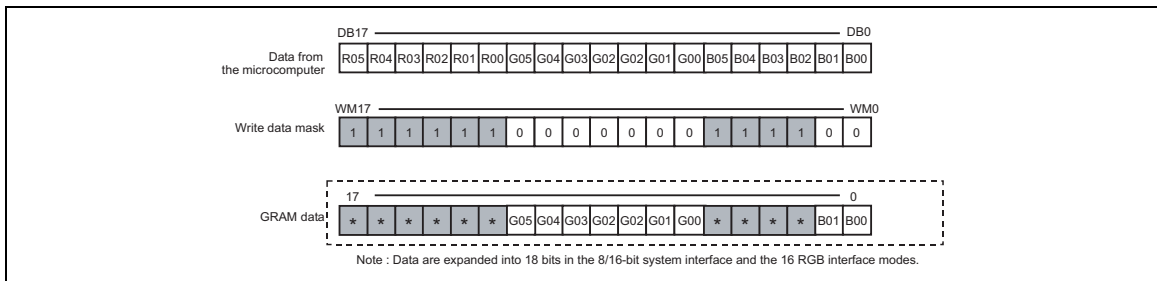

**Write data mask function**

**Graphics Operation Processing**

1. Write mode 1: AM = 0, LG2-0 = 000

This mode is used when data are horizontally written in high-speed mode. It is also used to initialize the graphics RAM (GRAM) or to draw a line horizontally. The write-data mask function (WM17-0) is also available with this mode. After writing, the address counter (AC) automatically increments by 1 (I/D = 1) or decrements by 1 (I/D = 0), and jumps to the counter at the opposing edge of the next one-raster-row below after when the counter reaches either left or right edge of GRAM.

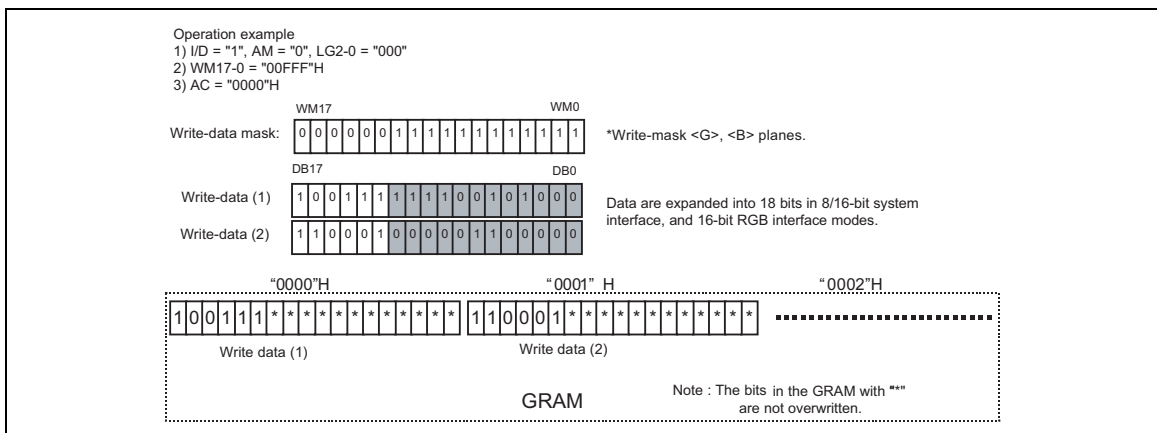

**Write Mode 1**

2. Write mode 2: AM = 1, LG2-0 = 000

This mode is used when data are vertically written in high-speed mode. It is also used to initialize the graphics RAM (GRAM), develop font patterns or draw a line vertically. The write-data mask function (WM17-0) is also available with this mode. After writing, the address counter (AC) automatically increments by 256, and automatically jumps to the counter either at the top of the next right row (ID = 1) or at the top of the next left row (ID = 0) according to the setting in the I/D bit, when the address reaches the bottom of GRAM.

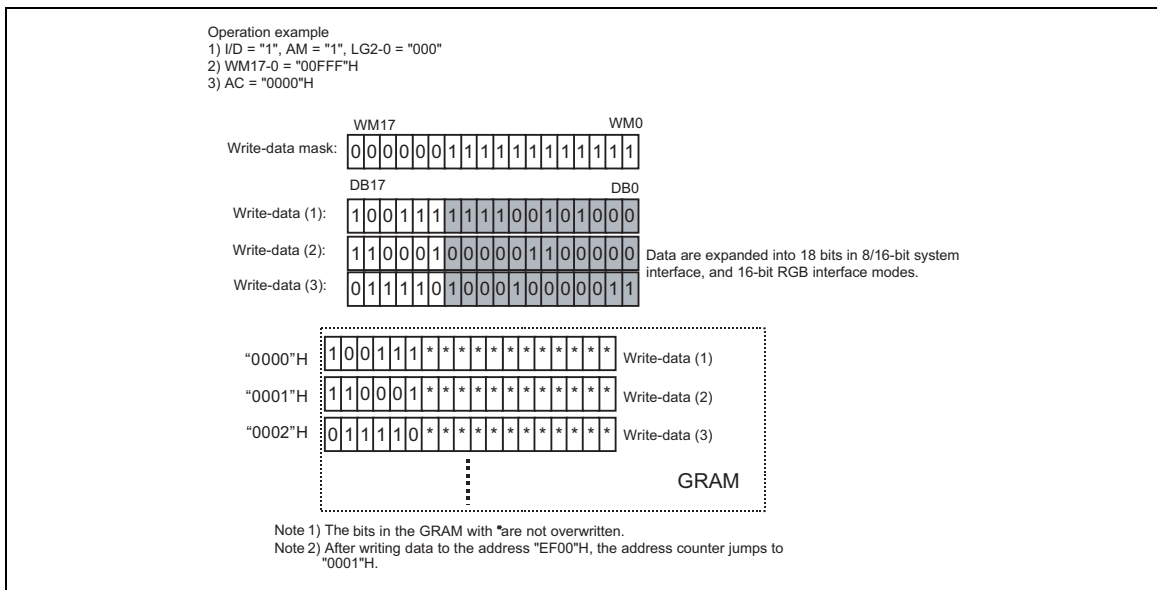

**Write Mode 2**





### γ-Correction Function

The HD66789 incorporates  $\gamma$ -correction function to simultaneously display 262,144 colors, by which 8-level grayscale is determined by the gradient-adjustment and fine-adjustment registers. Select either positive or negative polarity of the registers according to the characteristics of a liquid crystal panel.

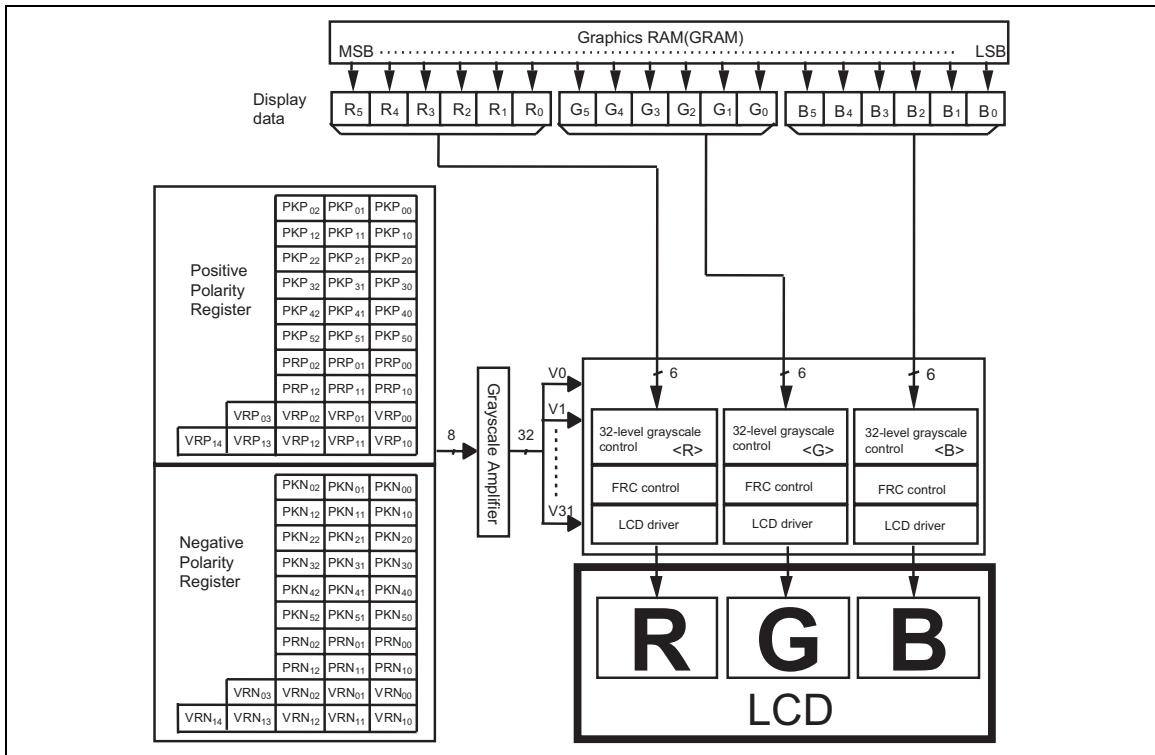

Grayscale control

**Configuration of Grayscale Amplifier**

The eight levels (VIN0-7) of grayscale are determined by the gradient adjustment and fine adjustment registers. The 8 levels are then divided into 32 levels (V0-31) by the ladder resistors placed between each level.

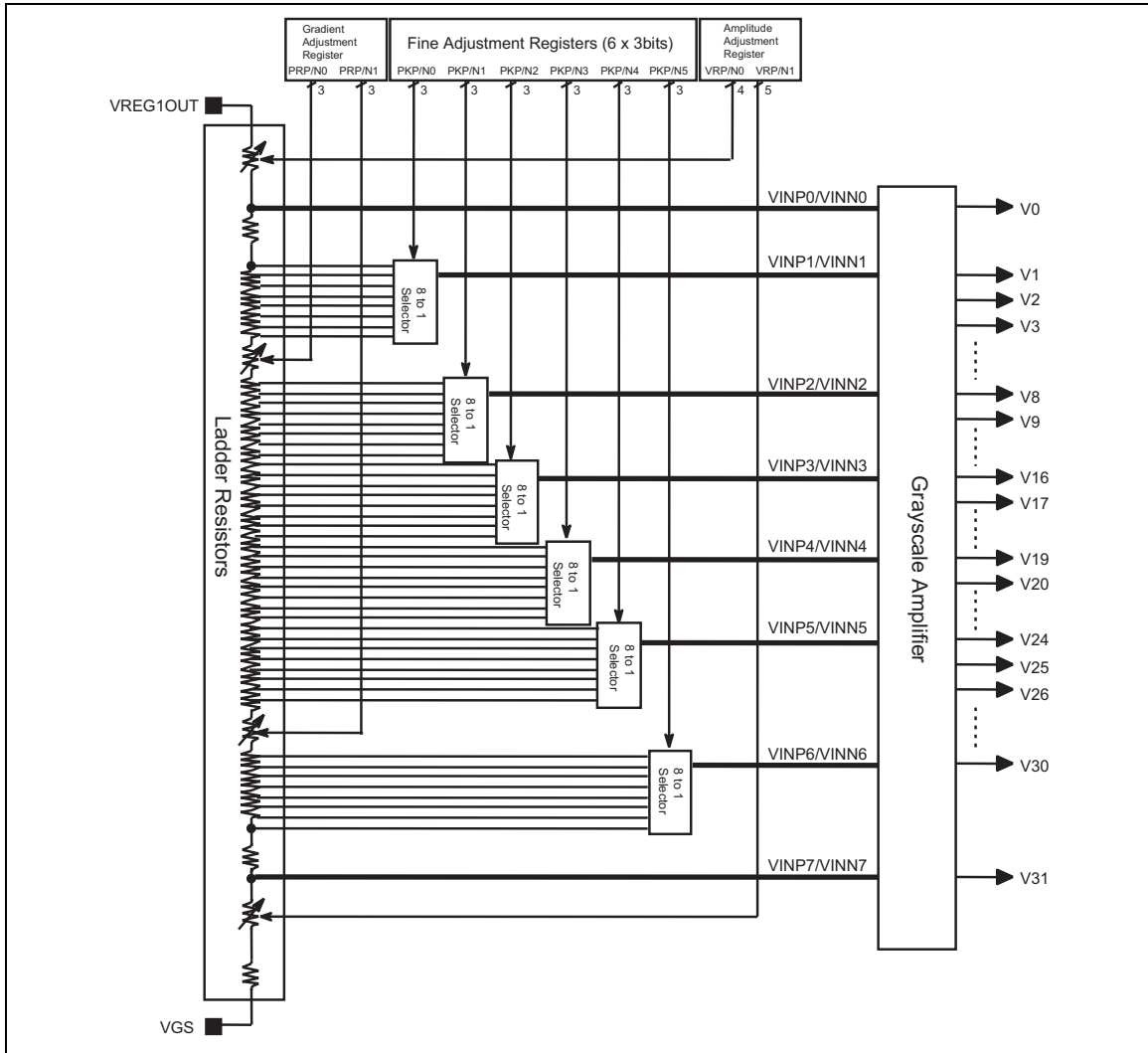

**Grayscale amplifier**



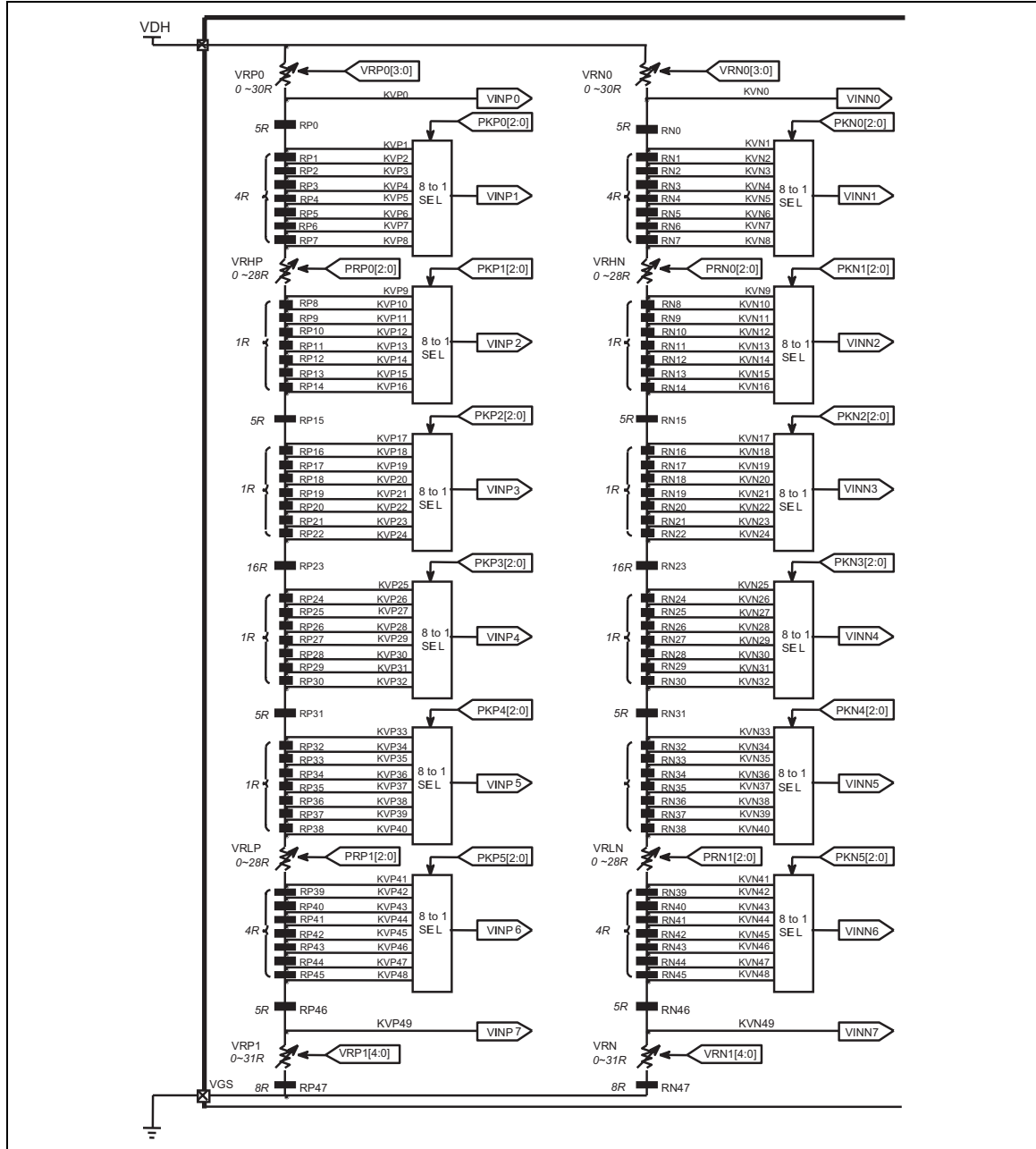

Ladder Resistors and 8-to-1 Selector

### $\gamma$ -Correction Register

The  $\gamma$ -adjustment register is a group of registers to set an appropriate grayscale voltage for the  $\gamma$ -characteristics of a liquid crystal panel. The register group is categorized into the ones adjusting gradient, amplitude, and fine-tuning in relation to grayscale number and grayscale voltage characteristics. Each register can make an independent setting for the positive/negative polarity. The reference value and RGB are common to both polarities.

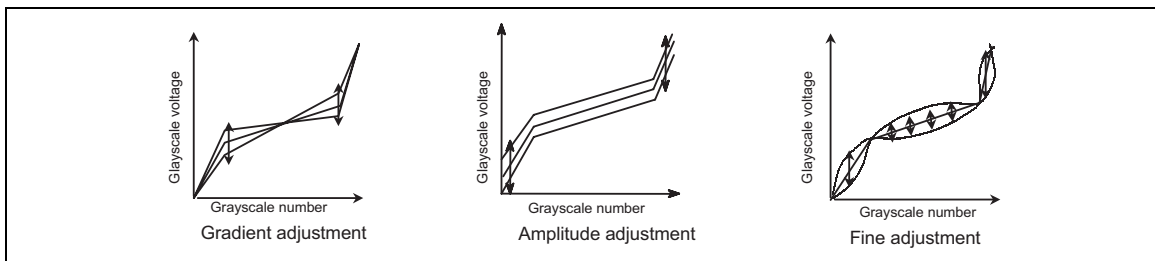

**Gradient, Amplitude, Fine Adjustments**

#### 1. Gradient adjustment registers

The gradient adjustment registers are used to adjust the gradient around the middle of the grayscale number and voltage characteristics without changing a dynamic range. To adjust a gradient, the values of the variable resistors (VRHP (N)/VRLP (N)) in the middle of the ladder resistor block for grayscale voltage generation are controlled. The registers incorporate separate registers for positive and negative polarities to be compatible with asymmetric drive.

#### 2. Amplitude adjustment registers

The amplitude adjustment registers are used to adjust the amplitude of the grayscale voltage. To adjust the amplitude, the values of the variable resistors (VRP(N)1/0) in the bottom of the ladder resistor block for grayscale voltage generation are adjusted. Same with the gradient registers, the amplitude adjustment registers also incorporate separate registers for positive and negative polarities.

#### 3. Fine adjustment registers

The fine adjustment register is to fine-adjust the grayscale voltage level. To fine-adjust the grayscale voltage level, each level of 8-level reference voltages generated from the ladder registers is controlled by 8-to-1 selector. Same with the other registers, the fine-adjustment registers also incorporate separate registers for positive and negative polarities.

**$\gamma$ -Correction Registers**

Register Groups	Positive Polarity	Negative Polarity	Description
Gradient adjustment	PRP0 2 to 0	PRN0 2 to 0	Variable resistor VRHP (N)
	PRP1 2 to 0	PRN1 2 to 0	Variable resistor VRLP (N)
Amplitude adjustment	VRP0 3 to 0	VRN0 3 to 0	Variable resistor VRP (N)0
	VRP1 4 to 0	VRN1 4 to 0	Variable resistor VRP (N)1
Fine adjustment	PKP0 2 to 0	PKN0 2 to 0	8-to-1 selector (voltage level of grayscale 1)
	PKP1 2 to 0	PKN1 2 to 0	8-to-1 selector (voltage level of grayscale 8)
	PKP2 2 to 0	PKN2 2 to 0	8-to-1 selector (voltage level of grayscale 20)
	PKP3 2 to 0	PKN3 2 to 0	8-to-1 selector (voltage level of grayscale 43)
	PKP4 2 to 0	PKN4 2 to 0	8-to-1 selector (voltage level of grayscale 55)
	PKP5 2 to 0	PKN5 2 to 0	8-to-1 selector (voltage level of grayscale 62)

**Ladder resistors and 8-to-1 selector****Block configuration**

The block diagram of page **112** consists of two ladder resistors including variable resistors, and 8-to-1 selectors which select the voltage generated by the ladder resistors to output a reference voltage for the grayscale voltage. The variable resistors and the 8-to-1 selectors are controlled by the  $\gamma$  correction registers. Pins that are connected to a variable resistor are provided to compensate the variation among the panels.

**Variable resistor**

There are three kinds of variable resistors for the gradient adjustment (VRHP(N)/VRLP(N)), the amplitude adjustment (1) (VRP(N)0), and the amplitude adjustment (2) (VRP(N)1). The resistance is determined by the gradient adjustment and amplitude adjustment registers as is shown below.

Gradient adjustment		Amplitude adjustment (1)		Amplitude adjustment (2)	
Contents of Register PRP(N) 0/1[2:0]	Resistance VRHP(N) VRLP(N)	Contents of Register VRP(N)0[3:0]	Resistance VRP(N)0	Contents of Register VRP(N)1[4:0]	Resistance VRP(N)1
000	0R	0000	0R	00000	0R
001	4R	0001	2R	00001	1R
010	8R	0010	4R	00010	2R
011	12R	⋮	⋮	⋮	⋮
100	16R	⋮	⋮	⋮	⋮
101	20R	1101	26R	11101	29R
110	24R	1111	28R	11110	30R
111	28R	1111	30R	11111	31R

**8-to-1 selector**

The 8-to-1 selectors select a voltage level generated by the ladder resistors according to the fine adjustment registers, and output six kinds of reference voltage, VIN1 to VIN 6. The relationship between the fine adjustment register and the selected voltage is as follows.

**Fine adjustment registers and selected voltage**

The value of Register PKP(N)[2:0]	Selected Voltage					
	VINP(N)1	VINP(N)2	VINP(N)3	VINP(N)4	VINP(N)5	VINP(N)6
000	KVP(N)1	KVP(N)9	KVP(N)17	KVP(N)25	KVP(N)33	KVP(N)41
001	KVP(N)2	KVP(N)10	KVP(N)18	KVP(N)26	KVP(N)34	KVP(N)42
010	KVP(N)3	KVP(N)11	KVP(N)19	KVP(N)27	KVP(N)35	KVP(N)43
011	KVP(N)4	KVP(N)12	KVP(N)20	KVP(N)28	KVP(N)36	KVP(N)44
100	KVP(N)5	KVP(N)13	KVP(N)21	KVP(N)29	KVP(N)37	KVP(N)45
101	KVP(N)6	KVP(N)14	KVP(N)22	KVP(N)30	KVP(N)38	KVP(N)46
110	KVP(N)7	KVP(N)15	KVP(N)23	KVP(N)31	KVP(N)39	KVP(N)47
111	KVP(N)8	KVP(N)16	KVP(N)24	KVP(N)32	KVP(N)40	KVP(N)48

The grayscale levels (V0-V31) are calculated according to the following formulas.

**Formulas for calculating voltage (Positive polarity) (1)**

Pin	Formula	Fine adjustment register value	Reference Voltage
KVP0	$VREG1OUT - \Delta V \cdot VRP0 / SUMRP$	-	VINP0
KVP1	$VREG1OUT - \Delta V \cdot (VRP0+5R) / SUMRP$	PKP02-00 = "000"	VINP1
KVP2	$VREG1OUT - \Delta V \cdot (VRP0+9R) / SUMRP$	PKP02-00 = "001"	
KVP3	$VREG1OUT - \Delta V \cdot (VRP0+13R) / SUMRP$	PKP02-00 = "010"	
KVP4	$VREG1OUT - \Delta V \cdot (VRP0+17R) / SUMRP$	PKP02-00 = "011"	
KVP5	$VREG1OUT - \Delta V \cdot (VRP0+21R) / SUMRP$	PKP02-00 = "100"	
KVP6	$VREG1OUT - \Delta V \cdot (VRP0+25R) / SUMRP$	PKP02-00 = "101"	
KVP7	$VREG1OUT - \Delta V \cdot (VRP0+29R) / SUMRP$	PKP02-00 = "110"	
KVP8	$VREG1OUT - \Delta V \cdot (VRP0+33R) / SUMRP$	PKP02-00 = "111"	VINP2
KVP9	$VREG1OUT - \Delta V \cdot (VRP0+33R+VRHP) / SUMRP$	PKP12-10 = "000"	
KVP10	$VREG1OUT - \Delta V \cdot (VRP0+34R+VRHP) / SUMRP$	PKP12-10 = "001"	
KVP11	$VREG1OUT - \Delta V \cdot (VRP0+35R+VRHP) / SUMRP$	PKP12-10 = "010"	
KVP12	$VREG1OUT - \Delta V \cdot (VRP0+36R+VRHP) / SUMRP$	PKP12-10 = "011"	
KVP13	$VREG1OUT - \Delta V \cdot (VRP0+37R+VRHP) / SUMRP$	PKP12-10 = "100"	
KVP14	$VREG1OUT - \Delta V \cdot (VRP0+38R+VRHP) / SUMRP$	PKP12-10 = "101"	
KVP15	$VREG1OUT - \Delta V \cdot (VRP0+39R+VRHP) / SUMRP$	PKP12-10 = "110"	VINP3
KVP16	$VREG1OUT - \Delta V \cdot (VRP0+40R+VRHP) / SUMRP$	PKP12-10 = "111"	
KVP17	$VREG1OUT - \Delta V \cdot (VRP0+45R+VRHP) / SUMRP$	PKP22-20 = "000"	
KVP18	$VREG1OUT - \Delta V \cdot (VRP0+46R+VRHP) / SUMRP$	PKP22-20 = "001"	
KVP19	$VREG1OUT - \Delta V \cdot (VRP0+47R+VRHP) / SUMRP$	PKP22-20 = "010"	
KVP20	$VREG1OUT - \Delta V \cdot (VRP0+48R+VRHP) / SUMRP$	PKP22-20 = "011"	
KVP21	$VREG1OUT - \Delta V \cdot (VRP0+49R+VRHP) / SUMRP$	PKP22-20 = "100"	
KVP22	$VREG1OUT - \Delta V \cdot (VRP0+50R+VRHP) / SUMRP$	PKP22-20 = "101"	VINP4
KVP23	$VREG1OUT - \Delta V \cdot (VRP0+51R+VRHP) / SUMRP$	PKP22-20 = "110"	
KVP24	$VREG1OUT - \Delta V \cdot (VRP0+52R+VRHP) / SUMRP$	PKP22-20 = "111"	
KVP25	$VREG1OUT - \Delta V \cdot (VRP0+68R+VRHP) / SUMRP$	PKP32-30 = "000"	
KVP26	$VREG1OUT - \Delta V \cdot (VRP0+69R+VRHP) / SUMRP$	PKP32-30 = "001"	
KVP27	$VREG1OUT - \Delta V \cdot (VRP0+70R+VRHP) / SUMRP$	PKP32-30 = "010"	
KVP28	$VREG1OUT - \Delta V \cdot (VRP0+71R+VRHP) / SUMRP$	PKP32-30 = "011"	
KVP29	$VREG1OUT - \Delta V \cdot (VRP0+72R+VRHP) / SUMRP$	PKP32-30 = "100"	VINP5
KVP30	$VREG1OUT - \Delta V \cdot (VRP0+73R+VRHP) / SUMRP$	PKP32-30 = "101"	
KVP31	$VREG1OUT - \Delta V \cdot (VRP0+74R+VRHP) / SUMRP$	PKP32-30 = "110"	
KVP32	$VREG1OUT - \Delta V \cdot (VRP0+75R+VRHP) / SUMRP$	PKP32-30 = "111"	
KVP33	$VREG1OUT - \Delta V \cdot (VRP0+80R+VRHP) / SUMRP$	PKP42-40 = "000"	
KVP34	$VREG1OUT - \Delta V \cdot (VRP0+81R+VRHP) / SUMRP$	PKP42-40 = "001"	
KVP35	$VREG1OUT - \Delta V \cdot (VRP0+82R+VRHP) / SUMRP$	PKP42-40 = "010"	
KVP36	$VREG1OUT - \Delta V \cdot (VRP0+83R+VRHP) / SUMRP$	PKP42-40 = "011"	VINP6
KVP37	$VREG1OUT - \Delta V \cdot (VRP0+84R+VRHP) / SUMRP$	PKP42-40 = "100"	
KVP38	$VREG1OUT - \Delta V \cdot (VRP0+85R+VRHP) / SUMRP$	PKP42-40 = "101"	
KVP39	$VREG1OUT - \Delta V \cdot (VRP0+86R+VRHP) / SUMRP$	PKP42-40 = "110"	
KVP40	$VREG1OUT - \Delta V \cdot (VRP0+87R+VRHP) / SUMRP$	PKP42-40 = "111"	
KVP41	$VREG1OUT - \Delta V \cdot (VRP0+87R+VRHP+VRLP) / SUMRP$	PKP52-50 = "000"	
KVP42	$VREG1OUT - \Delta V \cdot (VRP0+91R+VRHP+VRLP) / SUMRP$	PKP52-50 = "001"	
KVP43	$VREG1OUT - \Delta V \cdot (VRP0+95R+VRHP+VRLP) / SUMRP$	PKP52-50 = "010"	VINP7
KVP44	$VREG1OUT - \Delta V \cdot (VRP0+99R+VRHP+VRLP) / SUMRP$	PKP52-50 = "011"	
KVP45	$VREG1OUT - \Delta V \cdot (VRP0+103R+VRHP+VRLP) / SUMRP$	PKP52-50 = "100"	
KVP46	$VREG1OUT - \Delta V \cdot (VRP0+107R+VRHP+VRLP) / SUMRP$	PKP52-50 = "101"	
KVP47	$VREG1OUT - \Delta V \cdot (VRP0+111R+VRHP+VRLP) / SUMRP$	PKP52-50 = "110"	
KVP48	$VREG1OUT - \Delta V \cdot (VRP0+115R+VRHP+VRLP) / SUMRP$	PKP52-50 = "111"	
KVP49	$VREG1OUT - \Delta V \cdot (VRP0+120R+VRHP+VRLP) / SUMRP$	-	

SUMRP : Sum of positive ladder resistors = 128R+VRHP+VRLP+VRP0+VRP1  
SUMRN : Sum of negative ladder resistors = 128R+VRHN+VRLN+VRN0+VRN1  
ΔV : Voltage difference between VREG1OUT and VGS

**Formulas for calculating voltage (Positive polarity) (2)**

Grayscale Voltage	Formula
V0	VINP0
V1	$V4+(VINP1-V4)*(15/24)$
V2	$V4+(VINP1-V4)*(8/24)$
V3	$V4+(VINP1-V4)*(4/24)$
V4	VINP2
V5	$V10+(V4-V10)*(20/24)$
V6	$V10+(V4-V10)*(16/24)$
V7	$V10+(V4-V10)*(12/24)$
V8	$V10+(V4-V10)*(8/24)$
V9	$V20+(V8-V20)*(4/24)$
V10	VINP3
V11	$V21+(V10-V21)*(21/24)$
V12	$V21+(V10-V21)*(19/24)$
V13	$V21+(V10-V21)*(17/24)$
V14	$V21+(V10-V21)*(15/24)$
V15	$V21+(V10-V21)*(13/24)$
V16	$V21+(V10-V21)*(11/24)$
V17	$V21+(V10-V21)*(9/24)$
V18	$V21+(V10-V21)*(7/24)$
V19	$V21+(V10-V21)*(5/24)$
V20	$V21+(V10-V21)*(3/24)$
V21	VINP4
V22	$V27+(V21-V27)*(20/24)$
V23	$V27+(V21-V27)*(16/24)$
V24	$V27+(V21-V27)*(12/24)$
V25	$V27+(V21-V27)*(8/24)$
V26	$V27+(V21-V27)*(4/24)$
V27	VINP5
V28	$VINP6+(V27-VINP6)*(20/24)$
V29	$VINP6+(V27-VINP6)*(16/24)$
V30	$VINP6+(V27-VINP6)*(9/24)$
V31	VINP7

Note : Make sure DDVDH - V0 > 0.5V  
DDVDH - V4 > 1.1V

Formulas for calculating voltage (Negative polarity) (1)

Pin	Formula	Fine adjustment register value	Reference Voltage
KVP0	$VREG1OUT - \Delta V \cdot VRN0 / SUMRN$	-	VINN0
KVN1	$VREG1OUT - \Delta V \cdot (VRN0 + 5R) / SUMRN$	PKN 02-00 = "000"	VINN1
KVN2	$VREG1OUT - \Delta V \cdot (VRN0 + 9R) / SUMRN$	PKN 02-00 = "001"	
KVN3	$VREG1OUT - \Delta V \cdot (VRN0 + 13R) / SUMRN$	PKN 02-00 = "010"	
KVN4	$VREG1OUT - \Delta V \cdot (VRN0 + 17R) / SUMRN$	PKN 02-00 = "011"	
KVN5	$VREG1OUT - \Delta V \cdot (VRN0 + 21R) / SUMRN$	PKN 02-00 = "100"	
KVN6	$VREG1OUT - \Delta V \cdot (VRN0 + 25R) / SUMRN$	PKN 02-00 = "101"	
KVN7	$VREG1OUT - \Delta V \cdot (VRN0 + 29R) / SUMRN$	PKN 02-00 = "110"	
KVN8	$VREG1OUT - \Delta V \cdot (VRN0 + 33R) / SUMRN$	PKN 02-00 = "111"	
KVN9	$VREG1OUT - \Delta V \cdot (VRN0 + 33R + VRHN) / SUMRN$	PKN 12-10 = "000"	VINN2
KVN10	$VREG1OUT - \Delta V \cdot (VRN0 + 34R + VRHN) / SUMRN$	PKN 12-10 = "001"	
KVN11	$VREG1OUT - \Delta V \cdot (VRN0 + 35R + VRHN) / SUMRN$	PKN 12-10 = "010"	
KVN12	$VREG1OUT - \Delta V \cdot (VRN0 + 36R + VRHN) / SUMRN$	PKN 12-10 = "011"	
KVN13	$VREG1OUT - \Delta V \cdot (VRN0 + 37R + VRHN) / SUMRN$	PKN 12-10 = "100"	
KVN14	$VREG1OUT - \Delta V \cdot (VRN0 + 38R + VRHN) / SUMRN$	PKN 12-10 = "101"	
KVN15	$VREG1OUT - \Delta V \cdot (VRN0 + 39R + VRHN) / SUMRN$	PKN 12-10 = "110"	
KVN16	$VREG1OUT - \Delta V \cdot (VRN0 + 40R + VRHN) / SUMRN$	PKN 12-10 = "111"	
KVN17	$VREG1OUT - \Delta V \cdot (VRN0 + 45R + VRHN) / SUMRN$	PKN 22-20 = "000"	VINN3
KVN18	$VREG1OUT - \Delta V \cdot (VRN0 + 46R + VRHN) / SUMRN$	PKN 22-20 = "001"	
KVN19	$VREG1OUT - \Delta V \cdot (VRN0 + 47R + VRHN) / SUMRN$	PKN 22-20 = "010"	
KVN20	$VREG1OUT - \Delta V \cdot (VRN0 + 48R + VRHN) / SUMRN$	PKN 22-20 = "011"	
KVN21	$VREG1OUT - \Delta V \cdot (VRN0 + 49R + VRHN) / SUMRN$	PKN 22-20 = "100"	
KVN22	$VREG1OUT - \Delta V \cdot (VRN0 + 50R + VRHN) / SUMRN$	PKN 22-20 = "101"	
KVN23	$VREG1OUT - \Delta V \cdot (VRN0 + 51R + VRHN) / SUMRN$	PKN 22-20 = "110"	
KVN24	$VREG1OUT - \Delta V \cdot (VRN0 + 52R + VRHN) / SUMRN$	PKN 22-20 = "111"	
KVN25	$VREG1OUT - \Delta V \cdot (VRN0 + 68R + VRHN) / SUMRN$	PKN 32-30 = "000"	VINN4
KVN26	$VREG1OUT - \Delta V \cdot (VRN0 + 69R + VRHN) / SUMRN$	PKN 32-30 = "001"	
KVN27	$VREG1OUT - \Delta V \cdot (VRN0 + 70R + VRHN) / SUMRN$	PKN 32-30 = "010"	
KVN28	$VREG1OUT - \Delta V \cdot (VRN0 + 71R + VRHN) / SUMRN$	PKN 32-30 = "011"	
KVN29	$VREG1OUT - \Delta V \cdot (VRN0 + 72R + VRHN) / SUMRN$	PKN 32-30 = "100"	
KVN30	$VREG1OUT - \Delta V \cdot (VRN0 + 73R + VRHN) / SUMRN$	PKN 32-30 = "101"	
KVN31	$VREG1OUT - \Delta V \cdot (VRN0 + 74R + VRHN) / SUMRN$	PKN 32-30 = "110"	
KVN32	$VREG1OUT - \Delta V \cdot (VRN0 + 75R + VRHN) / SUMRN$	PKN 32-30 = "111"	
KVN33	$VREG1OUT - \Delta V \cdot (VRN0 + 80R + VRHN) / SUMRN$	PKN 42-40 = "000"	VINN5
KVN34	$VREG1OUT - \Delta V \cdot (VRN0 + 81R + VRHN) / SUMRN$	PKN 42-40 = "001"	
KVN35	$VREG1OUT - \Delta V \cdot (VRN0 + 82R + VRHN) / SUMRN$	PKN 42-40 = "010"	
KVN36	$VREG1OUT - \Delta V \cdot (VRN0 + 83R + VRHN) / SUMRN$	PKN 42-40 = "011"	
KVN37	$VREG1OUT - \Delta V \cdot (VRN0 + 84R + VRHN) / SUMRN$	PKN 42-40 = "100"	
KVN38	$VREG1OUT - \Delta V \cdot (VRN0 + 85R + VRHN) / SUMRN$	PKN 42-40 = "101"	
KVN39	$VREG1OUT - \Delta V \cdot (VRN0 + 86R + VRHN) / SUMRN$	PKN 42-40 = "110"	
KVN40	$VREG1OUT - \Delta V \cdot (VRN0 + 87R + VRHN) / SUMRN$	PKN 42-40 = "111"	
KVN41	$VREG1OUT - \Delta V \cdot (VRN0 + 87R + VRHN + VRLP) / SUMRN$	PKN 52-50 = "000"	VINN6
KVN42	$VREG1OUT - \Delta V \cdot (VRN0 + 91R + VRHN + VRLP) / SUMRN$	PKN 52-50 = "001"	
KVN43	$VREG1OUT - \Delta V \cdot (VRN0 + 95R + VRHN + VRLP) / SUMRN$	PKN 52-50 = "010"	
KVN44	$VREG1OUT - \Delta V \cdot (VRN0 + 99R + VRHN + VRLP) / SUMRN$	PKN 52-50 = "011"	
KVN45	$VREG1OUT - \Delta V \cdot (VRN0 + 103R + VRHN + VRLP) / SUMRN$	PKN 52-50 = "100"	
KVN46	$VREG1OUT - \Delta V \cdot (VRN0 + 107R + VRHN + VRLP) / SUMRN$	PKN 52-50 = "101"	
KVN47	$VREG1OUT - \Delta V \cdot (VRN0 + 111R + VRHN + VRLP) / SUMRN$	PKN 52-50 = "110"	
KVN48	$VREG1OUT - \Delta V \cdot (VRN0 + 115R + VRHN + VRLP) / SUMRN$	PKN 52-50 = "111"	
KVN49	$VREG1OUT - \Delta V \cdot (VRN0 + 120R + VRHN + VRLP) / SUMRN$	-	VINN7

SUMRP : Sum of positive ladder resistors = 128R+VRHP+VRLP+VRP0+VRP1  
SUMRN : Sum of negative ladder resistors = 128R+VRHN+VRLN+VRN0+VRN1  
ΔV: Voltage difference between VREG1OUT and VGS

**Formulas for calculating voltage (Negative polarity) (2)**

Grayscale Voltage	Formula
V0	VINN0
V1	$V4+(VINN1-V4)*(15/24)$
V2	$V4+(VINN1-V4)*(8/24)$
V3	$V4+(VINN1-V4)*(4/24)$
V4	VINN2
V5	$V10+(V4-V10)*(20/24)$
V6	$V10+(V4-V10)*(16/24)$
V7	$V10+(V4-V10)*(12/24)$
V8	$V10+(V4-V10)*(8/24)$
V9	$V20+(V8-V20)*(4/24)$
V10	VINN3
V11	$V21+(V10-V21)*(21/24)$
V12	$V21+(V10-V21)*(19/24)$
V13	$V21+(V10-V21)*(17/24)$
V14	$V21+(V10-V21)*(15/24)$
V15	$V21+(V10-V21)*(13/24)$
V16	$V21+(V10-V21)*(11/24)$
V17	$V21+(V10-V21)*(9/24)$
V18	$V21+(V10-V21)*(7/24)$
V19	$V21+(V10-V21)*(5/24)$
V20	$V21+(V10-V21)*(3/24)$
V21	VINN4
V22	$V27+(V21-V27)*(20/24)$
V23	$V27+(V21-V27)*(16/24)$
V24	$V27+(V21-V27)*(12/24)$
V25	$V27+(V21-V27)*(8/24)$
V26	$V27+(V21-V27)*(4/24)$
V27	VINN5
V28	$VINN6+(V27-VINN6)*(20/24)$
V29	$VINN6+(V27-VINN6)*(16/24)$
V30	$VINN6+(V27-VINN6)*(9/24)$
V31	VINN7

Note : Make sure DDVDH - V0 > 0.5V  
DDVDH - V4 > 1.1V



**Relationship between RAM data and output level**

The relationship between the RAM data and the source output level is as follows.

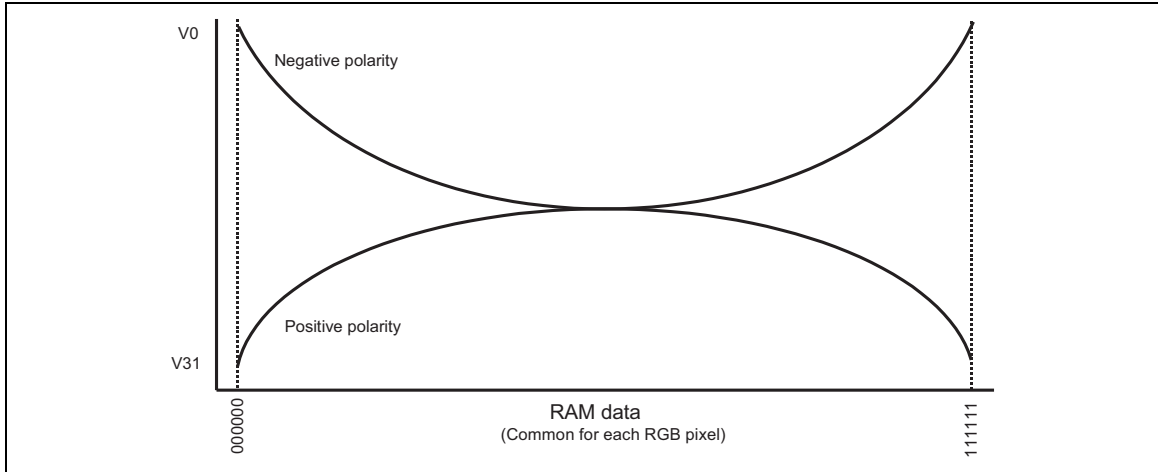

**RAM data and the output voltage**

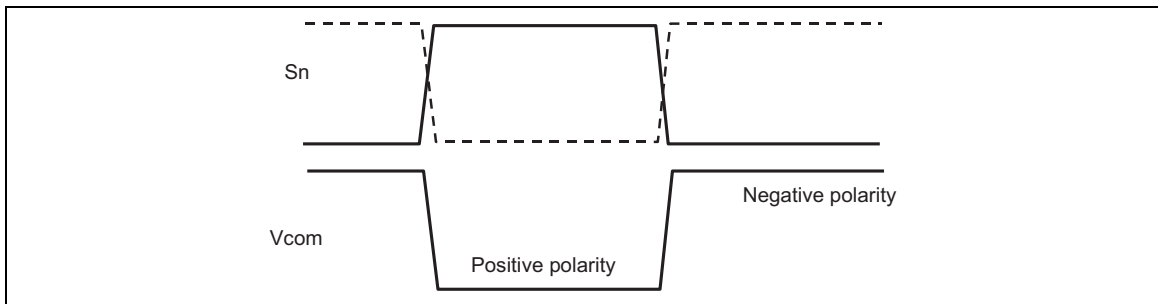

**Source output and  $V_{com}$**

### 8-color Display Mode

The HD66789 incorporates 8-color display mode. The available grayscale levels are V0 and V31, and the voltages for the other levels (V1-V30) are halted to reduce power consumption.

The  $\gamma$ -fine-adjustment registers, PKP0-PKP5 and PKN0-PKN5 are not available in the 8-color display mode. Since the power supply for the levels V1-V30 are halted, RGB data in GRAM should be set to either "000000" or "111111" before setting this mode so that V0 or V31 is selected.

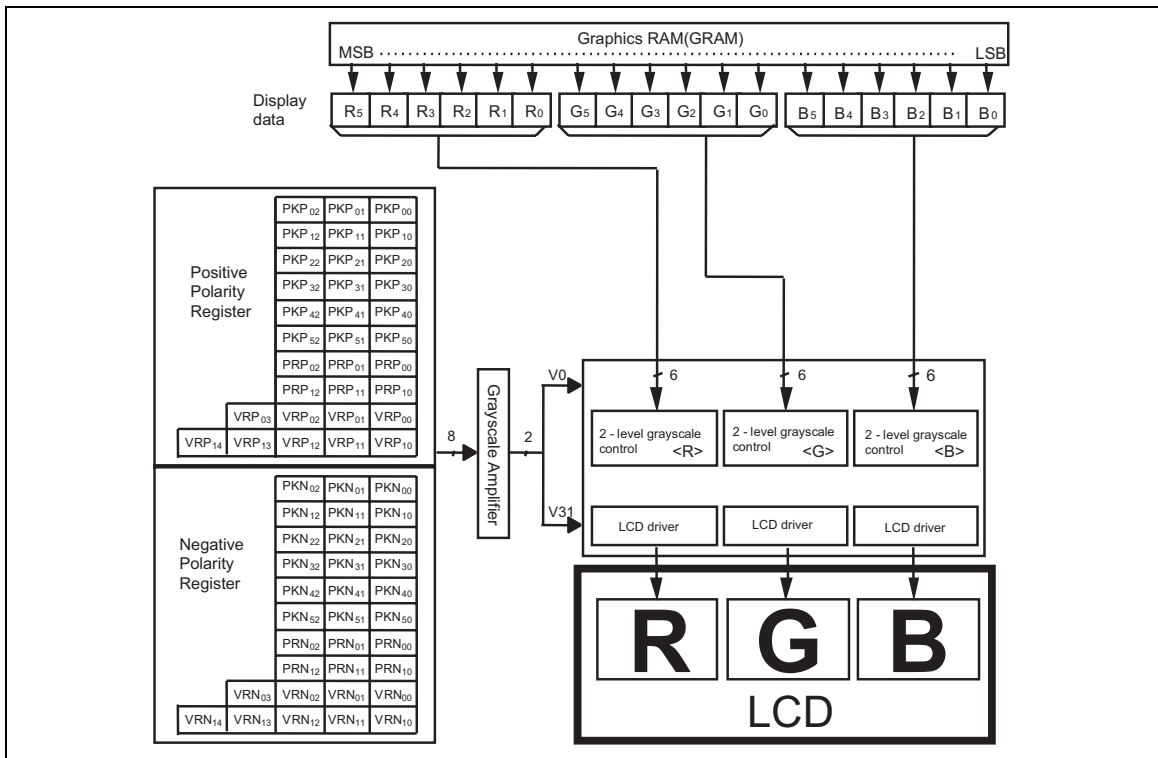

Grayscale control

To switch between the 262, 144-color mode and the 8-color mode, make settings according to the following sequences.

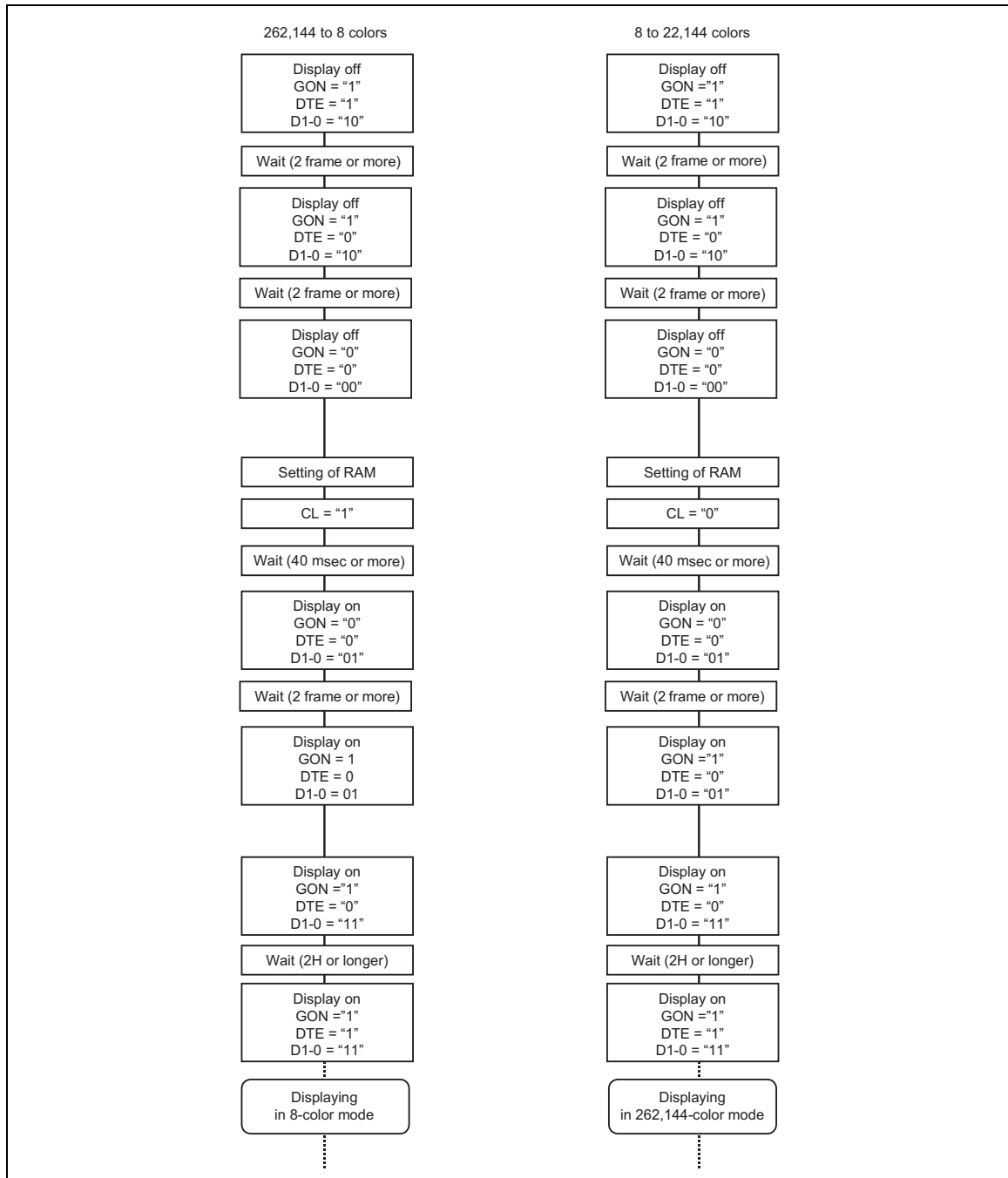

### System Configuration

The following figure illustrates an example of configuring a TFT-LCD panel of 176x 240 dots with HD66789.

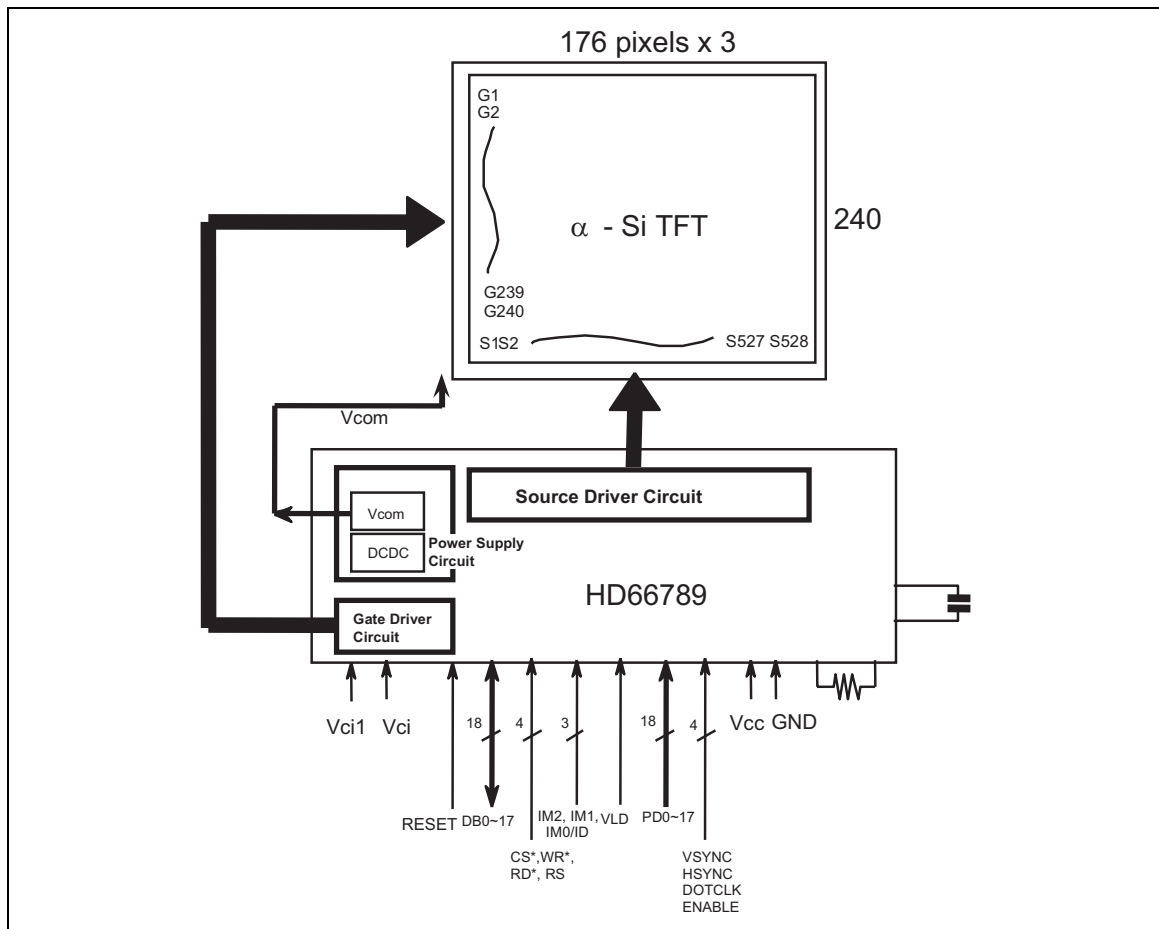

System configuration with HD66789

### Configuration of Power Generation Circuit

The internal configuration of power generation circuit of HD66789 is as follows.

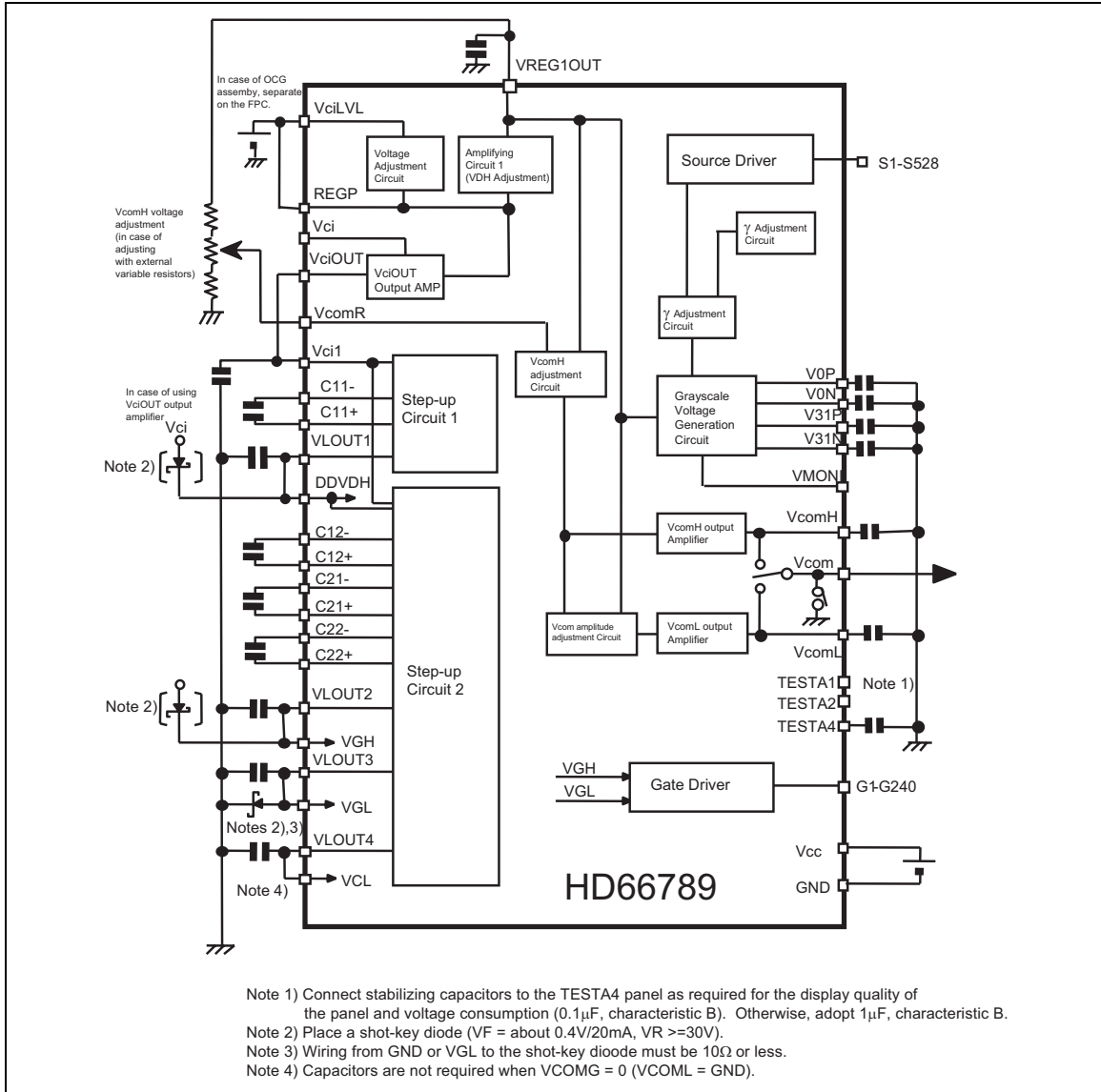

### Specification of External Elements Connected to HD66789 Power Supply

The following table shows specifications of external elements connected to HD66789 power supply.

#### Capacitor

Capacity	Recommended voltage	Connect pins
1 $\mu$ F (B characteristic)	6V	VREG1OUT, VciOUT, VOUT4, VcomH, VcomL, C11+/-, C21+/-
	10V	VLOUT1, C21+/-, C22+/-
	25V	VLOUT2, VLOUT3
0.1 $\mu$ F (B characteristic)	6V	V0P, V0N, V31P, V31N, TESTA4

#### Shot-key diode

Feature	Connect pin
$V_F < 0.4V / 20mA$ at 25 centigrade, $V_R \geq 30V$ (recommended diode : HSC226)	GND – VGL (Vci – VGH) (Vci – DDVDH)

#### Variable resistor

Feature	Connect pin
$> 200 k\Omega$	VcomR

### Instruction Setting Flow

Make a setting for each instruction according to the following sequence.

#### Display ON/OFF

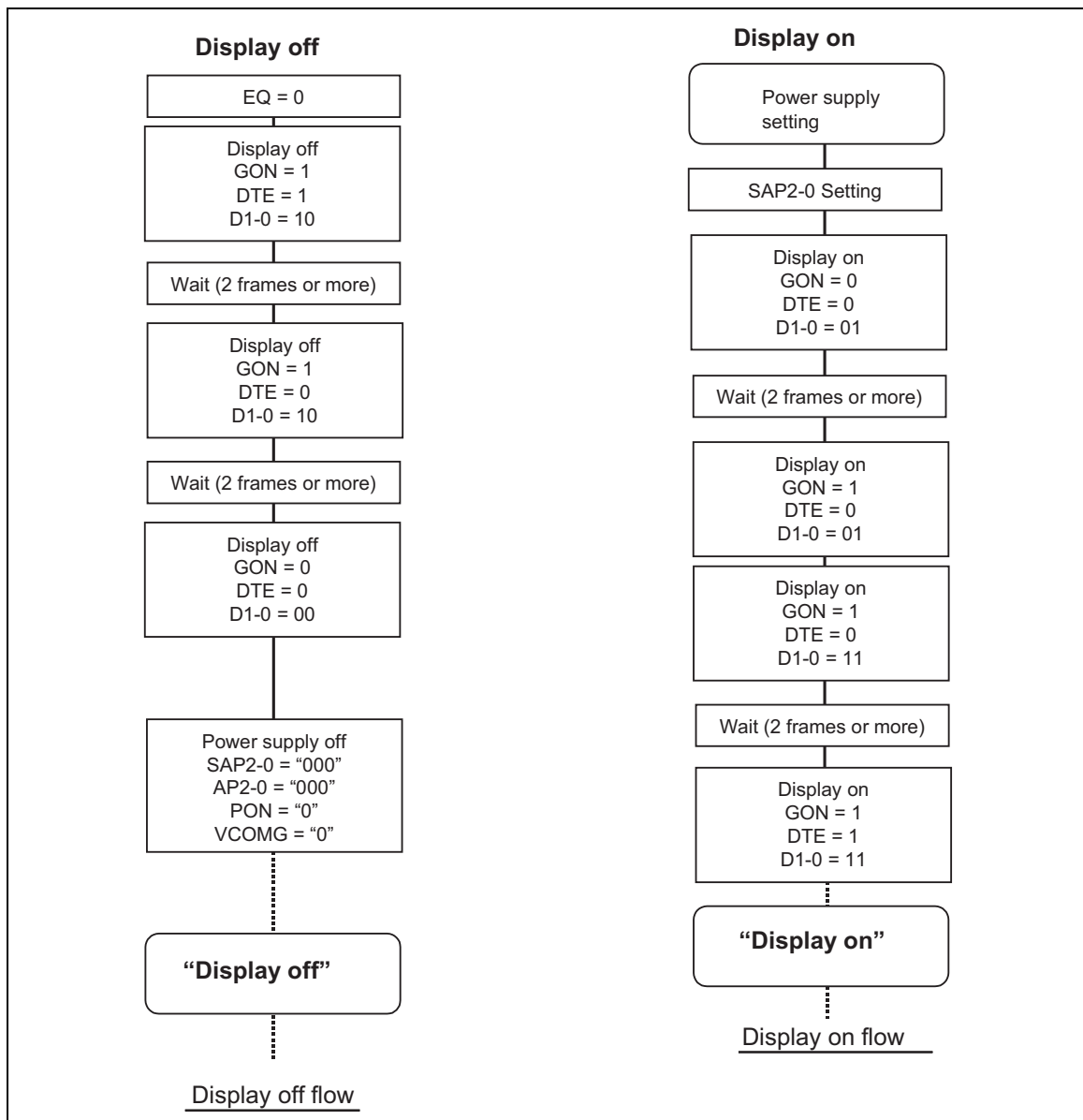

Standby and Sleep

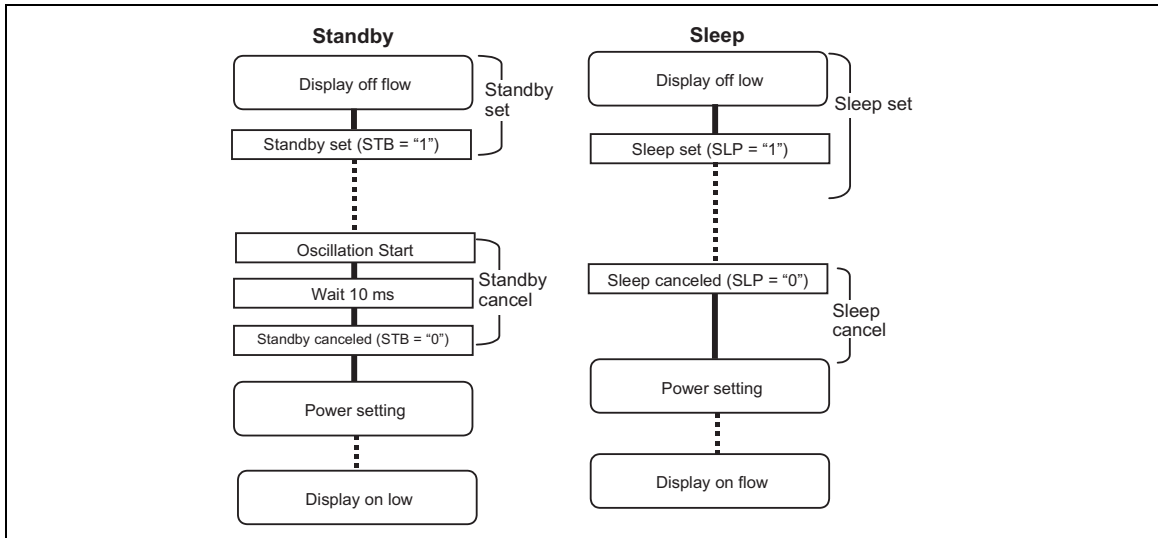



### Power Supply Setting

Whenever turning on the power supply, it must be done in accordance to the following procedure.

The stabilization time for the oscillation circuits, step-up circuits, and operational amplifiers depends on the external resistors and capacitors.

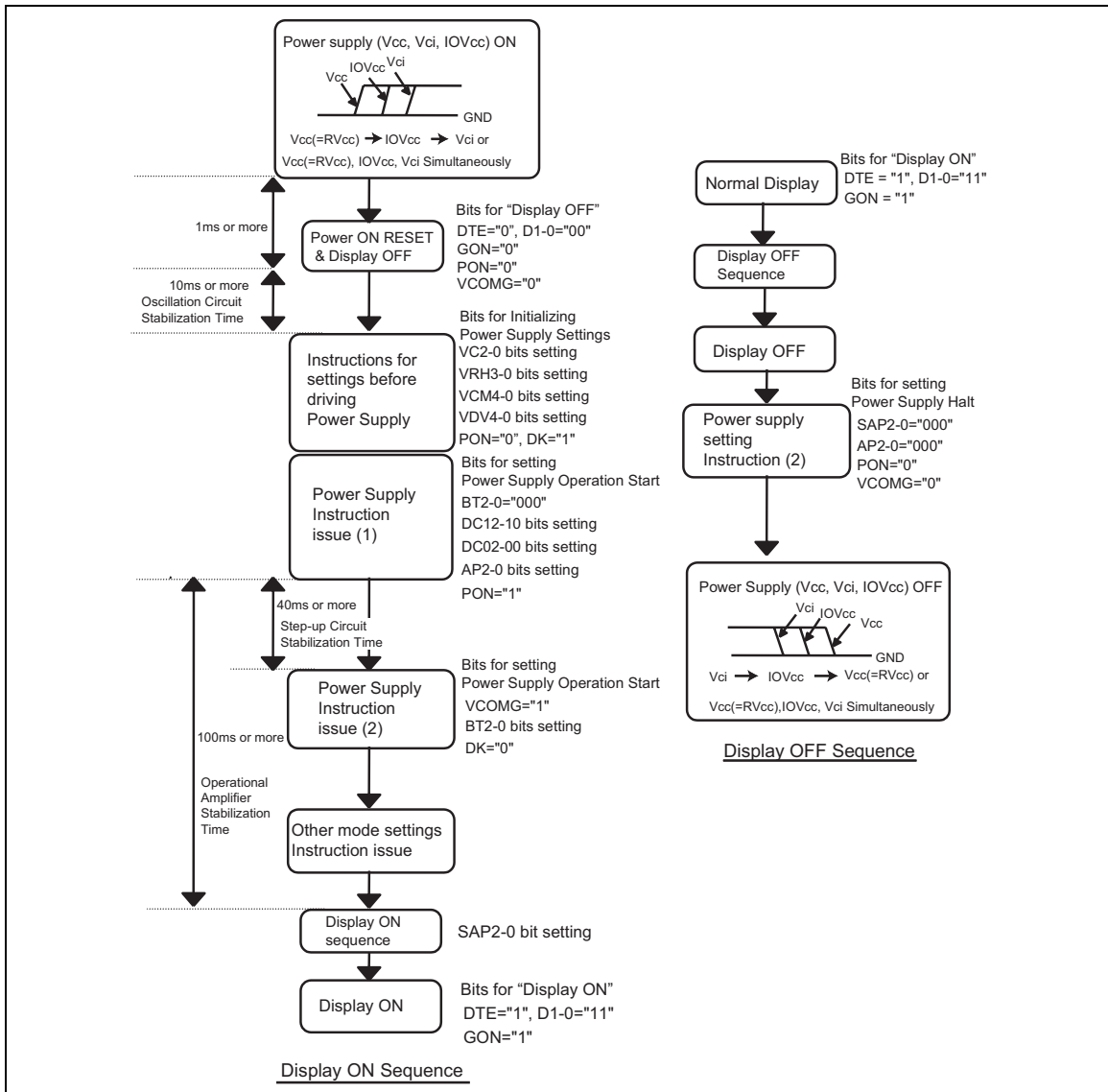

**Pattern Diagram for Voltage Setting**

The following figures are the pattern diagram of voltage setting for the HD66789 and the voltage waveforms.

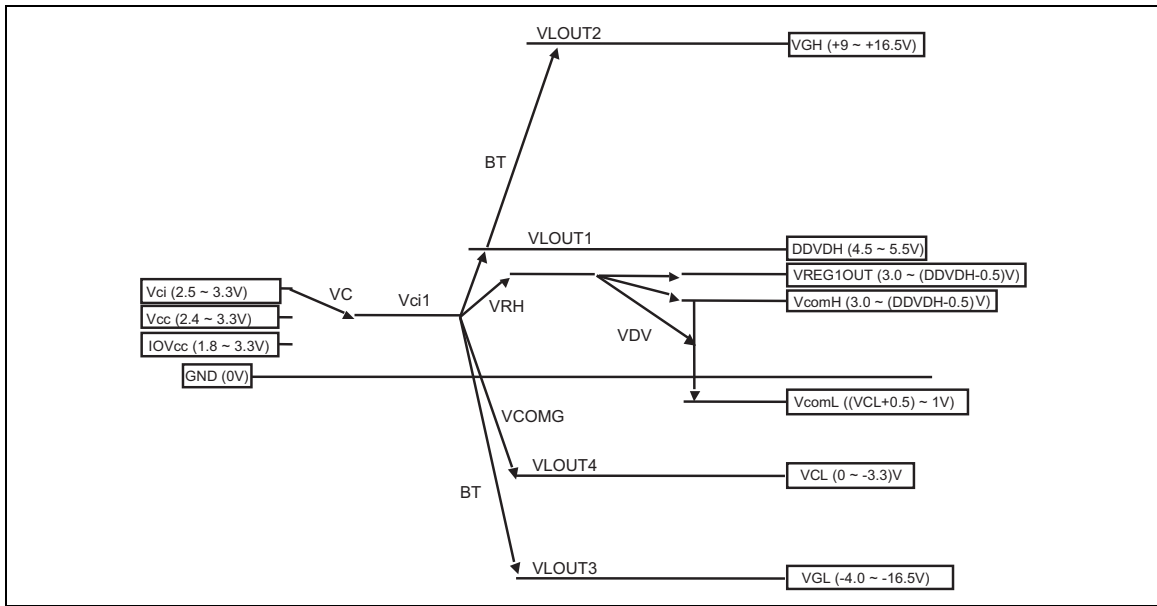

**Pattern diagram for voltage setting**

Note 1) Voltage drop occurs in relation to set voltage for each DDVDH, VGH, VGL, VCL output depending on current consumption required for each output.  $(DDVDH + VREG1OUT) > 0.5V$  and  $(VcomL - VCL) > 0.5V$  show the relationship in relation to the actual voltage. When AC frequency of Vcom1 and Vcom 2 is high (e.g. AC occurs by line), current consumption is also large. In this case, check voltage before use.

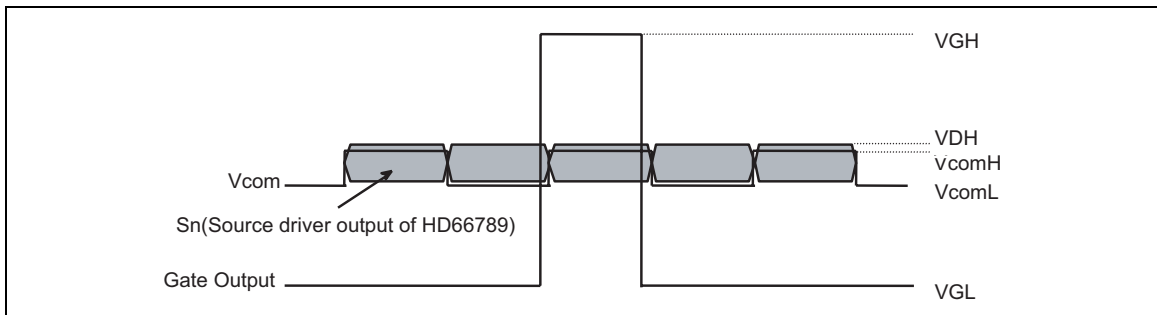

**Applied voltage to the TFT display**

## Oscillation Circuit

The HD66789 generates oscillation by internal R-C oscillator with an external oscillation resistor placed between the OSC1 and OSC2 pins. The oscillation frequency varies depending on the value of external resistor, the distance of wiring, and the power supply voltage for the oscillation. For example, the oscillation frequency becomes low when increasing the value of  $R_f$  resistor, or lowering the power supply voltage. See the “Electric Characteristics Notes” section for the relationship between the  $R_f$  resistor value and the oscillation frequency.

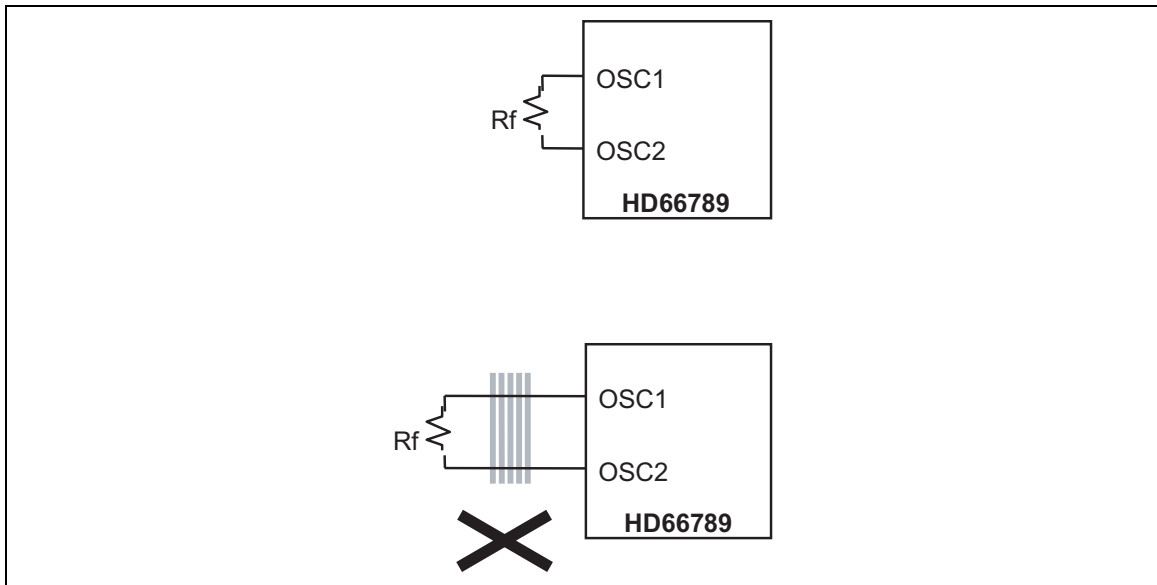

### External Resistor Oscillation Mode

Note 1) Place the  $R_f$  resistor as close as to the OSC1, OSC2 pins.

Note 2) Make sure not to arrange other wiring beneath or close to OSC1-OSC2 wiring to avoid effects from coupling.

**n-raster-row Inversion AC Drive**

The HD66789, in addition to LCD inversion AC drive by frame, supports n-raster-row inversion AC drive where alternation occurs by n raster-rows, where n takes a number between 1 to 64. The n-raster-row inversion AC drive enables to overcome the problems related to display quality.

In determining n (the value set in the NW bit +1), the number of raster-rows by which alternation occurs, check the display quality on the actual liquid crystal panel. Setting a small number of raster-rows will raise the AC frequency of the liquid crystal and increase the charge/discharge current on the liquid crystal cells..

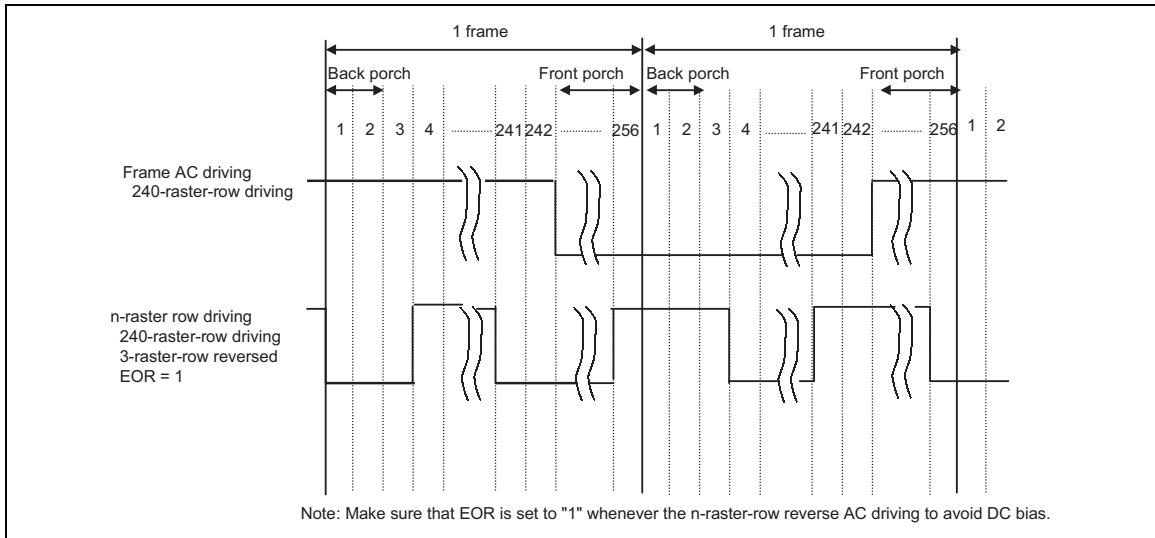

**n-raster-rows inversion AC drive**

### Interlaced Drive

The HD66789 supports interlaced drive, which divides one frame into n fields and then drives to prevent flickers.

To determine the number of fields (n: value set in the FLD bits), check the display quality on the actual liquid crystal panel. The following table shows the gate selection for each number of fields, 1 to 3. The figure illustrates the output waveforms of the 3-field interlaced drive.

#### Gate selection

GS = 0					
FLD1-0	01	11			
Field	-	1	2	3	
Gate					
G1	O	O			
G2	O		O		
G3	O				O
G4	O	O			
G5	O		O		
G6	O				O
G7	O	O			
G8	O		O		
G9	O				O
•	•	•	•	•	•
•	•	•	•	•	•
•	•	•	•	•	•
G237	O				O
G238	O	O			
G239	O		O		
G240	O				O

GS = 1					
FLD1-0	01	11			
Field	-	1	2	3	
Gate					
G240	O	O			
G239	O		O		
G238	O				O
G237	O	O			
G236	O		O		
G235	O				O
G234	O	O			
G233	O		O		
G232	O				O
•	•	•	•	•	•
•	•	•	•	•	•
•	•	•	•	•	•
G4	O				O
G3	O	O			
G2	O		O		
G1	O				O

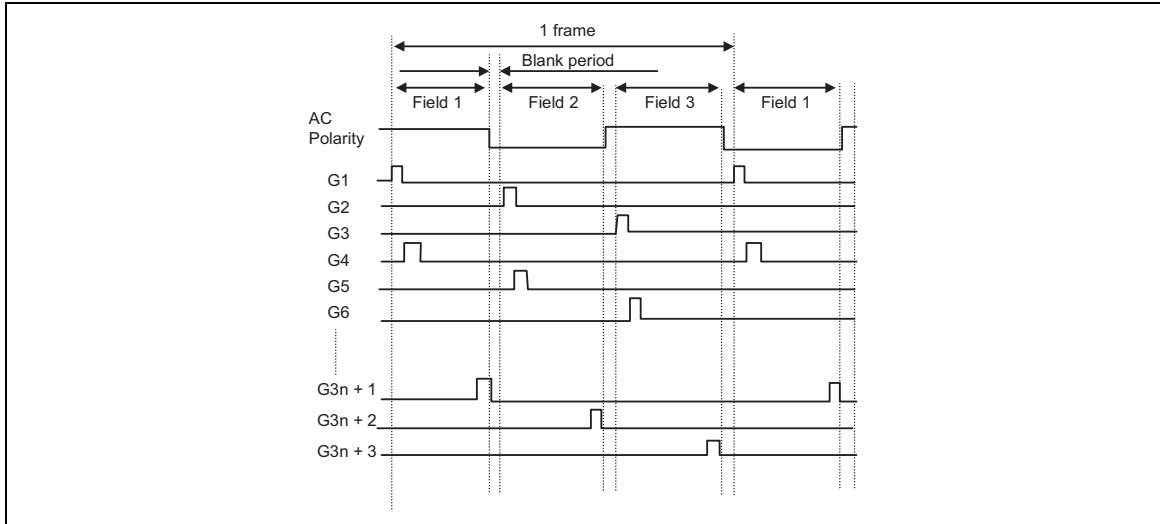

Gate output timing in 3-field interlaced drive

### AC Timing

The AC timings of frame inversion AC drive, 3-field interlaced drive, and n-raster-row inversion drive are illustrated as follows. In case of frame inversion AC drive, alternation occurs at the completion of drawing one frame, followed by a blank, which lasts for 16H periods. In this case, all outputs from the gate are Vgoff outputs. In case of interlaced drive, alternation occurs at the completion of drawing one field, followed by a blank. The total period of the blanks in one frame amounts to 16H period. In case of n-raster-row, a blank lasting 16H period is inserted after drawing a full screen.

During interlaced drive, make the numbers of back and front porches more than that of field.

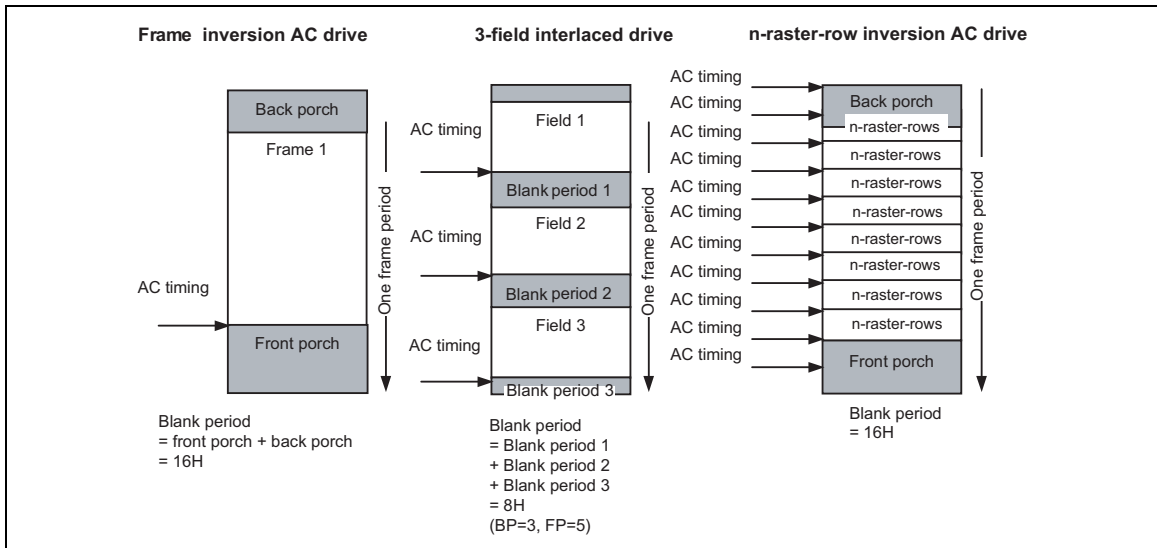

AC timing

## Frame-Frequency Adjustment Function

The HD66789 incorporates frame frequency adjustment function. The frame frequency during the liquid crystal drive is adjusted by the instruction setting (DIV, RTN) while keeping the oscillation frequency fixed.

Setting the oscillation frequency high in advance allows switching the frame frequency in accordance to the kind of displayed picture (i.e. moving/still picture). When displaying a still picture, set the frame frequency low to save power consumption, while setting the frame frequency high when displaying a moving picture which requires high-speed switching of screens.

### Relationship between Liquid Crystal Drive Duty and Frame Frequency

The relationship between the liquid crystal drive duty and the frame frequency is calculated by the following formula. The frame frequency is adjusted through the instruction setting with the 1-H period adjustment bit (RTN bit) and the operation clock division bit (DIV bit).

(Formula for the frame frequency)

$$\text{Frame frequency} = \frac{f_{\text{osc}}}{\text{Clock cycles per raster-row} \times \text{division ratio} \times (\text{Line} + \text{BP} + \text{FP})} \quad [\text{Hz}]$$

$f_{\text{osc}}$ : R-C oscillation frequency

Line: number of drive raster-rows (NL bit)

Clock cycles per raster-row: RTN bit

Division ratio: DIV bit

The number of raster-rows for the front porch: FP

The number of raster-rows for the back porch: BP

### Calculation Example      The maximum frame frequency = 60 Hz

Number of drive raster-rows: 240

1-H period: 16 clock cycles (RTN3-0 = 0000)

Operation clock division ratio: 1 division

$$f_{\text{osc}} = 60 \text{ Hz} \times (0 + 16) \text{ clock} \times 1 \text{ division} \times (240 + 16) \text{ lines} = 246 \text{ (kHz)}$$

In this case, the R-C oscillation frequency becomes 246 kHz. Adjust the external resistor to the R-C oscillator to 246 kHz.



### Screen -split Drive Function

The HD66789 allows selectively driving two screens at arbitrary positions with the screen-drive position registers (R42 and R43). Only the raster-rows required to display two screens at arbitrary positions are selectively driven to reduce power consumption.

The first screen drive position register (R42) specifies the start line (SS17-10) and the end line (SE17-10) for displaying the first screen. The second screen drive position register (R43) specifies the start line (SS27-20) and the end line (SE27-20) for displaying the second screen. The second screen control is effective when the SPT bit is set to 1. The total number of raster-rows driven for displaying the first and second screens must be less than the number of liquid crystal drive raster-rows.

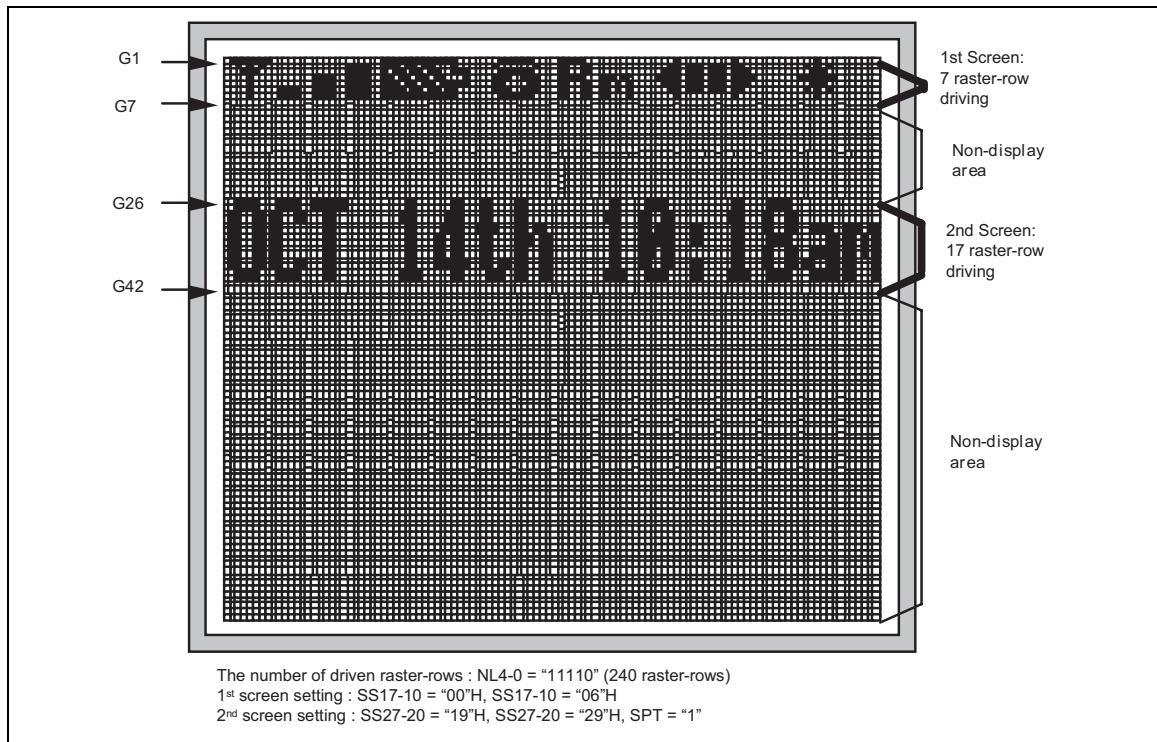

Screen-split Drive

### Notes to the setting of 1st/2nd screen drive position registers

When making settings for the start line (SS17-10) and end line (SE17-10) of the first screen drive position register (R42), and the start line (SS27-20) and end line (SE27-20) of the second screen drive position register (R43) with the HD66789, it is necessary to satisfy the following conditions to display screens correctly.

#### One-screen Drive (SPT = 0)

Register Settings	Display Operation
$(SE17-10) - (SS17-10) = NL$	Full screen display The area of $(SE17-10) - (SS17-10)$ is normally displayed.
$(SE17-10) - (SS17-10) < NL$	Partial screen display The area of $(SE17-10) - (SS17-10)$ is normally displayed. The rest of the area is white display irrespective of data in RAM.
$(SE17-10) - (SS17-10) > NL$	Setting disabled

Note 1)  $SS17-10 \leq SE17-0 \leq "EF"H$   
 Note 2) Setting disabled for SS27-20 and SE27-20.

#### Two-screen Drive (SPT = 1)

Register Settings	Display Operation
$((SE17-10) - (SS17-10)) + ((SE27-20) - (SS27-20)) = NL$	Full screen display The area of $(SE27-20) - (SS17-10)$ is normally displayed.
$((SE17-10) - (SS17-10)) + ((SE27-20) - (S27-20)) < NL$	Partial screen display The area of $(SE27-10) - (SS17-10)$ is normally displayed. The rest of the area is white display irrespective of data in RAM.
$((SE17-10) - (SS17-10)) + ((SE27-20) - (SS27-20)) > NL$	Setting disabled

Note 1) Make sure that  $SS17-10 \leq SE17-10 < SS27-20 \leq SE27-20 \leq EFH$ .  
 Note 2) Make sure that  $((SE27-20) - (SS17-10)) \leq NL$ .

The setting for the driver output in the non-display area during the partial display is changeable according to the characteristics of the display panel.

#### Source outputs in non-display area

PT1	PT0	Source Output for Non-display Area	
		Positive Polarity	Negative Polarity
0	0	V31	V0
0	1	V31	V0
1	0	GND	GND
1	1	High-Z	High-Z

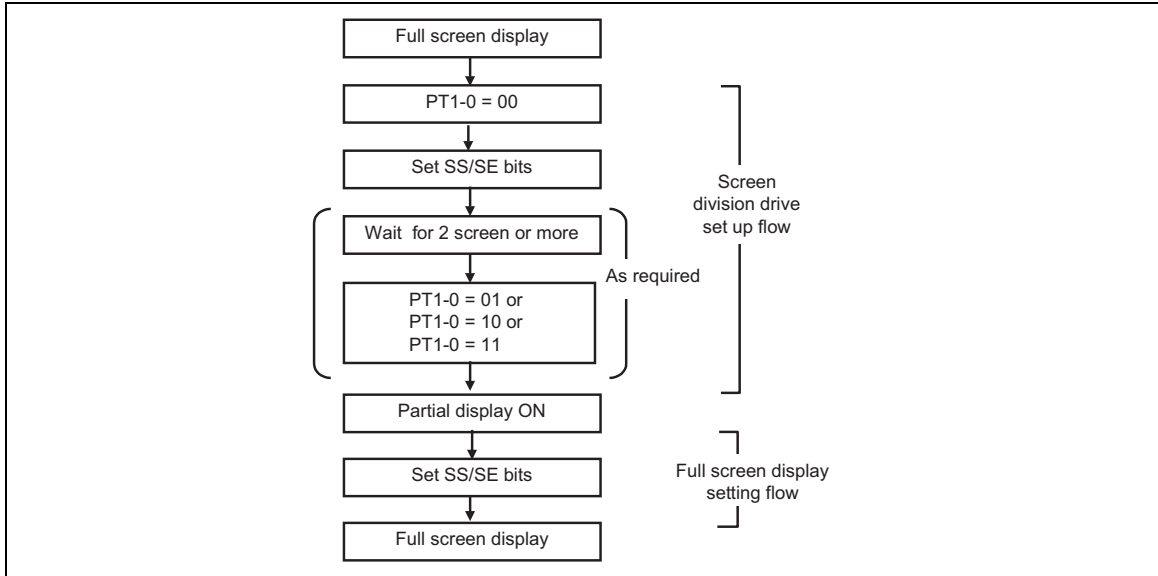

**Partial display setting flow**

**Absolute Maximum Values**

Item	Symbol	Unit	Value	Notes
Power supply voltage (1)	Vcc	V	-0.3 ~ + 4.6	1, 2
Power supply voltage (2)	Vci - GND	V	-0.3 ~ + 4.6	1, 2
Power supply voltage (3)	DDVDH - GND	V	-0.3 ~ + 6.0	1, 2
Power supply voltage (4)	GND -VCL	V	-0.3 ~ + 4.6	1, 2
Power supply voltage (5)	DDVDH - VCL	V	-0.3 ~ + 9.0	1
Power supply voltage (6)	VGH - GND	V	-0.3 ~ + 18.5	1, 2
Power supply voltage (7)	GND - VGL	V	-0.3 ~ + 18.5	1, 2
Input voltage	Vt	V	-0.3 ~ Vcc + 0.3	1
Operating temperature	Topr	°C	-40 ~ + 85	1, 3
Storage temperature	Tstg	°C	-55 ~ + 110	1

Note 1) The LSI may be permanently damaged if it is used under the condition exceeding the above absolute maximum values. It is also recommended to use the LSI within the limit of its electric characteristics during normal operation. Exceeding the conditions may lead to malfunction of LSI and affect its credibility.

Note 2) The voltage from GND.

Note 3) The DC and AC characteristics of chip and wafer products are guaranteed at 85 °C.

**Electric Characteristics (T.B.D.)****DC Characteristics** $(V_{CC} = 1.8 \text{ to } 3.7 \text{ V}, T_a = -40 \text{ to } +85^\circ\text{C}^{\text{Note 1}})$ 

Item	Symbol	Unit	Test Condition	Min	Typ	Max	Notes
Input high voltage	$V_{IH}$	V	$V_{CC} = 1.8 \text{ to } 3.7 \text{ V}$	$0.7 V_{CC}$	—	$V_{CC}$	2, 3
Input low voltage (1) (OSC1 pin)	$V_{IL1}$	V	$V_{CC} = 1.8 \text{ to } 3.7 \text{ V}$	-0.3	—	$0.15V_{CC}$	2, 3
Input low voltage (2) (Except OSC1 pin)	$V_{IL2}$	V	$V_{CC}=1.8\text{V to } 2.4\text{V}$	-0.3	—	$0.15V_{CC}$	2, 3
			$V_{CC}=2.4\text{V to } 3.7\text{V}$	-0.3	—	$0.2V_{CC}$	2, 3
Output high voltage (1) (DB0-17 pins)	$V_{OH1}$	V	$I_{OH} = -0.1 \text{ mA}$	$0.75V_{CC}$	—	—	2
Output low voltage (1) (DB0-17 pins)	$V_{OL1}$	V	$V_{CC} = 1.8 \text{ to } 2.4 \text{ V},$ $I_{OL} = 0.1 \text{ mA}$	—	—	$0.2 V_{CC}$	2
			$V_{CC} = 2.4 \text{ to } 3.7 \text{ V},$ $I_{OL} = 0.1 \text{ mA}$	—	—	$0.15V_{CC}$	2
I/O leakage current	$I_{Li}$	$\mu\text{A}$	$V_{in} = 0 \text{ to } V_{CC}$	-1	—	1	4
Current consumption during normal operation ( $V_{CC} - \text{GND}$ )	$I_{OP}$	$\mu\text{A}$	R-C oscillation; $f_{osc} =$ 250kHz (240line) $V_{CC} = 3.0 \text{ V},$ $T_a = 25^\circ\text{C},$ RAM data 0000h	—	190	300	5, 6
Current consumption during standby mode ( $V_{CC} - \text{GND}$ )	$I_{ST}$	$\mu\text{A}$	$V_{CC} = 3\text{V}, T_a \leq 50^\circ\text{C}$	—	0.1	5	
			$V_{CC} = 3\text{V}, T_a > 50^\circ\text{C}$	—	—	20	5
Liquid Crystal Power Current (DDVDH-GND)	$I_{LCD}$	$\mu\text{A}$	$V_{CC}=3\text{V}, V_{LCD}=5.5\text{V},$ $V_{DH}=5.0\text{V}, \text{CR}$ Oscillation; $f_{osc}=250\text{kHz}(240\text{line}),$ $T_a=25^\circ\text{C},$ RAMdata:0000h, REV="0", SAP="001", VRN4-0="0", PKP52- 00="0", PRP12-00="0", VRN4-0=VRP4-0="0" PKP52-00="0", PRP12- 00="0"	—	500	650	5, 6
Liquid Crystal Drive Voltage(DDVDH-GND)	$V_{LCD}$	V	—	4.5	—	5.5	—
Output Voltage deviation	$\Delta V_o$	mV	—	—	5	—	7
Variation of average output voltage		mV	—	—	—	35	8

**AC Characteristics**

( $V_{CC} = 1.7$  to  $3.7$  V,  $T_a = -40$  to  $+85^\circ\text{C}$  <sup>Note 1</sup>)

**Clock Characteristics ( $V_{CC} = 1.8$  to  $3.7$  V)**

Item	Symbol	Unit	Test Condition	Min	Typ	Max	Notes
External clock frequency	fcp	kHz	$V_{CC} = 1.8$ to $3.3$ V	100	270	600	9
External clock duty ratio	Du	%	$V_{CC} = 1.8$ to $3.3$ V	45	50	55	9
External clock rise time	trc	$\mu\text{s}$	$V_{CC} = 1.8$ to $3.3$ V	—	—	0.2	9
External clock fall time	tfcp	$\mu\text{s}$	$V_{CC} = 1.8$ to $3.3$ V	—	—	0.2	9
R-C oscillation clock	fOSC	kHz	Rf = TBD $V_{CC} = 3$ V	244	305	366	10

**80-system Bus Interface Timing Characteristics**

**Normal Write Mode (HWM=0) ( $V_{CC} = 1.8$  to  $2.4$  V)**

Item	Symbol	Unit	Test Condition	Min	Typ	Max	
Bus cycle time	Write	t <sub>CYCW</sub>	ns	Figure 2	600	—	—
	Read	t <sub>CYCR</sub>	ns	Figure 2	800	—	—
Write low-level pulse width	PW <sub>LW</sub>	ns	Figure 2	90	—	—	
Read low-level pulse width	PW <sub>LR</sub>	ns	Figure 2	350	—	—	
Write high-level pulse width	PW <sub>HW</sub>	ns	Figure 2	300	—	—	
Read high-level pulse width	PW <sub>HR</sub>	ns	Figure 2	400	—	—	
Write/Read rise/fall time	t <sub>WRr, WRf</sub>	ns	Figure 2	—	—	25	
Setup time	Write (RS to CS*)	t <sub>A</sub>	ns	Figure 2	0	—	—
	Read (RS to CS* RD*)	t <sub>A</sub>	ns	Figure 2	10	—	—
Address hold time	t <sub>A</sub>	ns	Figure 2	5	—	—	
VLD setup time	t <sub>VS</sub>	ns	Figure 2	60	—	—	
VLD hold time	t <sub>VH</sub>	ns	Figure 2	15	—	—	
Write data set up time	t <sub>DSW</sub>	ns	Figure 2	60	—	—	
Write data hold time	t <sub>H</sub>	ns	Figure 2	15	—	—	
Read data delay time	t <sub>DDR</sub>	ns	Figure 2	—	—	200	
Read data hold time	t <sub>DHR</sub>	ns	Figure 2	5	—	—	

**High-Speed Write Mode (HWM=1) (Vcc = 1.8 to 2.4 V)**

Item	Symbol	Unit	Test Condition	Min	Typ	Max	
Bus cycle time	Write	$t_{CYCW}$	ns	Figure 2	200	—	—
	Read	$t_{CYCR}$	ns	Figure 2	800	—	—
Write low-level pulse width	$PW_{LW}$	ns	Figure 2	90	—	—	
Read low-level pulse width	$PW_{LR}$	ns	Figure 2	350	—	—	
Write high-level pulse width	$PW_{HW}$	ns	Figure 2	90	—	—	
Read high-level pulse width	$PW_{HR}$	ns	Figure 2	400	—	—	
Write/Read rise/fall time	$t_{WRr, WRf}$	ns	Figure 2	—	—	25	
Set up time	Write (RS to CS*, WR*)		ns	Figure 2	0	—	—
	Read (RS to CS*, RD*)		ns	Figure 2	10	—	—
Address hold time		ns	Figure 2	5	—	—	
VLD setup time	$t_{VS}$	ns	Figure 2	60	—	—	
VLD hold time	$t_{VH}$	ns	Figure 2	15	—	—	
Write data set up time	$t_{DSW}$	ns	Figure 2	60	—	—	
Write data hold time	$t_H$	ns	Figure 2	15	—	—	
Read data delay time	$t_{DDR}$	ns	Figure 2	—	—	200	
Read data hold time	$t_{DHR}$	ns	Figure 2	5	—	—	

**Normal Write Mode (HWM=0) : Vcc = 2.4 to 3.7 V**

Item	Symbol	Unit	Test Condition	Min	Typ	Max	
Bus cycle time	Write	$t_{CYCW}$	ns	Figure 2	250	—	—
	Read	$t_{CYCR}$	ns	Figure 2	500	—	—
Write low-level pulse width	$PW_{LW}$	ns	Figure 2	40	—	—	
Read low-level pulse width	$PW_{LR}$	ns	Figure 2	250	—	—	
Write high-level pulse width	$PW_{HW}$	ns	Figure 2	70	—	—	
Read high-level pulse width	$PW_{HR}$	ns	Figure 2	200	—	—	
Write/Read rise/fall time		ns	Figure 2	—	—	25	
Set up time	Write (RS to CS*, WR*)		ns	Figure 2	0	—	—
	Read (RS to CS*, RD*)		ns	Figure 2	10	—	—
Address hold time	$t_{AH}$	ns	Figure 2	2	—	—	
VLD set up time	$t_{VS}$	ns	Figure 2	25	—	—	
VLD hold time	$t_{VH}$	ns	Figure 2	2	—	—	
Write data setup time	$t_{DSW}$	ns	Figure 2	25	—	—	
Write data hold time	$t_H$	ns	Figure 2	2	—	—	
Read data delay time	$t_{DDR}$	ns	Figure 2	—	—	200	
Read data hold time	$t_{DHR}$	ns	Figure 2	5	—	—	

## High-Speed Write Mode (HWM=1) : Vcc = 2.4 to 3.7 V

Item	Symbol	Unit	Test Condition	Min	Typ	Max
Bus cycle time	Write	$t_{CYCW}$	Figure 2	100	—	—
	Read	$t_{CYCR}$		500	—	—
Write low-level pulse width	$PW_{LW}$	ns	Figure 2	40	—	—
Read low-level pulse width	$PW_{LR}$	ns	Figure 2	250	—	—
Write high -level pulse width	$PW_{HW}$	ns	Figure 2	40	—	—
Read high -level pulse width	$PW_{HR}$	ns	Figure 2	200	—	—
Write/Read rise/fall time	$t_{WRr, WRf}$	ns	Figure 2	—	—	—
Set up time	Write (RS to CS*, WR*)	$t_{WRr, WRf}$	Figure 2	0	—	25
	Read (RS to CS*, RD*)			10	—	—
Address hold time	$t_{AH}$	ns	Figure 2	2	—	—
VLD set-up time	$t_{VS}$	ns	Figure 2	25	—	—
VLD hold time	$t_{VH}$	ns	Figure 2	2	—	—
Write data set up time	$t_{DSW}$	ns	Figure 2	25	—	—
Write data hold time	$t_H$	ns	Figure 2	2	—	—
Read data delay time	$t_{DDR}$	ns	Figure 2	—	—	200
Read data hold time	$t_{DHR}$	ns	Figure 2	5	—	—



## Clock Synchronized Serial Interface Timing Characteristics

V<sub>CC</sub> = 1.8 to 2.4 V

Item	Symbol	Unit	Test Condition	Min	Typ	Max	
Serial clock cycle time	Write (received)	t <sub>SCYC</sub>	us	Figure 3	0.1	—	20
	Read (transmitted)	t <sub>SCYC</sub>	us	Figure 3	0.5	—	20
Serial clock high-level pulse width	Write (received)	t <sub>SCH</sub>	ns	Figure 3	40	—	—
	Read (transmitted)	t <sub>SCH</sub>	ns	Figure 3	230	—	—
Serial clock low-level pulse width	Write (received)	t <sub>SCL</sub>	ns	Figure 3	40	—	—
	Read (transmitted)	t <sub>SCL</sub>	ns	Figure 3	230	—	—
Serial clock rise/fall time	t <sub>scr, tscf</sub>	ns	Figure 3	—	—	20	
Chip select set up time	t <sub>CSU</sub>	ns	Figure 3	20	—	—	
Chip select hold time	t <sub>CH</sub>	ns	Figure 3	60	—	—	
Serial input data set up time	t <sub>SISU</sub>	ns	Figure 3	30	—	—	
Serial input data hold time	t <sub>SIH</sub>	ns	Figure 3	30	—	—	
Serial input data delay time	t <sub>SOD</sub>	ns	Figure 3	—	—	200	
Serial input data hold time	t <sub>SOH</sub>	ns	Figure 3	5	—	—	

V<sub>CC</sub> = 2.4 to 3.3 V

Item	Symbol	Unit	Test Condition	Min	Typ	Max	
Serial clock cycle time	Write (receive)	t <sub>SCYC</sub>	us	Figure 3	0.1	—	20
	Read (send)	t <sub>SCYC</sub>	us	Figure 3	0.35	—	20
Serial clock high-level pulse width	Write (receive)	t <sub>SCH</sub>	ns	Figure 3	40	—	—
	Read (send)	t <sub>SCH</sub>	ns	Figure 3	150	—	—
Serial clock low-level pulse width	Write (receive)	t <sub>SCL</sub>	ns	Figure 3	40	—	—
	Read (send)	t <sub>SCL</sub>	ns	Figure 3	150	—	—
Serial clock rise/fall time	t <sub>scr, scf</sub>	ns	Figure 3	—	—	20	
Chip select set up time	t <sub>CSU</sub>	ns	Figure 3	20	—	—	
Chip select hold time	t <sub>CH</sub>	ns	Figure 3	60	—	—	
Serial input data set up time	t <sub>SISU</sub>	ns	Figure 3	30	—	—	
Serial input data hold time	t <sub>SIH</sub>	ns	Figure 3	30	—	—	
Serial output data delay time	t <sub>SOD</sub>	ns	Figure 3	—	—	130	
Serial output data hold time	t <sub>SOH</sub>	ns	Figure 3	5	—	—	

Reset Timing Characteristics ( $V_{CC} = 1.8$  to  $3.7$  V)

Item	Symbol	Unit	Test Condition	Min	Typ	Max
Reset low-level width	$t_{RES}$	ms	Figure 4	1	—	—
Reset rise time	$t_{RES}$	ns	Figure 4	—	—	10

**T.B.D.**

**RGB interface timing characteristics****18/16 bit RGB interface (HWM =1), Vcc = 1.8V to 2.4V**

Item	Symbol	Unit	Test Condition	min.	typ.	max.
VSYNC/HSYNC Set up time	tSYNCS	clock	Figure 5	0	—	1
ENABLE Set up time	tENS	ns	Figure 5	20	—	—
ENABLE Hold time	tENH	ns	Figure 5	80	—	—
VLD Set up time	tVLS	ns	Figure 5	20	—	—
VLD Hold time	tVLH	ns	Figure 5	80	—	—
DOTCLK "Low" Level pulse width	PWDL	ns	Figure 5	90	—	—
DOTCLK "High" Level pulse width	PWDH	ns	Figure 5	90	—	—
DOTCLK cycle time	tCYCD	ns	Figure 5	200	—	—
Data Set up time	tPDS	ns	Figure 5	20	—	—
Data Hole time	tPDH	ns	Figure 5	80	—	—
DOTCLK, VSYNC, HSYNC rising and falling time	trgbr, trgbf	ns	Figure 5	—	—	25

**18/16 bit RGB interface (HWM = 1), Vcc = 2.4V to 3.7 V**

Item	Symbol	Unit	Test Condition	min.	typ.	max.
VSYNC/HSYNC Set up time	tSYNCS	clock	Figure 5	0	—	1
ENABLE Set up time	tENS	ns	Figure 5	10	—	—
ENABLE Hold time	tENH	ns	Figure 5	20	—	—
VLD Set up time	tVLS	ns	Figure 5	10	—	—
VLD Hold time	tVLH	ns	Figure 5	40	—	—
DOTCLK "Low" Level pulse width	PWDL	ns	Figure 5	40	—	—
DOTCLK "High" Level pulse width	PWDH	ns	Figure 5	40	—	—
DOTCLK cycle time	tCYCD	ns	Figure 5	100	—	—
Data Set up time	tPDS	ns	Figure 5	10	—	—
Data Hole time	tPDH	ns	Figure 5	40	—	—
DOTCLK, VSYNC, HSYNC rising and falling time	trgbr, trgbf	ns	Figure 5	—	—	25

6 bit RGB interface (HWM = 1), V<sub>cc</sub> = 1.8V to 2.4 V

Item	Symbol	Unit	Test Condition	min.	typ.	max.
VSYNC/HSYNC Set up time	tSYNCS	clock	Figure 5	0	—	1
ENABLE Set up time	tENS	ns	Figure 5	20	—	—
ENABLE Hold time	tENH	ns	Figure 5	50	—	—
VLD Set up time	tVLS	ns	Figure 5	20	—	—
VLD Hold time	tVLH	ns	Figure 5	65	—	—
DOTCLK "Low" Level pulse width	PWDL	ns	Figure 5	50	—	—
DOTCLK "High" Level pulse width	PWDH	ns	Figure 5	50	—	—
DOTCLK cycle time	tCYCD	ns	Figure 5	120	—	—
Data Set up time	tPDS	ns	Figure 5	20	—	—
Data Hold time	tPDH	ns	Figure 5	65	—	—
DOTCLK, VSYNC, HSYNC rising and falling time	trgbr, trgbf	ns	Figure 5	—	—	25

6 bit RGB interface (HWM = 1), V<sub>cc</sub> = 2.4V to 3.3 V

Item	Symbol	Unit	Test Condition	min.	typ.	max.
VSYNC/HSYNC Set up time	tSYNCS	clock	Figure 5	0	—	1
ENABLE Set up time	tENS	ns	Figure 5	10	—	—
ENABLE Hold time	tENH	ns	Figure 5	20	—	—
VLD Set up time	tVLS	ns	Figure 5	10	—	—
VLD Hold time	V <sub>cc</sub> =2,4 to 2,7V tVLH	ns	Figure 5	40	—	—
	V <sub>cc</sub> =2,7 to 3,7V tVLH	ns	Figure 5	30	—	—
DOTCLK "Low" Level pulse width	PWDL	ns	Figure 5	30	—	—
DOTCLK "High" Level pulse width	PWDH	ns	Figure 5	30	—	—
DOTCLK cycle time	tCYCD	ns	Figure 5	70	—	—
Data Set up time	tPDS	ns	Figure 5	10	—	—
Data Hole time	V <sub>cc</sub> =2,4 to 2,7V tPDH	ns	Figure 5	40	—	—
	V <sub>cc</sub> =2,7 to 3,7V tPDH	ns	Figure 5	30	—	—
DOTCLK, VSYNC, HSYNC rising and falling time	trgbr, trgbf	ns	Figure 5	—	—	25

Liquid crystal driver output characteristics

Item	Symbol	Unit	Test conditions	min.	typ.	max.	Note
Driver output delay time	t <sub>dd</sub>	μs	V <sub>cc</sub> =3V, V <sub>LCD</sub> =5.5V, V <sub>DH</sub> =5.0V, CR oscillation ;f <sub>osc</sub> =270kHz(240 lines), Ta=25℃, REV="0", SAP="001", VRN4-0="0",VRP4-0="0" PKP52-00="0",PRP12-00="0" PKP52-00="0",PRP12-00="0" All pins changes at the same time from same grayscale. The time till output level reaches 35mV when VCOM polarity changes. Load resistance R=10kΩ, Load capacity C=20pF	—	40	—	(11)

T.B.D.

Electrical Characteristics Notes

- For bare die and wafer products, specified up to 85°C.
- The following three circuits are I pin, I/O pin, O pin configurations.

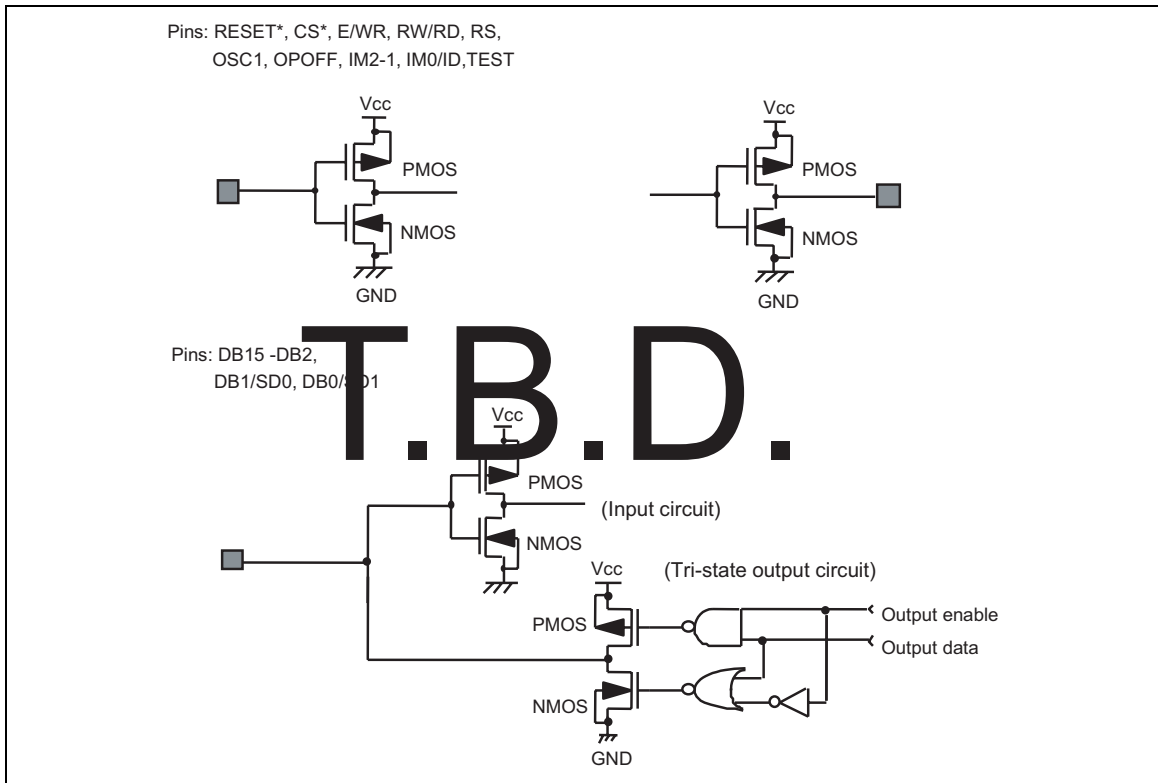

- The TEST pin must be grounded and the IM2/1 and IM0/ID pins must be grounded or connected to Vcc.
- This applies to the resistor value (RSEG) between VSH, GND pins and segment signal pins.

T.B.D.

- This excludes the current flowing through output drive MOSs. This excludes the current flowing through the input/output units. The input level must be fixed high or low because through current increases if the CMOS input is left floating. Even if the CS pin is low or high when an access with the interface pin is not performed, current consumption does not change.
- The following figure shows the relationship between the operation frequency and current consumption.

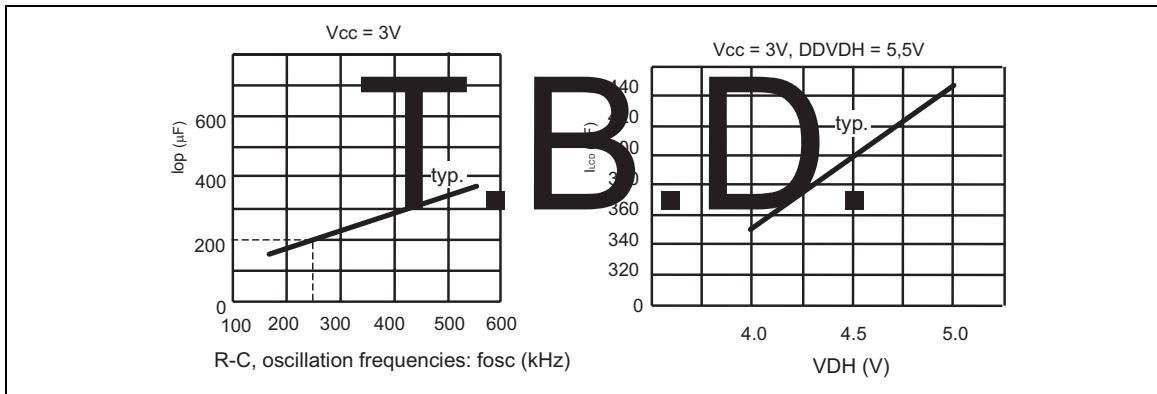

- This is a voltage difference for the neighboring outputs under the same display condition. The output voltage deviation is a reference value.
- The fluctuation of average output voltage indicates the difference of average output voltage between chips. The average output voltage is an average voltage within a chip under the same display condition.
- Applies to the external clock input (figure ).

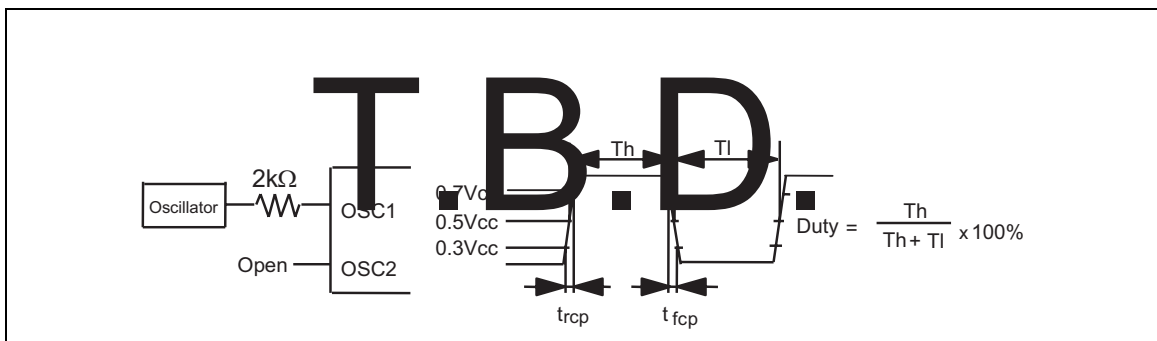

- Applies to the internal oscillator operations using external oscillation resistor Rf (figure and table).



**External Resistance Value and R-C Oscillation Frequency (Referential Data)**

External Resistance (Rf)	R-C Oscillation Frequency: fosc				
	Vcc = 1.8 V	Vcc = 2 V	Vcc = 2.4 V	Vcc = 3 V	Vcc = 3.3 V
110 kΩ	299	333	372	401	411
150 kΩ	234	258	284	305	311
180 kΩ	202	222	243	258	263
200 kΩ	186	206	222	235	240
240 kΩ	160	179	188	198	202
270 kΩ	145	164	169	177	181
300 kΩ	132	143	153	161	163
390 kΩ	106	113	121	126	128
430 kΩ	97	104	110	115	116

11. Applies to the internal oscillator operations using external oscillation resistor Rf (figure and table).

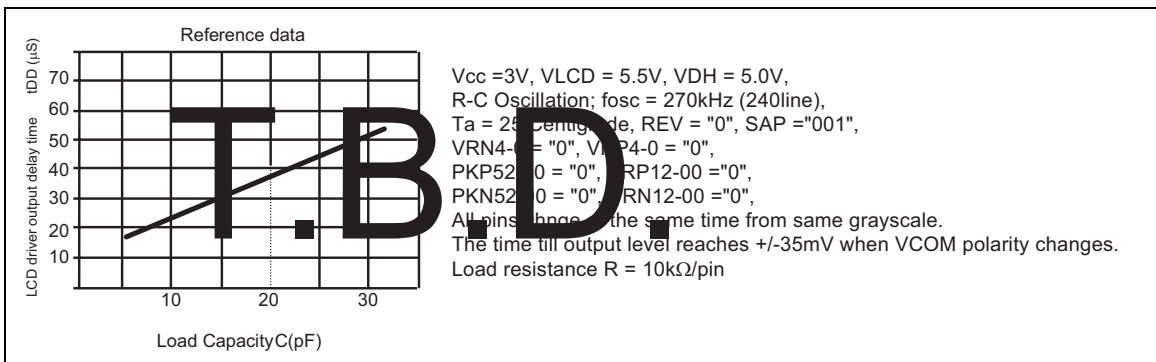

Load circuits for measuring AC characteristics

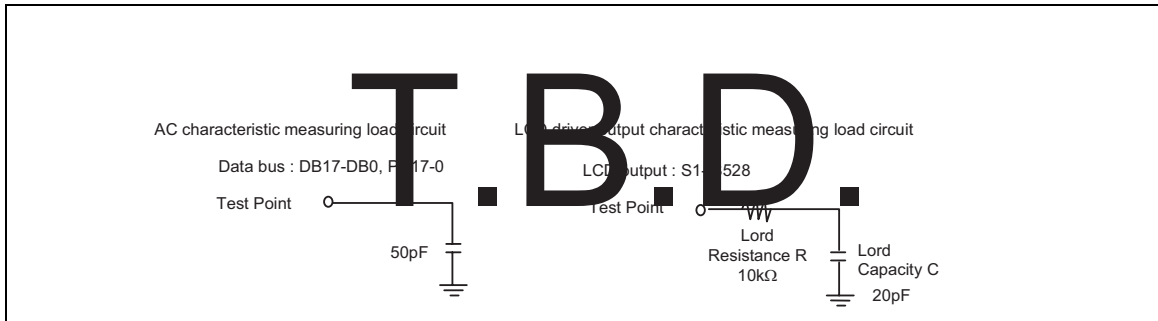

80-system Bus Operation

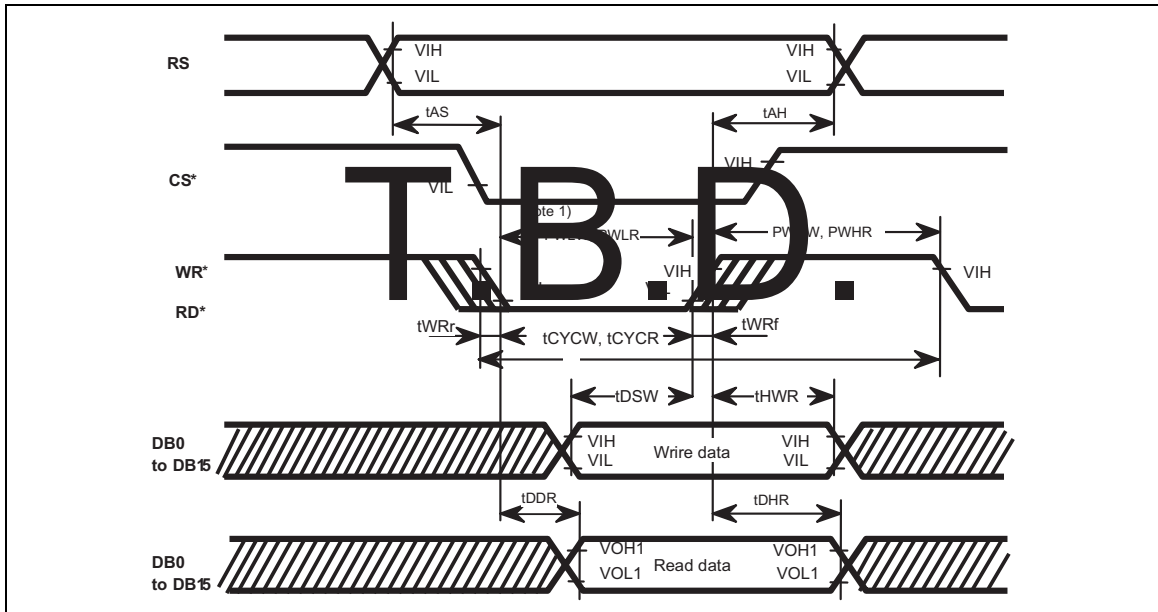

Note 1) PWLW and PWLR is specified in the overlapped period when CS\* is low and WR\* or RD\* is low.

Note 2) Parallel data transfer is enabled on the DB15-8 pins when the 8-bit bus interface is used. Fix the DB7-0 pins to Vcc or GND.



**Clock Synchronized Serial Interface Operation**

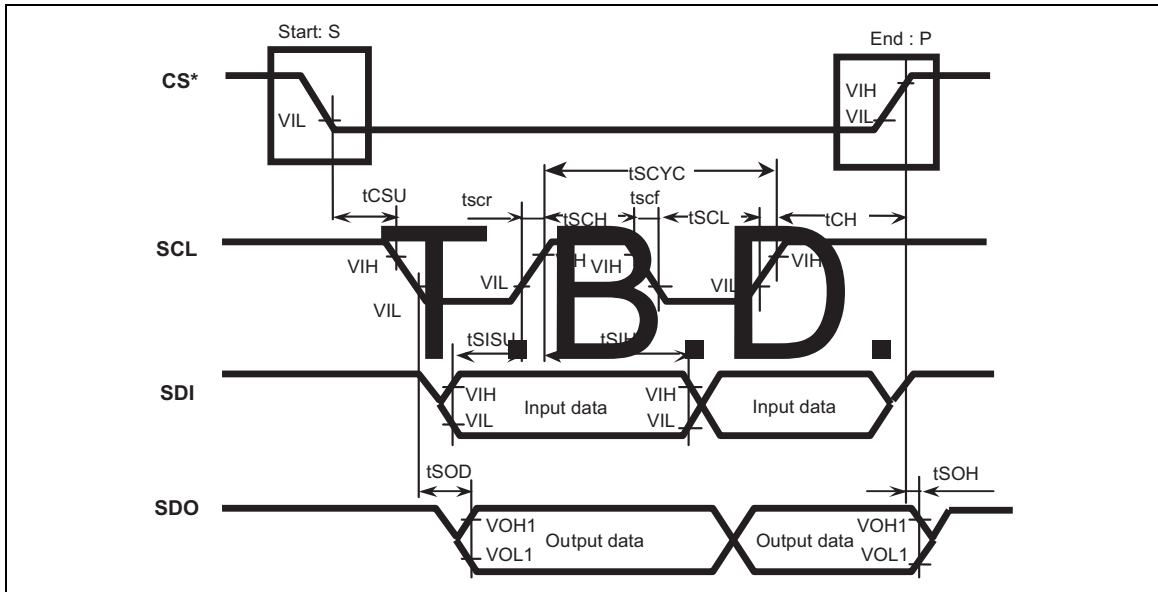

**RESET Operation**



RGB I/F Operation

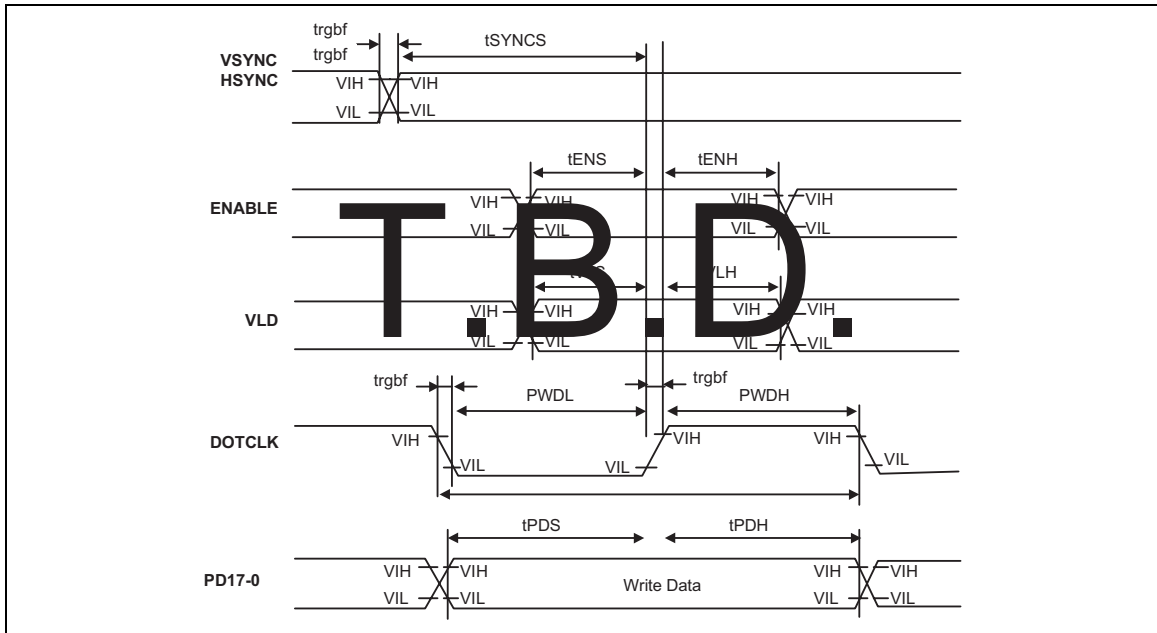

Liquid crystal Driver Output

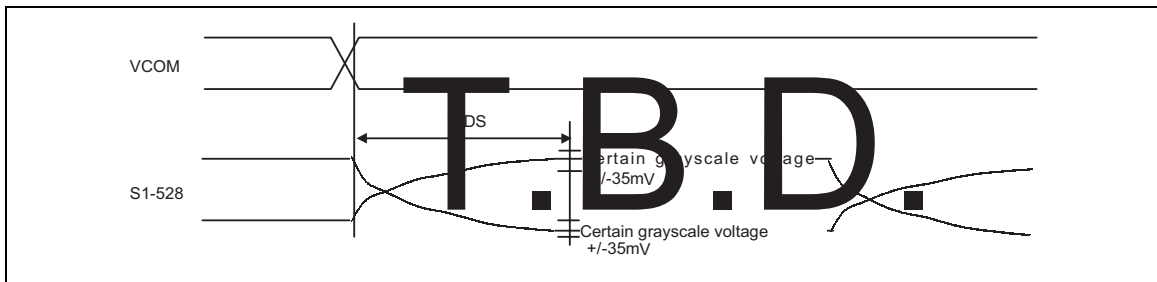

---

**Renesas Technology Corp.** Sales Strategic Planning Div. Nippon Bldg., 2-6-2, Ohte-machi, Chiyoda-ku, Tokyo 100-0004, Japan

---

**Keep safety first in your circuit designs!**

1. Renesas Technology Corporation puts the maximum effort into making semiconductor products better and more reliable, but there is always the possibility that trouble may occur with them. Trouble with semiconductors may lead to personal injury, fire or property damage. Remember to give due consideration to safety when making your circuit designs, with appropriate measures such as (i) placement of substitutive, auxiliary circuits, (ii) use of nonflammable material or (iii) prevention against any malfunction or mishap.

**Notes regarding these materials**

1. These materials are intended as a reference to assist our customers in the selection of the Renesas Technology Corporation product best suited to the customer's application; they do not convey any license under any intellectual property rights, or any other rights, belonging to Renesas Technology Corporation or a third party.
  2. Renesas Technology Corporation assumes no responsibility for any damage, or infringement of any third-party's rights, originating in the use of any product data, diagrams, charts, programs, algorithms, or circuit application examples contained in these materials.
  3. All information contained in these materials, including product data, diagrams, charts, programs and algorithms represents information on products at the time of publication of these materials, and are subject to change by Renesas Technology Corporation without notice due to product improvements or other reasons. It is therefore recommended that customers contact Renesas Technology Corporation or an authorized Renesas Technology Corporation product distributor for the latest product information before purchasing a product listed herein.  
The information described here may contain technical inaccuracies or typographical errors.  
Renesas Technology Corporation assumes no responsibility for any damage, liability, or other loss rising from these inaccuracies or errors.  
Please also pay attention to information published by Renesas Technology Corporation by various means, including the Renesas Technology Corporation Semiconductor home page (<http://www.renesas.com>).
  4. When using any or all of the information contained in these materials, including product data, diagrams, charts, programs, and algorithms, please be sure to evaluate all information as a total system before making a final decision on the applicability of the information and products. Renesas Technology Corporation assumes no responsibility for any damage, liability or other loss resulting from the information contained herein.
  5. Renesas Technology Corporation semiconductors are not designed or manufactured for use in a device or system that is used under circumstances in which human life is potentially at stake. Please contact Renesas Technology Corporation or an authorized Renesas Technology Corporation product distributor when considering the use of a product contained herein for any specific purposes, such as apparatus or systems for transportation, vehicular, medical, aerospace, nuclear, or undersea repeater use.
  6. The prior written approval of Renesas Technology Corporation is necessary to reprint or reproduce in whole or in part these materials.
  7. If these products or technologies are subject to the Japanese export control restrictions, they must be exported under a license from the Japanese government and cannot be imported into a country other than the approved destination.  
Any diversion or reexport contrary to the export control laws and regulations of Japan and/or the country of destination is prohibited.
  8. Please contact Renesas Technology Corporation for further details on these materials or the products contained therein.
- 

<http://www.renesas.com>

Copyright © 2003. Renesas Technology Corporation, All rights reserved. Printed in Japan.  
Colophon 0.0

**Revision Record**

<b>Rev.</b>	<b>Date</b>	<b>Contents of Modification</b>	<b>Drawn by</b>	<b>Approved by</b>
0.1	2003.05.08	First issue		

---