



HD74AC245/HD74ACT245

Octal Bi-directional Transceiver with 3-State Input/Output

REJ03D0263-0200Z
(Previous ADE-205-384 (Z))
Rev.2.00
Jul.16.2004

Description

The HD74AC245/HD74ACT245 contains eight non-inverting bidirectional buffers with 3-state outputs and is intended for bus-oriented applications. Current sinking capability is 24 mA at both the A and B ports. The Transmit/Receive (T/ \bar{R}) input determines the direction of data flow through the bidirectional transceiver. Transmit (active-High) enables data from A ports to B ports; Receive (active-Low) enables data from B ports to A ports. The Output Enable input, when High, disables, both A and B ports by placing them in a High Z condition.

Features

- Noninverting Buffers
- Bi-directional Data Path
- A and B Outputs Source/Sink 24 mA
- HD74ACT245 has TTL-Compatible Inputs
- Ordering Information: Ex. HD74AC245

Part Name	Package Type	Package Code	Package Abbreviation	Taping Abbreviation (Quantity)
HD74AC245P	DIP-20 pin	DP-20N, -20NEV	P	—
HD74AC245FPEL	SOP-20 pin (JEITA)	FP-20DAV	FP	EL (2,000 pcs/reel)
HD74AC245RPEL	SOP-20 pin (JEDEC)	FP-20DBV	RP	EL (1,000 pcs/reel)
HD74AC245TELL	TSSOP-20 pin	TTP-20DAV	T	ELL (2,000 pcs/reel)

Notes: 1. Please consult the sales office for the above package availability.

2. The packages with lead-free pins are distinguished from the conventional products by adding V at the end of the package code.



Pin Names

- \overline{OE} Output Enable Input
- T/\overline{R} Transmit/Receive Input
- A₀ to A₇ Side A 3-State Inputs or 3-State Outputs
- B₀ to B₇ Side B 3-State Inputs or 3-State Outputs

Pin Arrangement

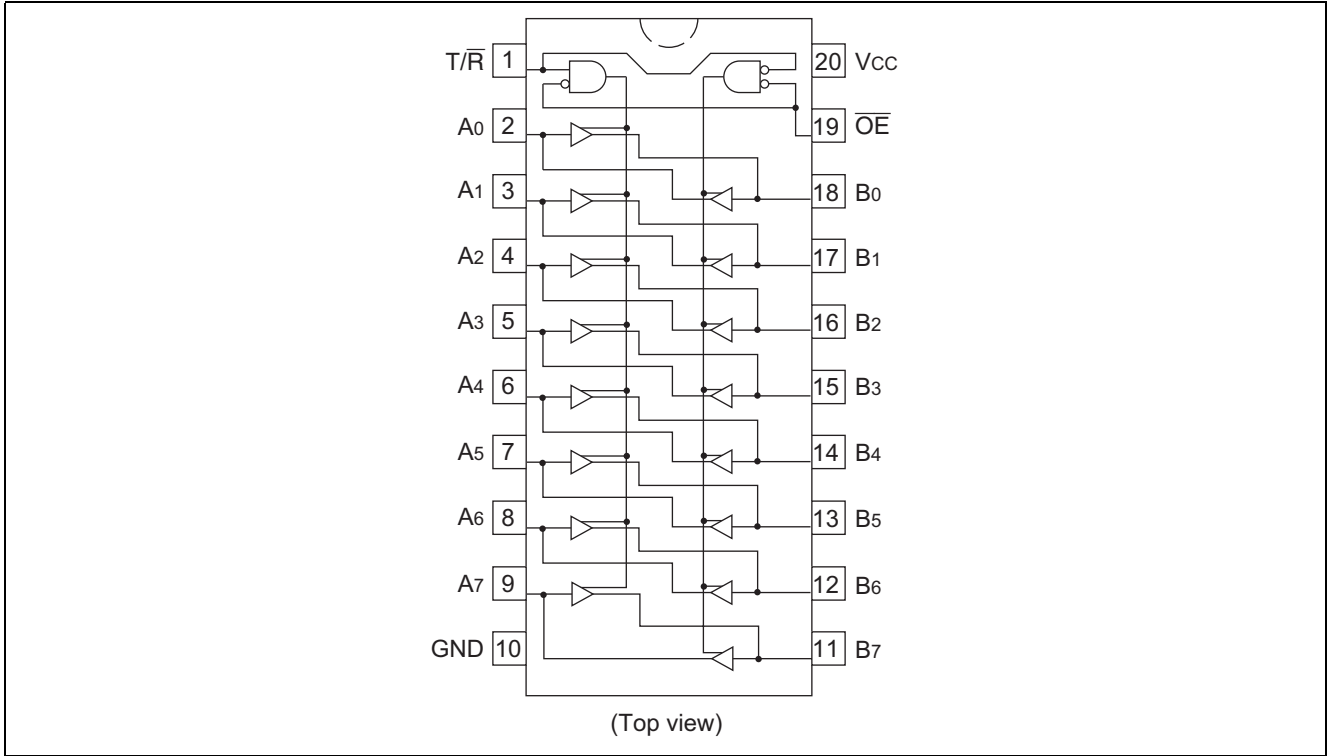

Truth Tables

Inputs		Outputs
\overline{OE}	T/\overline{R}	
L	L	Bus B Data to Bus A
L	H	Bus A Data to Bus B
H	X	High Z State

- H : High Voltage Level
- L : Low Voltage Level
- X : Immaterial

Absolute Maximum Ratings

Item	Symbol	Ratings	Unit	Condition
Supply voltage	V _{CC}	-0.5 to 7	V	
DC input diode current	I _{IK}	-20	mA	V _I = -0.5V
		20	mA	V _I = V _{CC} +0.5V
DC input voltage	V _I	-0.5 to V _{CC} +0.5	V	
DC output diode current	I _{OK}	-50	mA	V _O = -0.5V
		50	mA	V _O = V _{CC} +0.5V
DC output voltage	V _O	-0.5 to V _{CC} +0.5	V	
DC output source or sink current	I _O	±50	mA	
DC V _{CC} or ground current per output pin	I _{CC} , I _{GND}	±50	mA	
Storage temperature	T _{stg}	-65 to +150	°C	

Recommended Operating Conditions: HD74AC245

Item	Symbol	Ratings	Unit	Condition
Supply voltage	V_{CC}	2 to 6	V	
Input and Output voltage	V_I, V_O	0 to V_{CC}	V	
Operating temperature	T_a	-40 to +85	°C	
Input rise and fall time (except Schmitt inputs) V_{IN} 30% to 70% V_{CC}	tr, tf	8	ns/V	$V_{CC} = 3.0V$
				$V_{CC} = 4.5 V$
				$V_{CC} = 5.5 V$

DC Characteristics: HD74AC245

Item	Sym- bol	Vcc (V)	$T_a = 25^\circ C$			$T_a = -40$ to $+85^\circ C$		Unit	Condition			
			min.	typ.	max.	min.	max.					
Input Voltage	V_{IH}	3.0	2.1	1.5	—	2.1	—	V	$V_{OUT} = 0.1 V$ or $V_{CC} - 0.1 V$			
		4.5	3.15	2.25	—	3.15	—					
		5.5	3.85	2.75	—	3.85	—					
	V_{IL}	3.0	—	1.50	0.9	—	0.9		V	$V_{OUT} = 0.1 V$ or $V_{CC} - 0.1 V$		
		4.5	—	2.25	1.35	—	1.35					
		5.5	—	2.75	1.65	—	1.65					
Output voltage	V_{OH}	3.0	2.9	2.99	—	2.9	—	V		$V_{IN} = V_{IL}$ or V_{IH} $I_{OUT} = -50 \mu A$		
		4.5	4.4	4.49	—	4.4	—					
		5.5	5.4	5.49	—	5.4	—					
		3.0	2.58	—	—	2.48	—		$V_{IN} = V_{IL}$ or V_{IH}		$I_{OH} = -12 mA$	
		4.5	3.94	—	—	3.80	—				$I_{OH} = -24 mA$	
		5.5	4.94	—	—	4.80	—				$I_{OH} = -24 mA$	
	V_{OL}	3.0	—	0.002	0.1	—	0.1		V	$V_{IN} = V_{IL}$ or V_{IH} $I_{OUT} = 50 \mu A$		
		4.5	—	0.001	0.1	—	0.1					
		5.5	—	0.001	0.1	—	0.1					
		3.0	—	—	0.32	—	0.37				$V_{IN} = V_{IL}$ or V_{IH}	$I_{OL} = 12 mA$
		4.5	—	—	0.32	—	0.37					$I_{OL} = 24 mA$
		5.5	—	—	0.32	—	0.37					$I_{OL} = 24 mA$
Input leakage current	I_{IN}	5.5	—	—	± 0.1	—	± 1.0	μA	$V_{IN} = V_{CC}$ or GND			
3 State current	I_{OZ}	5.5	—	—	± 0.5	—	± 5.0	μA	$V_{IN(OE)} = V_{IL}, V_{IH}$ $V_{IN} = V_{CC}$ or GND $V_{OUT} = V_{CC}$ or GND			
Dynamic output current*	I_{OLD}	5.5	—	—	—	86	—	mA	$V_{OLD} = 1.1 V$			
	I_{OHD}	5.5	—	—	—	-75	—	mA	$V_{OHD} = 3.85 V$			
Quiescent supply current	I_{CC}	5.5	—	—	8.0	—	80	μA	$V_{IN} = V_{CC}$ or ground			

*Maximum test duration 2.0 ms, one output loaded at a time.

Recommended Operating Conditions: HD74ACT245

Item	Symbol	Ratings	Unit	Condition
Supply voltage	V_{CC}	2 to 6	V	
Input and output voltage	V_I, V_O	0 to V_{CC}	V	
Operating temperature	T_a	-40 to +85	°C	
Input rise and fall time (except Schmitt inputs) V_{IN} 0.8 to 2.0 V	tr, tf	8	ns/V	$V_{CC} = 4.5V$ $V_{CC} = 5.5V$

DC Characteristics: HD74ACT245

Item	Symbol	V _{CC} (V)	Ta = 25°C			Ta = -40 to +85°C		Unit	Condition		
			min.	typ.	max.	min.	max.				
Input voltage	V _{IH}	4.5	2.0	1.5	—	2.0	—	V	V _{OUT} = 0.1 V or V _{CC} -0.1 V		
		5.5	2.0	1.5	—	2.0	—				
	V _{IL}	4.5	—	1.5	0.8	—	0.8		V _{OUT} = 0.1 V or V _{CC} -0.1 V		
		5.5	—	1.5	0.8	—	0.8				
Output voltage	V _{OH}	4.5	4.4	4.49	—	4.4	—	V	V _{IN} = V _{IL} or V _{IH} I _{OUT} = -50 μA		
		5.5	5.4	5.49	—	5.4	—				
		4.5	3.94	—	—	3.80	—			V _{IN} = V _{IL}	I _{OH} = -24 mA
		5.5	4.94	—	—	4.80	—				I _{OH} = -24 mA
	V _{OL}	4.5	—	0.001	0.1	—	0.1		V _{IN} = V _{IL} or V _{IH} I _{OUT} = 50 μA		
		5.5	—	0.001	0.1	—	0.1				
		4.5	—	—	0.32	—	0.37			V _{IN} = V _{IL}	I _{OL} = 24 mA
		5.5	—	—	0.32	—	0.37				I _{OL} = 24 mA
Input current	I _{IN}	5.5	—	—	±0.1	—	±1.0	μA	V _{IN} = V _{CC} or GND		
3 State current	I _{OZ}	5.5	—	—	±0.5	—	±5.0	μA	V _{IN} = V _{IL} , V _{IH} V _{OUT} = V _{CC} or GND		
I _{CC} /input current	I _{CCT}	5.5	—	0.6	—	—	1.5	mA	V _{IN} = V _{CC} -2.1 V		
Dynamic output current*	I _{OLD}	5.5	—	—	—	86	—	mA	V _{OLD} = 1.1 V		
	I _{OHD}	5.5	—	—	—	-75	—	mA	V _{OHD} = 3.85 V		
Quiescent supply current	I _{CC}	5.5	—	—	8.0	—	80	μA	V _{IN} = V _{CC} or ground		

*Maximum test duration 2.0 ms, one output loaded at a time.

AC Characteristics: HD74AC245

Item	Symbol	V _{CC} (V)* ¹	Ta = +25°C C _L = 50 pF			Ta = -40°C to +85°C C _L = 50 pF		Unit
			Min	Typ	Max	Min	Max	
Propagation delay Data to output	t _{PLH}	3.3	1.0	5.0	8.5	1.0	9.0	ns
		5.0	1.0	3.5	6.5	1.0	7.0	
Propagation delay Data to output	t _{PHL}	3.3	1.0	5.0	8.5	1.0	9.0	ns
		5.0	1.0	3.5	6.0	1.0	7.0	
Output enable time	t _{ZH}	3.3	1.0	7.0	11.5	1.0	12.5	ns
		5.0	1.0	5.0	8.5	1.0	9.0	
Output enable time	t _{ZL}	3.3	1.0	7.5	12.0	1.0	13.5	ns
		5.0	1.0	5.5	9.0	1.0	9.5	
Output disable time	t _{HZ}	3.3	1.0	6.5	12.0	1.0	12.5	ns
		5.0	1.0	5.5	9.0	1.0	10.0	
Output disable time	t _{LZ}	3.3	1.0	7.0	11.5	1.0	13.0	ns
		5.0	1.0	5.5	9.0	1.0	10.0	

Note: 1. Voltage Range 3.3 is 3.3 V ± 0.3 V
Voltage Range 5.0 is 5.0 V ± 0.5 V

AC Characteristics: HD74ACT245

Item	Symbol	V _{CC} (V)*1	Ta = +25°C C _L = 50 pF			Ta = -40°C to +85°C C _L = 50 pF		Unit
			Min	Typ	Max	Min	Max	
Propagation delay Data to output	t _{PLH}	5.0	1.0	4.0	7.5	1.0	8.0	ns
Propagation delay Data to output	t _{PHL}	5.0	1.0	4.0	8.0	1.0	9.0	ns
Output enable time	t _{ZH}	5.0	1.0	5.0	10.0	1.0	11.0	ns
Output enable time	t _{ZL}	5.0	1.0	5.5	10.0	1.0	12.0	ns
Output disable time	t _{HZ}	5.0	1.0	5.5	10.0	1.0	11.0	ns
Output disable time	t _{LZ}	5.0	1.0	5.0	10.0	1.0	11.0	ns

Note: 1. Voltage Range 5.0 is 5.0 V ± 0.5 V

Capacitance

Item	Symbol	Typ	Unit	Condition
Input capacitance	C _{IN}	4.5	pF	V _{CC} = 5.5 V
Input/output capacitance	C _{I/O}	15.0	pF	V _{CC} = 5.5 V
Power dissipation capacitance	C _{PD}	45.0	pF	V _{CC} = 5.0 V

Package Dimensions

As of January, 2003

Unit: mm

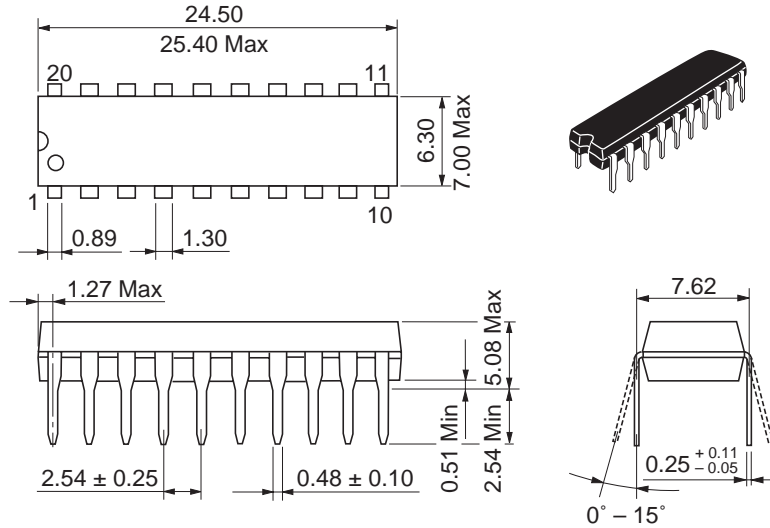

Package Code	DP-20N
JEDEC	—
JEITA	Conforms
Mass (reference value)	1.26 g

Unit: mm

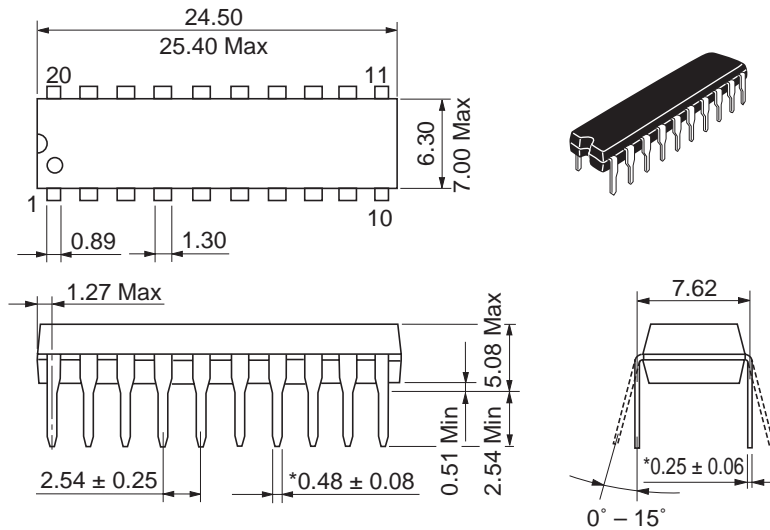

*Ni/Pd/AU Plating

Package Code	DP-20NEV
JEDEC	—
JEITA	Conforms
Mass (reference value)	1.26 g

HD74AC245/HD74ACT245

As of January, 2003

Unit: mm

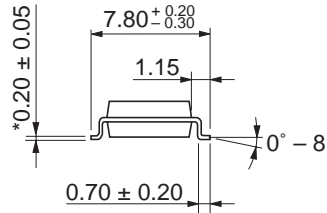
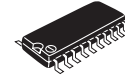
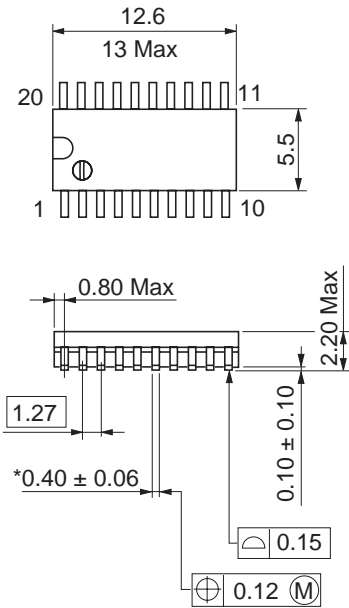

Package Code	FP-20DAV
JEDEC	—
JEITA	Conforms
Mass (reference value)	0.31 g

*Ni/Pd/Au plating

As of January, 2003

Unit: mm

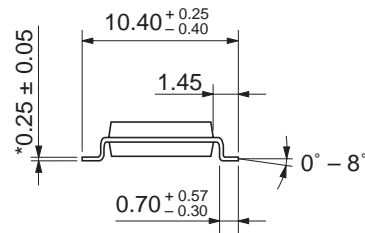
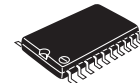
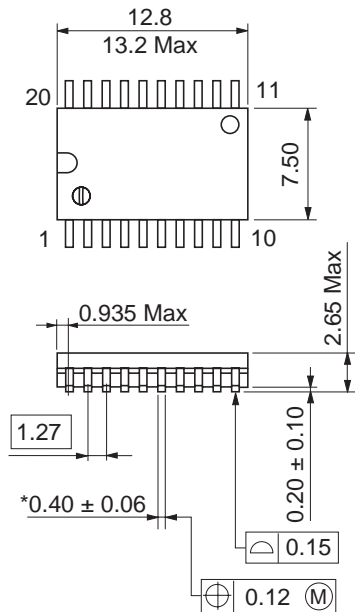

Package Code	FP-20DBV
JEDEC	Conforms
JEITA	—
Mass (reference value)	0.52 g

*Ni/Pd/Au plating

As of January, 2003
Unit: mm

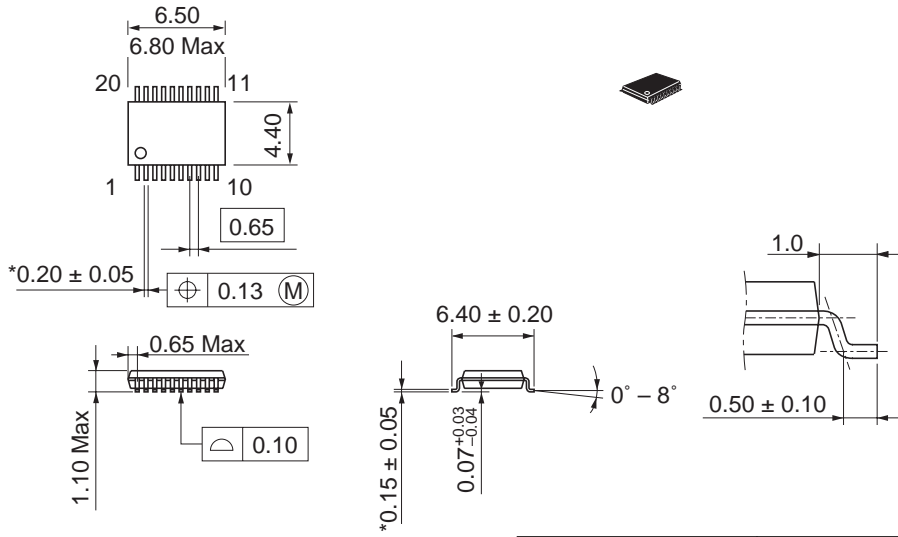

*Ni/Pd/Au plating

Package Code	TTP-20DAV
JEDEC	—
JEITA	—
Mass (reference value)	0.07 g

Renesas Technology Corp. Sales Strategic Planning Div. Nippon Bldg., 2-6-2, Ohte-machi, Chiyoda-ku, Tokyo 100-0004, Japan

Keep safety first in your circuit designs!

1. Renesas Technology Corp. puts the maximum effort into making semiconductor products better and more reliable, but there is always the possibility that trouble may occur with them. Trouble with semiconductors may lead to personal injury, fire or property damage. Remember to give due consideration to safety when making your circuit designs, with appropriate measures such as (i) placement of substitutive, auxiliary circuits, (ii) use of nonflammable material or (iii) prevention against any malfunction or mishap.

Notes regarding these materials

1. These materials are intended as a reference to assist our customers in the selection of the Renesas Technology Corp. product best suited to the customer's application; they do not convey any license under any intellectual property rights, or any other rights, belonging to Renesas Technology Corp. or a third party.
 2. Renesas Technology Corp. assumes no responsibility for any damage, or infringement of any third-party's rights, originating in the use of any product data, diagrams, charts, programs, algorithms, or circuit application examples contained in these materials.
 3. All information contained in these materials, including product data, diagrams, charts, programs and algorithms represents information on products at the time of publication of these materials, and are subject to change by Renesas Technology Corp. without notice due to product improvements or other reasons. It is therefore recommended that customers contact Renesas Technology Corp. or an authorized Renesas Technology Corp. product distributor for the latest product information before purchasing a product listed herein.
The information described here may contain technical inaccuracies or typographical errors.
Renesas Technology Corp. assumes no responsibility for any damage, liability, or other loss rising from these inaccuracies or errors.
Please also pay attention to information published by Renesas Technology Corp. by various means, including the Renesas Technology Corp. Semiconductor home page (<http://www.renesas.com>).
 4. When using any or all of the information contained in these materials, including product data, diagrams, charts, programs, and algorithms, please be sure to evaluate all information as a total system before making a final decision on the applicability of the information and products. Renesas Technology Corp. assumes no responsibility for any damage, liability or other loss resulting from the information contained herein.
 5. Renesas Technology Corp. semiconductors are not designed or manufactured for use in a device or system that is used under circumstances in which human life is potentially at stake. Please contact Renesas Technology Corp. or an authorized Renesas Technology Corp. product distributor when considering the use of a product contained herein for any specific purposes, such as apparatus or systems for transportation, vehicular, medical, aerospace, nuclear, or undersea repeater use.
 6. The prior written approval of Renesas Technology Corp. is necessary to reprint or reproduce in whole or in part these materials.
 7. If these products or technologies are subject to the Japanese export control restrictions, they must be exported under a license from the Japanese government and cannot be imported into a country other than the approved destination.
Any diversion or reexport contrary to the export control laws and regulations of Japan and/or the country of destination is prohibited.
 8. Please contact Renesas Technology Corp. for further details on these materials or the products contained therein.
-



RENESAS SALES OFFICES

<http://www.renesas.com>

Renesas Technology America, Inc.
450 Holger Way, San Jose, CA 95134-1368, U.S.A
Tel: <1> (408) 382-7500 Fax: <1> (408) 382-7501

Renesas Technology Europe Limited.
Dukes Meadow, Millboard Road, Bourne End, Buckinghamshire, SL8 5FH, United Kingdom
Tel: <44> (1628) 585 100, Fax: <44> (1628) 585 900

Renesas Technology Europe GmbH
Dornacher Str. 3, D-85622 Feldkirchen, Germany
Tel: <49> (89) 380 70 0, Fax: <49> (89) 929 30 11

Renesas Technology Hong Kong Ltd.
7/F., North Tower, World Finance Centre, Harbour City, Canton Road, Hong Kong
Tel: <852> 2265-6688, Fax: <852> 2375-6836

Renesas Technology Taiwan Co., Ltd.
FL 10, #99, Fu-Hsing N. Rd., Taipei, Taiwan
Tel: <886> (2) 2715-2888, Fax: <886> (2) 2713-2999

Renesas Technology (Shanghai) Co., Ltd.
26/F., Ruijin Building, No.205 Maoming Road (S), Shanghai 200020, China
Tel: <86> (21) 6472-1001, Fax: <86> (21) 6415-2952

Renesas Technology Singapore Pte. Ltd.
1, Harbour Front Avenue, #06-10, Keppel Bay Tower, Singapore 098632
Tel: <65> 6213-0200, Fax: <65> 6278-8001