

HD75159

Dual Differential Line Drivers With 3 State Outputs

HITACHI

ADE-205-589 (Z)

1st. Edition

Dec. 2000

Description

The HD75159 features dual differential line drivers with three state outputs, which satisfy the requirements of EIA(standard) RS-422A. Each driver has an output control. When the output control is low, the associated outputs are in a high impedance state. This permits many devices to be connected together on the same transmission line for party line applications.

Pin Arrangement

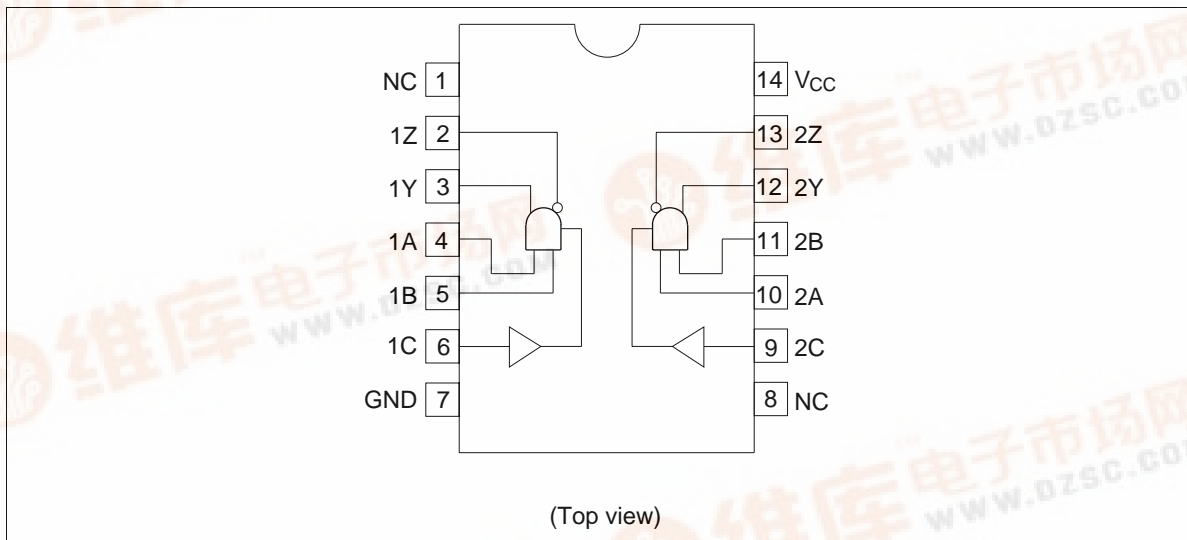

HD75159

Absolute Maximum Ratings

Item	Symbol	Rating	Unit
Supply Voltage	V_{CC}	7	V
Input Voltage	V_{IN}	5.5	V
Power Dissipation ($T_a = 25^\circ\text{C}$)	P_T^{*1}	DP	1150
		FP	785
Operating Temperature Range	T_{opr}	0 to 70	$^\circ\text{C}$
Storage Temperature Range	T_{stg}	-60 to +150	$^\circ\text{C}$

- Note: 1. The above data were taken by the ΔV_{BE} method, mounting on a glass epoxy board ($40 \times 40 \times 1.6$ mm) of 10 % wiring density.
 2. The absolute maximum ratings are values which must not individually be exceeded, and furthermore, no two of which may be realized at the same time.

Recommended Operating Conditions

Item	Symbol	Min	Typ	Max	Unit
Supply Voltage	V_{CC}	4.75	5.00	5.25	V
Output Current	I_{OH}	—	—	-40	mA
Output Current	I_{OL}	—	—	40	mA
Operating Temperature	T_{opr}	0	70	$^\circ\text{C}$	

Electrical Characteristics ($T_a = 0$ to 70°C)

Item	Symbol	Min	Typ* ¹	Max	Unit	Conditions
Input Voltage	V_{IH}	2	—	—	V	
	V_{IL}	—	—	0.8		
Input Clamp Voltage	V_{IK}	—	-0.9	-1.5	V	$V_{CC} = 4.75$ V, $I_I = -12$ mA
Output Voltage	V_{OH}	2.5	3.0	—	V	$V_{CC} = 4.75$ V, $V_{IL} = 0.8$ V $V_{IH} = 2$ V, $I_{OH} = -40$ mA
	V_{OL}	—	-0.25	0.5		$V_{CC} = 4.75$ V, $V_{IL} = 0.8$ V $V_{IH} = 2$ V, $I_{OL} = 40$ mA
Output Clamp Voltage	V_{OK}	—	-1.1	-1.5	V	$V_{CC} = 5.25$ V, $I_O = -40$ mA
Differential Output Voltage	V_{OD1}	—	3.5	$2 V_{OD2}$	V	$V_{CC} = 5.25$ V, $I_O = 0$
	V_{OD2}	—	2	3.0		$V_{CC} = 4.75$ V, $R_L = 100 \Omega^{*1}$
Change In Magnitude Of Differential Output Voltage* ²	$\Delta V_{OD} $	—	0.02	0.4	V	$V_{CC} = 4.75$ V, $R_L = 100 \Omega^{*1}$
Common-mode Output Voltage* ³	V_{OC}	—	1.8	3	V	$V_{CC} = 5.25$ V, $R_L = 100 \Omega^{*1}$
		—	1.5	3		$V_{CC} = 4.75$ V, $R_L = 100 \Omega^{*1}$

Electrical Characteristics (Ta = 0 to 70°C) (cont)

Item	Symbol	Min	Typ*1	Max	Unit	Conditions
Change In Magnitude Of Differential Output Voltage*2	$\Delta V_{oc} $	—	0.01	0.4	V	V _{cc} = 4.75 V or 5.25 V
Output Current With Power Off	I _o	—	0.1	100	μA	V _{cc} = 0 V, V _o = 6 V
		—	-0.1	-100		V _{cc} = 0 V, V _o = -0.25 V
		—	—	±100		V _{cc} = 0 V, V _o = -0.25 V to 6 V
Off State (High Impedance State) Output Current	I _{oz}	—	—	±10	μA	V _{cc} = 5.25 V Output Control 0.8 V Ta = 25°C, V _o = 0 to V _{cc}
		—	—	-20		V _{cc} = 5.25 V Output Control 0.8 V, Input Ta=70°C, V _o = 0 V
		—	—	±20		V _{cc} = 5.25 V Output Control 0.8 V, Input Ta=70°C, V _o = 0.4 V
		—	—	±20		V _{cc} = 5.25 V Output Control 0.8 V, Input Ta=70°C, V _o = 2.4 V
		—	—	20		V _{cc} = 5.25 V Output Control 0.8 V, Input Ta=70°C, V _o = V _{cc}
Input Current	I _i	—	—	1	mA	V _{cc} = 5.25 V, V _i = 5.5 V
	I _{iH}	—	—	40	μA	V _{cc} = 5.25 V, V _i = 2.4 V
	I _{iL}	—	-1	-1.6	mA	V _{cc} = 5.25 V, V _i = 0.4 V
Short Circuit Output Current*4	I _{os}	-40	-90	-150	mA	V _{cc} = 5.25 V
Supply Current	I _{cc}	—	47	65	mA	V _{cc} = 5.25 V No Load, Inputs Grounded Ta = 25°C

- Notes: 1. All typical values are at V_{cc} = 5 V, Ta = 25°C.
 2. $\Delta |V_{ob}|$ and $\Delta |V_{oc}|$ are the changes in magnitudes of V_{ob} and V_{oc}, respectively, that occur when the input is changed from a high level to a low level.
 3. In EIA standard RS-422A, V_{oc}, which is the average of the two output voltages with respect to ground, is called output offset voltage, V_{os}.
 4. Only one output should be shorted at a time, and duration of the short circuit should not exceed one second.

HD75159

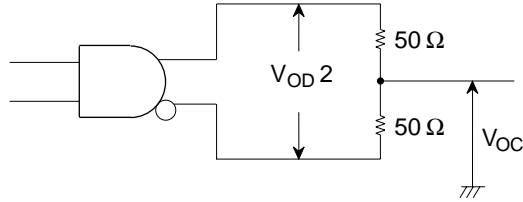

Note: 1. Differential and common mode output voltages.

Switching Characteristics ($V_{CC} = 5.0 \text{ V}$, $T_a = 25^\circ\text{C}$)

Item	Symbol	Min	Typ	Max	Unit	Test Circuit	Conditions
Propagation Delay Time	t_{PLH}	—	16	25	ns	1	$C_L = 30 \text{ pF}$, $R_L = 100 \Omega$
	t_{PHL}	—	11	20		Termination A	
	t_{PLH}	—	13	20		1	$C_L = 15 \text{ pF}$
	t_{PHL}	—	9	15		Termination B	
Transition Time	t_{TLH}	—	4	20		1	$C_L = 30 \text{ pF}$, $R_L = 100 \Omega$
	t_{THL}	—	4	20		Termination A	
Output Enable Time	t_{ZH}	—	7	20		2	$C_L = 30 \text{ pF}$, $R_L = 180 \Omega$
	t_{ZL}	—	14	40		3	$C_L = 30 \text{ pF}$, $R_L = 250 \Omega$
Output Disable Time	t_{HZ}	—	10	30		2	$C_L = 30 \text{ pF}$, $R_L = 180 \Omega$
	t_{LZ}	—	17	35		3	$C_L = 30 \text{ pF}$, $R_L = 250 \Omega$
Overshoot Output Factor		—	—	10	%	1 Termination C	$R_L = 100 \Omega$

Switching Time Test Method

Test Circuit

1. t_{PLH} , t_{PHL} , t_{TLB} , t_{THL} , and overshoot factor

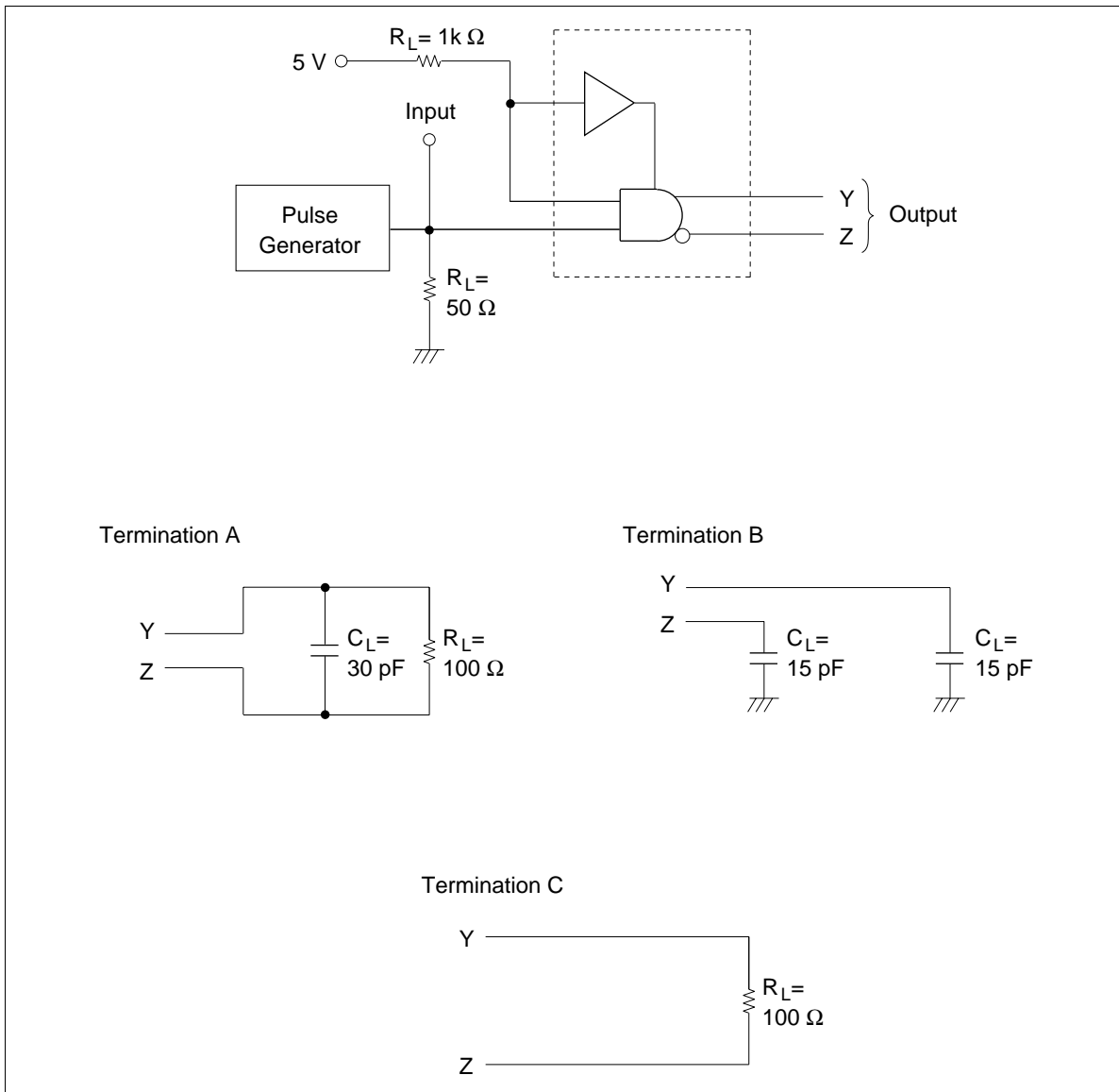

HD75159

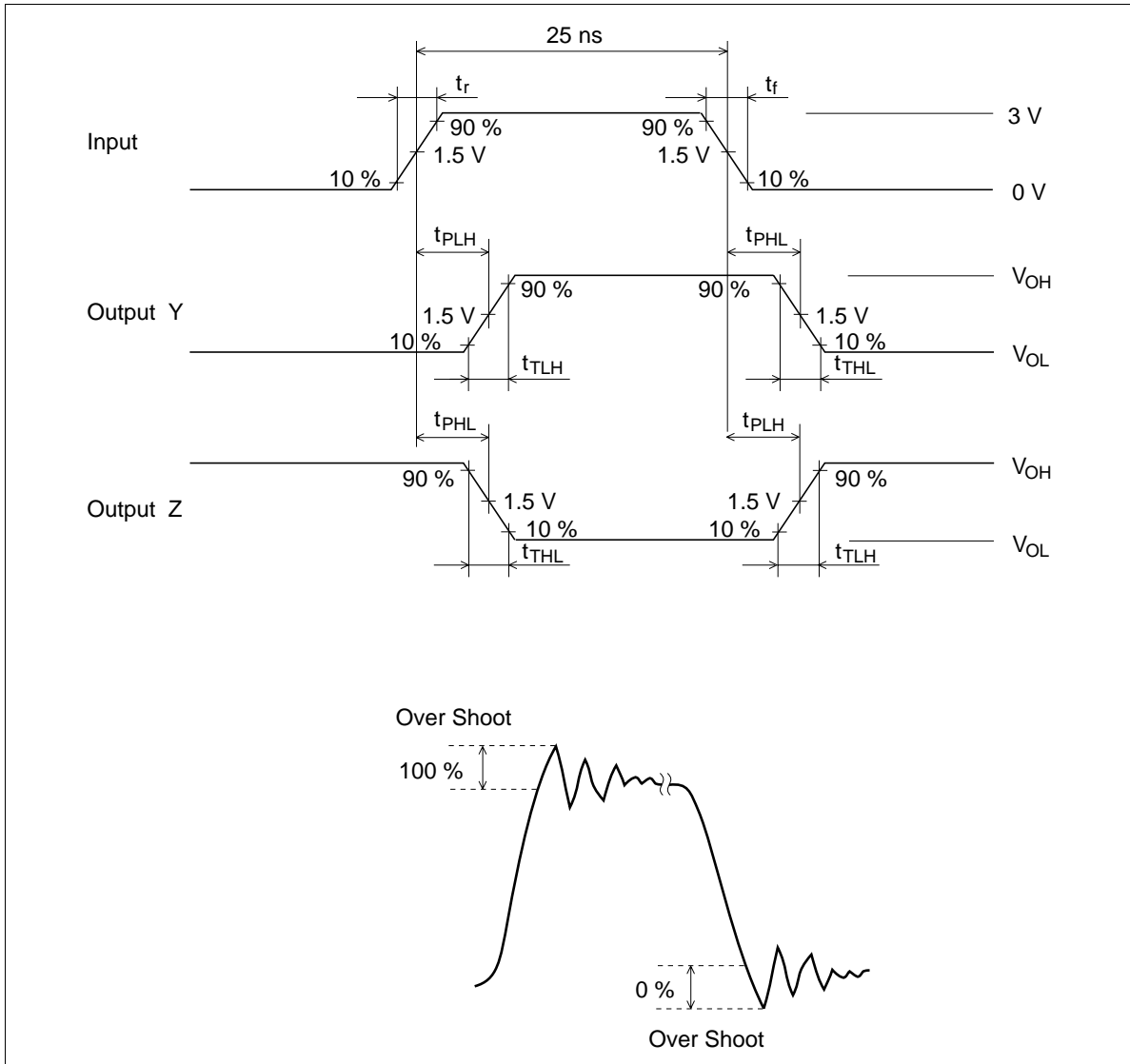

2. t_{ZH} , t_{HZ}

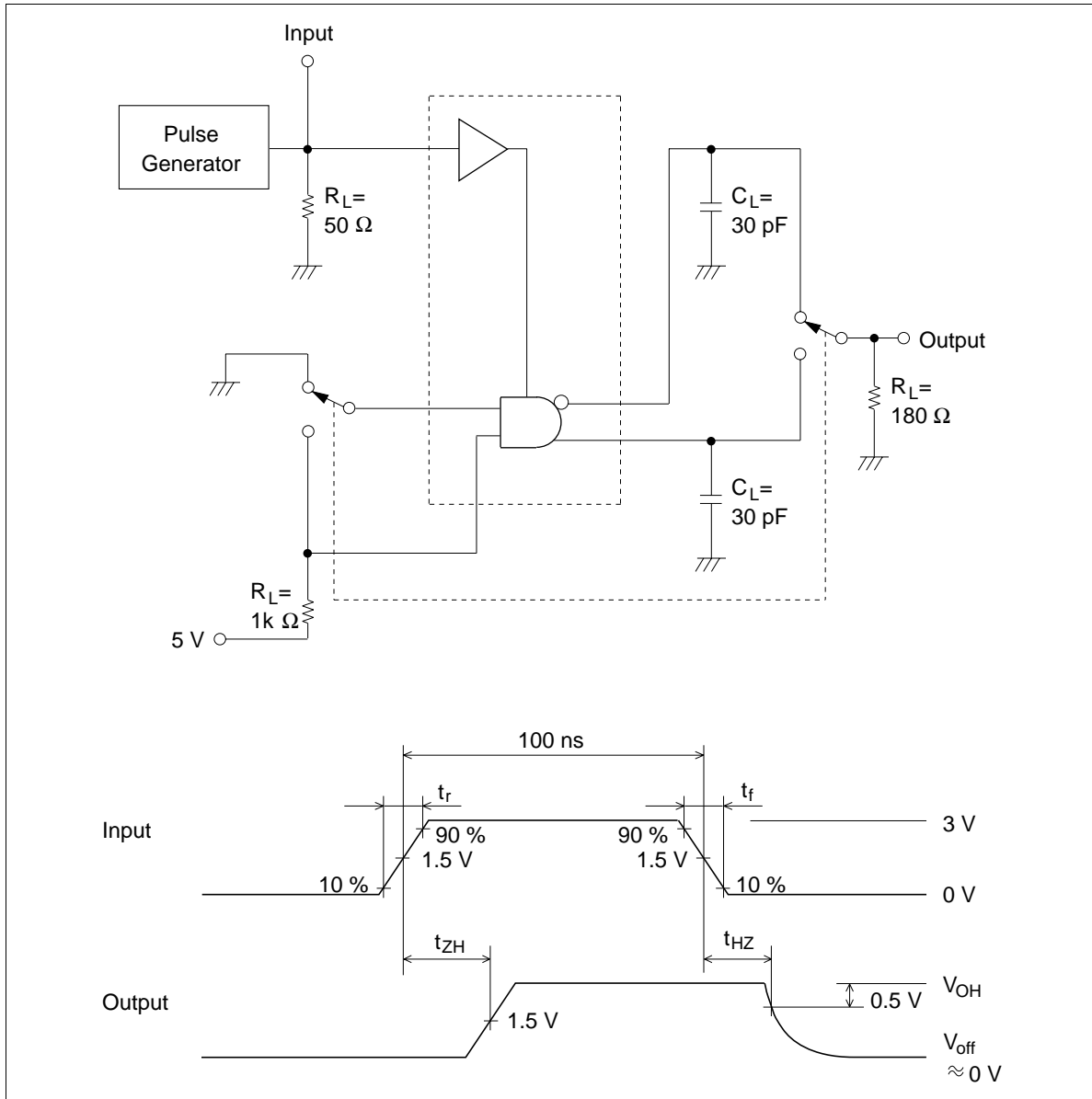

HD75159

3. t_{zL} , t_{LZ}

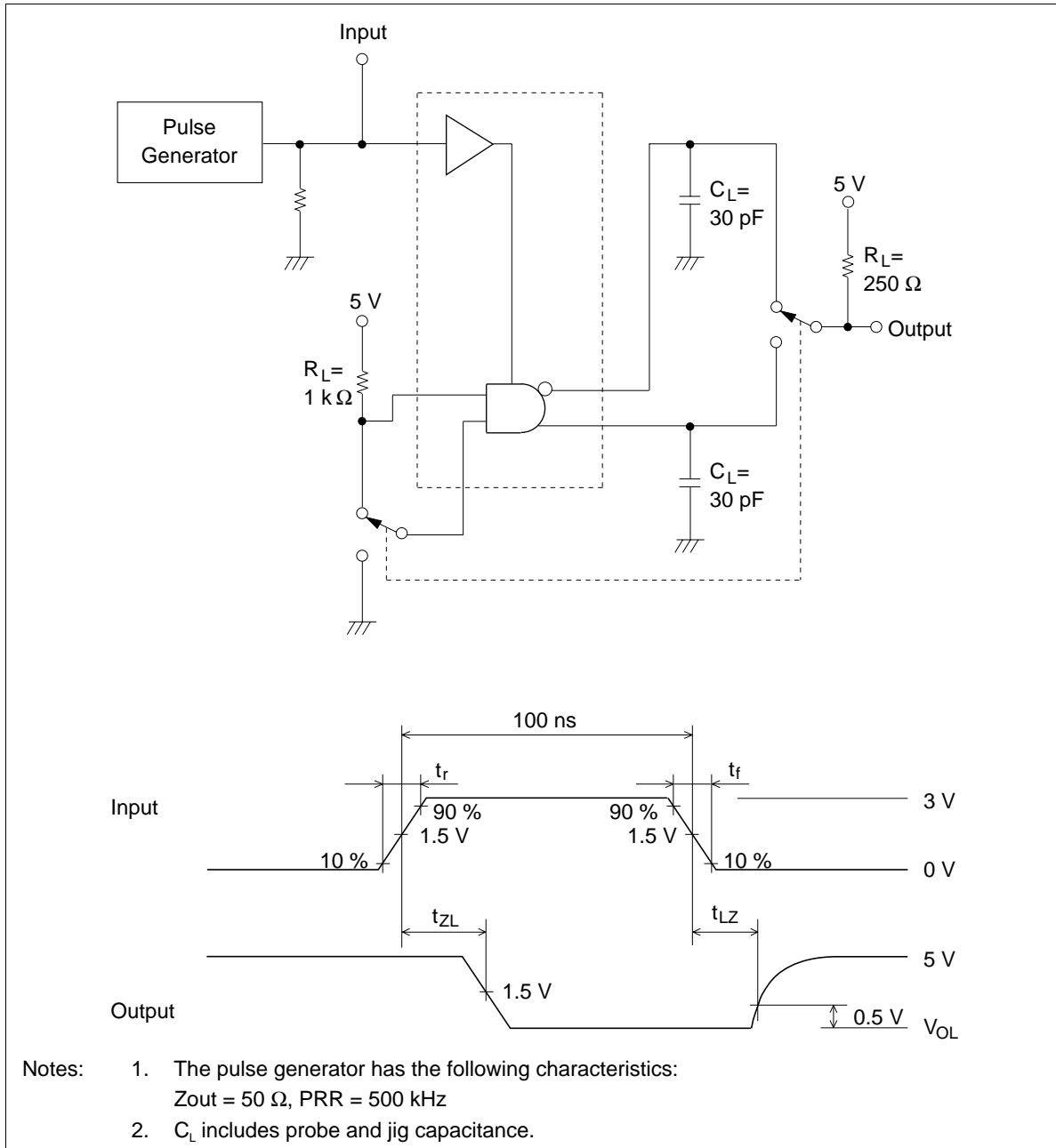

Package Dimensions

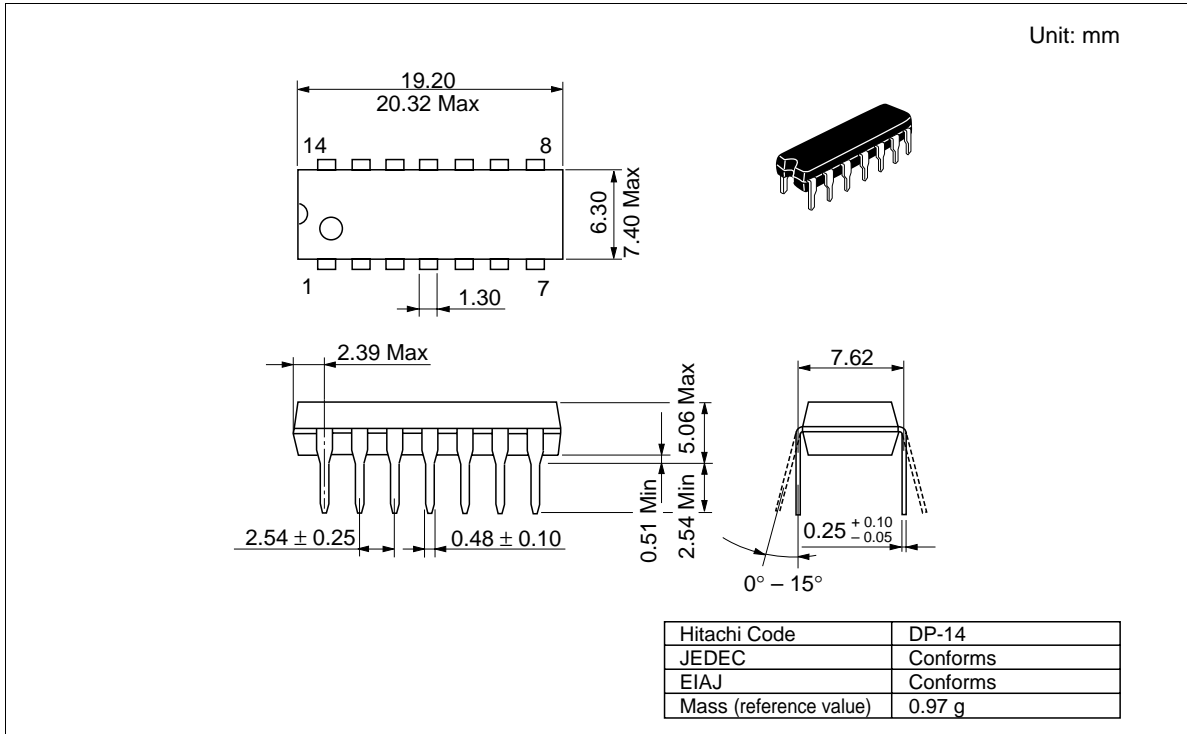

Cautions

1. Hitachi neither warrants nor grants licenses of any rights of Hitachi's or any third party's patent, copyright, trademark, or other intellectual property rights for information contained in this document. Hitachi bears no responsibility for problems that may arise with third party's rights, including intellectual property rights, in connection with use of the information contained in this document.
2. Products and product specifications may be subject to change without notice. Confirm that you have received the latest product standards or specifications before final design, purchase or use.
3. Hitachi makes every attempt to ensure that its products are of high quality and reliability. However, contact Hitachi's sales office before using the product in an application that demands especially high quality and reliability or where its failure or malfunction may directly threaten human life or cause risk of bodily injury, such as aerospace, aeronautics, nuclear power, combustion control, transportation, traffic, safety equipment or medical equipment for life support.
4. Design your application so that the product is used within the ranges guaranteed by Hitachi particularly for maximum rating, operating supply voltage range, heat radiation characteristics, installation conditions and other characteristics. Hitachi bears no responsibility for failure or damage when used beyond the guaranteed ranges. Even within the guaranteed ranges, consider normally foreseeable failure rates or failure modes in semiconductor devices and employ systemic measures such as fail-safes, so that the equipment incorporating Hitachi product does not cause bodily injury, fire or other consequential damage due to operation of the Hitachi product.
5. This product is not designed to be radiation resistant.
6. No one is permitted to reproduce or duplicate, in any form, the whole or part of this document without written approval from Hitachi.
7. Contact Hitachi's sales office for any questions regarding this document or Hitachi semiconductor products.

HITACHI

Hitachi, Ltd.

Semiconductor & Integrated Circuits.
Nippon Bldg., 2-6-2, Ohte-machi, Chiyoda-ku, Tokyo 100-0004, Japan
Tel: Tokyo (03) 3270-2111 Fax: (03) 3270-5109

URL	NorthAmerica	: http://semiconductor.hitachi.com/
	Europe	: http://www.hitachi-eu.com/hel/ecg
	Asia	: http://sicapac.hitachi-asia.com
	Japan	: http://www.hitachi.co.jp/Sicd/indx.htm

For further information write to:

Hitachi Semiconductor
(America) Inc.
179 East Tasman Drive,
San Jose, CA 95134
Tel: <1>(408) 433-1990
Fax: <1>(408) 433-0223

Hitachi Europe GmbH
Electronic Components Group
Dornacher StraÙe 3
D-85622 Feldkirchen, Munich
Germany
Tel: <49> (89) 9 9180-0
Fax: <49> (89) 9 29 30 00

Hitachi Europe Ltd.
Electronic Components Group.
Whitebrook Park
Lower Cookham Road
Maidenhead
Berkshire SL6 8YA, United Kingdom
Tel: <44> (1628) 585000
Fax: <44> (1628) 585160

Hitachi Asia Ltd.
Hitachi Tower
16 Collyer Quay #20-00,
Singapore 049318
Tel : <65>-538-6533/538-8577
Fax : <65>-538-6933/538-3877
URL : <http://www.hitachi.com.sg>

Hitachi Asia Ltd.
(Taipei Branch Office)
4/F, No. 167, Tun Hwa North Road,
Hung-Kuo Building,
Taipei (105), Taiwan
Tel : <886>-(2)-2718-3666
Fax : <886>-(2)-2718-8180
Telex : 23222 HAS-TP
URL : <http://www.hitachi.com.tw>

Hitachi Asia (Hong Kong) Ltd.
Group III (Electronic Components)
7/F., North Tower,
World Finance Centre,
Harbour City, Canton Road
Tsim Sha Tsui, Kowloon,
Hong Kong
Tel : <852>-(2)-735-9218
Fax : <852>-(2)-730-0281
URL : <http://www.hitachi.com.hk>

Copyright © Hitachi, Ltd., 2000. All rights reserved. Printed in Japan.
Colophon 2.0