

Agilent HEDR-8130 Reflective Optical Surface Mount Encoders Data Sheet

Description

The HEDR-8130 encoder uses reflective technology to sense rotary or linear position. This sensor consists of an LED light source and a photodetector IC in a single S0-8 surface mount package. When used with a reflective codewheel or codestrip, this device can sense rotary or linear position.

The reflective surface mount optical encoder provides two square wave outputs in quadrature for count and direction information. These TTL-compatible outputs correspond to the alternating reflective/non-reflective pattern of the codewheel or codestrip.

The HEDR-8130 can be used with a codewheel or codestrip with 150 lines per inch (5.91 lines per mm).

Applications

The HEDR-8130 provides two channel motion sensing at a very low cost, making it ideal for high volume applications. Its small size and surface mount capability make it ideal for printers, copiers, card readers, and consumer product applications.

Note: Agilent Technologies encoders are not recommended for use in safety critical applications. Eg. ABS braking systems, power steering, life support systems and critical care medical equipment. Please contact sales representative if more clarification is needed.

Theory of Operation

The HEDR-8130 combines an emitter and a detector in a single surface mount S0-8 package. When used with a codewheel or codestrip, the reflective sensors translate rotary or linear motion into a two-channel digital output.

The HEDR-8130 has three key parts: a single Light Emitting Diode (LED) light source, a photodetector IC with a set of uniquely configured photodiodes, and a pair of lenses molded into the package. The lens over the LED focuses light onto the codewheel or codestrip. Light is either reflected or not reflected back to the lens over the photodetector IC.

Features

- Reflective technology
- Surface mount S0-8 package
- Two channel quadrature outputs for direction sensing
- 3.3 V input and output
- 150 lpi (5.91 lines/mm)

As the codewheel rotates, or codestrip passes by, an alternating pattern of light and dark corresponding to the pattern of the codewheel falls upon the photodiodes. This light is used to produce internal signals A and A-bar, and B and B-bar. As part of this "push-pull" detector system, these signals are fed through comparators to produce the final output for channels A and B.

Definitions

(Note: Refer to the Appendix for Signals Diagram.)

Count (N) = The number of bar and window pairs or Counts Per Revolution (CPR) of the code-wheel, or the number of Lines Per Inch of the codestrip (LPI).

1 Shaft Rotation
= 360 mechanical degrees
= N cycles
1 cycles (c)
= 360 electrical degrees ($^{\circ}e$)
= 1 bar and window pair

Pulse Width (P): The number of electrical degrees that an output is high during one cycle. This value is nominally $180^{\circ}e$ or $1/2$ cycle.

Pulse Width Error (ΔP): The deviation, in electrical degrees, of the pulse width from its ideal value of $180^{\circ}e$.

State Width (S): The number of electrical degrees between a transition in the output of channel A

and the neighboring transition in the output of channel B. There are 4 states per cycle, each nominally $90^{\circ}e$.

State Width Error (ΔS): The deviation, in electrical degrees, of each state width from its ideal value of $90^{\circ}e$.

Phase (ϕ): The number of electrical degrees between the center of the high state of channel A and the center of the high state of channel B.

This value is nominally $90^{\circ}e$ for quadrature output.

Phase Error ($\Delta\phi$): the deviation of the phase from its ideal value of $90^{\circ}e$.

Direction of Rotation: When the codewheel or codestrip moves in the direction from pin 1 to pin 4, as viewed when looking down on the lenses, channel B will lead channel A. If the codewheel or codestrip moves in the opposite direction, channel A will lead channel B.

Optical Radius (Rop): For rotary motion, the distance from the codewheel's center of rotation to the center line connecting the two lenses of the encoder.

Gap (G): The distance from the top of the package to the surface of the reflective codewheel or codestrip.

Specular Reflectance (Rf): A measure of a surface's reflective finish. This is quantified by the amount of light reflected when hit with an incident beam. A device called a scatterometer is used to quantify specular reflectance on a percent scale. (Contact factory for more information.)

Radial and Tangential Misalignment Error E_R , E_T): For rotary motion, mechanical misalignment in the radial and tangential directions relative to the codewheel.

Angular Misalignment Error (E_A): Angular misalignment of the sensor in relation to the tangential direction. This applies for both rotary and linear motion.

Absolute Maximum Ratings

Parameter	Symbol	Min.	Max.	Units	Notes
Storage Temperature	T_S	-40	85	$^{\circ}C$	
Operating Temperature	T_A	-10	85	$^{\circ}C$	
Supply Voltage	V_{CC}	-0.5	5	V	
Output Voltage	V_O	-0.5	V_{CC}	V	
Output Current per Channel	I_O	-0.2	9	mA	

Recommended Operating Conditions

Parameter	Symbol	Min.	Typ.	Max.	Units	Notes
Temperature	T	-10	25	85	°C	
Supply Voltage	V _{CC}	3	3.3	3.5	V	Ripple < 100 mV p-p
LED Current	I _{LED}	13	16	18	mA	See "Current Limiting Resistor for LED"
Load Capacitance	C _L			100	pF	
Pull-Up Resistor	R _L		none		KΩ	Recommend no pull-up. Device has integrated 2.5 KΩ on outputs.
Count Frequency				15	kHz	(Velocity (rpm) x N)/60
Radial Misalignment	E _R			± 0.38 (± 0.015)	mm (in.)	
Tangential Misalignment	E _T			± 0.38 (± 0.015)	mm (in.)	
Angular Misalignment	E _A		0.0	± 1.5	deg.	
Codewheel or Codestrip Gap	G	0.2	1.4	2.00	mm	1.4 mm is the recommended gap but the unit can operate from 0.2 to 2 mm with no problem
Codewheel or Codestrip Specular Reflectance	R _f	60%				As other rose products, eg., HEDR-8100 series
Codewheel/Codestrip Tilt	C _T		0	1	deg.	
Codewheel/Codestrip Resolution	LPmm (LPI)		5.91 (150)		lines/mm (lines/in.)	HEDR-8130 is 150 lpi

Encoding Characteristics

Encoding Characteristics over Recommended Operating Conditions and Mounting Conditions.

Parameter	Symbol	Typical	Max.	Units	Notes
Pulse Width Error	P	16	75	°e	HEDR-8130
Phase Error	φ	10	60	°e	HEDR-8130
State Error	S	30	75	°e	HEDR-8130

Electrical Characteristics

Electrical Characteristics over Recommended Operating Conditions. Typical Values at 25°C.

Parameter	Symbol	Min.	Typ.	Max.	Units	Notes
Supply Current	I_{CC}		3	5	mA	
High Level Output Voltage	V_{OH}	2.4		3.3	V	$I_{OH} = -140 \mu A$
Low Level Output Voltage	V_{OL}			0.4	V	$I_{OL} = 8 \text{ mA}$
Rise Time	t_r		150	200	ns	$C_L = 25 \text{ pF}$ $R_L = 2.7 \text{ K}\Omega$
Fall Time	t_f		50	60	ns	

Current Limiting Resistor for LED

A resistor to limit current to the LED is required. The recommended value is $110 \Omega (\pm 10\%)$ and should be placed in series between the 3.3 V supply and pin 8 of the device (V_{LED}). This will result in an LED current of approximately 16 mA.

Recommended Codewheel and Codestrip Characteristics

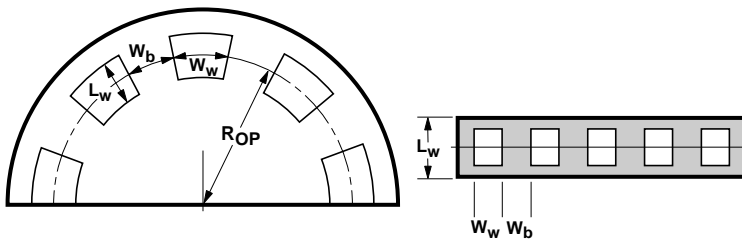
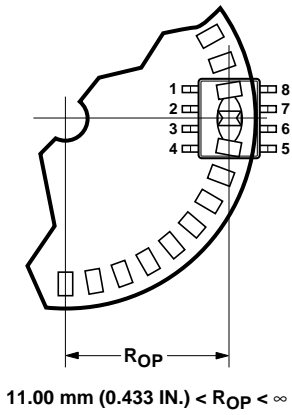

Table 1.

Parameter	Symbol	Min.	Max.	Units	Notes
Window/Bar Ratio	W_w/W_b	0.9	1.1		
Specular Reflectance	R_f	60	85		Reflective Bars
		—	10		Non-reflective Bars
Line Density	LPmm (LPI)		5.91 (150)	lines/mm (lines/inch)	
Window Length	L_w	1.80 (0.071)	2.31 (0.091)	mm (inches)	mm (inches)

Mounting Conditions



IR Soldering Conditions

The following recommended IR soldering profile meets the specifications of the Electronic Industries Association of Japan (EIAJ):

1. $150 \pm 10^\circ\text{C}$ for 90 ± 30 seconds
2. Greater than 200°C for 30 ± 10 seconds
3. $230 \pm 5^\circ\text{C}$ for 10 ± 1 seconds

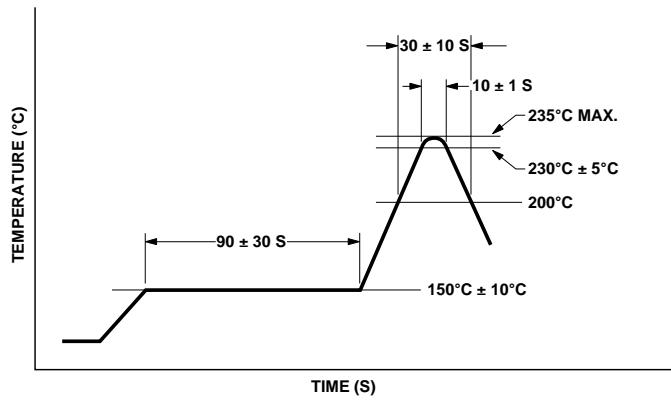

Ordering Information

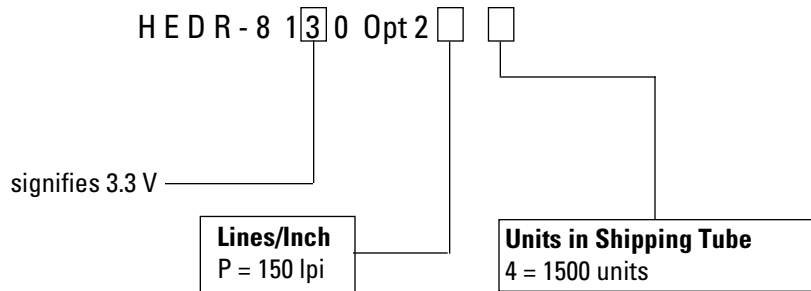

Outline Drawing

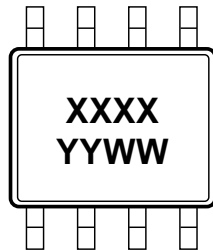
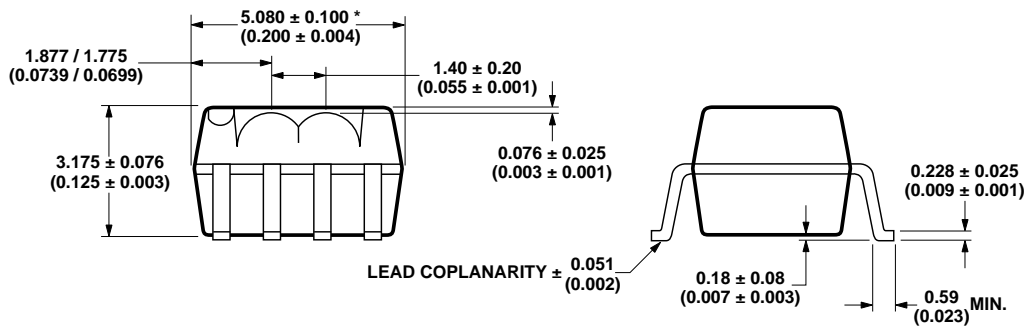
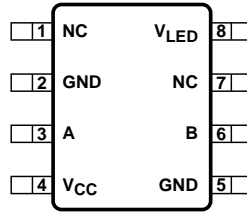
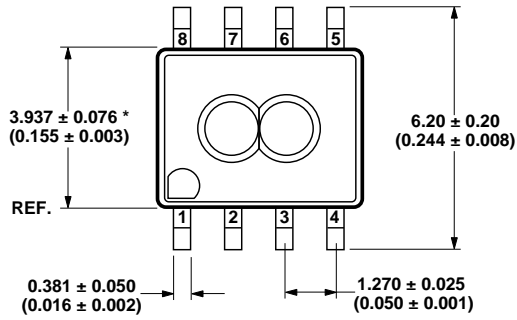

NOTES:

- DO NOT INCLUDE FLASH IN DIMENSIONS MARKED WITH AN *.
- DEVICE MARKING ORIENTATION IS AS SHOWN.
DATE CODE IS YEAR/WORKWEEK (YYWW).
PART NUMBER IS XXXX.
- DIMENSIONS IN MILLIMETERS (INCHES).

Appendix

Note: For Definitions in page 2 and Electrical Characteristics in page 3.

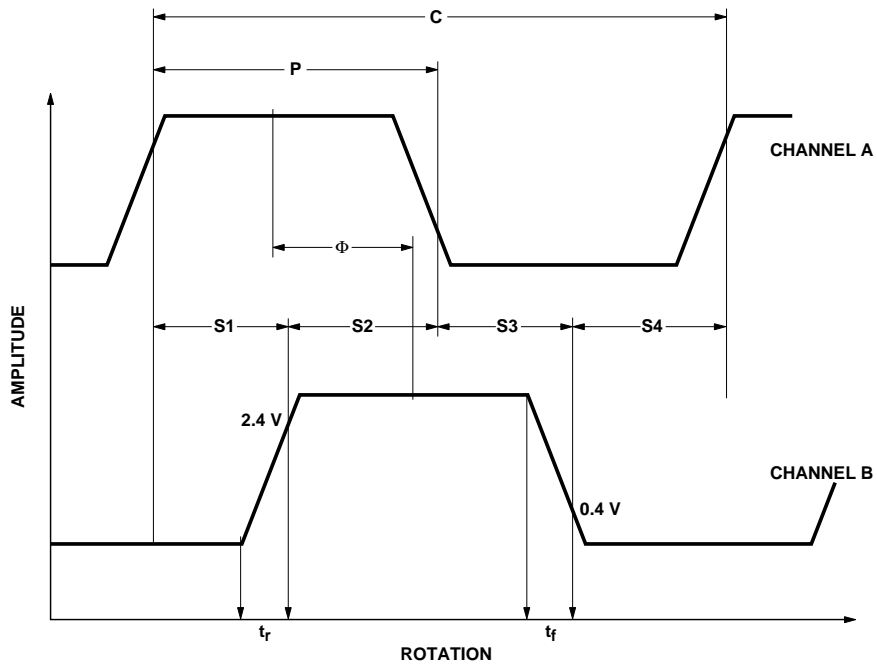

www.agilent.com/semiconductors

For product information and a complete list of distributors, please go to our web site.

For technical assistance call:

Americas/Canada: +1 (800) 235-0312 or (408) 654-8675

Europe: +49 (0) 6441 92460

China: 10800 650 0017

Hong Kong: (+65) 6271 2451

India, Australia, New Zealand: (+65) 6271 2394

Japan: (+81 3) 3335-8152(Domestic/International), or 0120-61-1280(Domestic Only)

Korea: (+65) 6271 2194

Malaysia, Singapore: (+65) 6271 2054

Taiwan: (+65) 6271 2654

Data subject to change.

Copyright © 2002 Agilent Technologies, Inc.

May 3, 2002

5988-5014EN



Agilent Technologies