



HI20203

8-Bit, 160 MSPS, Ultra High-Speed D/A Converter

August 2000

**OBSOLETE PRODUCT
FOR A POSSIBLE SUBSTITUTE PRODUCT**
contact our Technical Support Center at
1-888-INTERSIL or www.intersil.com/tsc

Features

- Throughput Rate 160MHz
- 8-Bit (HI20203) Resolution
- Differential Linearity Error 0.5 LSB
- Low Glitch Noise
- Analog Multiplying Function
- Low Power Consumption420mW
- Evaluation Board Available
- Direct Replacement for the Sony CX20201-3, CX20202-3

Applications

- Wireless Communications
- Signal Reconstruction
- Direct Digital Synthesis
- High Definition Video Systems
- Digital Measurement Systems
- Radar

Description

The HI20203 is an 8-bit, 160MHz ultra high speed D/A converter. The converter is based on an R2R switched current source architecture that includes an input data register with a complement feature and is Emitter Coupled Logic (ECL) compatible.

The HI20203 is an 8-bit accurate D/A with a linearity error of 0.5 LSB.

For 10-bit resolution, please refer to the HI20201 data sheet.

Part Number Information

PART NUMBER	TEMP. RANGE (°C)	PACKAGE	PKG. NO.
HI20203JCB	-20 to 75	28 Ld SOIC	M28.3A-S

Pinout

HI20203
(PDIP, SOIC)
TOP VIEW

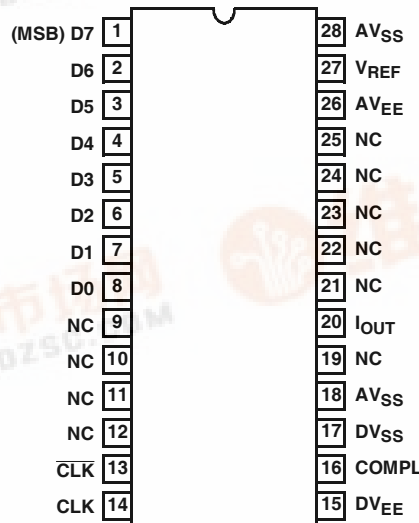

HI20203

Typical Application Circuit

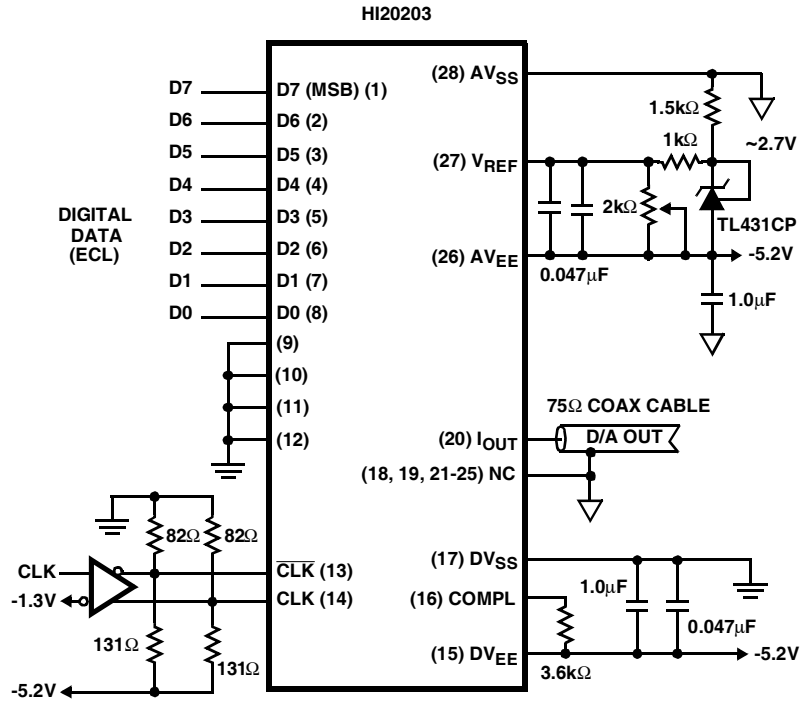

Functional Block Diagram

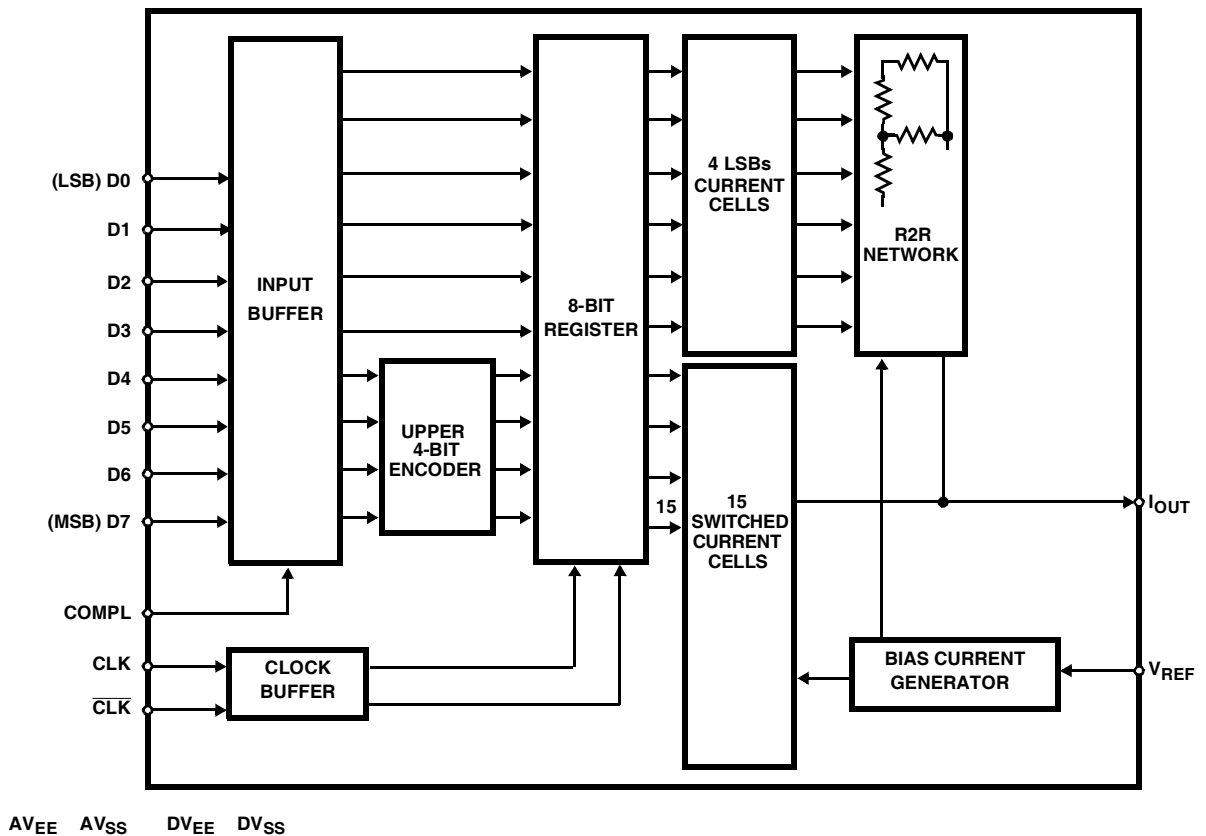

HI20203

Absolute Maximum Ratings $T_A = 25^\circ\text{C}$

Digital Supply Voltage DV_{EE} to DV_{SS}	-7.0V
Analog Supply Voltage AV_{DD} to AV_{SS}	-7.0V
Digital Input Voltage	+0.3 to DV_{EE} V
Reference Input Voltage	+0.3 to AV_{EE} V
Output Current	20mA

Thermal Information

Thermal Resistance (Typical, Note 5)	θ_{JA} ($^\circ\text{C}/\text{W}$)
SOIC Package	67
PDIP Package	58
Maximum Junction Temperature	150 $^\circ\text{C}$
Maximum Storage Temperature Range	-65 $^\circ\text{C}$ to 150 $^\circ\text{C}$
Maximum Lead Temperature (Soldering 10s)	300 $^\circ\text{C}$ (SOIC - Lead Tips Only)

Operating Conditions

Supply Voltage	
AV_{EE} , DV_{EE}	-4.75V to -5.45V
$AV_{EE} - DV_{EE}$	-0.05V to +0.05V
Digital Input Voltage	
V_{IH}	-1.0V to -0.7V
V_{IL}	-1.9V to -1.6V

Reference Input Voltage, V_{REE}	$V_{EE} + 0.5\text{V}$ to $V_{EE} + 1.4\text{V}$
Load Resistance, R_L	Above 75 Ω
Output Voltage, $V_{O(FS)}$	0.8V to 1.2V
Temperature Range	-20 $^\circ\text{C}$ to 75 $^\circ\text{C}$

CAUTION: Stresses above those listed in "Absolute Maximum Ratings" may cause permanent damage to the device. This is a stress only rating and operation of the device at these or any other conditions above those indicated in the operational sections of this specification is not implied.

NOTE:

- θ_{JA} is measured with the component mounted on an evaluation PC board in free air.

Electrical Specifications $AV_{EE} = -5.2\text{V}$, $DV_{EE} = -5.2\text{V}$, $AGND = 0\text{V}$, $DGND = 0\text{V}$, $R_L = \infty$, $V_{OUT} = -1\text{V}$, $T_A = 25^\circ\text{C}$

PARAMETER	TEST CONDITION	HI20203JCB/JCP			UNITS
		MIN	TYP	MAX	
SYSTEM PERFORMANCE					
Resolution		8	-	-	Bits
Integral Linearity Error, INL	$f_S = 160\text{MHz}$ (End Point)	-	-	± 0.5	LSB
Differential Linearity Error, DNL	$f_S = 160\text{MHz}$	-	-	± 0.50	LSB
Offset Error, V_{OS} (Adjustable to Zero)	(Note 3)	-	1.8	-	LSB
Full Scale Error, FSE (Adjustable to Zero)	(Note 3)	-	-	± 26	LSB
Full Scale Output Current, I_{FS}		-	-	20	mA
DYNAMIC CHARACTERISTICS					
Throughput Rate	See Figure 11	160	-	-	MHz
Glitch Energy, GE	$R_{OUT} = 75\Omega$	-	15	-	pV/s
REFERENCE INPUT					
Voltage Reference Input Range	With respect to AV_{EE}	+0.5	-	+1.4	V
Reference Input Current	$V_{REF} = -4.58\text{V}$	-0.1	-0.4	-3.0	μA
Voltage Reference to Output Small Signal Bandwidth	-3dB point $1V_{p-p}$ Input	-	14.0	-	MHz
Output Rise Time, t_r	$R_{LOAD} = 75\Omega$	-	1.5	-	ns
Output Fall Time, t_f	$R_{LOAD} = 75\Omega$	-	1.5	-	ns
DIGITAL INPUTS					
Input Logic High Voltage, V_{IH}	(Note 2)	-1.0	-0.89		V
Input Logic Low Voltage, V_{IL}	(Note 2)		-1.75	-1.6	V

HI20203

Electrical Specifications $AV_{EE} = -5.2V, DV_{EE} = -5.2V, AGND = 0V, DGND = 0V, R_L = \infty, V_{OUT} = -1V, T_A = 25^\circ C$ (Continued)

PARAMETER	TEST CONDITION	HI20203JCB/JCP			UNITS
		MIN	TYP	MAX	
Input Logic Current, I_{IL}, I_{IH} (For D9 thru D6, COMPL)	$V_{IH} = -0.89V, V_{IL} = -1.75V$ (Note 2)	0.1	1.5	6.0	μA
Input Logic Current, I_{IL}, I_{IH} (For D5 thru D0)	$V_{IH} = -0.89V, V_{IL} = -1.75V$ (Note 2)	0.1	0.75	3.0	μA
TIMING CHARACTERISTICS					
Data Setup Time, t_{SU}	See Figure 11	5	-	-	ns
Data Hold Time, t_{HLD}	See Figure 11	1	-	-	ns
Propagation Delay Time, t_{PD}	See Figure 11	-	3.8	-	ns
Settling Time, t_{SET} (to $1/2$ LSB)	See Figure 11	-	4.3	-	ns
POWER SUPPLY CHARACTERISTICS					
I_{EE}		-60	-75	-90	mA
Power Dissipation	75 Ω load	-	420	470	mW

NOTES:

2. Parameter guaranteed by design or characterization and not production tested.
3. Excludes error due to reference drift.
4. Electrical specifications guaranteed only under the stated operating conditions.

Timing Diagram

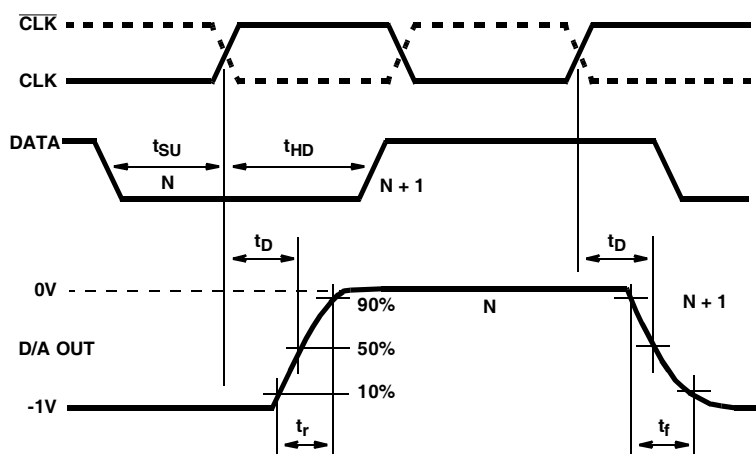

FIGURE 1. LADDER SETTLING TIME FULL POWER BANDWIDTH (LS)

Typical Performance Curves

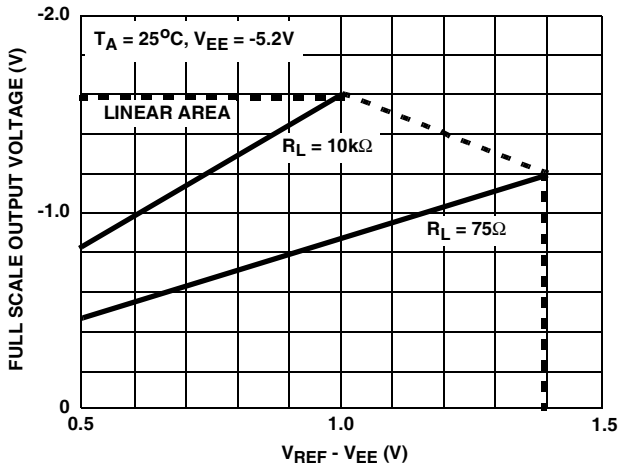

FIGURE 2. $V_{O(FS)}$ RATIO vs $(V_{REF} - V_{EE})$

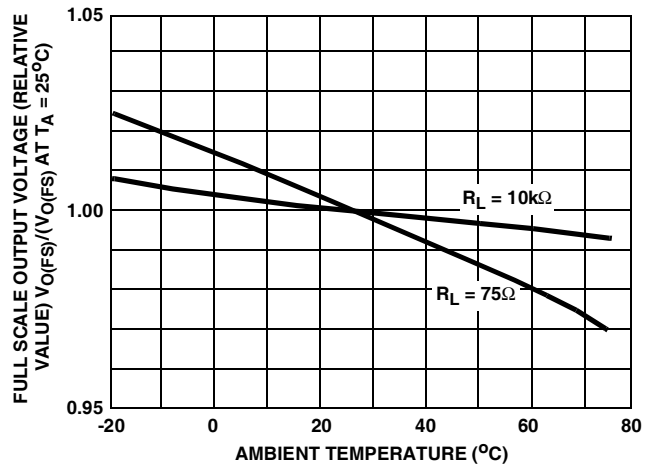

FIGURE 3. FULL SCALE OUTPUT VOLTAGE vs AMBIENT TEMPERATURE

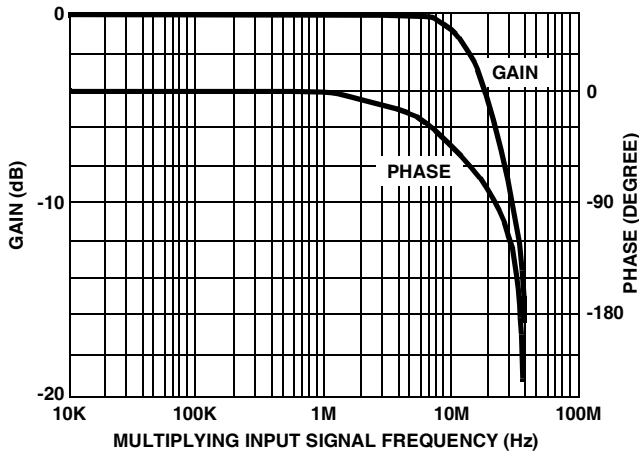

FIGURE 4. OUTPUT CHARACTERISTICS vs MULTIPLYING INPUT SIGNAL FREQUENCY

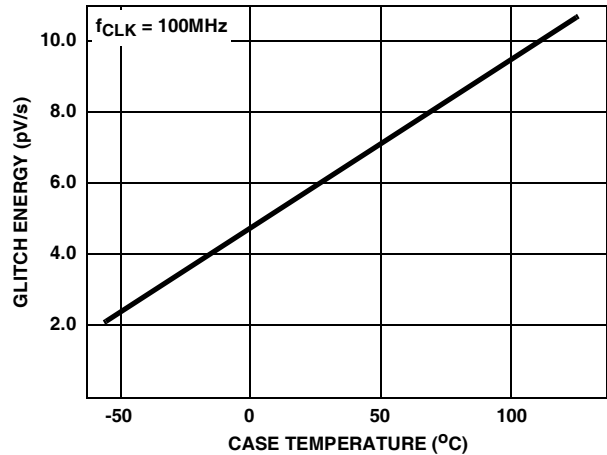

FIGURE 5. GLITCH ENERGY vs CASE TEMPERATURE (FULL SCALE - 1023mV)

Pin Descriptions

28 PIN SOIC	PIN NAME	PIN DESCRIPTION
1-8	D0 (LSB) - D7 (MSB)	Digital Data Bit 0, the Least Significant Bit thru Digital Data Bit 7, the Most Significant Bit.
11, 12, 19, 21-25	NC	No connect, not used.
13	\overline{CLK}	Negative Differential Clock Input.
14	CLK	Positive Differential Clock Input
15	DVEE	Digital (ECL) Power Supply -4.75V to -7V.
16	COMPL	Data Complement Pin. When set to a (ECL) logic High the input data is complemented in the input buffer. When cleared to a (ECL) logic Low the input data is not complemented.
17	DVSS	Digital Ground.
18	AVSS	Analog Ground.
20	IOUT	Current Output Pin.
26	AVEE	Analog Supply -4.75V to -7V.
27	VREF	Input Reference Voltage used to set the output full scale range.

HI20203

Pin Descriptions

28 PIN SOIC	PIN NAME	PIN DESCRIPTION
28	AV _{SS}	Analog Ground

Detailed Description

The HI20203 is an 8-bit, current-output D/A converter. The converter has 10 data bits but yields 8-bit performance.

Architecture

The HI20203 is a combined R2R/segmented current source design. The 6 least significant bits of the converter are derived by a traditional R2R network to binary weight the 1mA current sources. The upper 4 most significant bits are implemented as segmented or thermometer encoded current sources. The encoder converts the incoming 4 bits to 15 control lines to enable the most significant current sources. The thermometer encoder will convert binary to individual control lines. See Table 1.

TABLE 1. THERMOMETER ENCODER

MSB	BIT 6	BIT 5	BIT 4	THERMOMETER CODE 1 = ON, 0 = OFF I ₁₅ - I ₀
0	0	0	0	000 0000 0000 0000
0	0	0	1	000 0000 0000 0001
0	0	1	0	000 0000 0000 0011
0	0	1	1	000 0000 0000 0111
0	1	0	0	000 0000 0000 1111
0	1	0	1	000 0000 0001 1111
0	1	1	0	000 0000 0011 1111
0	1	1	1	000 0000 0111 1111
1	0	0	0	000 0000 1111 1111
1	0	0	1	000 0001 1111 1111
1	0	1	0	000 0011 1111 1111
1	0	1	1	000 0111 1111 1111
1	1	0	0	000 1111 1111 1111
1	1	0	1	001 1111 1111 1111
1	1	1	0	011 1111 1111 1111
1	1	1	1	111 1111 1111 1111

The architecture of the HI20203 is designed to minimize glitch while providing a manufacturable 10-bit design that does not require laser trimming to achieve good linearity.

Glitch

Glitch is caused by the time skew between bits of the incoming digital data. Typically the switching time of digital inputs are asymmetrical meaning that the turn off time is faster than the turn on time (TTL designs). In an ECL system where the logic levels switch from one non-saturated level to another, the switching times can be considered close to symmetrical. This helps to reduce glitch in the D/A. Unequal delay paths through the device can also cause one current source to change before another. To minimize this the Intersil HI20203 employs an internal register, just prior to the current sources, that is updated on the clock edge. Lastly the worst case glitch usually happens at the major transition i.e.,

01 1111 1111 to 10 0000 0000. But in the HI20203 the glitch is moved to the 00 0001 1111 to 11 1110 0000 transition. This is achieved by the split R2R/segmented current source architecture. This decreases the amount of current switching at any one time and makes the glitch practically constant over the entire output range. By making the glitch a constant size over the entire output range this effectively integrates this error out of the end application.

In measuring the output glitch of the HI20203 the output is terminated into a 75Ω load. The glitch is measured at the major carry's throughout the DACs output range.

The glitch energy is calculated by measuring the area under the voltage-time curve. Figure 7 shows the area considered as glitch when changing the DAC output. Units are typically specified in picoVolt/seconds (pV/s).

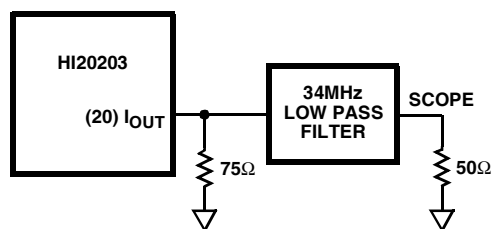

FIGURE 6. HI20203 GLITCH TEST CIRCUIT

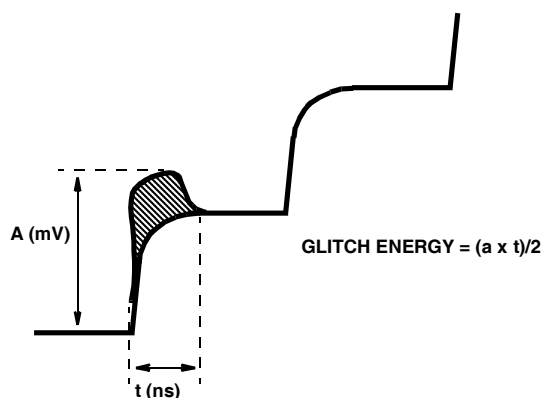

FIGURE 7. GLITCH ENERGY

Setting Full Scale

The Full Scale output voltage is set by the Voltage Reference pin (27). The output voltage performance will vary as shown in Figure 2.

The output structure of the HI20203 can handle down to a 75Ω load effectively. To drive a 50Ω load Figure 8 is

HI20203

suggested. Note the equivalent output load is $\sim 75\Omega$.

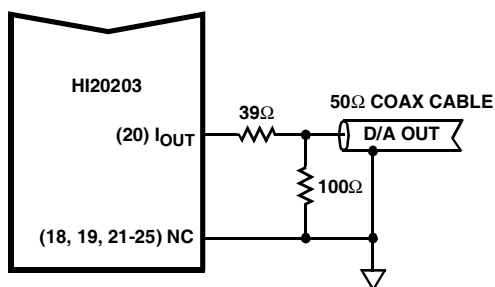

FIGURE 8. HI20203 DRIVING A 50Ω LOAD

Variable Attenuator Capability

The HI20203 can be used in a multiplying mode with a variable frequency input on the V_{REF} pin. In order for the part to operate correctly a DC bias must be applied and the incoming AC signal should be coupled to the V_{REF} pin. See Figure 13 for the application circuit. The user must first adjust the DC reference voltage. The incoming signal must be attenuated so as not to exceed the maximum (+1.4V) and minimum (+0.5V) reference input. The typical output Small Signal Bandwidth is 14MHz.

Integral Linearity

The Integral Linearity is measured using the End Point method. In the End Point method the gain is adjusted. A line is then established from the zero point to the end point or Full Scale of the converter. All codes along the transfer curve must fall within an error band of 1 LSB of the line. Figure 10 shows the linearity test circuit.

Differential Linearity

The Differential Linearity is the difference from the ideal step. To guarantee monotonicity a maximum of 1 LSB differential error is allowed. When more than 1 LSB is specified the converter is considered to be missing codes. Figure 10 shows the linearity test circuit.

Clock Phase Relationship

The HI20203 is designed to be operated at very high speed (i.e., 160MHz). The clock lines should be driven with ECL100K logic for full performance. Any external data drivers and clock drivers should be terminated with 50Ω to minimize reflections and ringing.

Internal Data Register

The HI20203 incorporates a data register as shown in the Functional Block Diagram. This register is updated on the rising edge of the CLK line. The state of the Complement bit (COMPL) will determine the data coding. See Table 2.

TABLE 2. INPUT CODING TABLE

INPUT CODE	OUTPUT CODE	
	COMPL = 1	COMPL = 0
00 0000 0000	0	-1
10 0000 0000	-0.5	-0.5
11 1111 1111	-1	0

Thermal Considerations

The temperature coefficient of the full scale output voltage and zero offset voltage depend on the load resistance connected to I_{OUT} . The larger the load resistor the better (i.e., smaller) the temperature coefficient of the D/A. See Figure 3 in the performance curves section.

Noise Reduction

Digital switching noise must be minimized to guarantee system specifications. Since 1 LSB corresponds to 1mV for 10-bit resolution, care must be taken in the layout of a circuit board.

Separate ground planes should be used for DV_{SS} and AV_{SS} . They should be connected back at the power supply.

Separate power planes should be used for DV_{EE} and AV_{EE} . They should be decoupled with a 1μF tantalum capacitor and a ceramic 0.047μF capacitor positioned as close to the body of the IC as possible.

Test Circuits and Waveforms

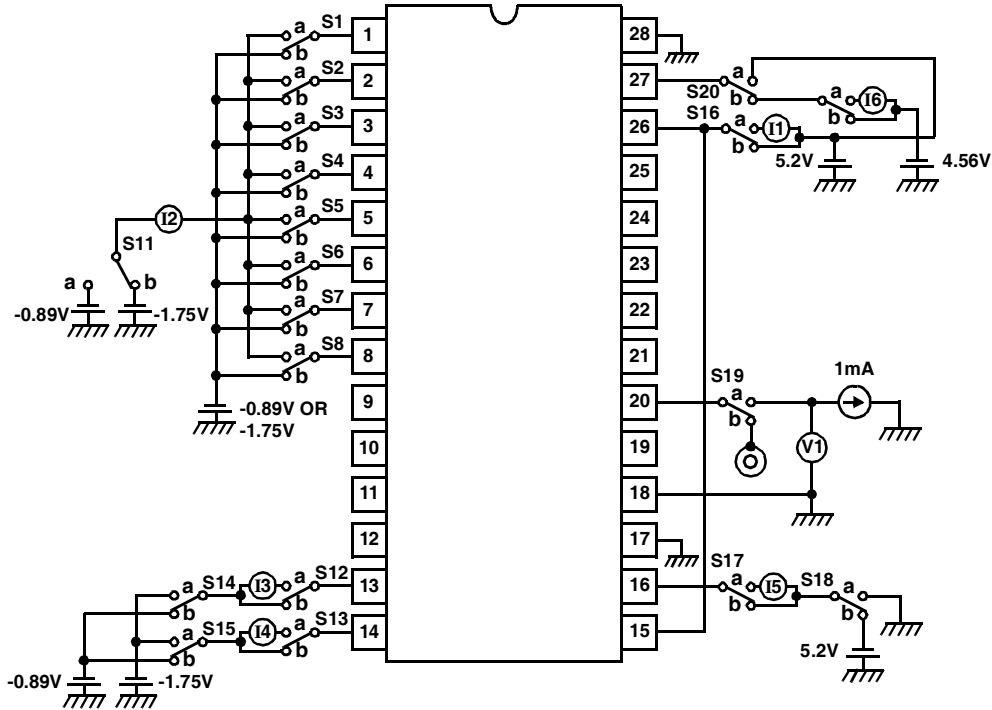
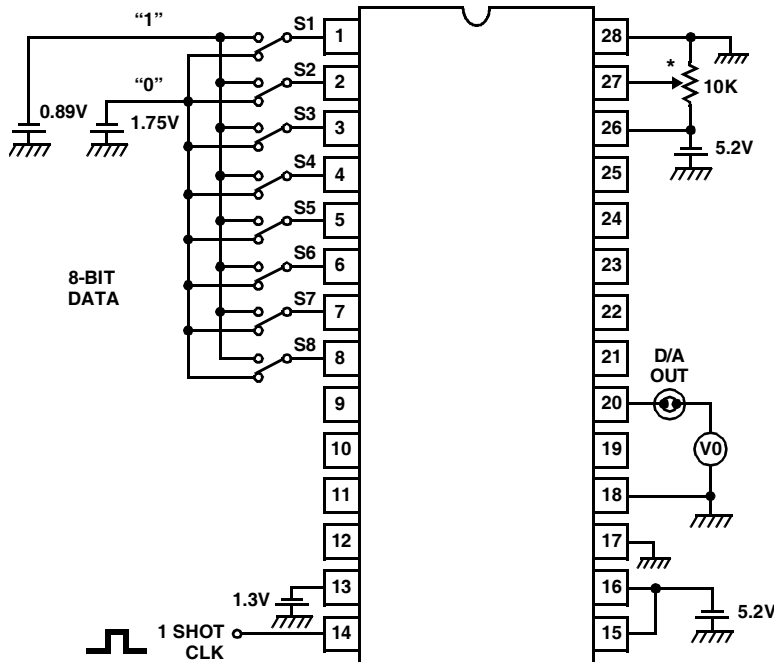

FIGURE 9. CURRENT CONSUMPTION, INPUT CURRENT AND OUTPUT RESISTANCE



LINEARITY ERRORS ARE MEASURED AS FOLLOWS

S1	S2	S3	...	S7	S8	D/A OUT
0	0	0	...	0	0	V ₀
0	0	0	...	0	1	V ₁
0	0	0	...	1	0	V ₂
			...			⋮
1	1	1	...	1	1	V ₂₅₅

INTEGRAL LINEARITY ERROR	DIFFERENTIAL LINEARITY ERROR
V ₀	V ₁ - V ₀
V ₁	V ₂ - V ₁
V ₂	V ₄ - V ₃
V ₄	V ₈ - V ₇
V ₈	V ₁₆ - V ₁₅
V ₁₆	V ₃₂ - V ₃₁
V ₃₂	V ₆₄ - V ₆₃
V ₆₄	V ₁₂₈ - V ₁₂₇
V ₁₂₈	⋮
⋮	⋮
V ₂₅₅	⋮

Error at individual measurement points are calculated according to the following definition.
 $(V_{255} - V_0)/1023 = V_0(FS)/255 \approx 1 \text{ LSB}$.

FIGURE 10. DIFFERENTIAL LINEARITY ERROR AND LINEARITY ERROR

Test Circuits and Waveforms (Continued)

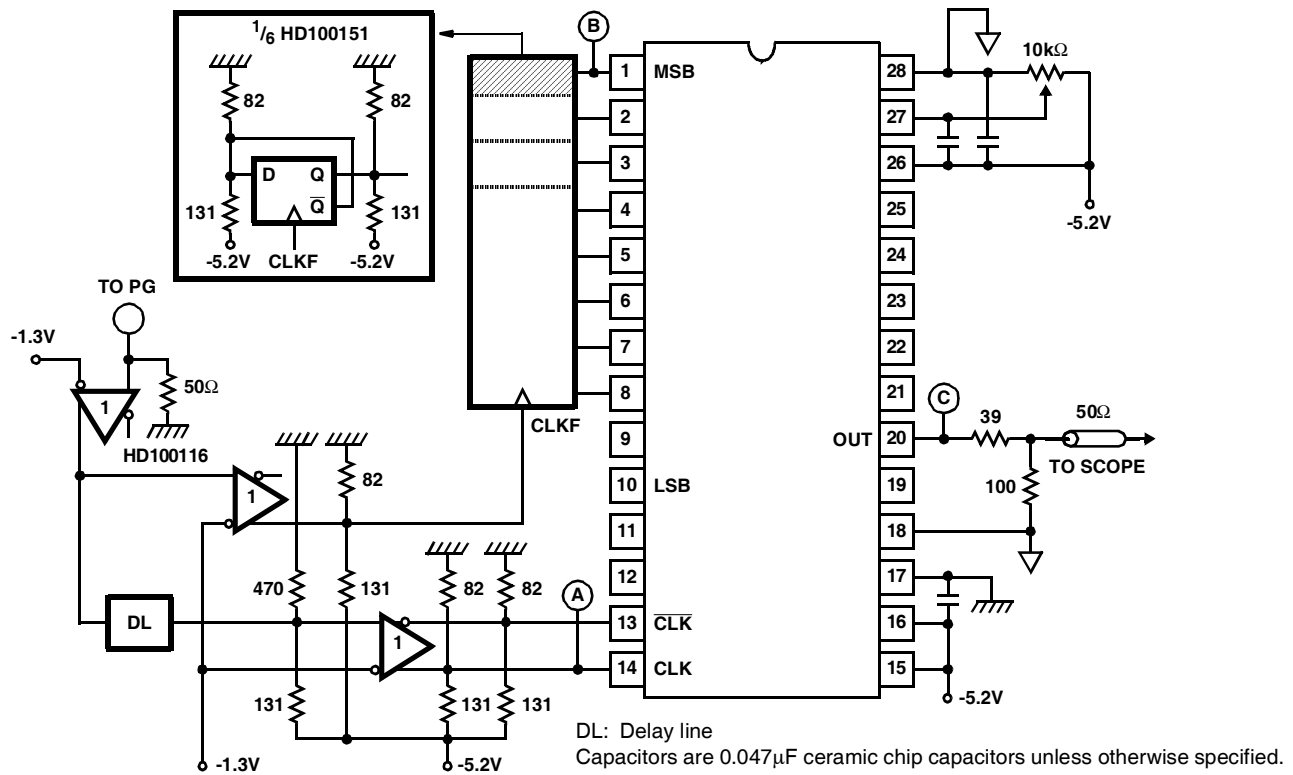

FIGURE 11. MAXIMUM CONVERSION RATE, RISE TIME, FALL TIME, PROPAGATION DELAY, SETUP TIME, HOLD TIME AND SETTLING TIME

Measuring Settling Time

Settling time is measured as follows. The relationship between V and $V_{0(FS)}$ as shown in the D/A output waveform in Figure 12 is expressed as

$$V = V_{0(FS)} (1 - e^{-t/\tau})$$

The settling time for respective accuracy of 10, 9 and 8-bit is specified as

$$V = 0.9995 V_{0(FS)}$$

$$V = 0.999 V_{0(FS)}$$

$$V = 0.999 V_{0(FS)}$$

which results in the following:

$$t_S = 7.60\tau \text{ for 10-bit,}$$

$$t_S = 6.93\tau \text{ for 9-bit, and}$$

$$t_S = 6.24\tau \text{ for 8-bit,}$$

Rise time (t_r) and fall time (t_f) are defined as the time interval to slew from 10% to 90% of full scale voltage ($V_{0(FS)}$):

$$V = 0.1 V_{0(FS)}$$

$$V = 0.9 V_{0(FS)}$$

and calculated as $t_r = t_f = 2.20\tau$.

The settling time is obtained by combining these expressions:

$$t_S = 3.45t_r \text{ for 10-bit,}$$

$$t_S = 3.15t_r \text{ for 9-bit, and}$$

$$t_S = 6.24t_r \text{ for 8-bit}$$

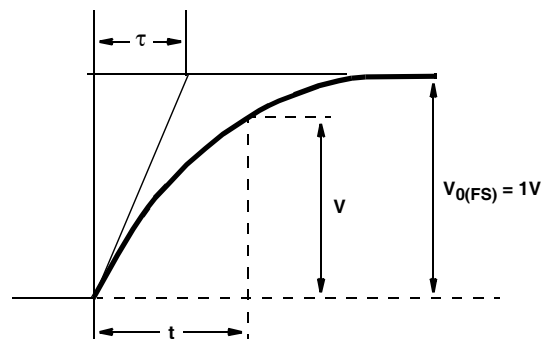

FIGURE 12. D/A OUTPUT WAVEFORM

Test Circuits and Waveforms (Continued)

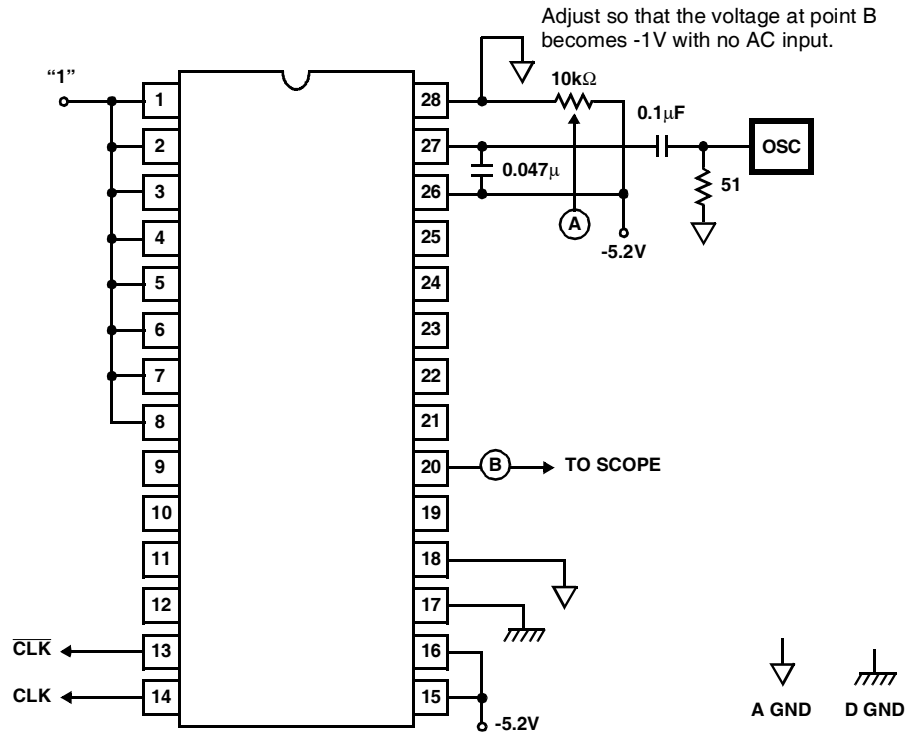

FIGURE 13A.

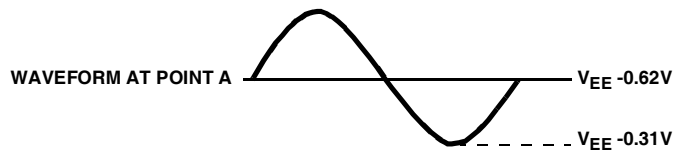

FIGURE 13B.

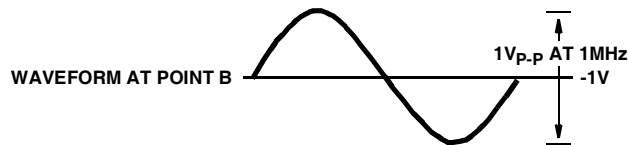

FIGURE 13C.

FIGURE 13. MULTIPLYING BANDWIDTH