

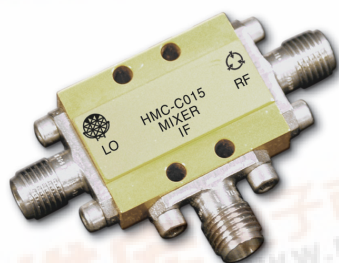

HMC-C015

GaAs MMIC DOUBLE BALANCED MIXER MODULE, 24 - 38 GHz



Typical Applications

The HMC-C015 is ideal for:

- Telecom Infrastructure
- Military Radio, Radar & ECM
- Space Systems
- Test Instrumentation

Functional Diagram

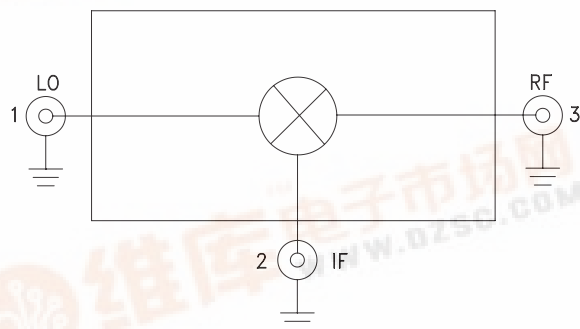

Features

- Passive: No DC Bias Required
- Input IP3: +20 dBm
- LO/RF Isolation: 35 dB
- Wide IF Bandwidth: DC - 8 GHz
- Hermetically Sealed Module
- Field Replaceable Coaxial Connectors
- 55 to +85 °C Operating Temperature

General Description

The HMC-C015 is a general purpose double-balanced mixer housed in a miniature hermetic module which can be used as an upconverter or downconverter between 24 and 38 GHz. This mixer requires no external components or matching circuitry. The HMC-C015 provides excellent, LO to RF, and LO to IF suppression due to optimized balun structures. The mixer operates with LO drive levels from +11 to +15 dBm and requires no DC bias. The HMC-C015 may also be used as a Bi-Phase Modulator/Demodulator or phase comparator. The module features removable coaxial connectors which can be detached to allow direct connection of the I/O pins to a microstrip or coplanar circuit.

Electrical Specifications, $T_A = +25^\circ C$, $IF = 1 GHz$, $LO = +13 dBm^*$

Parameter	Min.	Typ.	Max.	Units
Frequency Range, RF & LO	24 - 38			GHz
Frequency Range, IF	DC - 8			GHz
Conversion Loss		9	12	dB
Noise Figure (SSB)		9	12	dB
LO to RF Isolation	27	35		dB
LO to IF Isolation	30	40		dB
RF to IF Isolation	20	30		dB
IP3 (Input)		20		dBm
IP2 (Input)		55		dBm
1 dB Gain Compression (Input)		11		dBm

*Unless otherwise noted, all measurements performed as downconverter, IF= 1 GHz.

GaAs MMIC DOUBLE BALANCED MIXER MODULE, 24 - 38 GHz

Conversion Gain vs. Temperature

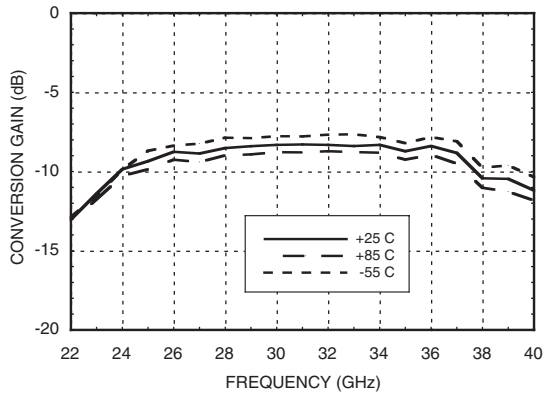

Isolation

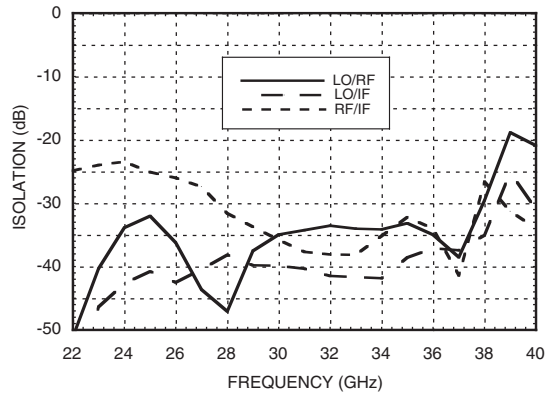

Conversion Gain vs. LO Drive

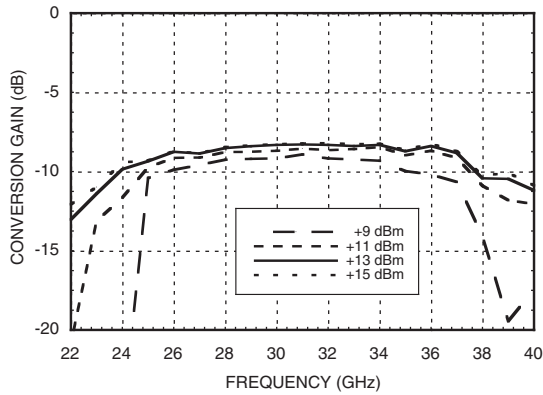

Return Loss

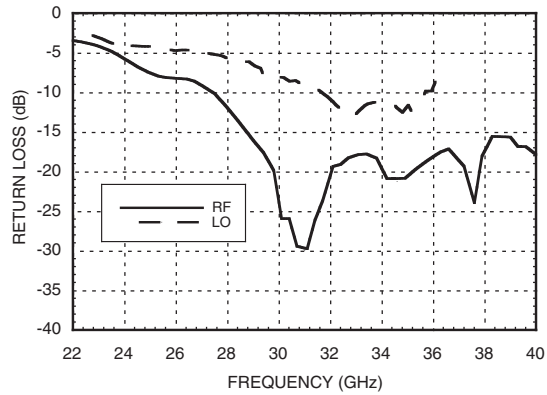

IF Bandwidth

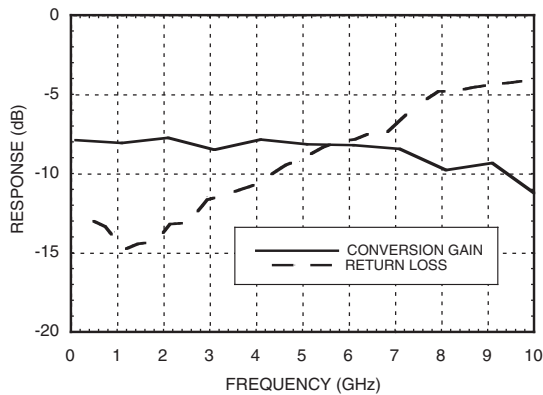

**Upconverter Performance
Conversion Gain vs. LO Drive**

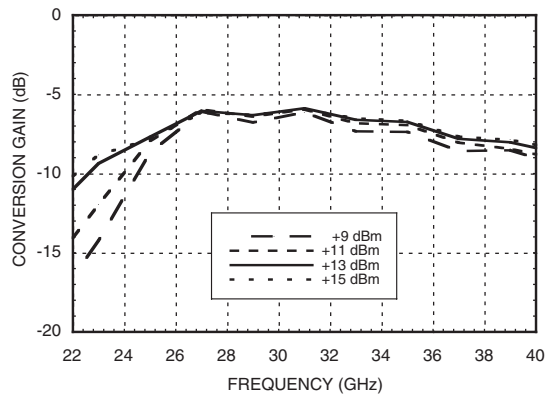

GaAs MMIC DOUBLE BALANCED MIXER MODULE, 24 - 38 GHz

Input IP3 vs. LO Drive *

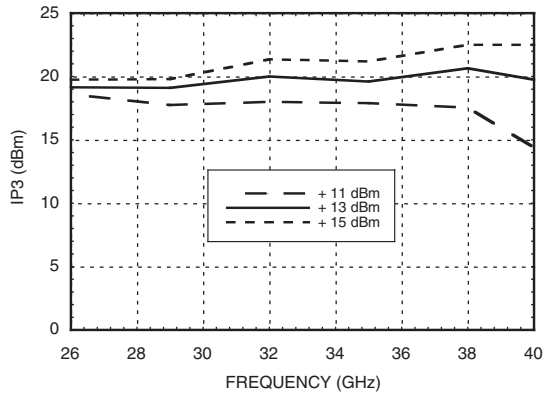

Input IP3 vs. Temperature*

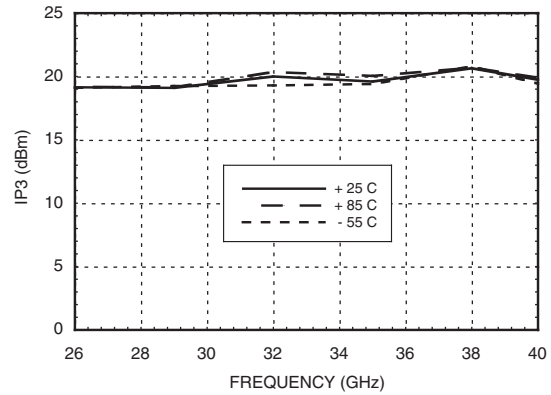

Input IP2 vs. LO Drive *

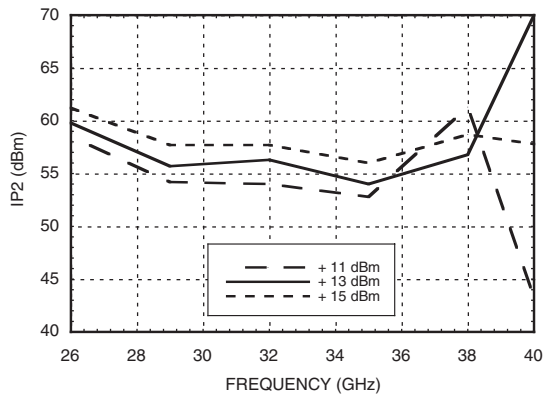

Input IP2 vs. Temperature*

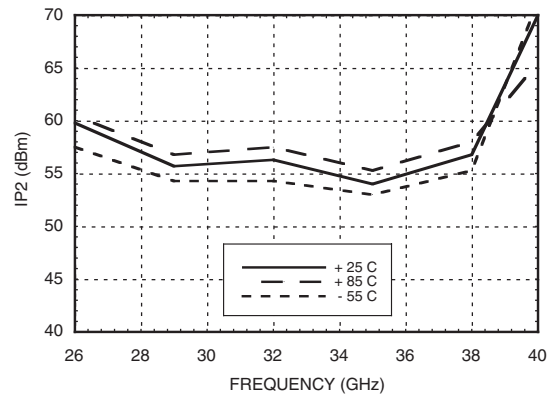

Input P1dB vs. Temperature

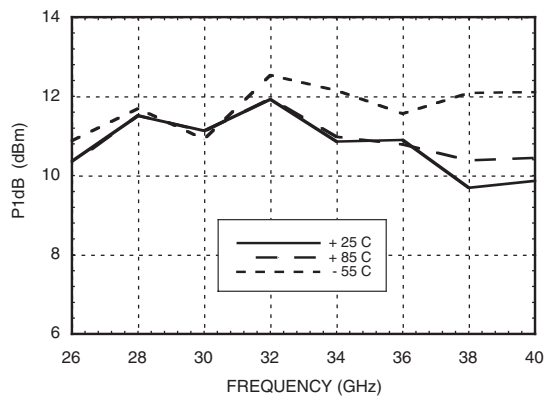

* Two-tone input power = -10 dBm each tone, 1 MHz spacing.

GaAs MMIC DOUBLE BALANCED MIXER MODULE, 24 - 38 GHz

MxN Spurious Outputs

mRF	nLO				
	0	1	2	3	4
0	xx	10	xx	xx	xx
1	23	0	45	xx	xx
2	xx	72	58	72	xx
3	xx	xx	103	68	90
4	xx	xx	xx	103	104

RF = 28 GHz @ -10 dBm
LO = 27 GHz @ +13 dBm
All values in dBc below the IF output power level.

Absolute Maximum Ratings

RF / IF Input	+13 dBm
LO Drive	+27 dBm
Storage Temperature	-65 to +150 °C
Operating Temperature	-55 to +85 °C



**ELECTROSTATIC SENSITIVE DEVICE
OBSERVE HANDLING PRECAUTIONS**

**GaAs MMIC DOUBLE BALANCED
MIXER MODULE, 24 - 38 GHz**

Outline Drawing

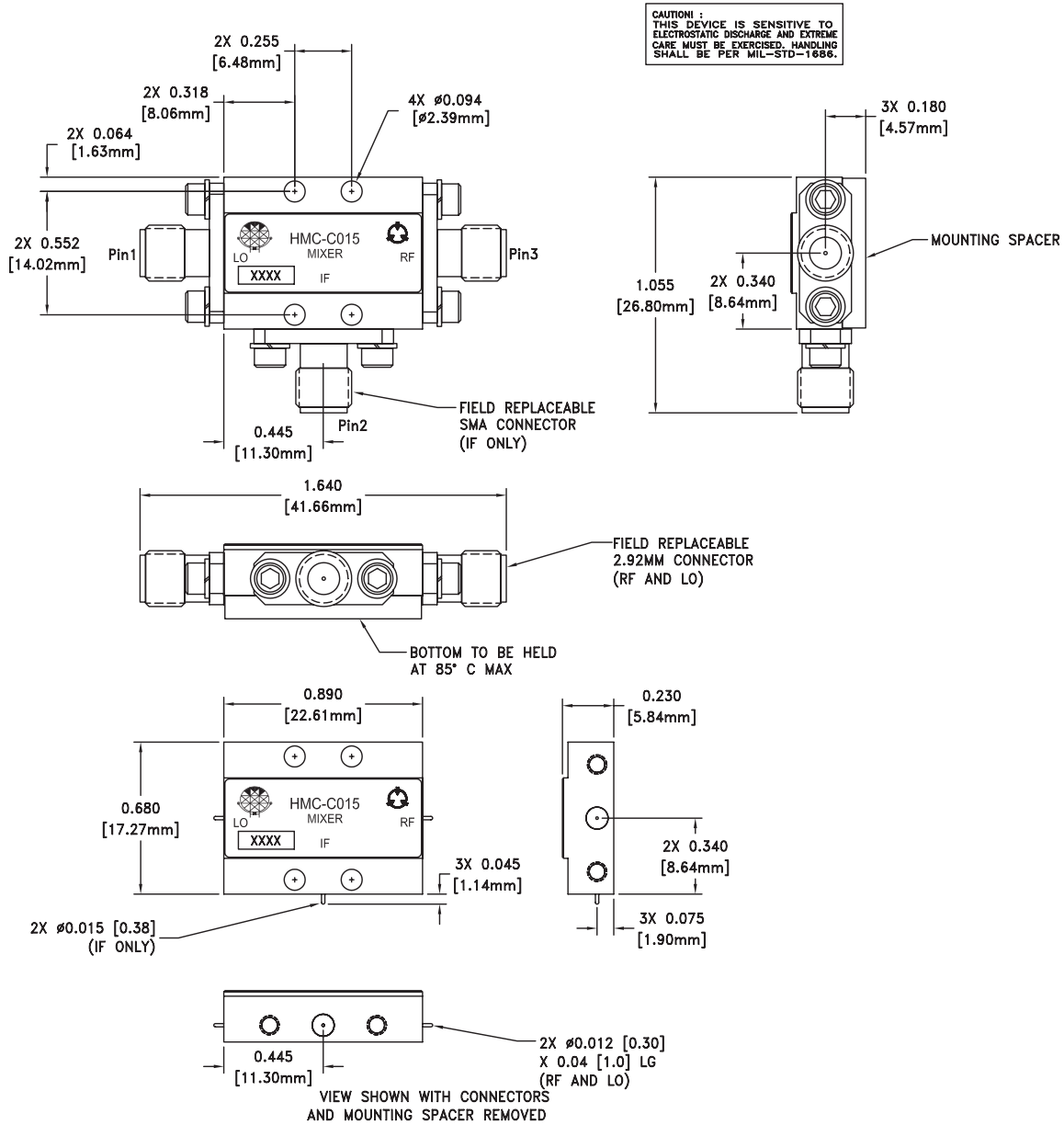

NOTES:

1. PACKAGE, LEADS, COVER MATERIAL: KOVAR™
2. SPACER MATERIAL: ALUMINUM
3. PLATING: ELECTROLYTIC GOLD 50 MICROINCHES MIN., OVER ELECTROLYTIC NICKEL 75 MICROINCHES MIN.
4. ALL DIMENSIONS ARE IN INCHES [MILLIMETERS].
5. TOLERANCES \pm .005 [0.13] UNLESS OTHERWISE SPECIFIED.
6. FIELD REPLACEABLE SMA CONNECTORS. TENSOLITE 5602-5CCSF OR EQUIVALENT.
7. FIELD REPLACEABLE 2.92mm CONNECTOR: TENSOLITE 231CCSF

**GaAs MMIC DOUBLE BALANCED
MIXER MODULE, 24 - 38 GHz**

Pin Descriptions

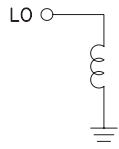
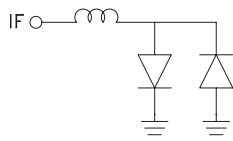
Pin Number	Function	Description	Interface Schematic
1	LO	This pin is DC coupled and matched to 50 Ohm from 24 to 38 GHz.	
2	IF	This pin is DC coupled. For applications not requiring operation to DC, this port should be DC blocked externally using a series capacitor whose value has been chosen to pass the necessary IF frequency range. For operation to DC, this pin must not source or sink more than 2 mA of current or part non-function and possible part failure will result.	
3	RF	This pin is DC coupled and matched to 50 Ohm from 24 to 38 GHz.	