



HMC121

GaAs MMIC VOLTAGE-VARIABLE ATTENUATOR DC - 15 GHz

SEPTEMBER 1999

Features

- WIDE BANDWIDTH: DC - 15 GHz
- LOW PHASE SHIFT VS. ATTENUATION
- 30 dB ATTENUATION RANGE
- SIMPLIFIED VOLTAGE CONTROL

General Description

The HMC121 chip is an absorptive voltage variable attenuator. It features an on-chip reference attenuator for use with an external op-amp to provide simple single voltage attenuation control. The device is ideal in designs where analog control signal must control RF signal levels over a 30 dB range, such as AGC circuits and in temperature compensation of multiple gain stages. Applications include military ECM and communications as well as commercial microwave radios and VSAT. See SMT packaged version HMC121G8 (hermetic).

2

Attenuators

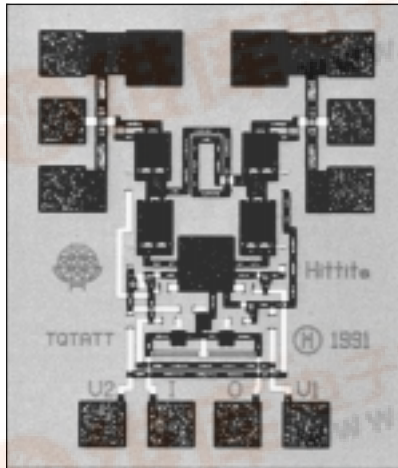

Guaranteed Performance, 50 ohm system, -55 to +85 deg C

Parameter	Min.	Typ.	Max.	Units
Insertion Loss	DC - 8 GHz:	1.8	2.8	dB
	DC - 15 GHz:	2	3.5	dB
Attenuation Range	25	30		dB
Return Loss	DC - 8 GHz:	13	18	dB
	DC - 15 GHz:	10	15	dB
Switching Characteristics	tRISE, tFALL (10/90% RF):	3		ns
	tON, tOFF (50% CTL to 10/90% RF):	6		ns
Input Power for 0.25dB Comp. (0.5 - 15 GHz)	Min. Atten:	+10		dBm
	Atten. > 2dB:	-2		dBm
Input Third Order Intercept (typ - 8 dBm signals 0.5 - 15 GHz)	Min. Atten:	+25		dBm
	Atten. > 2dB:	+10		dBm

HMC121 VOLTAGE-VARIABLE ATTENUATOR DC - 15 GHz

SEPTEMBER 1999

Insertion Loss

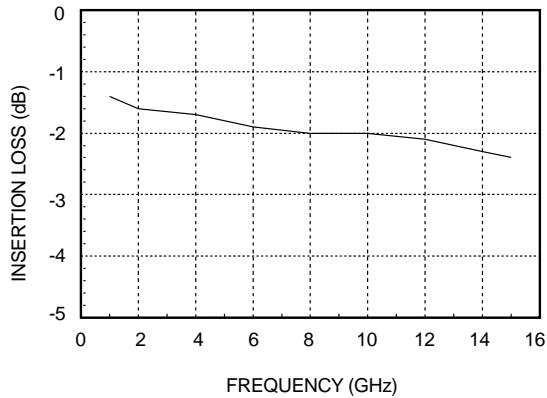

Relative Attenuation

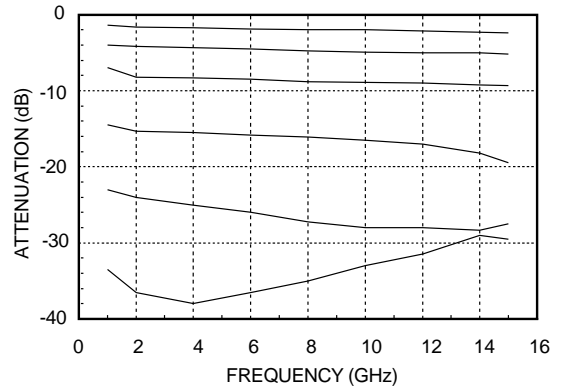

Return Loss

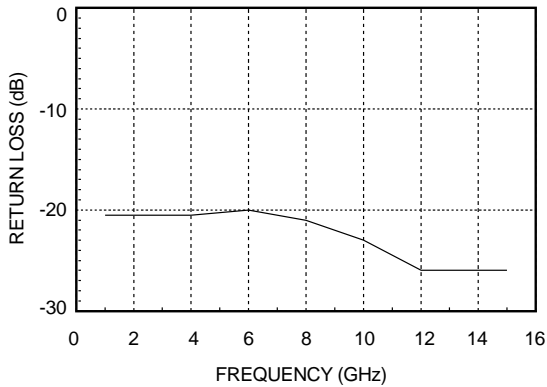

Relative Attenuation vs. Control Voltage

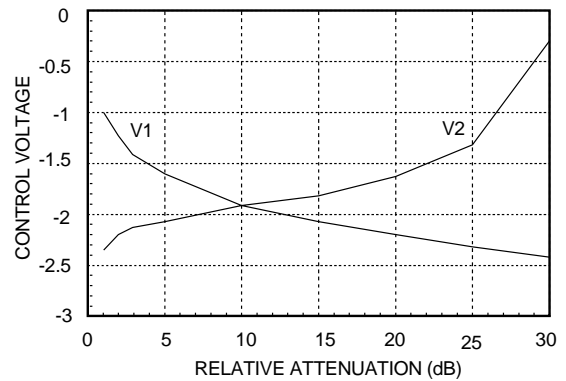

Relative Phase

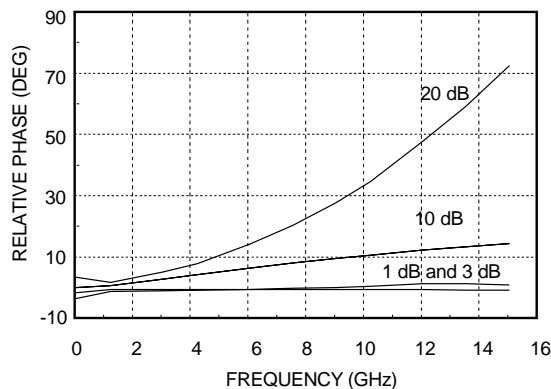

HMC121 VOLTAGE-VARIABLE ATTENUATOR DC - 15 GHz

SEPTEMBER 1999

Schematic

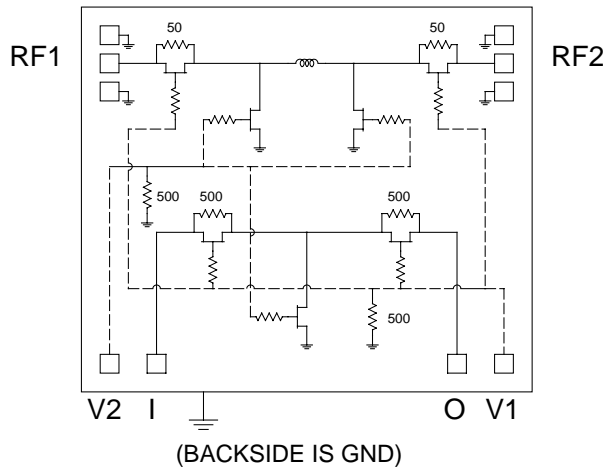

Single-Line Control Driver

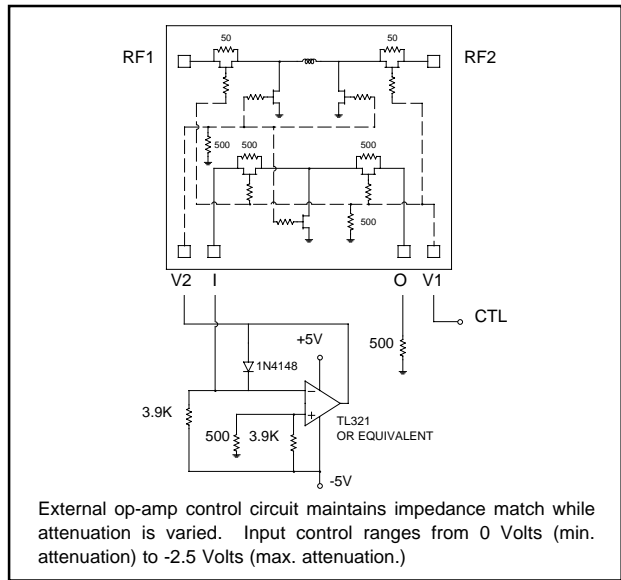

Outline Drawing

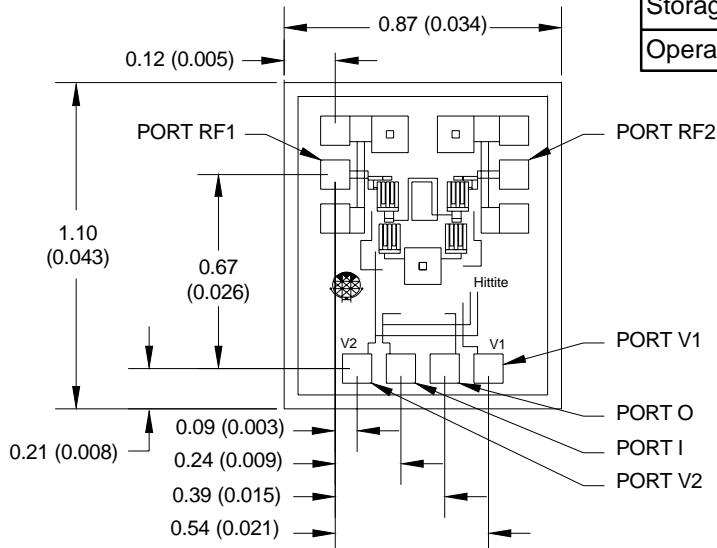

Absolute Maximum Ratings

RF Input	+16dBm
Control Voltage Range	+1.0 to -6.0 Vdc
Storage Temperature	-65 to +150 deg C
Operating Temperature	-55 to +125 deg C

ALL TOLERANCES ARE: ± 0.025 (0.001)
 DIE THICKNESS IS 0.10 (0.004), BACKSIDE IS GROUND
 BOND PADS ARE 0.10 (0.004) SQUARE
 ALL DIMENSIONS IN MILLIMETERS (INCHES)
 BACKSIDE METALLIZATION: GOLD
 BOND PAD METALLIZATION: GOLD

Handling Precautions

Follow these precautions to avoid permanent damage.

Cleanliness: Handle the chips in a clean environment. DO NOT attempt to clean the chip using liquid cleaning systems.

Static Sensitivity: Follow ESD precautions to protect against $\geq \pm 250\text{V}$ ESD strikes. (*see page 8 - 2*)

Transients: Suppress instrument and bias supply transients while bias is applied. Use shielded signal and bias cables to minimize inductive pick-up.

General Handling: Handle the chip along the edges with a vacuum collet or with a sharp pair of bent tweezers. The surface of the chip has fragile air bridges and should not be touched with vacuum collet, tweezers, or fingers.

Mounting

The chip is back-metallized and can be die mounted with AuSn eutectic preforms or with electrically conductive epoxy. The mounting surface should be clean and flat.

Eutectic Die Attach:

A 80/20 gold tin preform is recommended with a work surface temperature of 255 deg. C and a tool temperature of 265 deg. C. When hot 90/10 nitrogen/hydrogen gas is applied, tool tip temperature should be 290 deg. C.

DO NOT expose the chip to a temperature greater than 320 deg. C for more than 20 seconds. No more than 3 seconds of scrubbing should be required for attachment.

Epoxy Die Attach:

Apply a minimum amount of epoxy to the mounting surface so that a thin epoxy fillet is observed around the perimeter of the chip once it is placed into position.

Cure epoxy per the manufacturer's schedule.

Wire Bonding

Ball or wedge bond with 1.0 diameter pure gold wire. Thermosonic wirebonding with a nominal stage temperature of 150 deg. C and a ball bonding force of 40 to 50 grams or wedge bonding force of 18 to 22 grams is recommended. Use the minimum level of ultrasonic energy to achieve reliable wirebonds.

Wirebonds should be started on the chip and terminated on the package. RF bonds should be as short as possible.