



HMC344LH5

GaAs MMIC SP4T NON-REFLECTIVE SWITCH, DC - 12 GHz

Typical Applications

This switch is suitable for DC - 12.0 GHz 50-Ohm Systems

- Telecom Infrastructure
- Military Radio, Radar & ECM
- Space Systems
- Test Instrumentation

Features

- Broadband Performance: DC - 12 GHz
- High Isolation: 42 dB@ 6 GHz
- Low Insertion Loss: 1.8 dB@ 6 GHz
- Integrated 2:4 TTL Decoder
- Hermetic SMT Package, 25 mm²
- Screening to MIL-PRF-38535 (Class B or S) Available

Functional Diagram

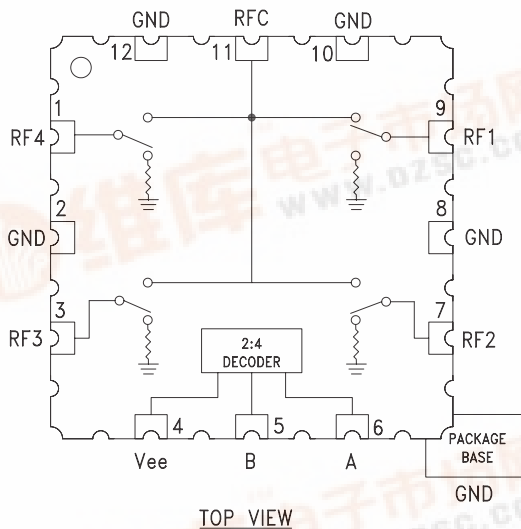

General Description

The HMC344LH5 is a broadband non-reflective GaAs MESFET SP4T switch in a hermetic SMT leadless package. Covering DC to 12 GHz, this switch offers high isolation and low insertion loss. This switch also includes an on board binary decoder circuit which reduces the required logic control lines to two. The switch operates using a negative control voltage of 0/-5V, and requires a fixed bias of -5V. Simple external level shifting circuitry allows this switch to be controlled with most TTL/CMOS positive logic families. The HMC344LH5 allows the use of surface mount manufacturing techniques and is suitable for high reliability military, industrial and space applications.

Electrical Specifications, $T_A = +25^\circ C$, With Vee = -5V & 0/-5V Control, 50 Ohm System

Parameter	Frequency	Min.	Typ.	Max.	Units
Insertion Loss	DC - 2.0 GHz		1.5	1.9	dB
	DC - 6.0 GHz		1.8	2.2	dB
	DC - 8.0 GHz		2.1	2.5	dB
	DC - 12.0 GHz		3.0	3.4	dB
Isolation	DC - 2.0 GHz	48	53		dB
	DC - 4.0 GHz	43	48		dB
	DC - 6.0 GHz	37	42		dB
	DC - 8.0 GHz	35	40		dB
	DC - 12.0 GHz	30	35		dB
Return Loss	"On State"	DC - 10.0 GHz		17	dB
		DC - 12.0 GHz		12	dB
Return Loss	"Off State"	DC - 8.0 GHz		16	dB
		DC - 12.0 GHz		10	dB
Input Power for 1 dB Compression	0.5 - 12.0 GHz	24	27		dBm
Input Third Order Intercept (Two-Tone Input Power = +7 dBm Each Tone)	0.5 - 4.0 GHz		50		dBm
	4.0 - 8.0 GHz		47		dBm
	8.0 - 12.0 GHz		44		dBm
Switching Characteristics tRISE, tFALL (10/90% RF)	DC - 12.0 GHz		35		ns
		tON, tOFF (50% CTL to 10/90% RF)		75	



Insertion Loss vs. Temperature

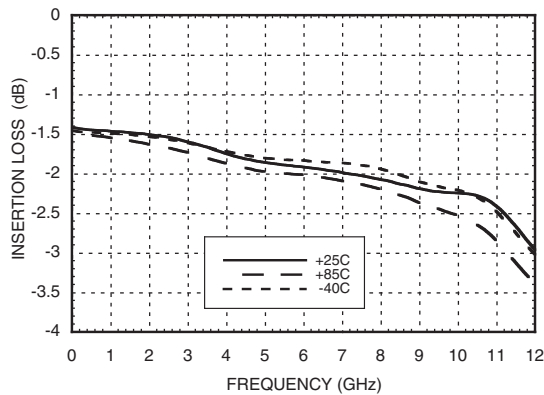

Isolation

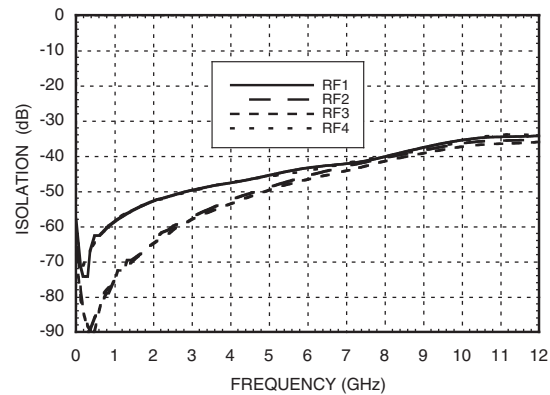

Return Loss

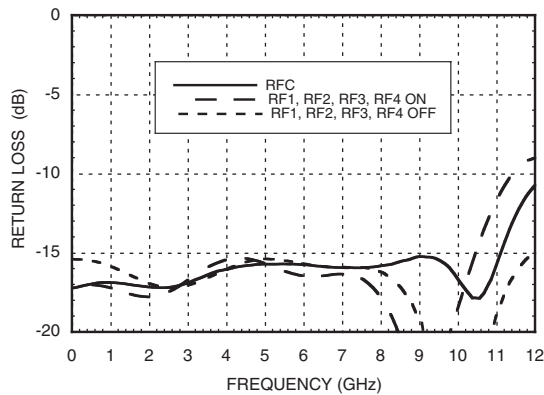

0.1 and 1 dB Input Compression Point

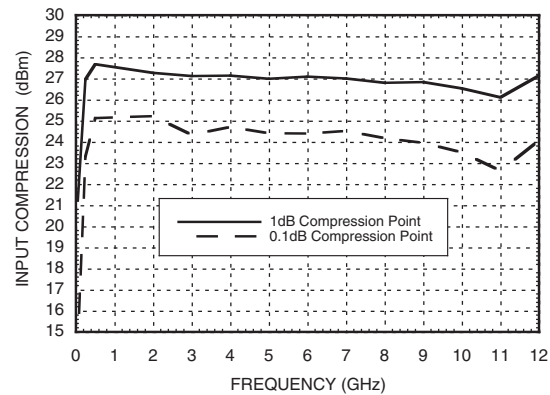

Input Third Order Intercept Point

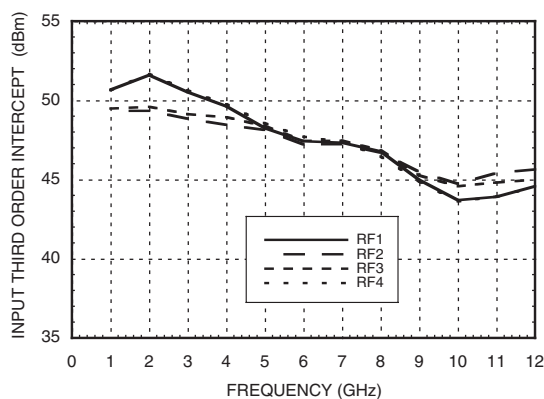

Bias Voltage & Current

Vee Range = -5.0 Vdc ± 10%		
Vee (Vdc)	Iee (Typ.) (mA)	Iee (Max.) (mA)
-5.0	3.0	6.0

Control Voltages

State	Bias Condition
Low	-3V to 0 Vdc @ 40 uA Typical
High	-5 to -4.2 Vdc @ 5 uA Typical

* Isolation is recorded above insertion loss & measured at output of switch.



GaAs MMIC SP4T NON-REFLECTIVE SWITCH, DC - 12 GHz

Absolute Maximum Ratings

Bias Voltage Range (V _{ee})	-7.0 Vdc
Control Voltage Range (A & B)	V _{ee} -0.5V to +1.0 Vdc
Channel Temperature	150 °C
Thermal Resistance (Insertion Loss Path)	157 °C/W
Continuous Pdiss (T= 85 °C) (derate 6.4 mW/°C above 85 °C)	0.42 W
Thermal Resistance (Terminated Path)	264 °C/W
Continuous Pdiss (T= 85 °C) (derate 3.8 mW/°C above 85 °C)	0.25 W
Storage Temperature	-65 to +150 °C
Operating Temperature	-40 to +85 °C
Maximum Input Power	+28 dBm (0.5 - 12.0 GHz)
ESD Sensitivity (HBM)	Class 1A

Truth Table

Control Input		Signal Path State
A	B	RFC to:
High	High	RF1
Low	High	RF2
High	Low	RF3
Low	Low	RF4



**ELECTROSTATIC SENSITIVE DEVICE
OBSERVE HANDLING PRECAUTIONS**

Outline Drawing

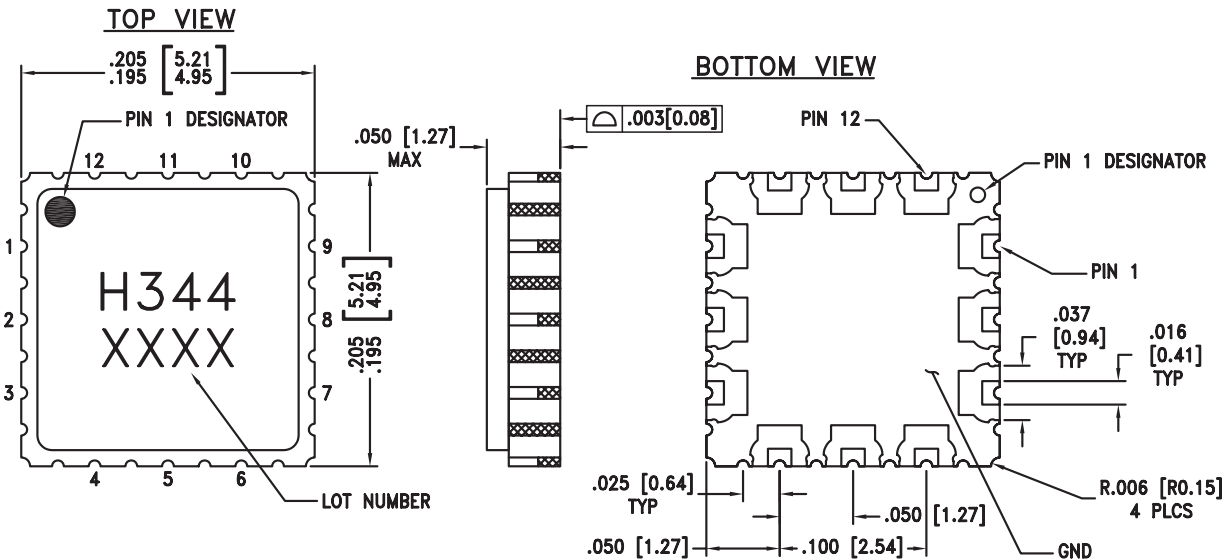

NOTES:

1. PACKAGE BODY MATERIAL: CERAMIC & KOVAR
2. LEAD AND GROUND PADDLE PLATING: GOLD 40 - 80 MICROINCHES.
3. DIMENSIONS ARE IN INCHES [MILLIMETERS].
4. LEAD SPACING TOLERANCE IS NON-CUMULATIVE
5. PAD BURR LENGTH 0.15mm MAX.
PAD BURR HEIGHT 0.25mm MAX.
6. ALL GROUND LEADS AND GROUND PADDLE MUST BE SOLDERED TO PCB RF GROUND.

Pin Descriptions

Pin Number	Function	Description	Interface Schematic
1, 3, 7, 9, 11	RF4, RF3, RF2, RF1, RFC	This pin is DC coupled and matched to 50 Ohm. Blocking capacitors are required if RF line potential is not equal to 0V.	
2, 8, 10, 12	GND	Package base must also be connected to PCB RF ground.	
4	Vee	Supply Voltage -5V ± 10%	
5	B	See truth table and control voltage table.	
6	A	See truth table and control voltage table.	

TTL Interface Circuit

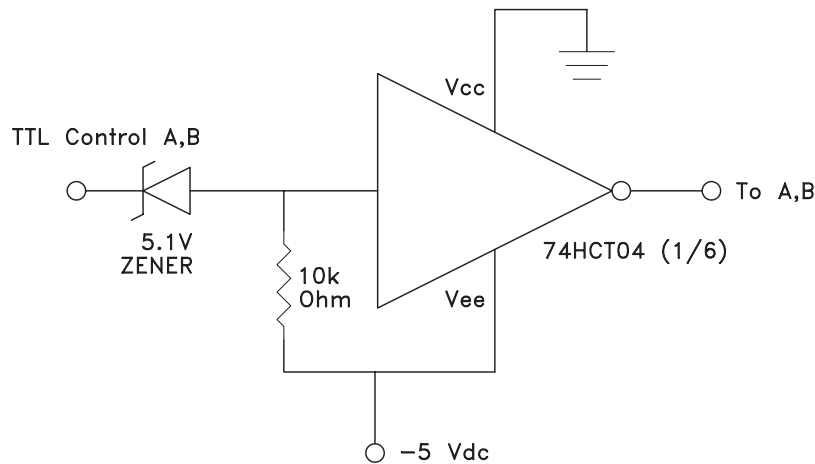

Evaluation PCB

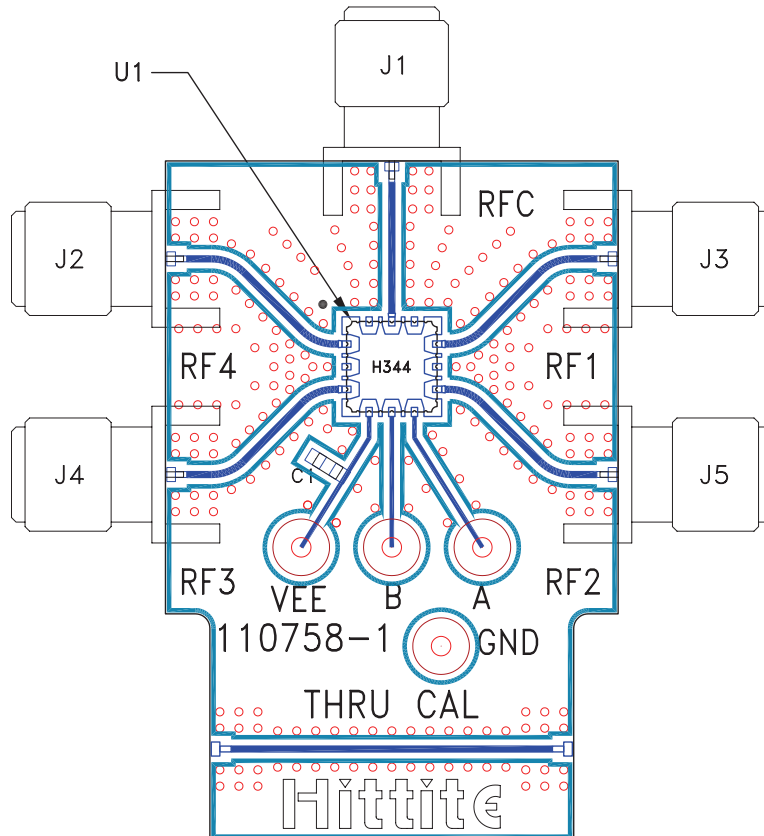

List of Materials for Evaluation PCB 110760 [1]

Item	Description
J1 - J5	PCB Mount SMA RF Connector
J6 - J9	DC Pin
C1	10k pF Capacitor, 0603 Pkg.
U1	HMC344LH5 SP4T Switch
PCB [2]	110758 Evaluation PCB

[1] Reference this number when ordering complete evaluation PCB

[2] Circuit Board Material: Rogers 4350

The circuit board used in the final application should be generated with proper RF circuit design techniques. Signal lines at the RF port should have 50 ohm impedance and the package ground leads and package base should be connected directly to the ground plane similar to that shown above. The evaluation circuit board shown above is available from Hittite Microwave Corporation upon request.



v05.0505



HMC344LH5

**GaAs MMIC SP4T NON-REFLECTIVE
SWITCH, DC - 12 GHz**

Notes: