

查询HMC575LP4供应商

捷多邦, 专业PCB打样工厂, 24小时加急出货



HMC575LP4 / 575LP4E

SMT GaAs MMIC x2 ACTIVE FREQUENCY MULTIPLIER, 6 - 9 GHz OUTPUT

Typical Applications

The HMC575LP4 / HMC575LP4E is suitable for:

- Wireless Local Loop
- Point-to-Point & VSAT Radios
- Test Instrumentation
- Military & Space

Features

- High Output Power: +17 dBm
- Low Input Power Drive: -2 to +6 dBm
- Fo, 3Fo Isolation: 15 dBc
- 100 KHz SSB Phase Noise: -140 dBc/Hz
- Single Supply: +5V@ 90 mA
- RoHS Compliant 4x4 mm SMT Package

Functional Diagram

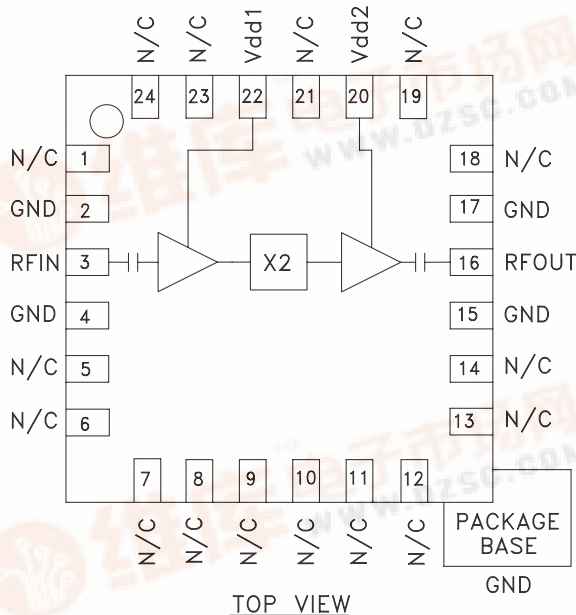

General Description

The HMC575LP4 & HMC575LP4E are x2 active broadband frequency multipliers utilizing GaAs PHEMT technology in a leadless RoHS compliant SMT package. When driven by a 3 dBm signal, the multiplier provides +17 dBm typical output power from 6 to 9 GHz. The Fo and 3Fo isolations are 15 dBc with respect to output signal level. This frequency multiplier features DC blocked I/O's, and is ideal for use in LO multiplier chains for Pt to Pt & VSAT Radios yielding reduced parts count vs. traditional approaches. The low additive SSB Phase Noise of -140 dBc/Hz at 100 kHz offset helps maintain good system noise performance. The HMC575LP4 & HMC575LP4E are compatible with surface mount manufacturing techniques.

Electrical Specifications, $T_A = +25^\circ \text{C}$, $V_{dd1}, V_{dd2} = +5\text{V}$, 3 dBm Drive Level

Parameter	Min.	Typ.	Max.	Units
Frequency Range, Input	3 - 4.5			GHz
Frequency Range, Output	6 - 9			GHz
Output Power	14	17		dBm
Fo Isolation (with respect to output level)		15		dBc
3Fo Isolation (with respect to output level)		15		dBc
Input Return Loss		15		dB
Output Return Loss		12		dB
SSB Phase Noise (100 kHz Offset)		-140		dBc/Hz
Supply Current (I _{dd1} & I _{dd2})		90		mA



HMC575LP4 / 575LP4E

SMT GaAs MMIC x2 ACTIVE FREQUENCY MULTIPLIER, 6 - 9 GHz OUTPUT

Output Power vs. Temperature @ 3 dBm Drive Level

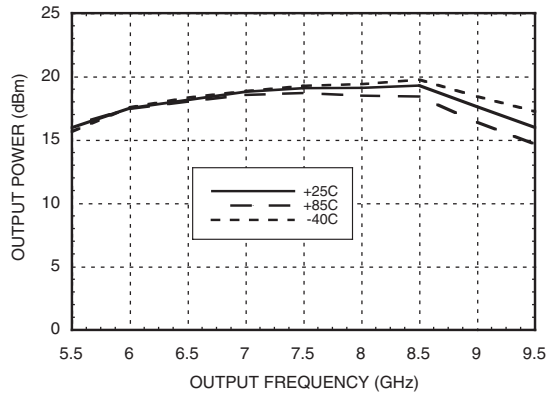

Output Power vs. Drive Level

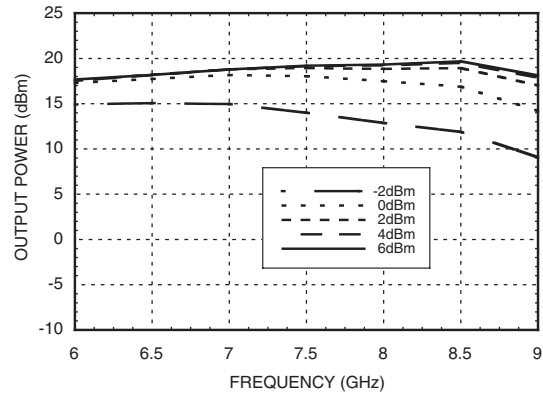

Output Power vs. Supply Voltage @ 3 dBm Drive Level

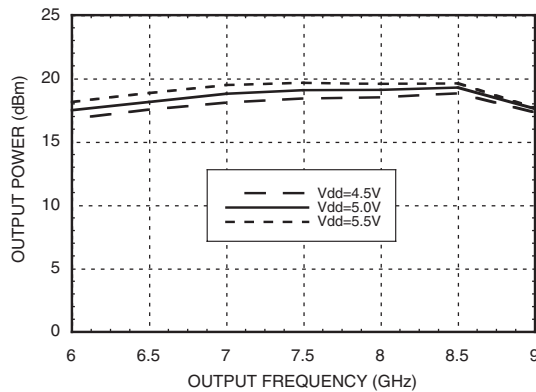

Isolation @ 3 dBm Drive Level

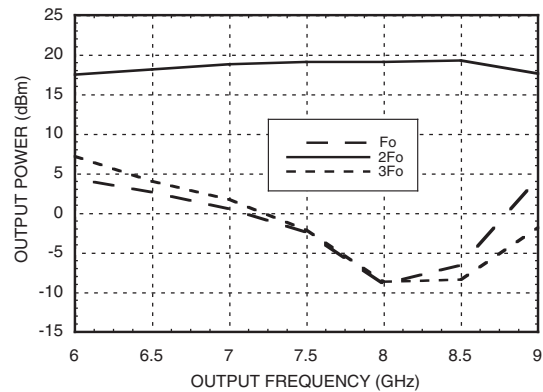

Output Power vs. Input Power

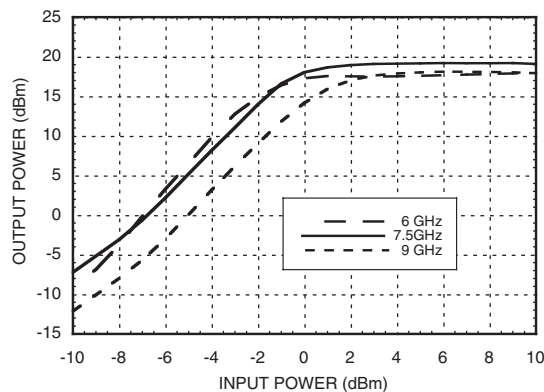

HMC575LP4 / 575LP4E

SMT GaAs MMIC x2 ACTIVE FREQUENCY MULTIPLIER, 6 - 9 GHz OUTPUT

Input Return Loss vs. Temperature

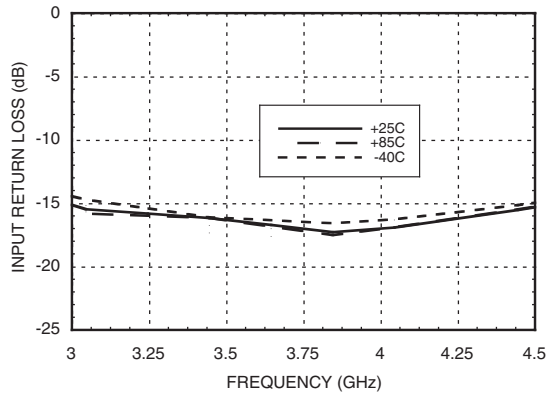

Output Return Loss vs. Temperature

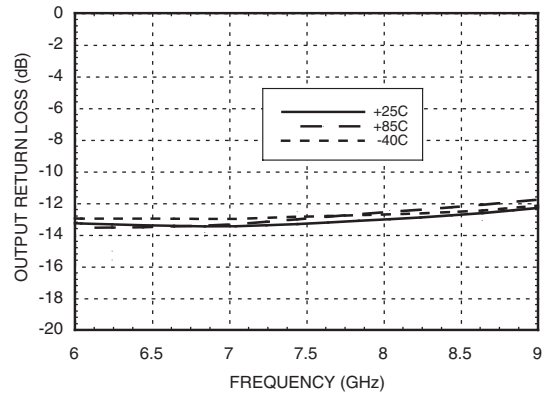

Absolute Maximum Ratings

RF Input (Vdd = +5V)	+13 dBm
Supply Voltage (Vdd)	+6.0 Vdc
Channel Temperature	150 °C
Continuous P _{diss} (T= 85 °C) (derate 7.9 mW/°C above 85 °C)	512 mW
Thermal Resistance (channel to ground paddle)	127 °C/W
Storage Temperature	-65 to +150 °C
Operating Temperature	-40 to +85 °C

Typical Supply Current vs. Vdd

Vdd (Vdc)	I _{dd} (mA)
4.5	89
5.0	90
5.5	91

Note:
Multiplier will operate over full voltage range shown above.



ELECTROSTATIC SENSITIVE DEVICE
OBSERVE HANDLING PRECAUTIONS

Outline Drawing

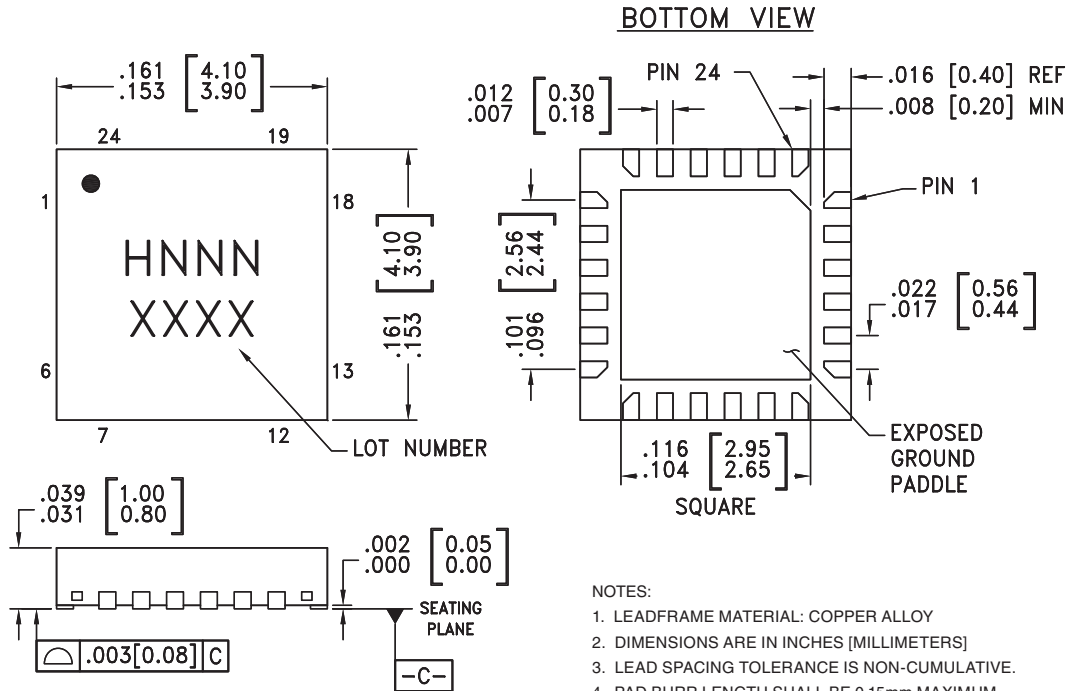

Package Information

Part Number	Package Body Material	Lead Finish	MSL Rating	Package Marking ^[3]
HMC575LP4	Low Stress Injection Molded Plastic	Sn/Pb Solder	MSL1 ^[1]	H575 XXXX
HMC575LP4E	RoHS-compliant Low Stress Injection Molded Plastic	100% matte Sn	MSL1 ^[2]	H575 XXXX

[1] Max peak reflow temperature of 235 °C

[2] Max peak reflow temperature of 260 °C

[3] 4-Digit lot number XXXX



v00.0506

HMC575LP4 / 575LP4E

SMT GaAs MMIC x2 ACTIVE FREQUENCY MULTIPLIER, 6 - 9 GHz OUTPUT



Pin Description

Pin Number	Function	Description	Interface Schematic
1, 5 - 14, 18, 19, 21, 23, 24	N/C	These pins are internally not connected; however, this product was specified with these pins connected to RF/ DC ground.	
2, 4, 15, 17	GND	Package bottom must also be connected to RF/DC ground.	
3	RFIN	Pin is AC coupled and matched to 50 Ohms from 3 - 4.5 GHz.	
16	RFOUT	Pin is AC coupled and matched to 50 Ohms from 6 - 9 GHz.	
20, 22	Vdd2, Vdd1	Supply voltage 5V ± 0.5V. External bypass capacitors of 100 pF and 2.2 μF are required.	

Application Circuit

Component	Value
C1, C2	100 pF
C3, C4	2.2 μF

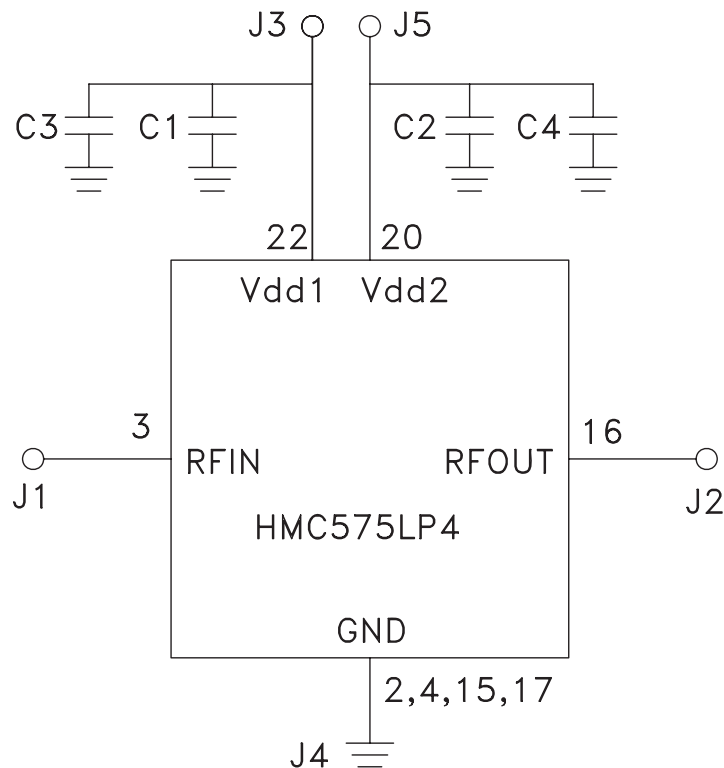

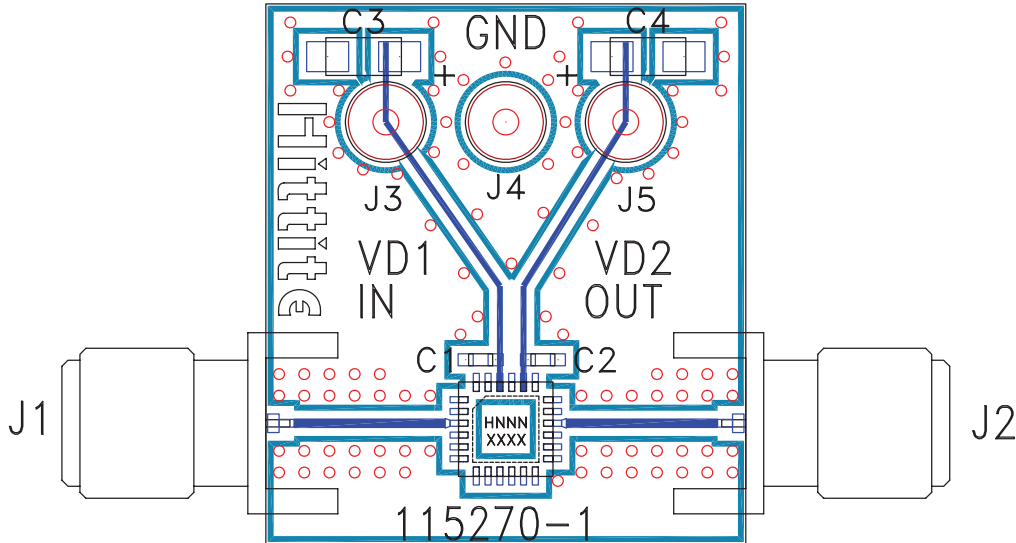
Evaluation PCB

List of Materials for Evaluation PCB 112405 [1]

Item	Description
J1, J2	PCB Mount SRI SMA Connector
J3 - J5	DC Pin
C1, C2	100 pF Capacitor, 0402 Pkg.
C3, C4	2.2 μ F Tantalum Capacitor
U1	HMC575LP4 / HMC575LP4E x2 Active Multiplier
PCB [2]	115270 Eval Board

[1] Reference this number when ordering complete evaluation PCB

[2] Circuit Board Material: Rogers 4350

The circuit board used in the final application should be generated with proper RF circuit design techniques. Signal lines should have 50 ohm impedance while the package ground leads and exposed paddle should be connected directly to the ground plane similar to that shown. The evaluation circuit board shown is available from Hittite upon request.