

Integrated Compass Sensor HMC6052

Preliminary Information

The Honeywell HMC6052 is a 2-axis Magneto-Resistive sensor plus amplifiers and analog support features essential for compassing and low magnetic field sensing. The product is offered in a 14-pin surface mount 3.5mm by 3.5mm LCC package. Two channels of amplified sensor signals with a set switch function allow compass system designers to have a compact, easy to implement solution. Applications for the HMC6052 include electronic compassing, and magnetometry.

Honeywell continues to maintain product excellence and performance by introducing innovative solid-state magnetic sensor solutions. These are highly reliable, top performance products that are delivered when promised. Honeywell's magnetic sensor products provide real solutions you can count on.

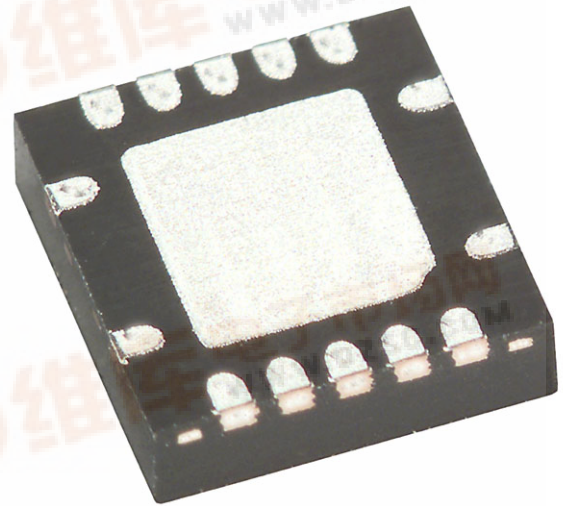

FEATURES

- ▶ 2 Axis AMR Magnetic Sensor (HMC1052) w/ Integrated Amplifiers & Set Circuit
- ▶ Single Die in a Surface Mount Package (3.5 x 3.5 x 0.8 mm 14-pin LCC)
- ▶ Minimal Support Components
- ▶ Field Range +/- 2 gauss
- ▶ Low Voltage Operation (2.5 to 3.6 V)
- ▶ Precision Magnetic Field Measurement
- ▶ Minimal Detectable Field (80 micro-gauss)
- ▶ Lead Free Package Construction

BENEFITS

- ▶ Complete Analog Solution Optimized for Compassing. Eliminates Need for External Amplifiers and Most Discrete Components
- ▶ Optimized for Smallest Footprint and Easy Integration
- ▶ Only Two Capacitors to Complete the Analog Signal Processing
- ▶ Optimized for Compass Applications in Hand-Held or Hard Iron Environment
- ▶ Compatible for Battery Powered Applications
- ▶ User's ADC Resolution Limits the Accuracy of the Outputs
- ▶ Permits Accurate Compassing and Magnetic Field Measurement
- ▶ Complies with Current Environmental Standards (RoHS)

HMC6052 SPECIFICATIONS

Characteristics	Conditions*	Min	Typ	Max	Units
Supply Voltage	Vsupply, Vbridge to GND	2.5	3.0	3.6	Volts
Supply Current	Vsupply to GND			9	mA
Bridge Current	A, B bridges		6		mA
Field Range	Full scale (FS), Vsupply, Vbridge = 3.0 volts	-2.0		+2.0	gauss
Field Sensitivity	Vsupply, Vbridge = 3.0 volts		0.5		V/gauss
Zero Field Output	Vsupply, Vbridge = 3.0 volts		1.5		volts
Load Resistance	Applied to OUTA, OUTB	6000	10,000	-	ohms
Load Capacitance	Applied to OUTA, OUTB	-		100	pF
Bandwidth	system signal output (lower limit = DC)	1			kHz
Noise Floor	Vsupply, Vbridge = 3.0V SINL, SINH toggle before measurement		1		mV
Linearity	Vsupply, Vbridge=3.0V, Field +/- 0.5 Oe		0.4		%FS
Disturbing Field	Sensitivity starts to degrade. Use set pulse to restore sensitivity.	20			Gauss
Max. Exposed Field	No perming effect on zero field reading			10000	Gauss
Operating Temperature	Ambient	-45		120	°C
Storage Temperature	Ambient, Unbiased	-55		150	°C
Sensitivity Tempco		-3000	-2700	-2400	ppm/°C
Output Voltage Tempco			± 500		ppm/°C
Sensitivity Ratio of Sensors	T _A = 0 to 70°C	95	100	105	%
X,Y sensor Orthogonality	Sensitive direction in X and Y sensors			0.01	Degree

* Tested at 25°C except stated otherwise.

Characteristics	Conditions*	Min	Typ	Max	Units
-----------------	-------------	-----	-----	-----	-------

Set Strap Circuit

Input Logic Voltage	Measured from SIN to GND (Vsupply = 3.0v)				
	Low "0" State		0.3		volts
	High "1" State		2.5		volts
Input Logic Current			0		μA

Offset Straps

Resistance	Measured from OFF+ to OFF-	12	15	18	ohms
Offset Constant	DC Current Field applied in sensitive directions		10		mA/gauss
Resistance Tempco	T _A = 0 to 70°C	3500	3900	4300	ppm/°C

* Tested at 25°C except stated otherwise.

Pin Configurations

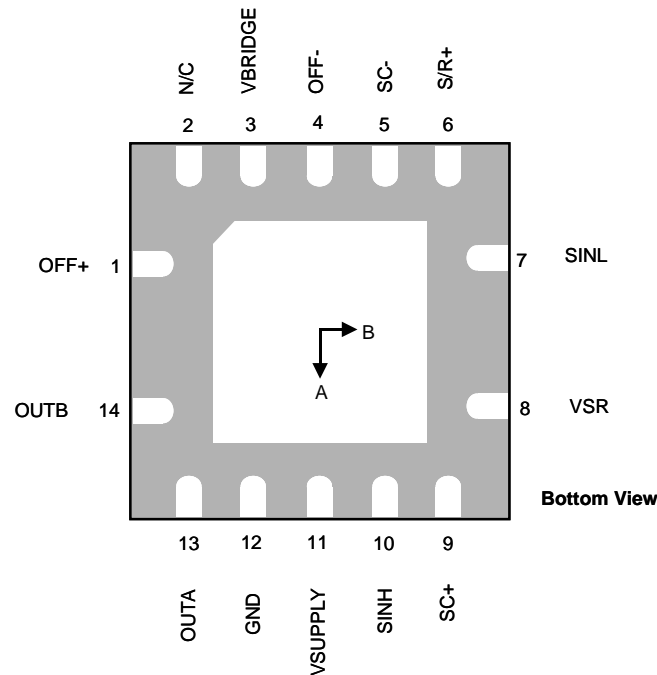

Pin Descriptions

HMC6052

Pin	Name	Description
1	OFF+	Offset Strap Positive
2	N/C	No Connect
3	VBRIDGE	Positive Voltage Supply (2.7 to 3.6 volts) to Sensor Bridges
4	OFF-	Offset Strap Negative
5	SC-	Set Strap Capacitor Negative
6	S/R+	Set/Reset Strap Positive (test point)
7	SINL	Set Strap Logic Input (normally low)
8	VSR	Set Strap Reservoir Capacitor
9	SC+	Set Strap Capacitor Positive
10	SINH	Set Strap Logic Input (normally high)
11	VSUPPLY	Positive Voltage Supply (2.7 to 3.6 volts) to Signal Conditioning
12	GND	Negative Voltage Supply and Signal Ground Reference
13	OUTA	Output Voltage for Sensor A
14	OUTB	Output Voltage for Sensor B

Package Dimensions

Symbol	Millimeters		
	Min	Nom	Max
A	0.80	0.90	1.00
A1	0	0.02	0.05
A3	0.20 BSC		
b	0.18	0.23	0.30
D	3.50 BSC		
D2	1.90	2.05	2.15
E	3.50 BSC		
E2	1.90	2.05	2.15
e	0.50 BSC		
L	0.30	0.40	0.50
N		14	
ND		5	
NE		2	
r	b(min)/2		
aaa		0.15	
bbb		0.10	
ccc		0.10	

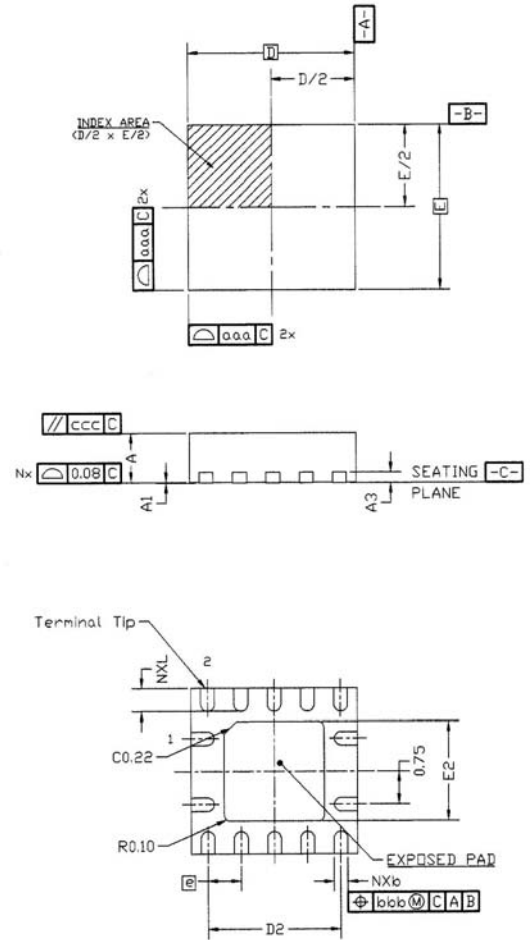

Mounting Considerations

Stencil Design and Solder Paste

A 4 mil stencil and 100% paste coverage is recommended electrical contact pads. The HMC6052 has been tested successfully with no-clean solder paste.

Pick and Place

Placement is machine dependant and no restrictions are recommended, and have been tested with mechanical centering. Placement force should be equivalent 1206 SMT components.

Reflow and Rework

No special profile is required for the HMC6052 and compatible with lead eutectic and lead-free solder paste reflow profiles. Honeywell recommends the adherence to solder paste manufacturer’s guidelines. Irons with a tip temperature no greater than 315°C should be used.

Application Notes

The HMC6052 Integrated Compass Sensor circuit is composed of two Magneto-Resistive (MR) sensors that sense external magnetic fields and additional analog support circuits for electronic compass functions. Two instrumentation amplifiers follow the sensor wheatstone bridges to measure the differential output signals and provide substantial voltage amplification. A voltage reference is used to center the amplifiers for common zero field bias point. A pair of electronic switch circuits is included, to create a set pulse function using an external capacitor connected to the SC- and SC+ pins. In a quiescent state, the capacitor will be charged to the full supply voltage potential and suddenly discharged in reverse polarity when both SINL and SINH pins flip logic states. The resulting set pulse current flows through the set strap near the sensor bridge re-aligning the magnetic moments on the bridge magneto-resistive elements. This toggling of the set strap circuit is on user demand, or periodically to remove any potential magnetic upsets to the sensors.

Reference Design

The schematic diagram in Figure 1 shows the basic HMC6052 application circuit with a minimum of external components.

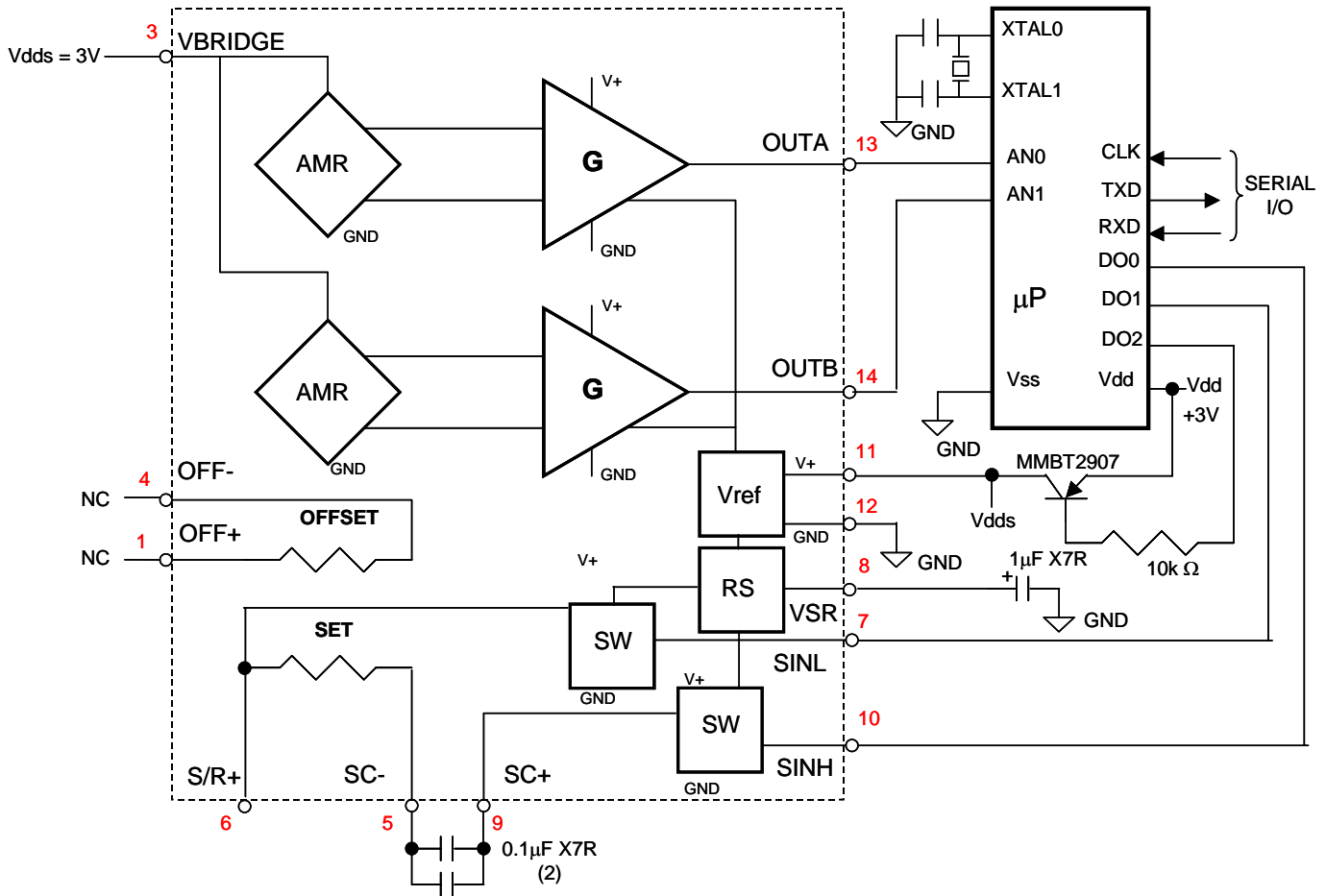

Figure 1

From Figure 1, the host microprocessor (μP) controls the HMC6052 via digital output port lines DO0 through DO2. The first digital control line (DO0) is normally in a high logic state and briefly pulls down to drive the high-side switch connected to pin 10 (SINH) of the HMC6052. Likewise, DO1 is a reverse logic control line that is normally low and pulls high briefly to drive the low-side switch at pin 7 (SINL) of the HMC6052. Together DO0 and DO1 toggle states to create a “set” pulse through the internal set strap resistance that spirals through the sensor bridge elements. This set pulse creates an intense magnetic field that will re-align the magnetic domains of the magneto-resistive elements to undo the effects of thermal agitation, and any magnetic upset events that might “disturb” the sensors. The frequency of the toggling is the designer’s choice, but typically ranges from once per second to once per day. The external set strap capacitance across pins 5 (SC-) and 9 (SC+) is to be around 0.2µf to 1µf in value, with emphasis on keeping the total capacitor ESR (effective series resistance) below 0.5 ohms to minimize capacitor internal losses while delivering a current spike in excess of 0.5 amperes.

The microprocessor also has control of the complete power supplied to the HMC6052 via digital control line DO2 that switches the MMBT2907 bipolar junction transistor, to connect the 3.0-volt system supply voltage to the sensor circuits. By pulling low DO2, the transistor saturates to connect Vdd to Vdds, which are the switched supply connections to VSUPPLY (pin 11) and VBRIDGE (pin 3). With power applied, the HMC6052 internal circuits quickly stabilize to provide accurate magnetic vector voltages at output pins 13 (OUTA) and 14 (OUTB). With near zero magnetic field inputs, OUTA and OUTB should be near half the supply voltage to provide bipolar output voltage values corresponding to the intensity and polarity of the resulting magnetic fields on the sensor bridges. Zero field stimulus to the HMC6052 can be obtained using magnetic shielded containers, or helmholtz coil sets.

Toggling the DO2 digital control line is necessary in many applications to reduce the total system current consumption when not taking magnetic field measurements to preserve battery energy reserves. Up to 15mA can be drawn from the

HMC6052



supply during the sensor circuit's operation. The supply current can be effectively reduced by "duty cycling" DO2 and making "snapshot" measurements during the sensor's on time.

For example, a 3.0-volt lithium watch battery may have a typical 150mA-hour energy capacity rating. With the reference design drawing about 15mA continuously, only 10 hours of operational time results. By placing the microcontroller and HMC6052 into sleep mode 99% of the time, the total battery life extends to 1000 hours. Even greater efficiencies can be had if the host microprocessor only toggles on DO2 for a few milliseconds, makes the analog to digital conversions of outputs OUTA and OUTB, and then pulls DO2 high to sleep the HMC6052 until the next required measurement update.

The analog outputs of the HMC6052 circuit (OUTA, OUTB) are representative voltages proportional to the magnetic field imposed on sensor bridges A and B. The sensor bridges have orthogonal axis of sensitivity and create a two dimensional representation of the magnetic field's strength and direction. When oriented nearly level with the ground, the outputs can then be used for electronic compassing by sensing the horizontal components of the earth's magnetic field. Using onboard Analog-to-Digital Converters (ADCs) within the host microprocessor, the digital representations of north-pole magnetic field direction can be related to the host platform (watch, phone, PDA, vehicle, ship, aircraft, etc.).

The outputs of the HMC6052 are referenced to approximately half of the supply voltage applied across pins 11 (VSUPPLY) and 12 (GND). With no other errors accounted for, OUTA (pin 13) and OUTB (pin 14) would be close to 1.5 volts with no magnetic field applied (completely shielded) and a supply voltage of 3-volts. If the shielding were removed and a nominal earth's magnetic field applied of 300 milli-gauss and -100 milli-gauss to sensor bridges A and B respectively, OUTA would move positively from 1.5 volts and OUTB would move negatively from 1.5 volts. Neglecting offset errors and using a nominal sensitivity of 0.5 volts per gauss, OUTA would be at about 1.65 volts and OUTB would be at about 1.45 volts.

Using the above example values of earth's field excitation, a host microprocessor with onboard 10-bit ADCs could provide 1024 increments (or counts) across the nominal zero to 3-volt supply voltage. If count 512 (about 1.5 volts) is referenced as the zero gauss point, the 1.65 and 1.45 volt OUTA and OUTB levels convert to counts 563 and 495 respectively. Without compensating for offset errors and calibration factors, the magnetic vectors for outputs A and B would be 51 and -17 counts with respect to the zero field level count. In electronic compassing, the arctangent (B/A) is computed by the microprocessor, resulting in a heading of about 341 degrees (19 degrees west of magnetic north).

For details on offset correction, calibration, and electronic compass heading computation using microprocessors, please visit www.magneticsensors.com, and browse the technical papers and application notes in the applications section.

ORDERING INFORMATION

Ordering Number	Product
HMC6052	Integrated Compass Sensor

Find out more

For more information on Honeywell's Magnetic Sensors visit us online at www.magneticsensors.com or contact us at 800-323-8295 (763-954-2474 internationally).

The application circuits herein constitute typical usage and interface of Honeywell product. Honeywell does not warranty or assume liability of customer-designed circuits derived from this description or depiction.

Honeywell reserves the right to make changes to improve reliability, function or design. Honeywell does not assume any liability arising out of the application or use of any product or circuit described herein; neither does it convey any license under its patent rights nor the rights of others.

U.S. Patents 4,441,072, 4,533,872, 4,569,742, 4,681,812, 4,847,584 and 6,529,114 apply to the technology described

