HM5116405 Series HM5117405 Series

16 M EDO DRAM (4-Mword × 4-bit)
4 k Refresh/2 k Refresh

HITACHI

ADE-203-633D (Z)
Rev. 4.0
Nov. 1997

Description

The Hitachi HM5116405 Series, HM5117405 Series are CMOS dynamic RAMs organized 4,194,304-word × 4-bit. They employ the most advanced CMOS technology for high performance and low power. The HM5116405 Series, HM5117405 Series offer Extended Data Out (EDO) Page Mode as a high speed access mode. They have package variations of standard 26-pin plastic SOJ and standard 26-pin plastic TSOP II.

Features

- Single 5 V (±10%)
- Access time: 50 ns/60 ns/70 ns (max)
- Power dissipation
 - Active mode : 495 mW/440 mW/385 mW (max) (HM5116405 Series)
: 550 mW/495 mW/440 mW (max) (HM5117405 Series)
 - Standby mode : 11 mW (max)
: 0.83 mW (max) (L-version)
- EDO page mode capability
- Long refresh period
 - 4096 refresh cycles : 64 ms (HM5116405 Series)
: 128 ms (L-version)
 - 2048 refresh cycles : 32 ms (HM5117405 Series)
: 128 ms (L-version)
- 3 variations of refresh
 - RAS-only refresh
 - CAS-before-RAS refresh
 - Hidden refresh

HM5116405 Series, HM5117405 Series

- Battery backup operation (L-version)
- Test function
 - 16-bit parallel test mode

Ordering Information

Type No.	Access time	Package
HM5116405S-5	50 ns	300-mil 26-pin plastic SOJ (CP-26/24DB)
HM5116405S-6	60 ns	
HM5116405S-7	70 ns	
HM5116405LS-5	50 ns	
HM5116405LS-6	60 ns	
HM5116405LS-7	70 ns	
HM5117405S-5	50 ns	
HM5117405S-6	60 ns	
HM5117405S-7	70 ns	
HM5117405LS-5	50 ns	
HM5117405LS-6	60 ns	
HM5117405LS-7	70 ns	
HM5116405TS-5	50 ns	300-mil 26-pin plastic TSOP II (TTP-26/24DA)
HM5116405TS-6	60 ns	
HM5116405TS-7	70 ns	
HM5116405LTS-5	50 ns	
HM5116405LTS-6	60 ns	
HM5116405LTS-7	70 ns	
HM5117405TS-5	50 ns	
HM5117405TS-6	60 ns	
HM5117405TS-7	70 ns	
HM5117405LTS-5	50 ns	
HM5117405LTS-6	60 ns	
HM5117405LTS-7	70 ns	

HM5116405 Series, HM5117405 Series

Pin Arrangement

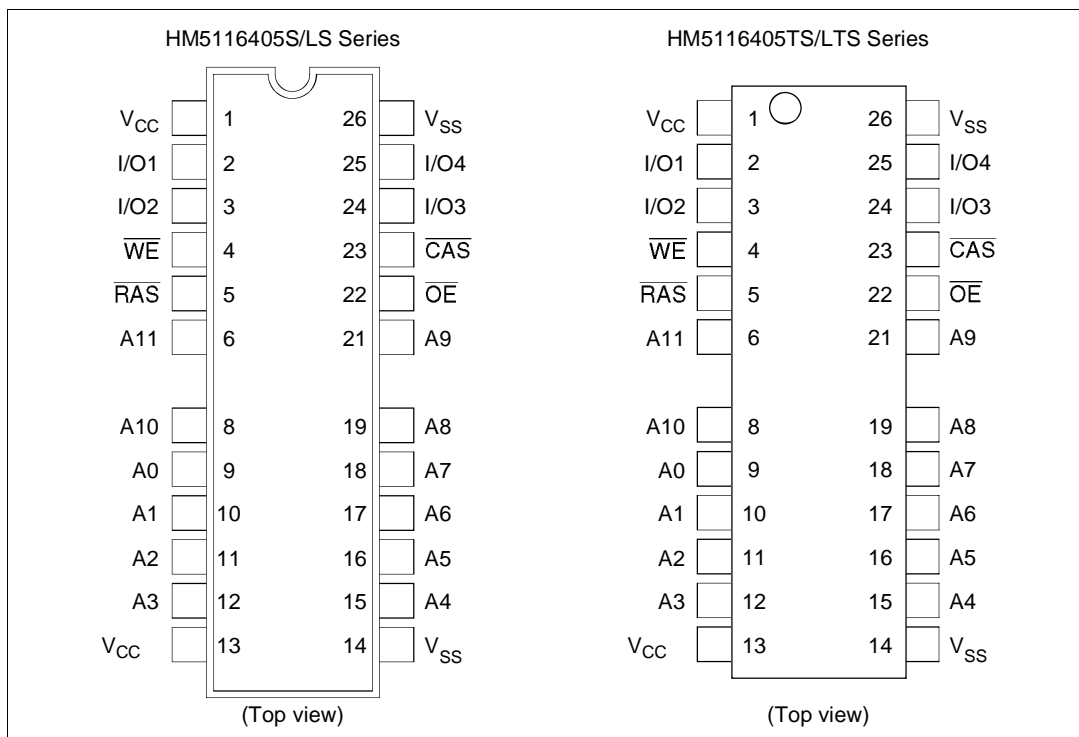

Pin Description

Pin name	Function
A0 to A11	Address input <ul style="list-style-type: none"> • Row/Refresh address A0 to A11 • Column address A0 to A9
I/O1 to I/O4	Data input/Data output
\overline{RAS}	Row address strobe
\overline{CAS}	Column address strobe
\overline{WE}	Write enable
\overline{OE}	Output enable
V _{CC}	Power supply
V _{SS}	Ground

HM5116405 Series, HM5117405 Series

Pin Arrangement

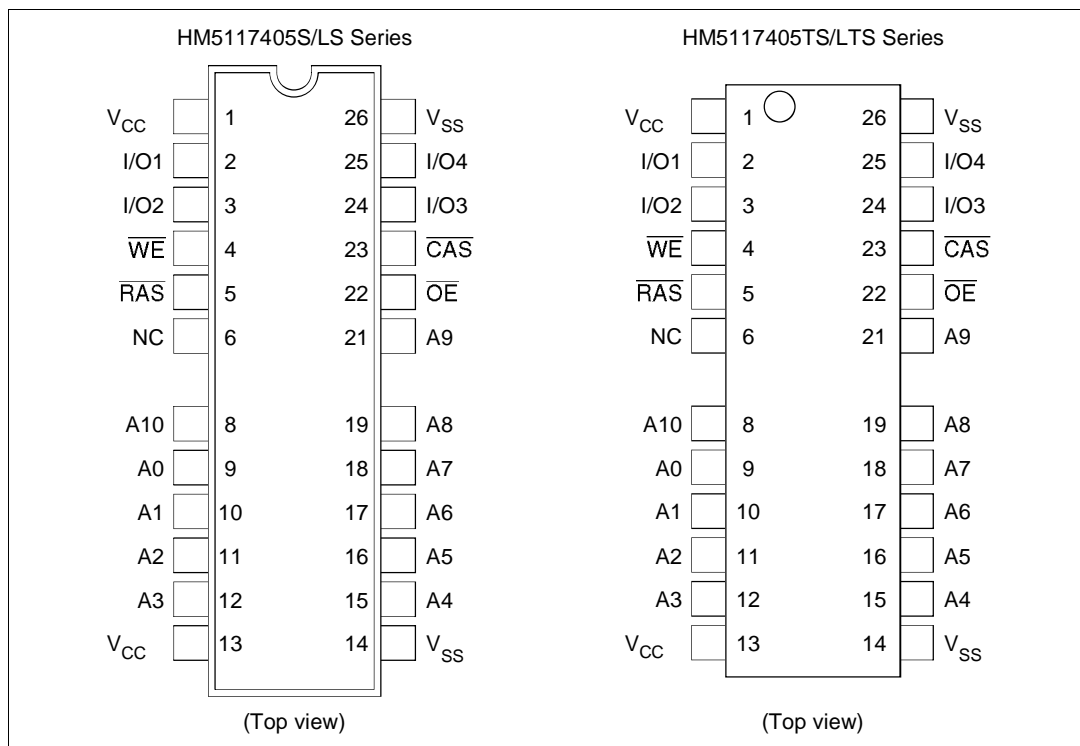

Pin Description

Pin name	Function
A0 to A10	Address input <ul style="list-style-type: none"> • Row/Refresh address A0 to A10 • Column address A0 to A10
I/O1 to I/O4	Data input/Data output
RAS	Row address strobe
CAS	Column address strobe
\overline{WE}	Write enable
\overline{OE}	Output enable
V _{CC}	Power supply
V _{SS}	Ground
NC	No connection

HM5116405 Series, HM5117405 Series

Block Diagram (HM5116405 Series)

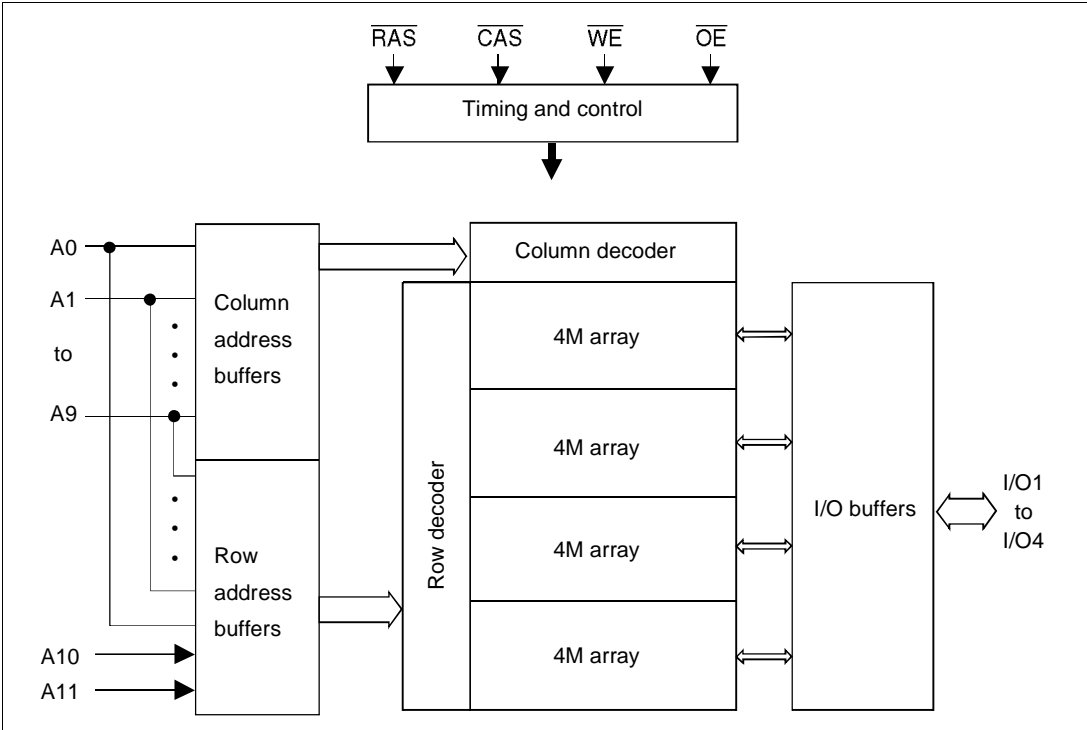

HM5116405 Series, HM5117405 Series

Block Diagram (HM5117405 Series)

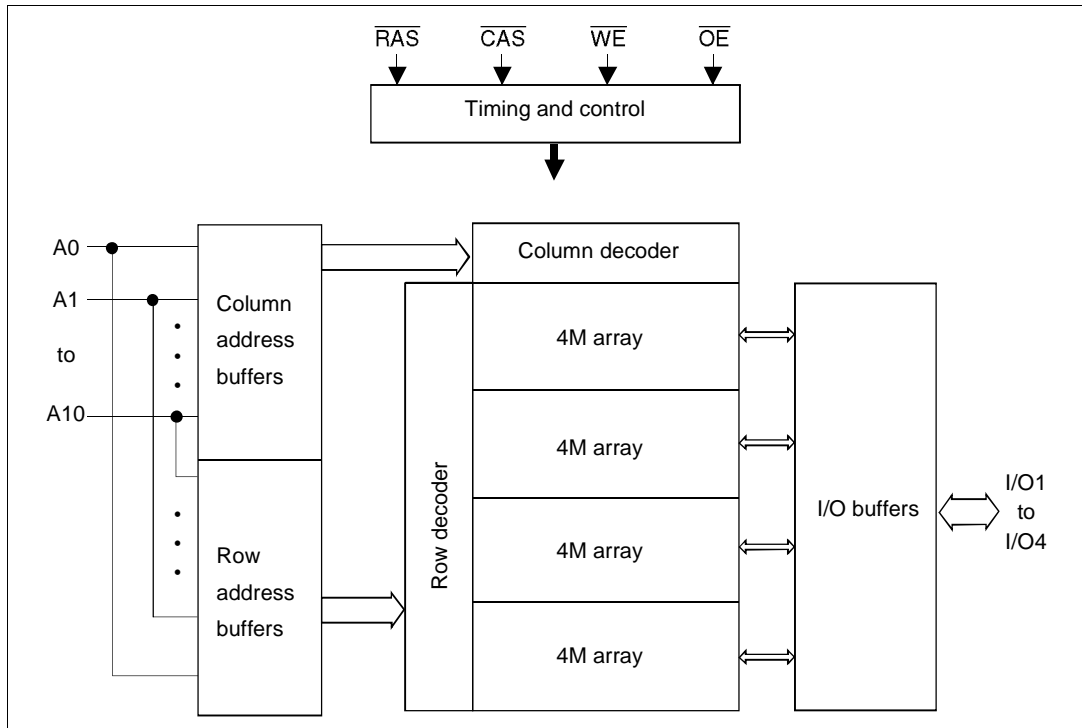

HM5116405 Series, HM5117405 Series

Absolute Maximum Ratings

Parameter	Symbol	Value	Unit
Voltage on any pin relative to V_{SS}	V_T	-1.0 to +7.0	V
Supply voltage relative to V_{SS}	V_{CC}	-1.0 to +7.0	V
Short circuit output current	I_{out}	50	mA
Power dissipation	P_T	1.0	W
Operating temperature	T_{opr}	0 to +70	°C
Storage temperature	T_{stg}	-55 to +125	°C

Recommended DC Operating Conditions ($T_a = 0$ to +70°C)

Parameter	Symbol	Min	Typ	Max	Unit	Note
Supply voltage	V_{CC}	4.5	5.0	5.5	V	1
Input high voltage	V_{IH}	2.4	—	6.5	V	1
Input low voltage	V_{IL}	-1.0	—	0.8	V	1

Note: 1. All voltage referred to V_{SS} .

HM5116405 Series, HM5117405 Series

DC Characteristics

(Ta = 0 to +70°C, V_{CC} = 5 V ± 10%, V_{SS} = 0 V) (HM5116405 Series)

Parameter	Symbol	HM5116405						Unit	Test conditions
		-5		-6		-7			
		Min	Max	Min	Max	Min	Max		
Operating current ^{*1, *2}	I _{CC1}	—	90	—	80	—	70	mA	t _{RC} = min
Standby current	I _{CC2}	—	2	—	2	—	2	mA	TTL interface R _{AS} , C _{AS} = V _{IH} Dout = High-Z
		—	1	—	1	—	1	mA	CMOS interface R _{AS} , C _{AS} ≥ V _{CC} - 0.2 V Dout = High-Z
Standby current (L-version)	I _{CC2}	—	150	—	150	—	150	μA	CMOS interface R _{AS} , C _{AS} ≥ V _{CC} - 0.2 V Dout = High-Z
RAS-only refresh current ^{*2}	I _{CC3}	—	90	—	80	—	70	mA	t _{RC} = min
Standby current ^{*1}	I _{CC5}	—	5	—	5	—	5	mA	R _{AS} = V _{IH} C _{AS} = V _{IL} Dout = enable
CAS-before-RAS refresh current	I _{CC6}	—	90	—	80	—	70	mA	t _{RC} = min
EDO page mode current ^{*1, *3}	I _{CC7}	—	80	—	70	—	65	mA	t _{HPC} = min
Battery backup current	I _{CC10}	—	350	—	350	—	350	μA	CMOS interface Dout = High-Z, CBR refresh: t _{RC} = 31.3 μs t _{RAS} ≤ 0.3 μs
Input leakage current	I _{LI}	-10	10	-10	10	-10	10	μA	0 V ≤ Vin ≤ 7 V
Output leakage current	I _{LO}	-10	10	-10	10	-10	10	μA	0 V ≤ Vin ≤ 7 V Dout = disable
Output high voltage	V _{OH}	2.4	V _{CC}	2.4	V _{CC}	2.4	V _{CC}	V	High Iout = -2 mA
Output low voltage	V _{OL}	0	0.4	0	0.4	0	0.4	V	Low Iout = 2 mA

Notes : 1. I_{CC} depends on output load condition when the device is selected. I_{CC} max is specified at the output open condition.

2. Address can be changed once or less while R_{AS} = V_{IL}.

3. Address can be changed once or less while C_{AS} = V_{IH}.

HM5116405 Series, HM5117405 Series

DC Characteristics

($T_a = 0$ to $+70^\circ\text{C}$, $V_{CC} = 5\text{ V} \pm 10\%$, $V_{SS} = 0\text{ V}$) (HM5117405 Series)

Parameter	Symbol	HM5117405						Unit	Test conditions
		-5		-6		-7			
		Min	Max	Min	Max	Min	Max		
Operating current ^{*1, *2}	I_{CC1}	—	100	—	90	—	80	mA	$t_{RC} = \text{min}$
Standby current	I_{CC2}	—	2	—	2	—	2	mA	TTL interface $\overline{\text{RAS}}, \overline{\text{CAS}} = V_{IH}$ Dout = High-Z
		—	1	—	1	—	1	mA	CMOS interface $\overline{\text{RAS}}, \overline{\text{CAS}} \geq V_{CC} - 0.2\text{ V}$ Dout = High-Z
Standby current (L-version)	I_{CC2}	—	150	—	150	—	150	μA	CMOS interface $\overline{\text{RAS}}, \overline{\text{CAS}} \geq V_{CC} - 0.2\text{ V}$ Dout = High-Z
RAS-only refresh current ^{*2}	I_{CC3}	—	100	—	90	—	80	mA	$t_{RC} = \text{min}$
Standby current ^{*1}	I_{CC5}	—	5	—	5	—	5	mA	$\overline{\text{RAS}} = V_{IH}$ $\overline{\text{CAS}} = V_{IL}$ Dout = enable
$\overline{\text{CAS}}$ -before- $\overline{\text{RAS}}$ refresh current	I_{CC6}	—	100	—	90	—	80	mA	$t_{RC} = \text{min}$
EDO page mode current ^{*1, *3}	I_{CC7}	—	90	—	80	—	75	mA	$t_{HPC} = \text{min}$
Battery backup current	I_{CC10}	—	350	—	350	—	350	μA	CMOS interface Dout = High-Z, CBR refresh: $t_{RC} = 62.5\ \mu\text{s}$ $t_{RAS} \leq 0.3\ \mu\text{s}$
Input leakage current	I_{LI}	-10	10	-10	10	-10	10	μA	$0\text{ V} \leq V_{in} \leq 7\text{ V}$
Output leakage current	I_{LO}	-10	10	-10	10	-10	10	μA	$0\text{ V} \leq V_{in} \leq 7\text{ V}$ Dout = disable
Output high voltage	V_{OH}	2.4	V_{CC}	2.4	V_{CC}	2.4	V_{CC}	V	High Iout = -2 mA
Output low voltage	V_{OL}	0	0.4	0	0.4	0	0.4	V	Low Iout = 2 mA

Notes : 1. I_{CC} depends on output load condition when the device is selected. I_{CC} max is specified at the output open condition.

2. Address can be changed once or less while $\overline{\text{RAS}} = V_{IL}$.

3. Address can be changed once or less while $\overline{\text{CAS}} = V_{IH}$.

HM5116405 Series, HM5117405 Series

Capacitance ($T_a = 25^\circ\text{C}$, $V_{CC} = 5\text{ V} \pm 10\%$)

Parameter	Symbol	Typ	Max	Unit	Notes
Input capacitance (Address)	C_{i1}	—	5	pF	1
Input capacitance (Clocks)	C_{i2}	—	7	pF	1
Output capacitance (Data-in, Data-out)	$C_{i/O}$	—	7	pF	1, 2

Notes : 1. Capacitance measured with Boonton Meter or effective capacitance measuring method.

2. $\overline{\text{CAS}} = V_{IH}$ to disable Dout.

HM5116405 Series, HM5117405 Series

AC Characteristics ($T_a = 0$ to $+70^\circ\text{C}$, $V_{CC} = 5\text{ V} \pm 10\%$, $V_{SS} = 0\text{ V}$) *¹, *², *¹⁸

Test Conditions

- Input rise and fall time: 2 ns
- Input levels: $V_{IL} = 0\text{ V}$, $V_{IH} = 3\text{ V}$
- Input timing reference levels: 0.8 V, 2.4 V
- Output timing reference levels: 0.8 V, 2.0 V
- Output load: 1 TTL gate + C_L (100 pF) (Including scope and jig)

Read, Write, Read-Modify-Write and Refresh Cycles (Common parameters)

		HM5116405/HM5117405							
		-5		-6		-7			
Parameter	Symbol	Min	Max	Min	Max	Min	Max	Unit	Notes
Random read or write cycle time	t_{RC}	84	—	104	—	124	—	ns	
$\overline{\text{RAS}}$ precharge time	t_{RP}	30	—	40	—	50	—	ns	
$\overline{\text{CAS}}$ precharge time	t_{CP}	7	—	10	—	13	—	ns	
$\overline{\text{RAS}}$ pulse width	t_{RAS}	50	10000	60	10000	70	10000	ns	
$\overline{\text{CAS}}$ pulse width	t_{CAS}	7	10000	10	10000	13	10000	ns	
Row address setup time	t_{ASR}	0	—	0	—	0	—	ns	
Row address hold time	t_{RAH}	7	—	10	—	10	—	ns	
Column address setup time	t_{ASC}	0	—	0	—	0	—	ns	
Column address hold time	t_{CAH}	7	—	10	—	13	—	ns	
$\overline{\text{RAS}}$ to $\overline{\text{CAS}}$ delay time	t_{RCD}	11	37	14	45	14	52	ns	3
$\overline{\text{RAS}}$ to column address delay time	t_{RAD}	9	25	12	30	12	35	ns	4
$\overline{\text{RAS}}$ hold time	t_{RSH}	10	—	13	—	13	—	ns	
$\overline{\text{CAS}}$ hold time	t_{CSH}	35	—	40	—	45	—	ns	
$\overline{\text{CAS}}$ to $\overline{\text{RAS}}$ precharge time	t_{CRP}	5	—	5	—	5	—	ns	
$\overline{\text{OE}}$ to Din delay time	t_{OED}	13	—	15	—	18	—	ns	5
$\overline{\text{OE}}$ delay time from Din	t_{DZO}	0	—	0	—	0	—	ns	6
$\overline{\text{CAS}}$ delay time from Din	t_{DZC}	0	—	0	—	0	—	ns	6
Transition time (rise and fall)	t_T	2	50	2	50	2	50	ns	7

HM5116405 Series, HM5117405 Series

Read Cycle

Parameter	Symbol	HM5116405/HM5117405						Unit	Notes
		-5		-6		-7			
		Min	Max	Min	Max	Min	Max		
Access time from $\overline{\text{RAS}}$	t_{RAC}	—	50	—	60	—	70	ns	8, 9, 20
Access time from $\overline{\text{CAS}}$	t_{CAC}	—	13	—	15	—	18	ns	9, 10, 17, 20
Access time from address	t_{AA}	—	25	—	30	—	35	ns	9, 11, 17, 20
Access time from $\overline{\text{OE}}$	t_{OEA}	—	13	—	15	—	18	ns	9, 20
Read command setup time	t_{RCS}	0	—	0	—	0	—	ns	
Read command hold time to $\overline{\text{CAS}}$	t_{RCH}	0	—	0	—	0	—	ns	12
Read command hold time from $\overline{\text{RAS}}$	t_{RCHR}	50	—	60	—	70	—	ns	
Read command hold time to $\overline{\text{RAS}}$	t_{RRH}	0	—	0	—	0	—	ns	12
Column address to $\overline{\text{RAS}}$ lead time	t_{RAL}	25	—	30	—	35	—	ns	
Column address to $\overline{\text{CAS}}$ lead time	t_{CAL}	15	—	18	—	23	—	ns	
$\overline{\text{CAS}}$ to output in low-Z	t_{CLZ}	0	—	0	—	0	—	ns	
Output data hold time	t_{OH}	3	—	3	—	3	—	ns	22
Output data hold time from $\overline{\text{OE}}$	t_{OHO}	3	—	3	—	3	—	ns	
Output buffer turn-off time	t_{OFF}	—	13	—	15	—	15	ns	13, 22
Output buffer turn-off to $\overline{\text{OE}}$	t_{OEZ}	—	13	—	15	—	15	ns	13
$\overline{\text{CAS}}$ to Din delay time	t_{CDD}	13	—	15	—	18	—	ns	5
Output data hold time from $\overline{\text{RAS}}$	t_{OHR}	3	—	3	—	3	—	ns	22
Output buffer turn-off to $\overline{\text{RAS}}$	t_{OFR}	—	13	—	15	—	15	ns	22
Output buffer turn-off to $\overline{\text{WE}}$	t_{WEZ}	—	13	—	15	—	15	ns	
$\overline{\text{WE}}$ to Din delay time	t_{WED}	13	—	15	—	18	—	ns	
$\overline{\text{RAS}}$ to Din delay time	t_{RDD}	13	—	15	—	18	—	ns	
$\overline{\text{RAS}}$ next $\overline{\text{CAS}}$ delay time	t_{RNCD}	50	—	60	—	70	—	ns	

HM5116405 Series, HM5117405 Series

Write Cycle

		HM5116405/HM5117405							
		-5		-6		-7			
Parameter	Symbol	Min	Max	Min	Max	Min	Max	Unit	Notes
Write command setup time	t_{WCS}	0	—	0	—	0	—	ns	14
Write command hold time	t_{WCH}	7	—	10	—	13	—	ns	
Write command pulse width	t_{WP}	7	—	10	—	10	—	ns	
Write command to \overline{RAS} lead time	t_{RWL}	7	—	10	—	13	—	ns	
Write command to \overline{CAS} lead time	t_{CWL}	7	—	10	—	13	—	ns	
Data-in setup time	t_{DS}	0	—	0	—	0	—	ns	15
Data-in hold time	t_{DH}	7	—	10	—	13	—	ns	15

Read-Modify-Write Cycle

		HM5116405/HM5117405							
		-5		-6		-7			
Parameter	Symbol	Min	Max	Min	Max	Min	Max	Unit	Notes
Read-modify-write cycle time	t_{RWC}	111	—	135	—	161	—	ns	
\overline{RAS} to \overline{WE} delay time	t_{RWD}	67	—	79	—	92	—	ns	14
\overline{CAS} to \overline{WE} delay time	t_{CWD}	30	—	34	—	40	—	ns	14
Column address to \overline{WE} delay time	t_{AWD}	42	—	49	—	57	—	ns	14
\overline{OE} hold time from \overline{WE}	t_{OEH}	13	—	15	—	18	—	ns	

Refresh Cycle

		HM5116405/HM5117405							
		-5		-6		-7			
Parameter	Symbol	Min	Max	Min	Max	Min	Max	Unit	Notes
\overline{CAS} setup time (CBR refresh cycle)	t_{CSR}	5	—	5	—	5	—	ns	
\overline{CAS} hold time (CBR refresh cycle)	t_{CHR}	7	—	10	—	10	—	ns	
\overline{WE} setup time (CBR refresh cycle)	t_{WRP}	0	—	0	—	0	—	ns	
\overline{WE} hold time (CBR refresh cycle)	t_{WRH}	7	—	10	—	10	—	ns	
\overline{RAS} precharge to \overline{CAS} hold time	t_{RPC}	5	—	5	—	5	—	ns	

HM5116405 Series, HM5117405 Series

EDO Page Mode Cycle

Parameter	Symbol	HM51W16405/HM51W17405						Unit	Notes
		-5		-6		-7			
		Min	Max	Min	Max	Min	Max		
EDO page mode cycle time	t_{HPC}	20	—	25	—	30	—	ns	21
EDO page mode \overline{RAS} pulse width	t_{RASP}	—	100000	—	100000	—	100000	ns	16
Access time from \overline{CAS} precharge	t_{CPA}	—	28	—	35	—	40	ns	9, 17, 20
\overline{RAS} hold time from \overline{CAS} precharge	t_{CPRH}	28	—	35	—	40	—	ns	
Output data hold time from \overline{CAS} low	t_{DOH}	3	—	3	—	3	—	ns	9, 17
\overline{CAS} hold time referred \overline{OE}	t_{COL}	7	—	10	—	13	—	ns	
\overline{CAS} to \overline{OE} setup time	t_{COP}	5	—	5	—	5	—	ns	
Read command hold time from \overline{CAS} precharge	t_{RCHC}	28	—	35	—	40	—	ns	

EDO Page Mode Read-Modify-Write Cycle

Parameter	Symbol	HM5116405/HM5117405						Unit	Notes
		-5		-6		-7			
		Min	Max	Min	Max	Min	Max		
EDO page mode read- modify-write cycle time	t_{HPRWC}	57	—	68	—	79	—	ns	
\overline{WE} delay time from \overline{CAS} precharge	t_{CPW}	45	—	54	—	62	—	ns	14

Test Mode Cycle *19

Parameter	Symbol	HM5116405/HM5117405						Unit	Notes
		-5		-6		-7			
		Min	Max	Min	Max	Min	Max		
Test mode \overline{WE} setup time	t_{WTS}	0	—	0	—	0	—	ns	
Test mode \overline{WE} hold time	t_{WTH}	7	—	10	—	10	—	ns	

Refresh (HM5116405 Series)

Parameter	Symbol	Max	Unit	Notes
Refresh period	t_{REF}	64	ms	4096 cycles
Refresh period (L-version)	t_{REF}	128	ms	4096 cycles

HM5116405 Series, HM5117405 Series

Refresh (HM5117405 Series)

Parameter	Symbol	Max	Unit	Notes
Refresh period	t_{REF}	32	ms	2048 cycles
Refresh period (L-version)	t_{REF}	128	ms	2048 cycles

- Notes:
- AC measurements assume $t_T = 2$ ns.
 - An initial pause of 200 μ s is required after power up followed by a minimum of eight initialization cycles (any combination of cycles containing \overline{RAS} -only refresh or \overline{CAS} -before- \overline{RAS} refresh). If the internal refresh counter is used, a minimum of eight \overline{CAS} -before- \overline{RAS} refresh cycles are required.
 - Operation with the t_{RCD} (max) limit insures that t_{RAC} (max) can be met, t_{RCD} (max) is specified as a reference point only; if t_{RCD} is greater than the specified t_{RCD} (max) limit, then access time is controlled exclusively by t_{CAC} .
 - Operation with the t_{RAD} (max) limit insures that t_{RAC} (max) can be met, t_{RAD} (max) is specified as a reference point only; if t_{RAD} is greater than the specified t_{RAD} (max) limit, then access time is controlled exclusively by t_{AA} .
 - Either t_{OED} or t_{CDD} must be satisfied.
 - Either t_{DZO} or t_{DZC} must be satisfied.
 - V_{IH} (min) and V_{IL} (max) are reference levels for measuring timing of input signals. Also, transition times are measured between V_{IH} (min) and V_{IL} (max).
 - Assumes that $t_{RCD} \leq t_{RCD}$ (max) and $t_{RAD} \leq t_{RAD}$ (max). If t_{RCD} or t_{RAD} is greater than the maximum recommended value shown in this table, t_{RAC} exceeds the value shown.
 - Measured with a load circuit equivalent to 1 TTL loads and 100 pF.
 - Assumes that $t_{RCD} \geq t_{RCD}$ (max) and $t_{RCD} + t_{CAC}$ (max) $\geq t_{RAD} + t_{AA}$ (max).
 - Assumes that $t_{RAD} \geq t_{RAD}$ (max) and $t_{RCD} + t_{CAC}$ (max) $\leq t_{RAD} + t_{AA}$ (max).
 - Either t_{RCH} or t_{RRH} must be satisfied for a read cycles.
 - t_{OFF} (max) and t_{OEZ} (max) define the time at which the outputs achieve the open circuit condition and are not referred to output voltage levels.
 - t_{WCS} , t_{RWD} , t_{CWD} , t_{AWD} and t_{CPW} are not restrictive operating parameters. They are included in the data sheet as electrical characteristics only; if $t_{WCS} \geq t_{WCS}$ (min), the cycle is an early write cycle and the data out pin will remain open circuit (high impedance) throughout the entire cycle; if $t_{RWD} \geq t_{RWD}$ (min), $t_{CWD} \geq t_{CWD}$ (min), and $t_{AWD} \geq t_{AWD}$ (min), or $t_{CWD} \geq t_{CWD}$ (min), $t_{AWD} \geq t_{AWD}$ (min) and $t_{CPW} \geq t_{CPW}$ (min), the cycle is a read-modify-write and the data output will contain data read from the selected cell; if neither of the above sets of conditions is satisfied, the condition of the data out (at access time) is indeterminate.
 - These parameters are referred to \overline{CAS} leading edge in early write cycles and to \overline{WE} leading edge in delayed write or read-modify-write cycles.
 - t_{RASP} defines \overline{RAS} pulse width in EDO page mode cycles.
 - Access time is determined by the longest among t_{AA} , t_{CAC} and t_{CPA} .
 - In delayed write or read-modify-write cycles, \overline{OE} must disable output buffer prior to applying data to device.
 - The 16M DRAM offers a 16-bit time saving parallel test mode. Address CA0 and CA1 for the 4M $\times 4$ are don't care during test mode. Test mode is set by performing a \overline{WE} -and- \overline{CAS} -before- \overline{RAS} (WCBR) cycle. In 16-bit parallel test mode, data is written into 4 bits in parallel at each I/O (I/O1 to I/O4) and read out from each I/O.
If 4 bits of each I/O are equal (all 1s or 0s), data output pin is a high state during test mode read cycle, then the device has passed. If they are not equal, data output pin is a low state, then the device has failed.
Refresh during test mode operation can be performed by normal read cycles or by WCBR refresh cycles.

HM5116405 Series, HM5117405 Series

To get out of test mode and enter a normal operation mode, perform either a regular $\overline{\text{CAS}}$ -before- $\overline{\text{RAS}}$ refresh cycle or RAS-only refresh cycle.

20. In a test mode read cycle, the value of t_{RAC} , t_{AA} , t_{CAC} and t_{CPA} is delayed by 2 ns to 5 ns for the specified value. These parameters should be specified in test mode cycles by adding the above value to the specified value in this data sheet.
21. t_{HPC} (min) can be achieved during a series of EDO page mode write cycles or EDO page mode read cycles. If both write and read operation are mixed in a EDO page mode $\overline{\text{RAS}}$ cycle (EDO page mode mix cycle (1), (2)), minimum value of $\overline{\text{CAS}}$ cycle ($t_{\text{CAS}} + t_{\text{CP}} + 2 t_{\text{T}}$) becomes greater than the specified t_{HPC} (min) value. The value of $\overline{\text{CAS}}$ cycle time of mixed EDO page mode is shown in EDO page mode mix cycle (1) and (2).
Data output turns off and becomes high impedance from later rising edge of $\overline{\text{RAS}}$ and $\overline{\text{CAS}}$.
Hold time and turn off time are specified by the timing specifications of later rising edge of $\overline{\text{RAS}}$ and $\overline{\text{CAS}}$ between t_{OHR} and t_{OH} , and between t_{OFR} and t_{OFF} .
22. Data output turns off and becomes high impedance from later rising edge of $\overline{\text{RAS}}$ and $\overline{\text{CAS}}$.
Hold time and turn off time are specified by the timing specifications of later rising edge of $\overline{\text{RAS}}$ and $\overline{\text{CAS}}$ between t_{OHR} and t_{OH} and between t_{OFR} and t_{OFF} .
23. XXX: H or L (H: $V_{\text{IH}} (\text{min}) \leq V_{\text{IN}} \leq V_{\text{IH}} (\text{max})$, L: $V_{\text{IL}} (\text{min}) \leq V_{\text{IN}} \leq V_{\text{IL}} (\text{max})$)
/////: Invalid Dout
When the address, clock and input pins are not described on timing waveforms, their pins must be applied V_{IH} or V_{IL} .

HM5116405 Series, HM5117405 Series

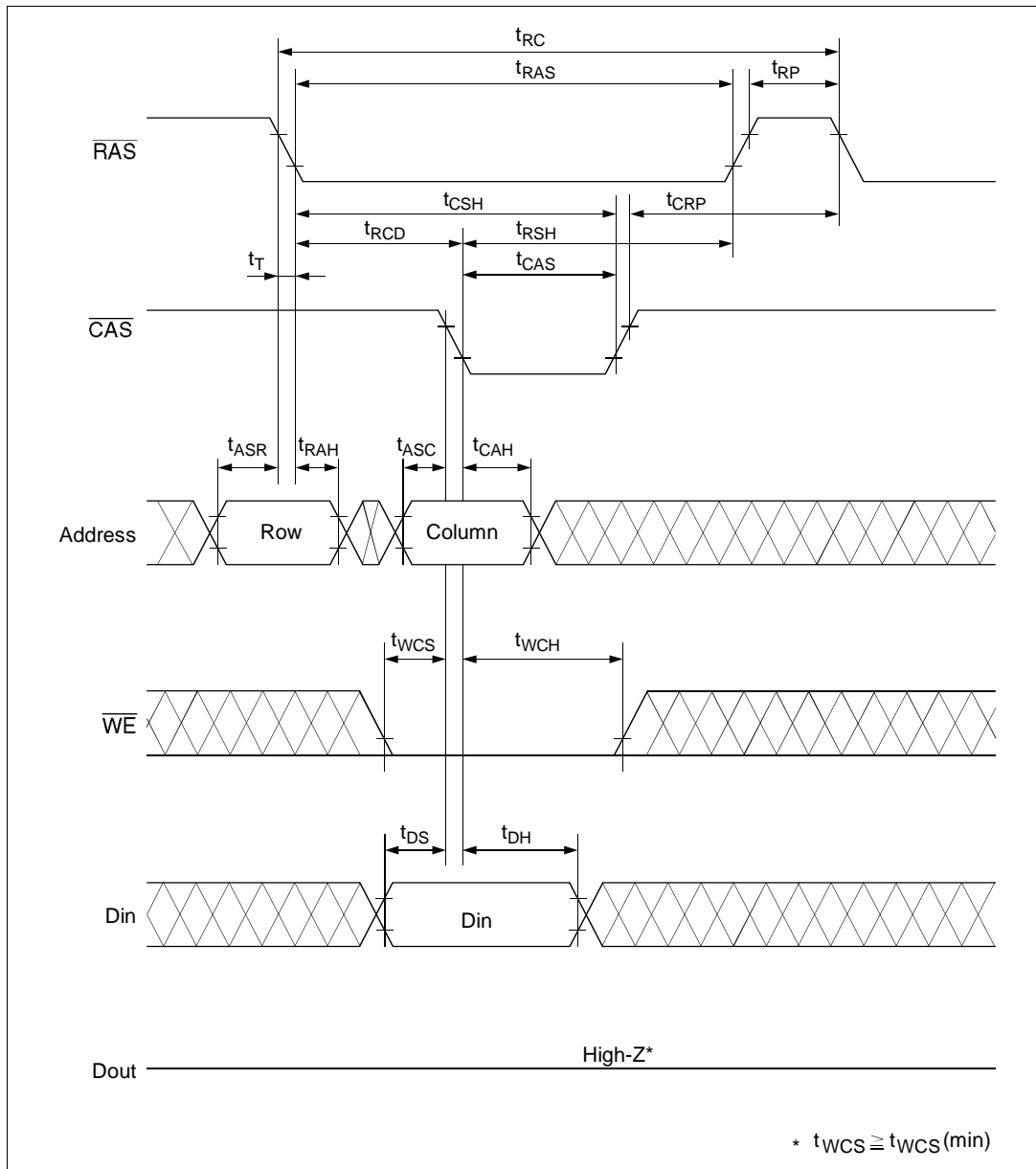

HM5116405 Series, HM5117405 Series

Read-Modify-Write Cycle*18

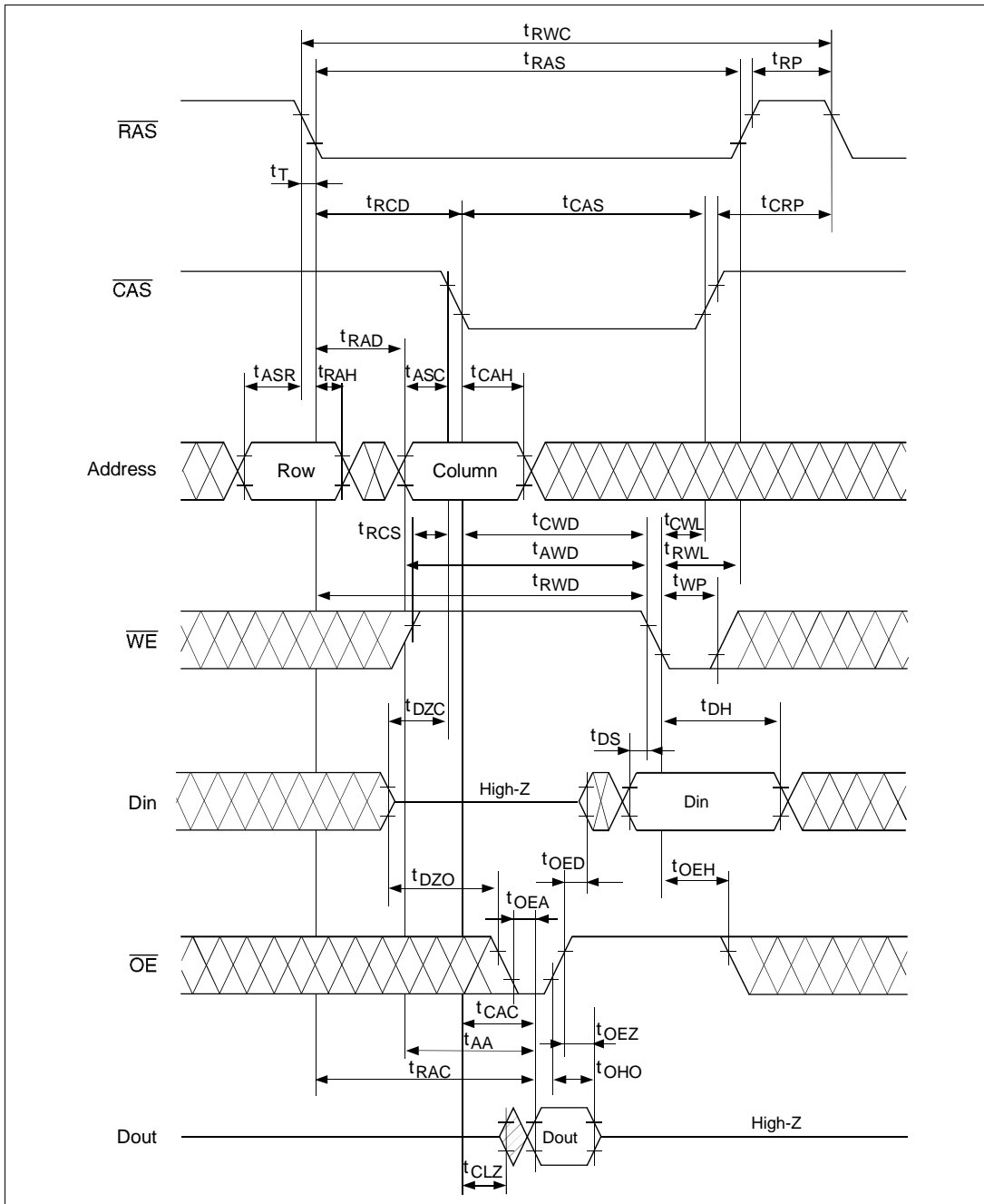

RAS-Only Refresh Cycle

HM5116405 Series, HM5117405 Series

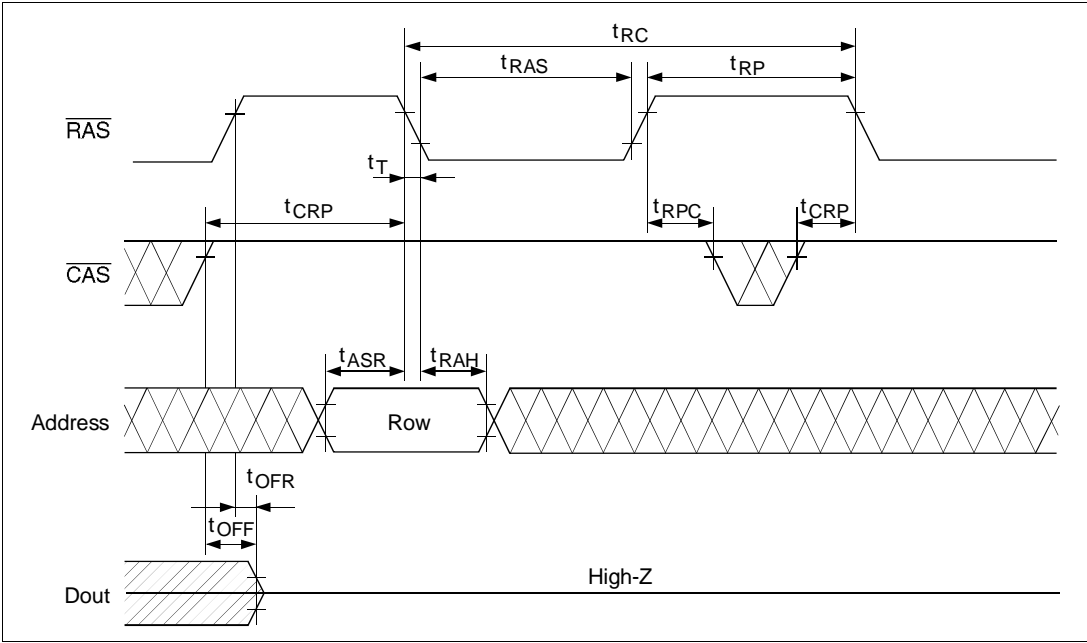

HM5116405 Series, HM5117405 Series

$\overline{\text{CAS}}$ -Before- $\overline{\text{RAS}}$ Refresh Cycle

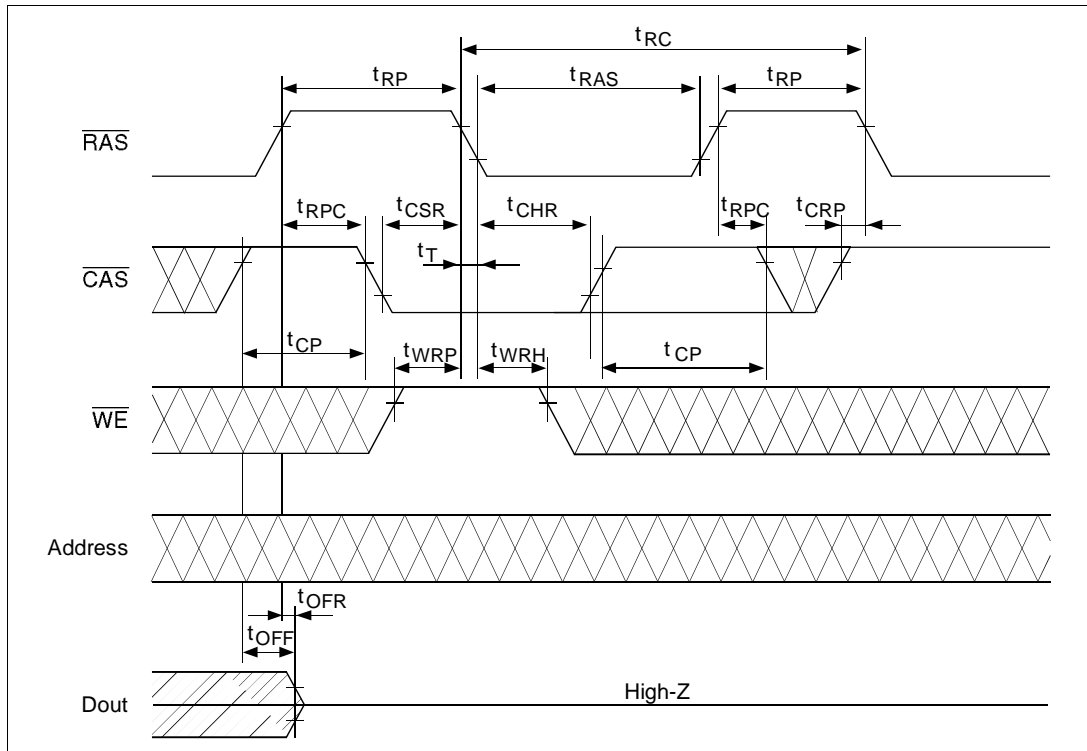

HM5116405 Series, HM5117405 Series

Hidden Refresh Cycle

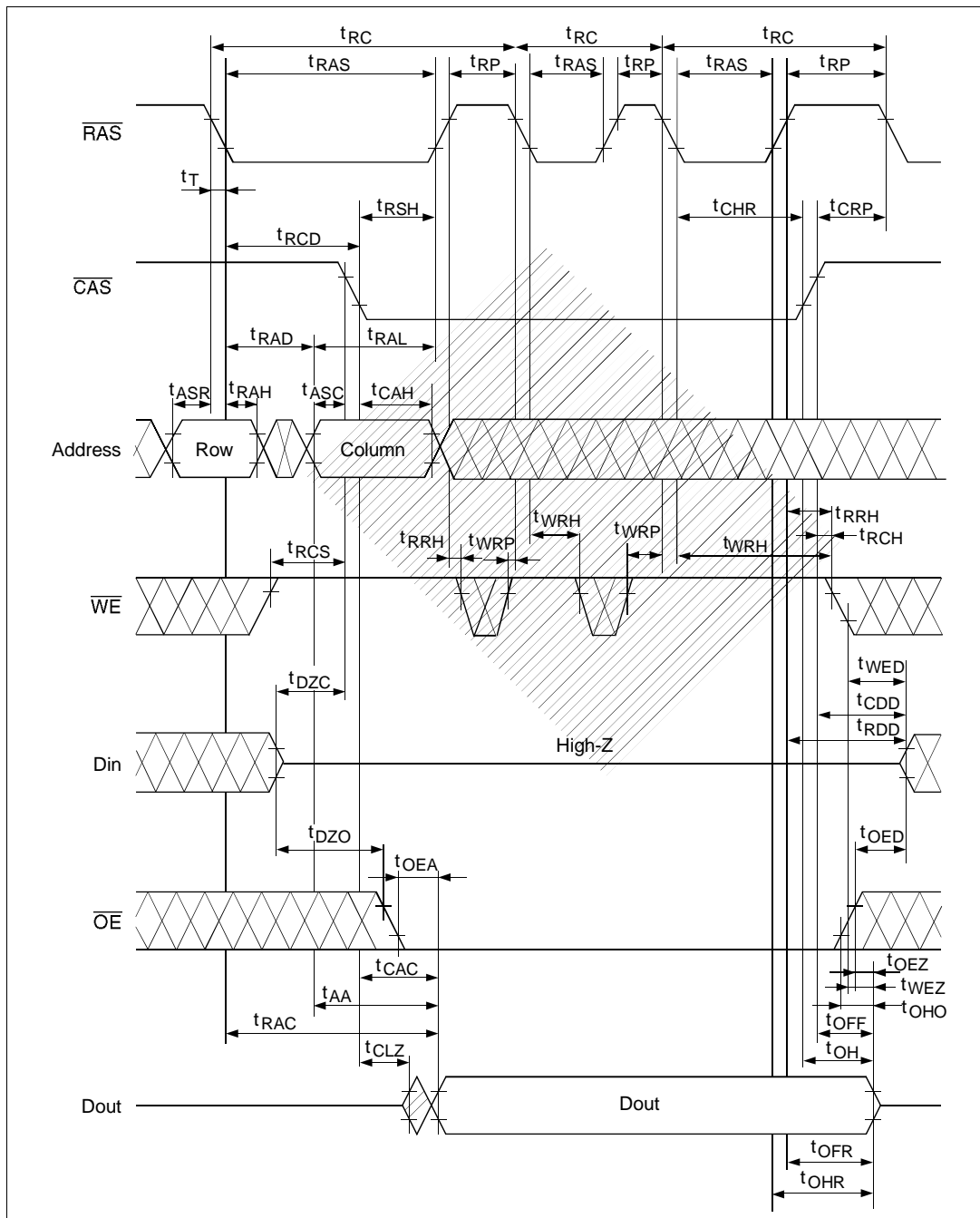

HM5116405 Series, HM5117405 Series

EDO Page Mode Read Cycle

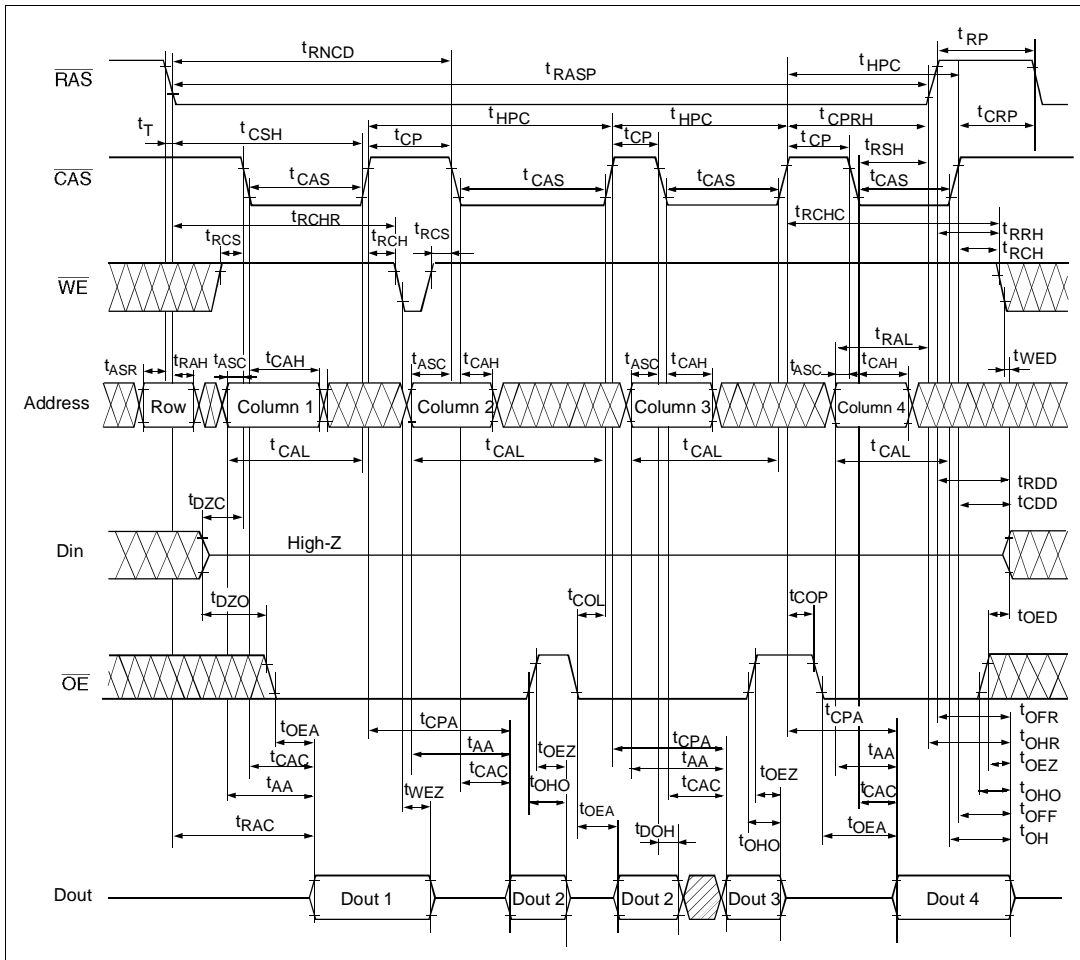

HM5116405 Series, HM5117405 Series

EDO Page Mode Early Write Cycle

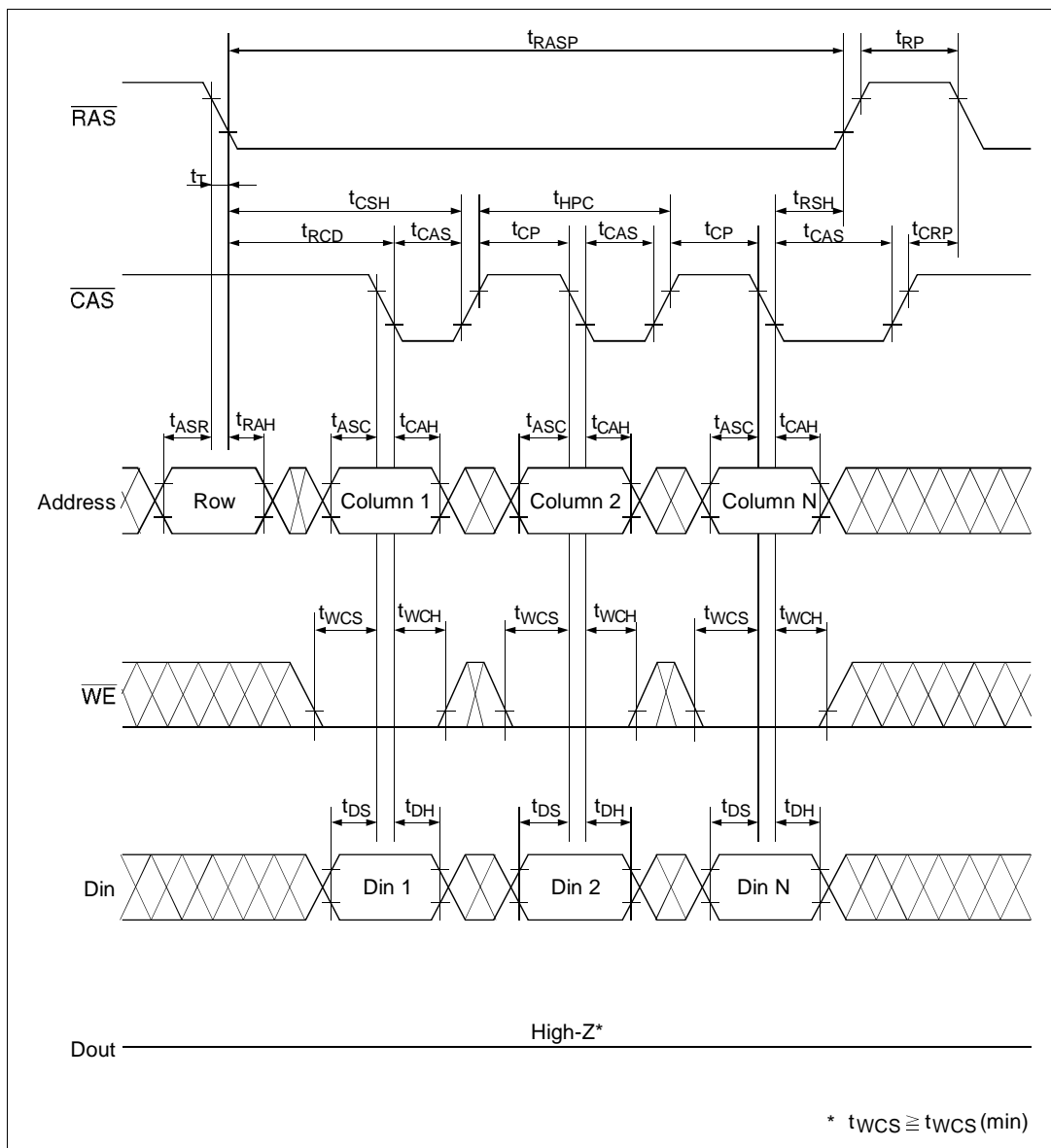

HM5116405 Series, HM5117405 Series

EDO Page Mode Delayed Write Cycle*18

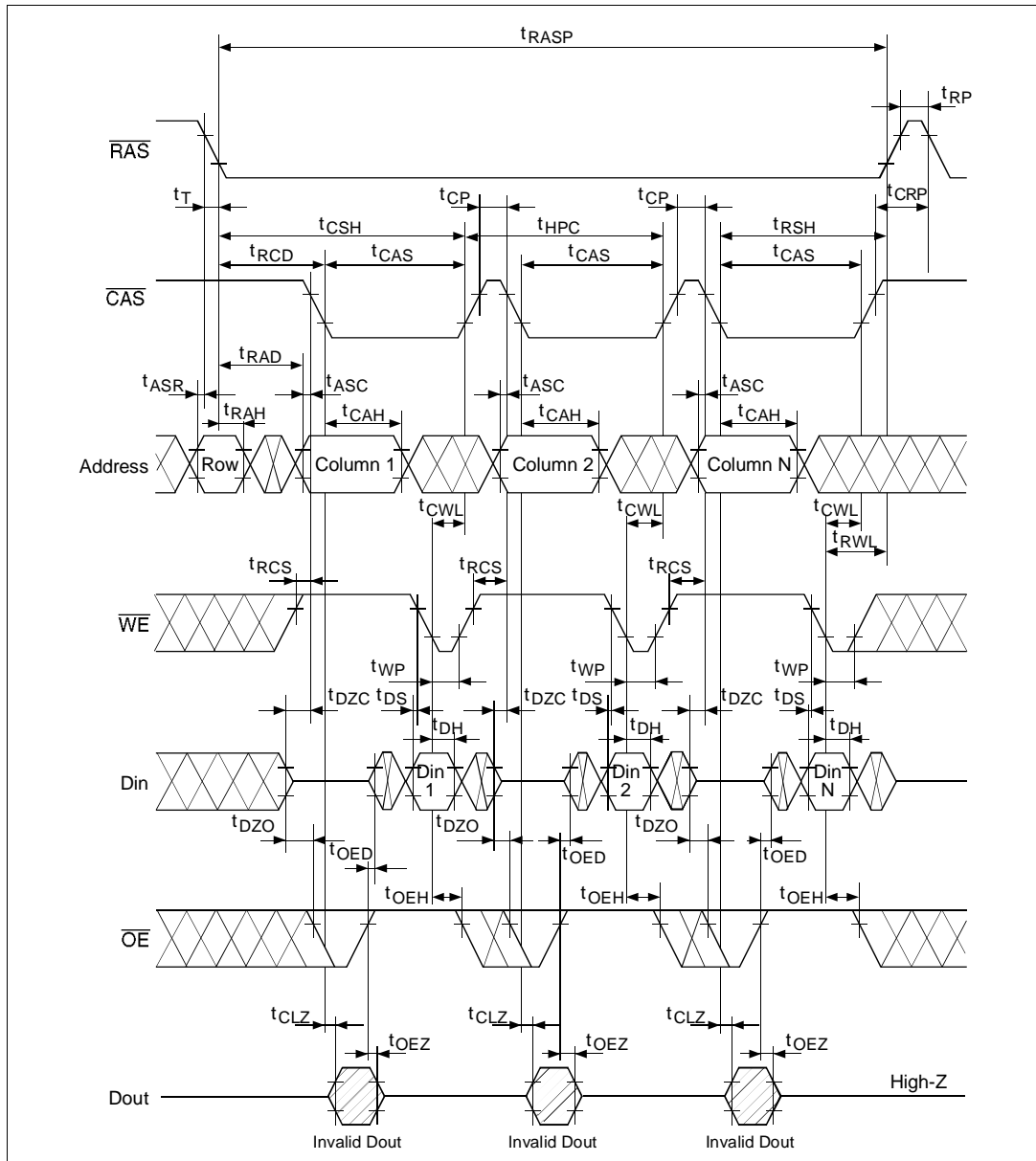

HM5116405 Series, HM5117405 Series

EDO Page Mode Read-Modify-Write Cycle*18

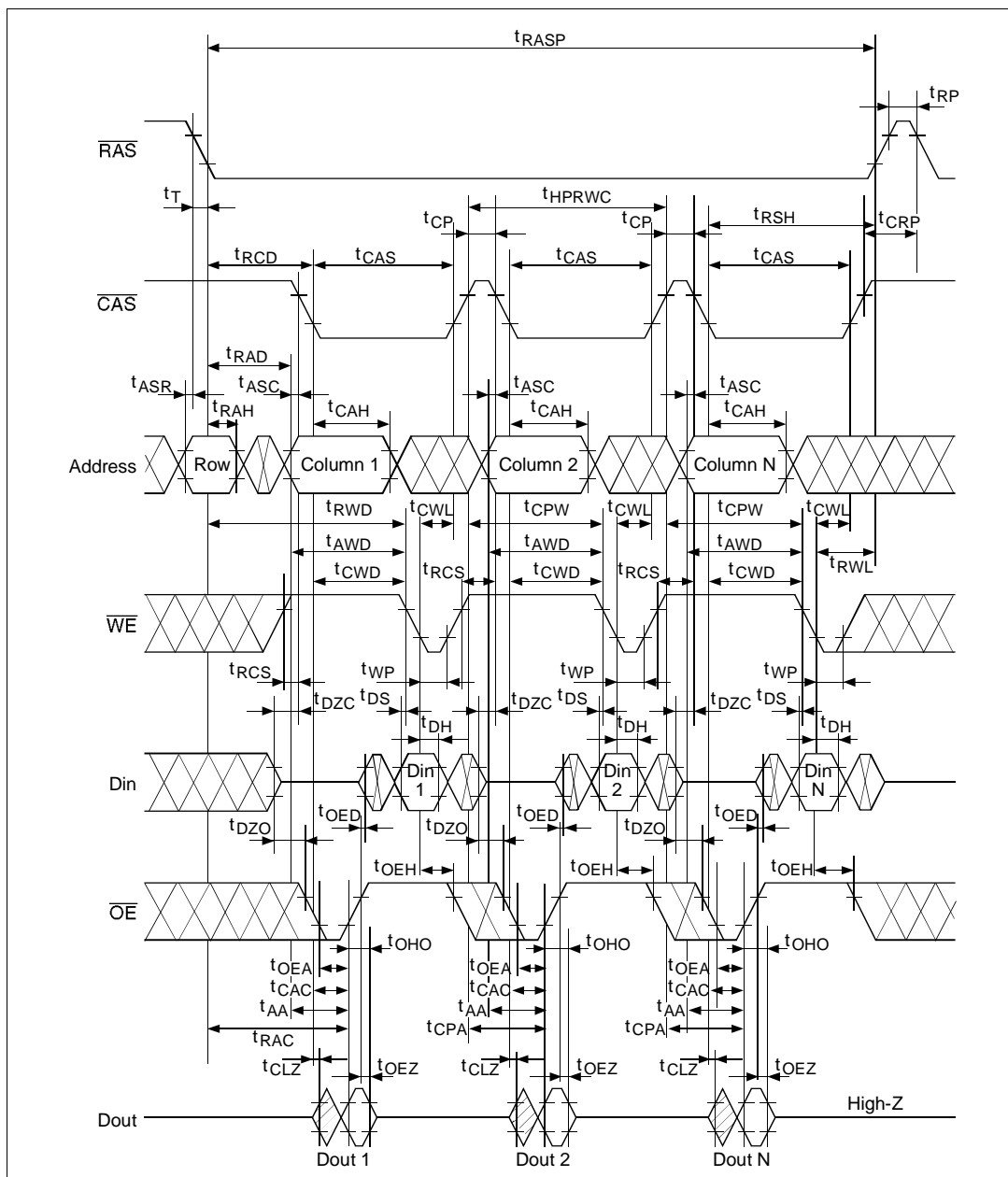

HM5116405 Series, HM5117405 Series

EDO Page Mode Mix Cycle (1)

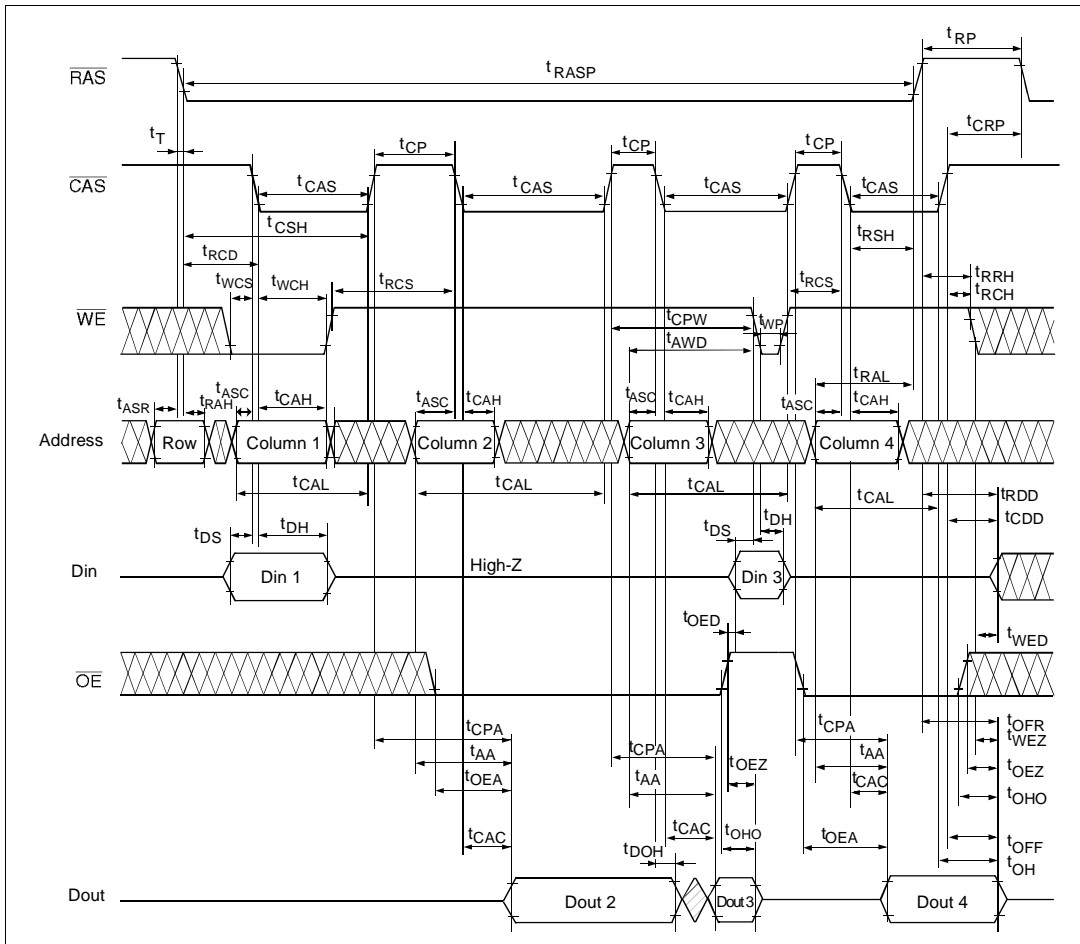

HM5116405 Series, HM5117405 Series

Test Mode Cycle *19

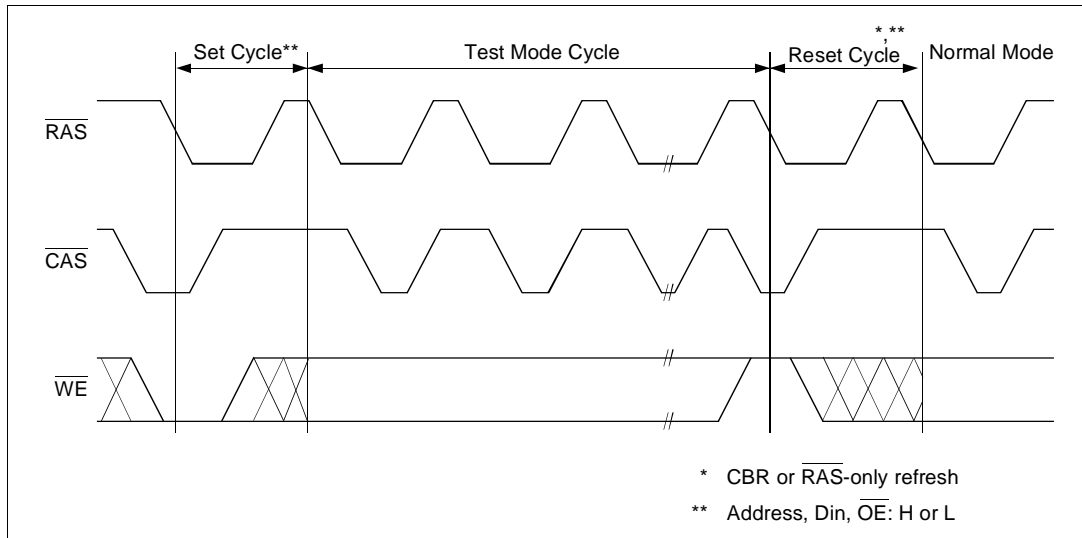

HM5116405 Series, HM5117405 Series

Test Mode Set Cycle

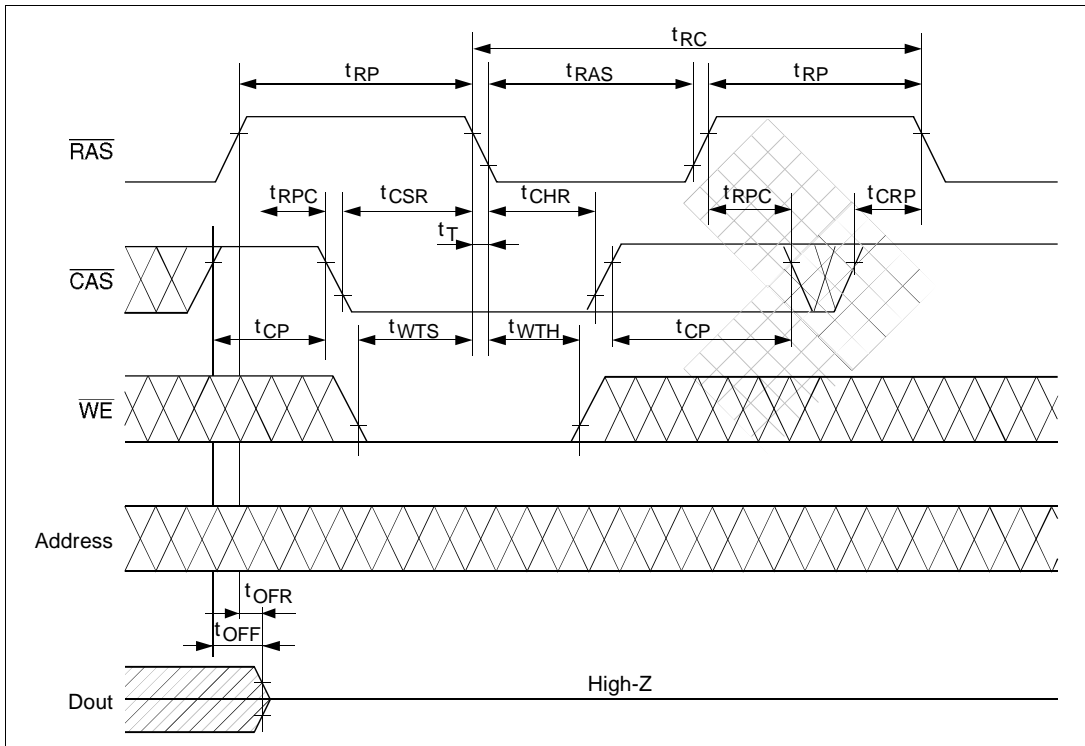

HM5116405 Series, HM5117405 Series

Package Dimensions

HM5116405S/LS Series

HM5117405S/LS Series (CP-26/24DB)

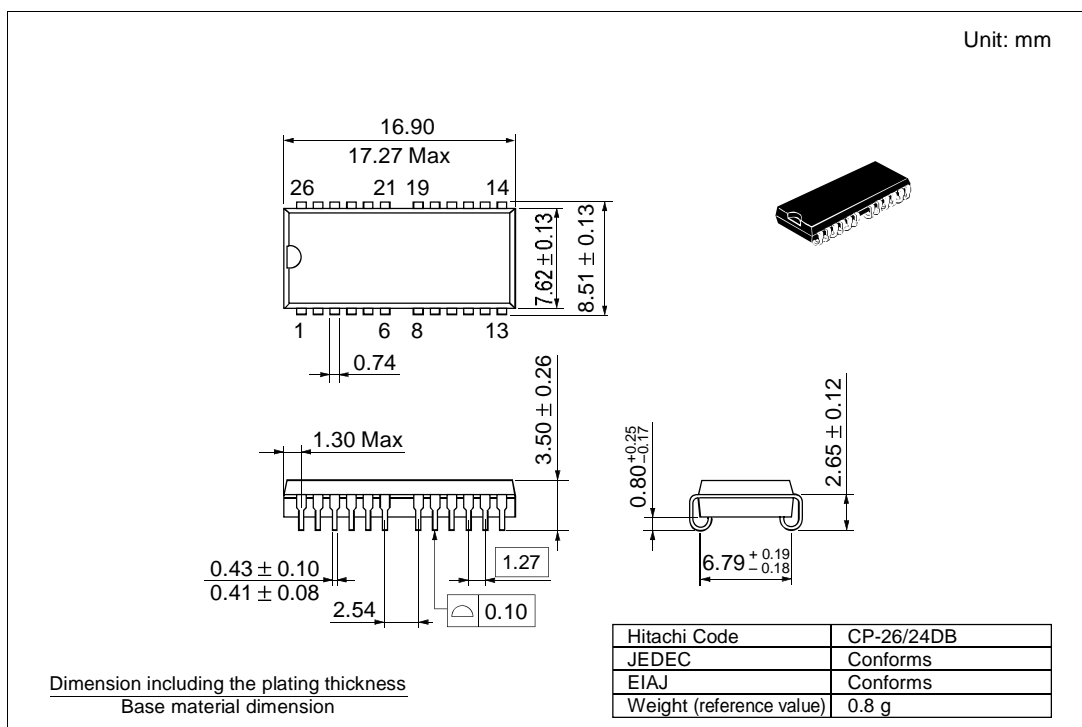

HM5116405 Series, HM5117405 Series

HM5116405TS/LTS Series
 HM5117405TS/LTS Series (TTP-26/24DA)

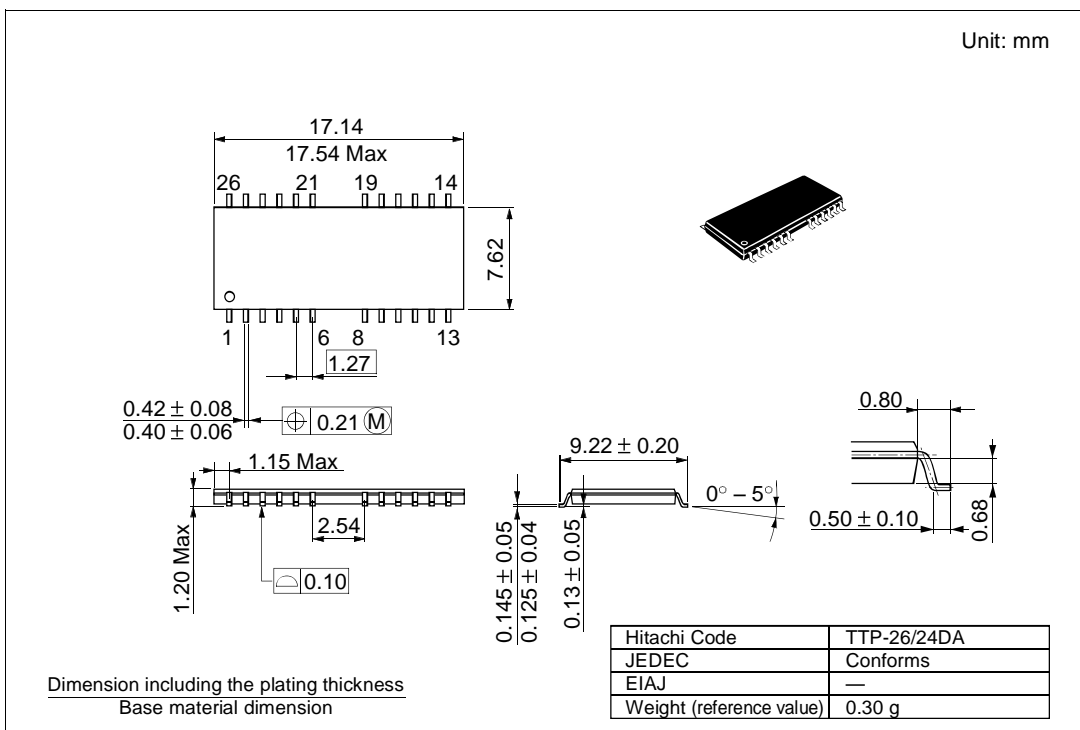

HM5116405 Series, HM5117405 Series

When using this document, keep the following in mind:

1. This document may, wholly or partially, be subject to change without notice.
2. All rights are reserved: No one is permitted to reproduce or duplicate, in any form, the whole or part of this document without Hitachi's permission.
3. Hitachi will not be held responsible for any damage to the user that may result from accidents or any other reasons during operation of the user's unit according to this document.
4. Circuitry and other examples described herein are meant merely to indicate the characteristics and performance of Hitachi's semiconductor products. Hitachi assumes no responsibility for any intellectual property claims or other problems that may result from applications based on the examples described herein.
5. No license is granted by implication or otherwise under any patents or other rights of any third party or Hitachi, Ltd.
6. **MEDICAL APPLICATIONS:** Hitachi's products are not authorized for use in **MEDICAL APPLICATIONS** without the written consent of the appropriate officer of Hitachi's sales company. Such use includes, but is not limited to, use in life support systems. Buyers of Hitachi's products are requested to notify the relevant Hitachi sales offices when planning to use the products in **MEDICAL APPLICATIONS**.

HITACHI

Hitachi, Ltd.

Semiconductor & IC Div.
Nippon Bldg., 2-6-2, Ohte-machi, Chiyoda-ku, Tokyo 100, Japan
Tel: Tokyo (03) 3270-2111
Fax: (03) 3270-5109

For further information write to:

Hitachi Semiconductor
(America) Inc.
2000 Sierra Point Parkway
Brisbane, CA. 94005-1897
U S A
Tel: 800-285-1601
Fax: 303-297-0447

Hitachi Europe GmbH
Continental Europe
Dornacher Straße 3
D-85622 Feldkirchen
München
Tel: 089-9 91 80-0
Fax: 089-9 29 30-00

Hitachi Europe Ltd.
Electronic Components Div.
Northern Europe Headquarters
Whitebrook Park
Lower Cookham Road
Maidenhead
Berkshire SL6 8YA
United Kingdom
Tel: 01628-585000
Fax: 01628-585160

Hitachi Asia Pte. Ltd.
16 Collyer Quay #20-00
Hitachi Tower
Singapore 049318
Tel: 535-2100
Fax: 535-1533

Hitachi Asia (Hong Kong) Ltd.
Unit 706, North Tower,
World Finance Centre,
Harbour City, Canton Road
Tsim Sha Tsui, Kowloon
Hong Kong
Tel: 27359218
Fax: 27306071

Copyright © Hitachi, Ltd., 1997. All rights reserved. Printed in Japan.

HM5116405 Series, HM5117405 Series

Revision Record

Rev.	Date	Contents of Modification	Drawn by	Approved by
1.0	Oct. 14, 1996	Initial issue	Y. Kasama	M. Mishima
2.0	Nov. 8, 1996	Addition of HM5116405-5 Series Addition of HM5117405-5 Series Power dissipation (active) 550/495 mW(max) to 495/440/385 mW (max) (HM5116405 Series) 605/550 mW(max) to 550/495/440 mW (max) (HM5117405 Series) DC Characteristics (HM5116405 Series) I _{CC7} max: 110/100 mA to 80/70/65 mA DC Characteristics (HM5117405 Series) I _{CC1} max: 110/100 mA to 100/90/80 mA I _{CC3} max: 110/100 mA to 100/90/80 mA I _{CC6} max: 110/100 mA to 100/90/80 mA I _{CC7} max: 110/100 mA to 90/80/75 mA AC Characteristics t _{RCD} min: 20/20 ns to 11/14/14 ns t _{RAD} min: 15/15 ns to 9/12/12 ns t _{RSH} min: 15/18 ns to 10/13/13 ns t _{RRH} min: 0/0 ns to 5/5/5 ns t _{RWC} min: 149/175 ns to 111/135/161 ns t _{RWD} min: 82/95 ns to 67/79/92 ns t _{CWD} min: 37/43 ns to 30/34/40 ns t _{AWD} min: 52/60 ns to 42/49/57 ns t _{RPC} min: 0/0 ns to 5/5/5 ns t _{HPRWC} min: 79/90 ns to 57/68/79 ns Timing Waveforms Addition of t _{RNCD} timing to EDO page mode mix cycle (2)	Y. Kasama	Y. Matsuno
3.0	Feb. 27, 1997	AC Characteristics t _{RRH} min: 5/5/5 ns to 0/0/0 ns	Y. Kasama	Y. Matsuno
4.0	Nov. 1997	Change of Subtitle		