

# HOA2001

## Transmissive Optoschmitt Sensor

### FEATURES

- Direct TTL interface
- Buffer logic
- 0.060 in.(1.52 mm) dia. detector aperture
- 0.120 in.(3.05 mm) slot width
- 0.050 in.(1.27) offset pin circle detector eads

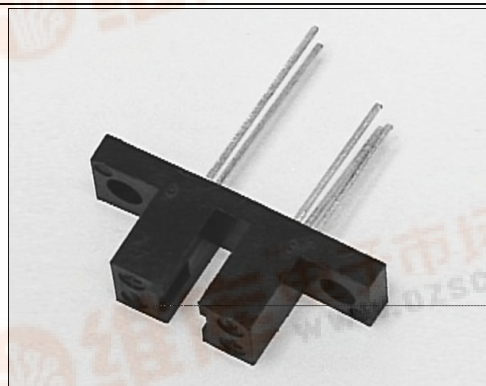

INFRA-45.TIF

### DESCRIPTION

The HOA2001 consists of an infrared emitting diode facing an Optoschmitt detector encased in a black thermoplastic housing. The photodetector consists of a photodiode, amplifier, voltage regulator, Schmitt trigger and an NPN output transistor with 10 kΩ (nominal) pull-up resistor. The buffer logic provides a high output when the optical path is clear, and a low output when the path is interrupted. The HOA2001 employs plastic molded components. For additional component information see SEP8506 and SDP8600.

Housing material is polyester. Housings are soluble in chlorinated hydrocarbons and ketones. Recommended cleaning agents are methanol and isopropanol.

### OUTLINE DIMENSIONS in inches (mm)

Tolerance 3 plc decimals ±0.010(0.25)  
2 plc decimals ±0.020(0.51)

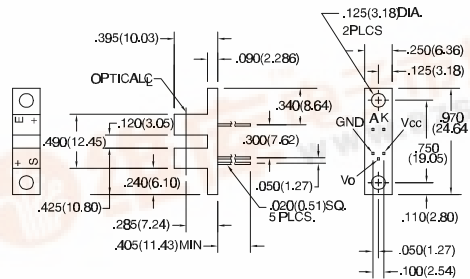

DIM\_062.ds4



# HOA2001

## Transmissive Optoschmitt Sensor

### ELECTRICAL CHARACTERISTICS (25°C unless otherwise noted)

PARAMETER	SYMBOL	MIN	TYP	MAX	UNITS	TEST CONDITIONS
<b>IR EMITTER</b>						
Forward Voltage	$V_F$			1.6	V	$I_F=20\text{ mA}$
Reverse Leakage Current	$I_R$			10	$\mu\text{A}$	$V_R=3\text{ V}$
<b>DETECTOR</b>						
Operating Supply Voltage	$V_{CC}$	4.5		10	V	
Low Level Supply Current	$I_{CC(L)}$	4.0		12	mA	$V_{CC}=5\text{ V}$
Low Level Supply Current		5.0		15		$V_{CC}=12\text{ V}$
High Level Supply Current	$I_{CC(H)}$	2.0		10	mA	$V_{CC}=5\text{ V}$
High Level Supply Current		3.0		12		$V_{CC}=12\text{ V}$
Low Level Output Voltage	$V_{OL}$			0.4	V	$I_{OL}=12.8\text{ mA}, I_F=0\text{ mA}$
High Level Output Voltage	$V_{OH}$	2.4			V	$I_{OH}=0, I_F=10\text{ mA}$
Hysteresis <sup>(2)</sup>	HYST		10		%	
Propagation Delay, Low-High	$t_{PLH}$		5		$\mu\text{s}$	$V_{CC}=5\text{ V}, I_F=10\text{ mA}$
Propagation Delay, High-Low	$t_{PHL}$		5		$\mu\text{s}$	$V_{CC}=5\text{ V}, I_F=10\text{ mA}$
Rise Time	$t_r$		60		ns	$R_L=390\ \Omega, C_L=50\text{ pF}$
Fall Time	$t_f$		15		ns	$R_L=390\ \Omega, C_L=50\text{ pF}$
<b>COUPLED CHARACTERISTICS</b>						
IRED Trigger Current	$I_{FT}$			10	mA	$V_{CC}=5\text{ V}$
HOA2001-001						

#### Notes

- It is recommended that a bypass capacitor, 0.1  $\mu\text{F}$  typical, be added between  $V_{CC}$  and GND near the device in order to stabilize power supply line.
- Hysteresis is defined as the difference between the operating and release threshold intensities, expressed as a percentage of the operate threshold intensity.

### ABSOLUTE MAXIMUM RATINGS

(25°C Free-Air Temperature unless otherwise noted)

Operating Temperature Range	-40°C to 70°C
Storage Temperature Range	-40°C to 85°C
Soldering Temperature (5 sec)	240°C
<b>IR EMITTER</b>	
Power Dissipation	100 mW <sup>(1)</sup>
Reverse Voltage	3 V
Continuous Forward Current	50 mA
<b>DETECTOR</b>	
Supply Voltage	12 V <sup>(2)</sup>
Output Sink Current	18 mA
Duration of Output	
Short to $V_{CC}$ or Ground	1.0 sec.

### SCHEMATIC

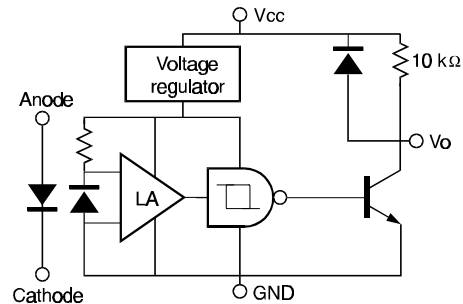

Honeywell reserves the right to make changes in order to improve design and supply the best products possible.

# Honeywell

# HOA2001

## Transmissive Optoschmitt Sensor

SWITCHING WAVEFORM

cir\_013.cdr

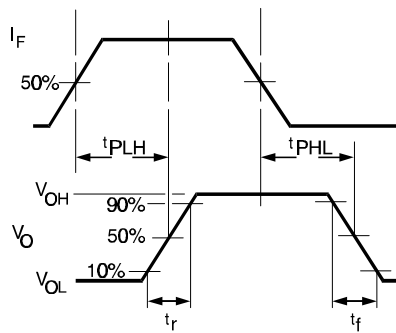
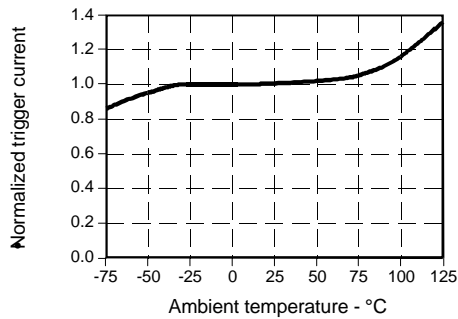

Fig. 2 IRED Trigger Current vs Temperature

gra\_098.ds4



All Performance Curves Show Typical Values

Fig. 1 IRED Forward Bias Characteristics

gra\_073.ds4

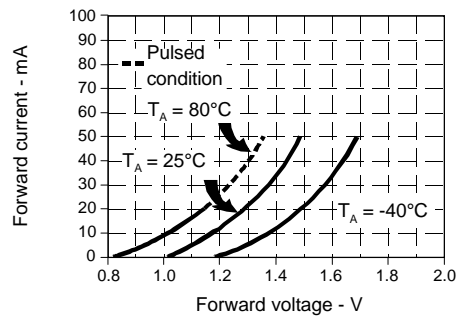

# HOA2001

Transmissive Optoschmitt Sensor

---

Honeywell reserves the right to make changes in order to improve design and supply the best products possible.

**Honeywell**

363