

HPWG-N500 HPWG-N506  
HPWG-N501 HPWG-N507  
HPWG-N502 HPWG-N508  
HPWG-N503 HPWG-N550  
HPWG-N504 HPWG-N551  
HPWG-N505 HPWG-N552

# SnapLED High Mount Stop Light Array

## Technical Data DS29

Using Lumiled's patented solderless clinch technology and SnapLED emitters, this six-LED linear assembly is an integrated LED stop-lamp solution complete with control circuitry.

In addition to three types of power connector, the HMSL product line offers vehicle designers a choice of three flux output levels for use on exterior mounts or for implementation behind the rear glass. Furthermore, SnapLED offers two radiation pattern options for use where greater luminous intensity is required. Where enhanced reliability is needed, high-voltage protection circuitry is provided. SnapLED HMSL features a compact and rugged design and provides a cost effective source for vehicle high-mount-stop lamps.

### Benefits

- Cost effective LED Solution for HMSL Applications
- Life of Vehicle Light Source
- Standard Design for Multiple Vehicle Applications
- Rugged and Compact

### Features

- Drive Circuitry and Connector Included
- Choice of connector type
- Light Source Sufficient for SAE/ECE/JIS HMSL Requirements



## Selection Guide (all lamps are TS AllnGaP Red-Orange and voltage is 12.8 volts)

PART NUMBER	DESCRIPTION	TOTAL FLUX $\Phi_v$ (lm) <sup>(1), (2)</sup>		POWER INPUT (W)	
		MIN.	MAX.	MIN.	MAX.
HPWG-N500	HMSL WITH PIN CONNECTOR	19.0	30.0	1.6	1.9
HPWG-N501	HMSL WITH PIN CONNECTOR	28.0	45.0	3.1	3.5
HPWG-N502	HMSL WITH PIN CONNECTOR	36.0	58.0	3.1	3.5
HPWG-N503	HMSL WITH VARISTOR & HOLE CONNECTOR	19.0	30.0	1.6	1.9
HPWG-N504	HMSL WITH VARISTOR & HOLE CONNECTOR	28.0	45.0	3.1	3.5
HPWG-N505	HMSL WITH VARISTOR & HOLE CONNECTOR	36.0	58.0	3.1	3.5
HPWG-N506	HMSL WITH WIRE CONNECTOR	19.0	30.0	1.6	1.9
HPWG-N507	HMSL WITH WIRE CONNECTOR	28.0	45.0	3.1	3.5
HPWG-N508	HMSL WITH WIRE CONNECTOR	36.0	58.0	3.1	3.5
HPWG-N550	HMSL WITH NARROW ANGLE LIGHT BEAM	19.0	30.0	1.6	1.9
HPWG-N551	HMSL WITH NARROW ANGLE LIGHT BEAM	28.0	45.0	3.1	3.5
HPWG-N552	HMSL WITH NARROW ANGLE LIGHT BEAM	36.0	58.0	3.1	3.5

### Notes:

1. Total integrated flux of the array at  $V_{in} = 12.8\text{ V}$ ,  $R_{th\text{ junction-ambient}} = 12.9^\circ\text{C/W}$ , which assumes that the array is attached to a thermally absorbing substrate. To determine junction temperature, multiply  $R_{th}$  by power consumption and add to ambient temperature.

2.  $\Phi_v$  is the total usable flux measured after the lamp has stabilized

## Circuit Schematic

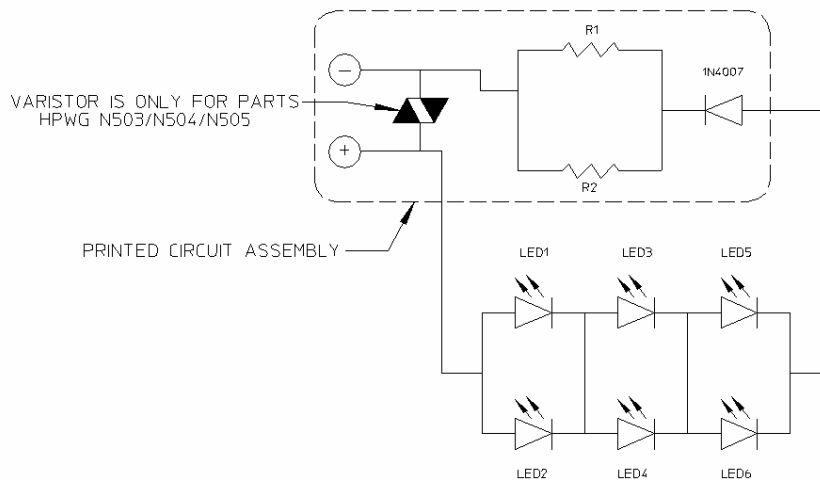

# Outline Drawing

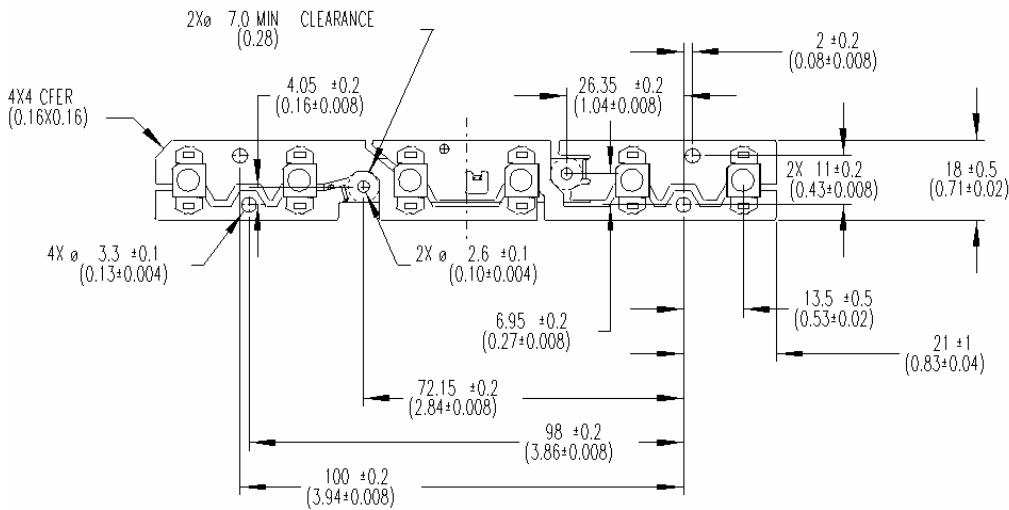
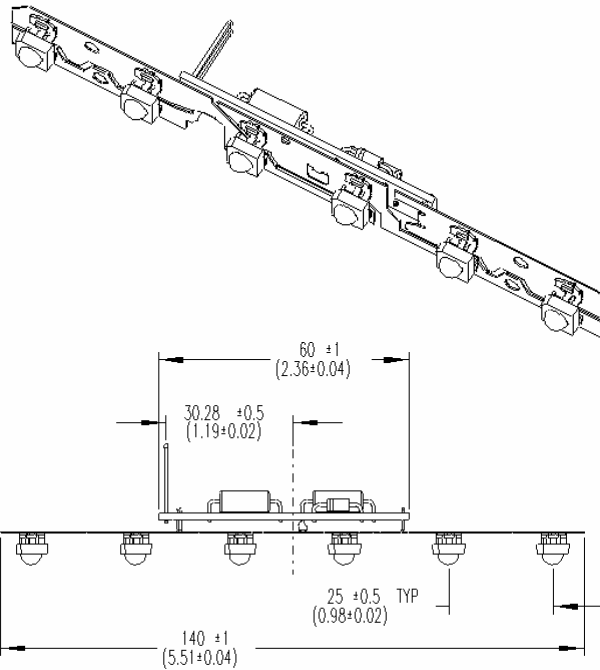

## Side View

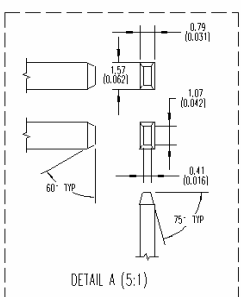

- NOTES:
1. SEE HPWS-TH00 OR HPWT-TH00 DATASHEET
  2. DIMENSIONS ARE IN MILLIMETERS (INCHES).
  3. DIMENSIONS WITHOUT TOLERANCES ARE NOMINAL.

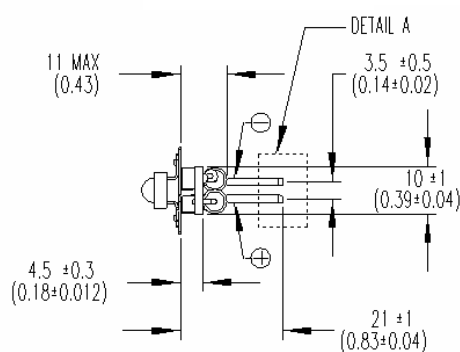

## Notes:

1. See HPWS-TH00 or HPWT-TH00 datasheet for emitter specifications.
2. Dimensions are in millimeters (inches).
3. Dimensions without tolerances are nominal.

## Absolute Maximum Ratings at $T_A = 25^\circ\text{C}$

PARAMETER	HPWG-N5xx	UNITS
DC INPUT OPERATING VOLTAGE <sup>(1)</sup>	16	V
POWER DISSIPATION	7.0	W
REVERSE VOLTAGE ( $I_R = 200 \mu\text{A}$ )	500	V
OPERATING TEMPERATURE RANGE(1 2.8V-1 3.5V) <sup>(2)</sup>	-40 TO +85	$^\circ\text{C}$
STORAGE TEMPERATURE RANGE	-55 TO +100	$^\circ\text{C}$
LED JUNCTION TEMPERATURE	125	$^\circ\text{C}$
HIGH TEMPERATURE CHAMBER	125 (2 HRS.)	$^\circ\text{C}$

### Notes:

- 16V operation is allowed at  $T_{\text{ambient}}=25^\circ\text{C}$  only.
- Temperature range for sustained operation based on  $R_{\text{th-junction-ambient}}=12.9^\circ\text{C/W}$ .

## Optical and Electrical Characteristics

DEVICE TYPE	OPERATIONAL FORWARD VOLTAGE $V_F$ (VOLTS)		COLOR DOMINANT WAVELENGTH $\lambda_d$ (nm) <sup>(1,2)</sup>	
	MIN.	MAX.	MIN.	MAX.
HPWG-N50x	9	16	611	634

### Notes:

- The dominant wavelength is derived from the CIE Chromaticity Diagram and represents the perceived color of the device.
- The dominant wavelength does not vary between emitters by more than 8nm within the same assembly.

## Company Information

---

Lumileds is a world-class supplier of Light Emitting Diodes (LEDs) producing billions of LEDs annually. Lumileds is a fully integrated supplier, producing core LED material in all three base colors (Red, Green, Blue) and White. Lumileds has R&D development centers in San Jose, California and Best, The Netherlands. Production capabilities in San Jose, California and Malaysia.

Lumileds is pioneering the high-flux LED technology and bridging the gap between solid-state LED technology and the lighting world. Lumileds is absolutely dedicated to bringing the best and brightest LED technology to enable new applications and markets in the Lighting world.



Lumileds may make process or materials changes affecting the performance or other characteristics of our products. These products supplied after such changes will continue to meet published specifications, but may not be identical to products supplied as samples or under prior orders.

### LUMILEDS

[www.luxeon.com](http://www.luxeon.com)  
[www.lumileds.com](http://www.lumileds.com)

For technical assistance or the location of your nearest Lumileds sales office, call:

Worldwide:  
+1 408-435-6044  
US Toll free: 877-298-9455  
Europe: +31 499 339 439  
Fax: 408-435-6855  
Email us at [info@lumileds.com](mailto:info@lumileds.com)

Lumileds Lighting, LLC  
370 West Trimble Road  
San Jose, CA 95131