



# HT1632

## 32×8 & 24×16 LED Driver

### Features

- Operating voltage: 2.4V~5.5V
- Multiple LED display – 32 out bits/8 commons and 24 out bits/16 commons
- Integrated display RAM – select 32 out bits & 8 commons for 64×4 display RAM, or select 24 outbits & 16 commons for 96×4 display RAM
- 16-level PWM brightness control
- Integrated 256kHz RC oscillator
- Serial MCU interface –  $\overline{CS}$ ,  $\overline{RD}$ ,  $\overline{WR}$ , DATA
- Data mode & command mode instruction
- Cascading function for extended applications (up to 5 HT1632s possible)
- Selectable NMOS open drain output driver and PMOS open drain output driver for commons
- 52-pin QFP package

### Applications

- Industrial control indicator
- Digital clock, thermometer, counter, voltmeter
- Instrumentation readouts
- Other consumer application
- LED Displays

### General Description

The HT1632 is a memory mapping LED display controller/driver, which can select a number of out bits and commons. These are 32 out bits & 8 commons and 24 out bits & 16 commons. The device supports 16-gradation LEDs for each out line using PWM control with software instructions. A serial interface is conveniently provided for the

command mode and data mode. Only three or four lines are required for the interface between the host controller and the HT1632. The display can be extended by cascading the HT1632 for wider applications.

### Block Diagram

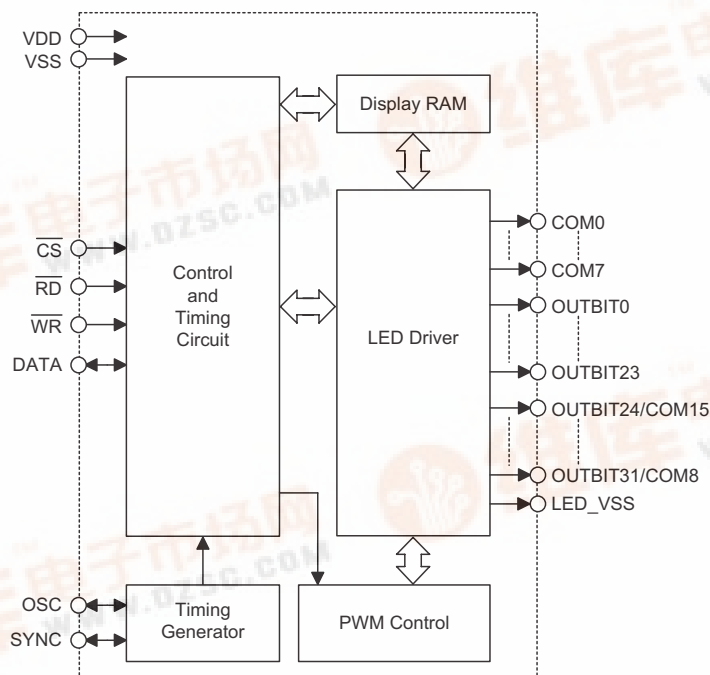

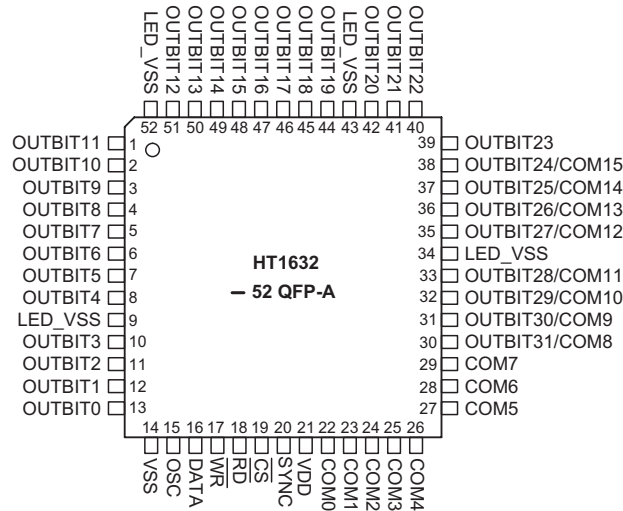
**Pin Assignment**

**Pin Description**

Pad Name	I/O	Description
OUTBIT0~OUTBIT23	O	Line drivers. These pins drive the LEDs.
OUTBIT24/COM15~OUTBIT31/COM8	O	Drive LED output or Common output
COM0~COM7	O	Common outputs
SYNC	I/O	Cascade synchronization input and output
OSC	I/O	If the system clock is sourced from an external clock source, the external clock source should be connected to this pad. If the on-chip RC oscillator is selected, this pad can be connected to a high or low level. If the cascade mode is selected, this pad is the driver clock signal.
DATA	I/O	Serial data input or output with pull-high resistor
$\overline{\text{WR}}$	I	WRITE clock input with pull-high resistor Data on the DATA lines are latched into the HT1632 on the rising edge of the $\overline{\text{WR}}$ signal.
$\overline{\text{RD}}$	I	READ clock input with pull-high resistor. The HT1632 RAM data is clocked out on the falling edge of the RD signal. The clocked out data will appear on the DATA line. The host controller can use the next rising edge to latch the clocked out data.
$\overline{\text{CS}}$	I	Chip select input with pull-high resistor When the $\overline{\text{CS}}$ line is high, the data and command read from or written to the HT1632 is disabled, and the serial interface circuit is also reset. If $\overline{\text{CS}}$ is low, the data and command transmission between the host controller and the HT1632 are all enabled.
LED_VSS	—	Negative power supply for driver circuit, ground.
VSS	—	Negative power supply for logic circuit, ground.
VDD	—	Positive power supply for logic and driver circuit.

**Absolute Maximum Ratings**

Supply Voltage ..... $V_{SS}-0.3V$  to  $V_{SS}+5.5V$       Storage Temperature ..... $-50^{\circ}C$  to  $125^{\circ}C$   
 Input Voltage..... $V_{SS}-0.3V$  to  $V_{DD}+0.3V$       Operating Temperature..... $-40^{\circ}C$  to  $85^{\circ}C$

Note: These are stress ratings only. Stresses exceeding the range specified under "Absolute Maximum Ratings" may cause substantial damage to the device. Functional operation of this device at other conditions beyond those listed in the specification is not implied and prolonged exposure to extreme conditions may affect device reliability.

**D.C. Characteristics**
 $T_a=25^{\circ}C$ 

Symbol	Parameter	Test Conditions		Min.	Typ.	Max.	Unit
		$V_{DD}$	Conditions				
$V_{DD}$	Operating Voltage	—	—	2.4	5	5.5	V
$I_{DD}$	Operating Current	5V	No load, LED ON, on-chip RC oscillator	—	—	10	mA
$I_{STB}$	Standby Current	5V	No load, power down mode	—	—	10	$\mu A$
$V_{IL}$	Input Low Voltage	5V	DATA, $\overline{WR}$ , $\overline{CS}$ , $\overline{RD}$	0	—	1	V
$V_{IH}$	Input High Voltage	5V	DATA, $\overline{WR}$ , $\overline{CS}$ , $\overline{RD}$	4	—	5	V
$I_{OL1}$	DATA	5V	$V_{OL}=0.5V$	1.3	2.6	—	mA
$I_{OH1}$	DATA	5V	$V_{OH}=4.5V$	-0.9	-1.8	—	mA
$I_{OL2}$	OSC, SYNC	5V	$V_{OL}=0.5V$	2.6	5.2	—	mA
$I_{OH2}$	OSC, SYNC	5V	$V_{OH}=4.5V$	-1.8	-3.6	—	mA
$I_{OL3}$	Common Sink Current	5V	$V_{OL}=0.5V$	—	50	—	mA
$I_{OH3}$	Common Source Current	5V	$V_{OH}=4.5V$	—	-20	—	mA
$I_{OL4}$	LED Out Driver	5V	$V_{OL}=0.5V$	—	50	—	mA
$R_{PH}$	Pull-high Resistor	5V	DATA, $\overline{WR}$ , $\overline{CS}$ , $\overline{RD}$	10	30	60	$k\Omega$

**A.C. Characteristics**

Ta=25°C

Symbol	Parameter	Test Conditions		Min.	Typ.	Max.	Unit
		V <sub>DD</sub>	Conditions				
f <sub>SYS</sub>	System Clock	5V	On-chip RC oscillator	—	256	—	kHz
f <sub>LED</sub>	LED Duty Cycle & Frame Frequency	5V	1/8 duty	—	97.5	—	Hz
		5V	1/16 duty	—	97.5	—	Hz
f <sub>CLK1</sub>	Serial Data Clock ( $\overline{WR}$ pin)	5V	Duty cycle 50%	4	—	300	kHz
f <sub>CLK2</sub>	Serial Data Clock ( $\overline{RD}$ pin)	5V	Duty cycle 50%	—	—	150	kHz
t <sub>CS</sub>	Serial Interface Reset Pulse Width	—	$\overline{CS}$	250	—	—	ns
t <sub>CLK</sub>	$\overline{WR}$ , $\overline{RD}$ Input Pulse Width	5V	Write mode	1.67	—	—	μs
			Read mode	3.34	—	—	
t <sub>r</sub> , t <sub>f</sub>	Rise/Fall Time Serial Data Clock Width (Figure 1)	—	—	120	—	—	ns
t <sub>su</sub>	Setup Time for DATA to $\overline{WR}$ , $\overline{RD}$ Clock Width (Figure 2)	—	—	120	—	—	ns
t <sub>h</sub>	Hold Time for DATA to $\overline{WR}$ , $\overline{RD}$ , Clock Width (Figure 2)	—	—	120	—	—	ns
t <sub>su1</sub>	Setup Time for $\overline{CS}$ to $\overline{WR}$ , $\overline{RD}$ , Clock Width (Figure 3)	—	—	100	—	—	ns
t <sub>h1</sub>	Hold Time for $\overline{CS}$ to $\overline{WR}$ , $\overline{RD}$ , Clock Width (Figure 3)	—	—	100	—	—	ns

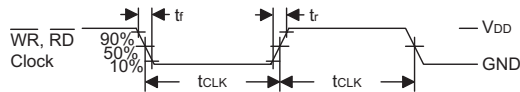
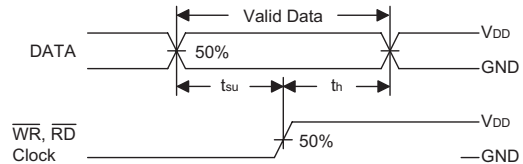
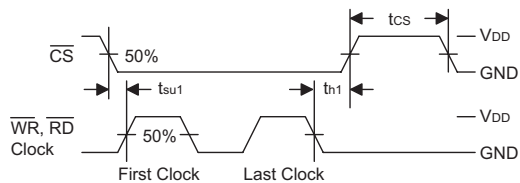
**Figure 1**

**Figure 2**

**Figure 3**

**Functional Description**
**Display Memory – RAM**

The static display memory, RAM, is organised into 64×4 bits or 96×4 bits and stores the displayed data. If 32 out bits & 8 commons is selected, the RAM size is 64×4 bits. If 24 out bits & 16 commons is selected the RAM size is

96×4 bits. The contents of the RAM are directly mapped to the contents of the LED driver. Data in the RAM can be accessed by the READ, WRITE, and READ-MODIFY-WRITE commands. The following table shows the mapping from the RAM to the LED pattern:

	Com7	Com6	Com5	Com4	Addr.	Com3	Com2	Com1	Com0	Addr.
Out0					01H					00H
Out1					03H					02H
Out2					05H					04H
Out3					07H					06H
Out4					09H					08H
Out5					0BH					0AH
Out6					0DH					0CH
Out7					0FH					0EH
Out8					11H					10H
Out9					13H					12H
Out10					15H					14H
Out11					17H					16H
Out12					19H					18H
Out13					1BH					1AH
Out14					1DH					1CH
Out15					1FH					1EH
Out16					21H					20H
Out17					23H					22H
Out18					25H					24H
Out19					27H					26H
Out20					29H					28H
Out21					2BH					2AH
Out22					2DH					2CH
Out23					2FH					2EH
Out24					31H					30H
Out25					33H					32H
Out26					35H					34H
Out27					37H					36H
Out28					39H					38H
Out29					3BH					3AH
Out30					3DH					3CH
Out31					3FH					3EH
	D3	D2	D1	D0	Data	D3	D2	D1	D0	Data

**32 Outbits & 8 Common for 64×4 Display RAM**

	Com15	Com14	Com13	Com12	Addr.	.....	Com3	Com2	Com1	Com0	Addr.
Out0					03H						00H
Out1					07H						04H
Out2					0BH						08H
Out3					0FH						0CH
Out4					13H						10H
Out5					17H						14H
Out6					1BH						18H
Out7					1FH						1CH
Out8					23H						20H
Out9					27H						24H
Out10					2BH						28H
Out11					2FH	.....					2CH
Out12					33H						30H
Out13					37H						34H
Out14					3BH						38H
Out15					3FH						3CH
Out16					43H						40H
Out17					47H						44H
Out18					4BH						48H
Out19					4FH						4CH
Out20					53H						50H
Out21					57H						54H
Out22					5BH						58H
Out23					5FH	.....					5CH
	D3	D2	D1	D0	Data		D3	D2	D1	D0	Data

**24 Outbits & 16 Common for 96×4 Display RAM**

### System Oscillator

The HT1632 system clock is used to generate the time base clock frequency, LED-driving clock. The clock may be sourced from an on-chip RC oscillator (256kHz), or an external clock using the S/W setting. The configuration of the system oscillator is as shown. After the SYS DIS command is executed, the system clock will stop and the LED duty cycle generator will turn off. This command is, however, available only for the on-chip RC oscillator. Once the system clock stops, the LED display will become blank, and the time base will also lose its function. The LED OFF command is used to turn the LED duty cycle generator off. After the LED duty cycle generator switches off by issuing the LED OFF command, using the SYS DIS command reduces power consumption, serving as a system power down command. But if the external clock source is chosen as the system clock, using the SYS DIS command can neither turn the oscillator off nor execute the power down mode. The crystal oscillator option can be applied to connect an external frequency source to the OSC pin. In this case, the system fails to enter the power down mode, similar to the case in the external clock source operation. At the initial system power on, the HT1632 is in the SYS DIS state.

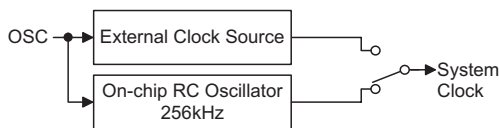

**System Oscillator Configuration**

### LED Driver

The HT1632 has a 256 (32×8) and 384 (24×16) pattern LED driver. It can be configured in a 32×8 or 24×16 pattern and common pad N-MOS open drain output or P-MOS open drain output LED driver using the S/W configuration. This feature makes the HT1632 suitable for multiple LED applications. The LED-driving clock is derived from the system clock. The driving clock frequency is always 256kHz, an on-chip RC oscillator frequency, or an external frequency. The LED corresponding commands are summarized in the table. The bold form of 1 0 0, namely 1 0 0, indicates the command mode ID. If successive commands have been issued, the command mode ID except for the first command will be omitted. The LED OFF command turns the LED display off by disabling the LED duty cycle generator. The LED ON command, on the other hand, turns the LED display on by enabling the LED duty cycle generator.

Name	Command Code	Function
LED OFF	<b>1000000010X</b>	Turn off LED outputs
LED ON	<b>1000000011X</b>	Turn on LED outputs
Commons Option	<b>1000010abXXX</b>	ab=00: N-MOS open drain output and 8 common option ab=01: N-MOS open drain output and 16 common option ab=10: P-MOS open drain output and 8 common option ab=11: P-MOS open drain output and 16 common option

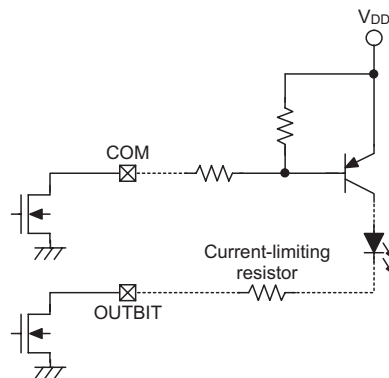

**NMOS Open Drain Driving Mode Configuration**

LED Color	Current-limiting Resistor
Red	120Ω
Green	100Ω

**Recommended Current-limiting Resistor for NMOS Open Drain Driving Mode**

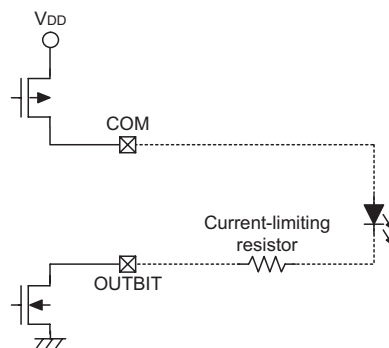

**PMOS Open Drain Driving Mode Configuration**

**Blinker**

The HT1632 has display blinking capabilities. The blink function generates all LED blinking. The blink rates is 0.25ms LED on and 0.25ms LED off for one blinking period. This blinking function can be effectively performed by setting the BLINK ON or BLINK OFF command.

**Command Format**

The SW setting can configure the HT1632. There are two mode commands to configure the HT1632 resources and to transfer the LED display data. The configuration mode of the HT1632 is known as the command mode, with a command mode ID of 1 0 0. The command mode consists of a system configuration command, a system frequency selection command, a LED configuration command, and an operating command. The data mode, on the other hand, includes READ, WRITE, and READ-MODIFY-WRITE operations.

The following are the data mode ID and the command mode ID:

Operation	Mode	ID
READ	Data	1 1 0
WRITE	Data	1 0 1
READ-MODIFY-WRITE	Data	1 0 1
COMMAND	Command	1 0 0

The mode command should be issued before the data or command is transferred. If successive commands have been issued, the command mode ID, namely 1 0 0, can be omitted. While the system is operating in the non-successive command or the non-successive address data mode, the  $\overline{CS}$  pin should be set to "1" and the previous operation mode will be reset also. Once the  $\overline{CS}$  pin returns to "0", a new operation mode ID should be issued first.

**Interfacing**

Only four lines are required to interface to the HT1632. The  $\overline{CS}$  line is used to initialise the serial interface circuit and to terminate the communication between the host controller and the HT1632. If the  $\overline{CS}$  pin is set to 1, the data and command issued between the host controller and the HT1632 are first disabled and then initialised. Before issuing a mode command or mode switching, a high level pulse is required to initialise the serial interface of the HT1632. The DATA line is the serial data input/output line. Data to be read or written or commands to be written have to be passed through the DATA line. The  $\overline{RD}$  line is the READ clock input. Data in the RAM is clocked out on the falling edge of the  $\overline{RD}$  signal, and the clocked out data will then appear on the DATA line. It is recommended that the host controller reads in the correct data during the interval between the rising edge and the next falling edge of the  $\overline{RD}$  signal. The  $\overline{WR}$  line is the WRITE clock input. The data, address, and command on the DATA line are all clocked into the HT1632 on the rising edge of the  $\overline{WR}$  signal.

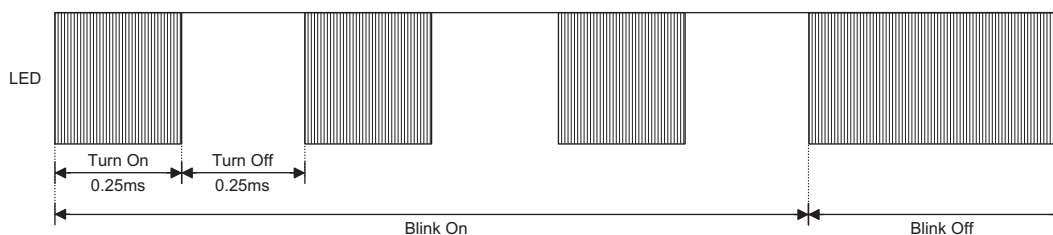

**Example of Waveform for Blinker**

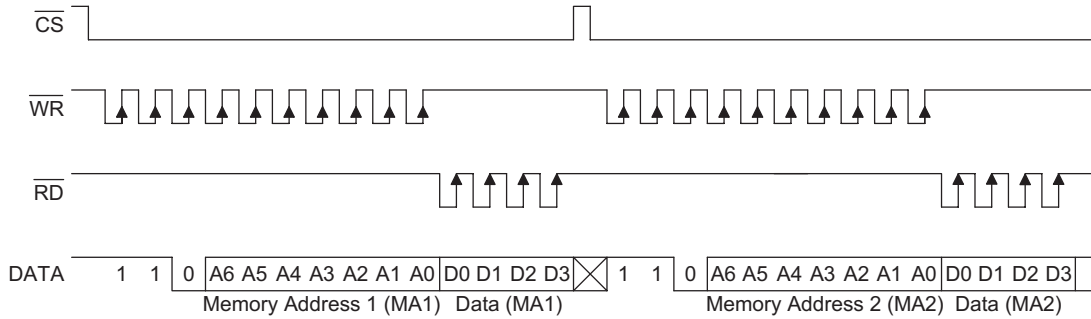
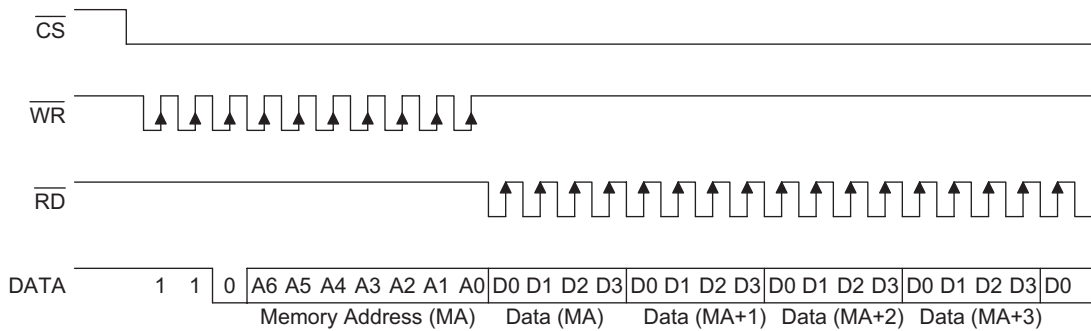
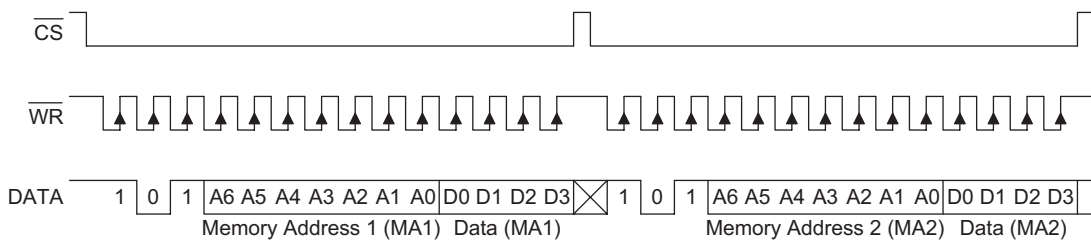
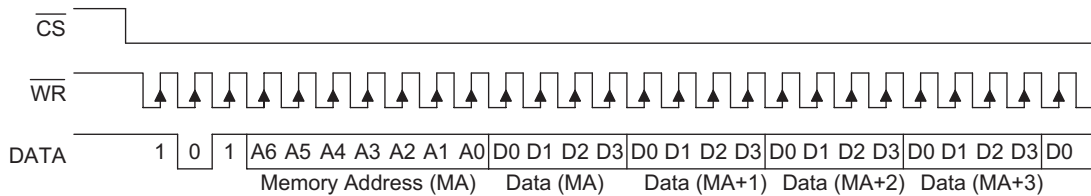

**Timing Diagrams**
**READ Mode – Command Code = 1 1 0**

**READ Mode – Successive Address Reading**

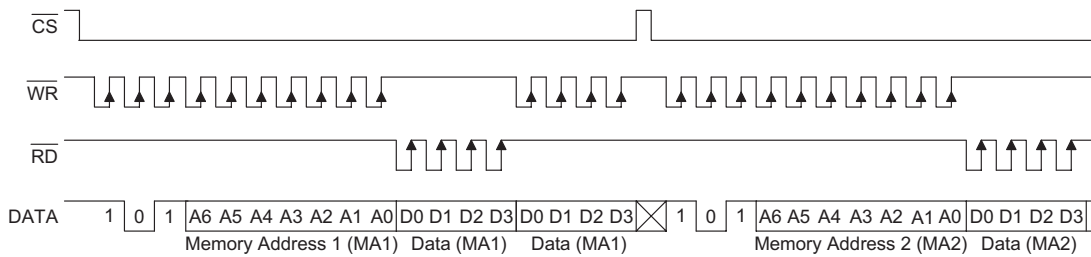
**WRITE Mode – Command Code = 1 0 1**

**WRITE Mode – Successive Address Writing**

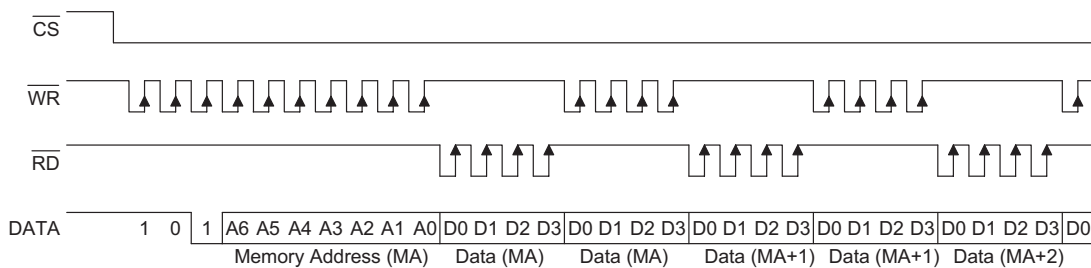
**READ-MODIFY-WRITE Mode – Command Code = 1 0 1**



**READ-MODIFY-WRITE Mode – Successive Address Accessing**



**Command Mode – Command Code = 1 0 0**

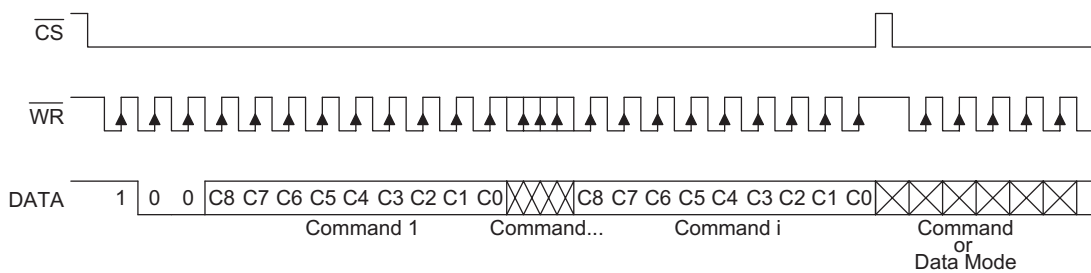

**Mode – Data and Command Mode**

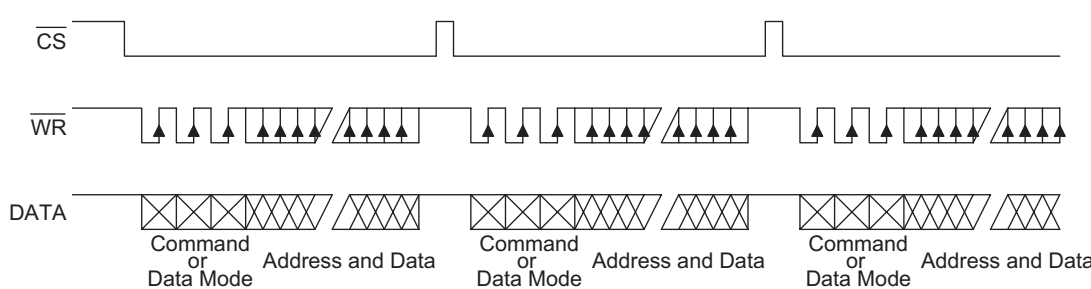

**Application Circuits**

**Single Connect Example for 32 Outbits & 8 Commons**

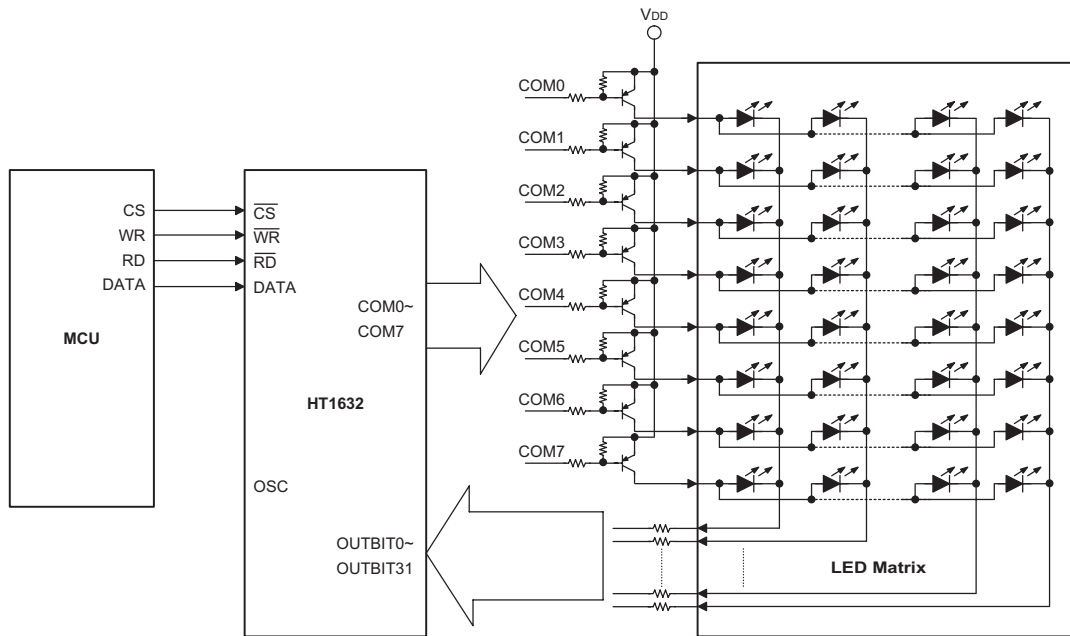

Note: Common & outbit are all NMOS open drain output structures and only supply sink current.

**Single Connect Example for 24 Outbits & 16 Commons**

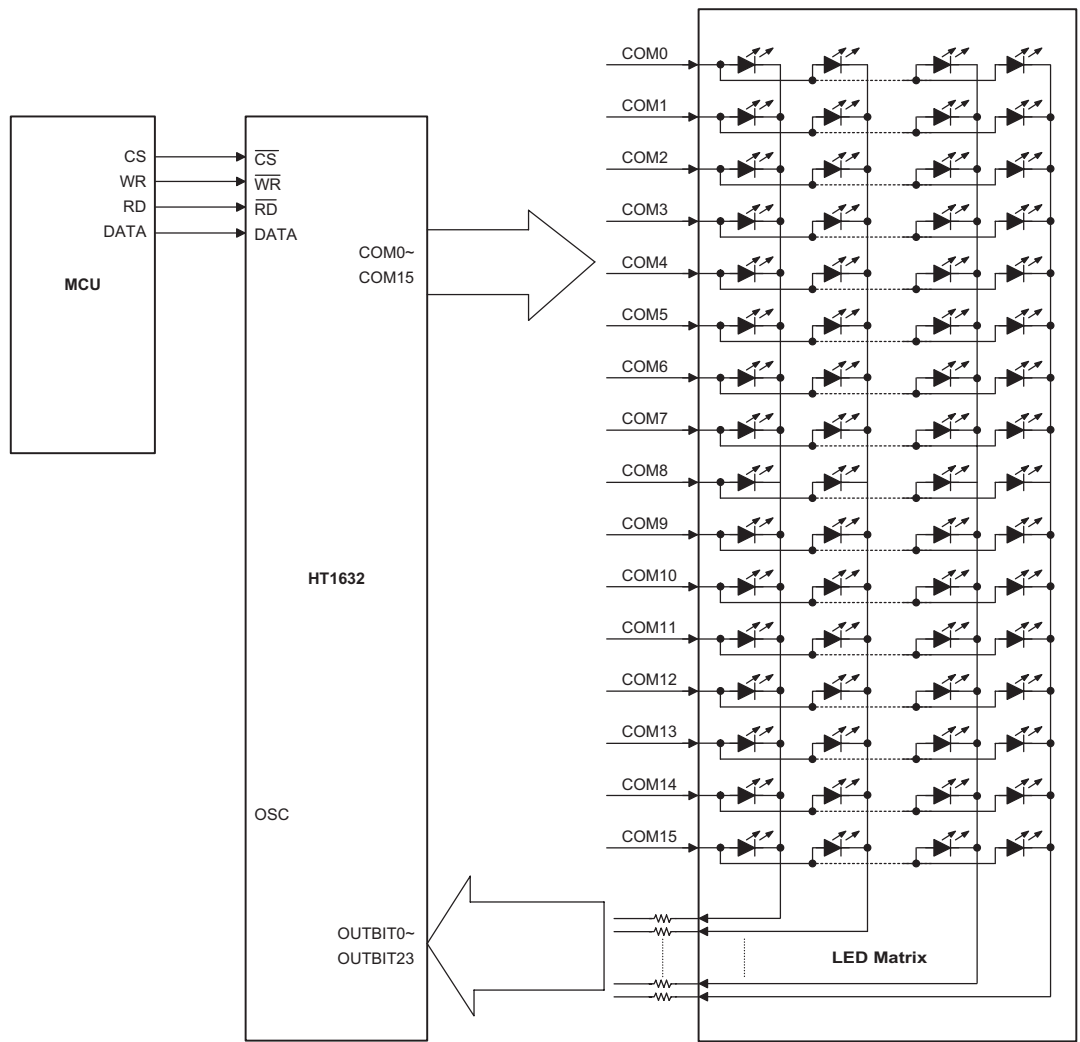

Note: Outbit are NMOS open drain output structures and only supply sink current, common are PMOS open drain output structures and only supply source current

**Cascade Connect Example for 32 Outbits & 8 Commons**

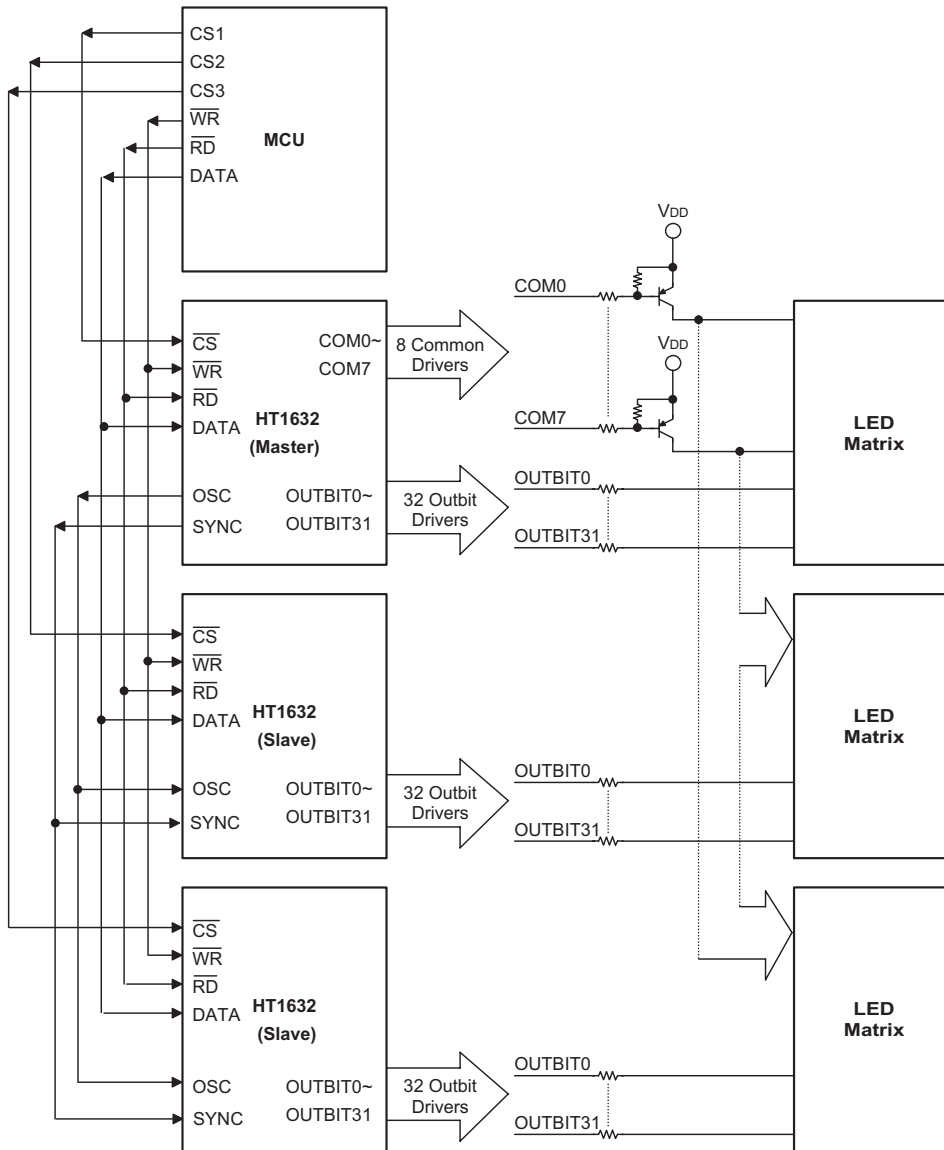

Note: It also can set cascade mode by software. User must set the Slaves in external clock mode with command. The  $\overline{CS}$  pin must be connected to MCU individually for independent read-write.

Cascade Control Flow

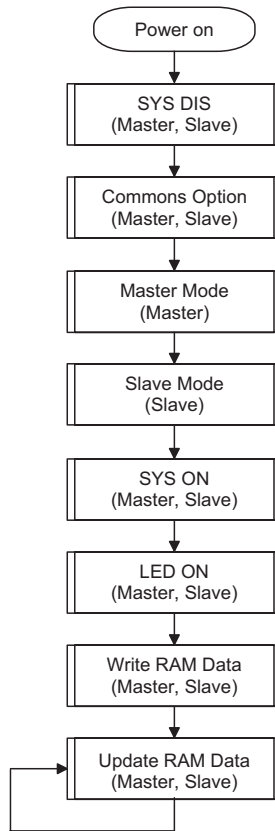

**Command Summary**

Name	ID	Command Code	D/C	Function	Def.
READ	1 1 0	A6A5A4A3A2A1A0D0D1D2D3	D	Read data from the RAM	
WRITE	1 0 1	A6A5A4A3A2A1A0D0D1D2D3	D	Write data to the RAM	
READ-MODIFY-WRITE	1 0 1	A6A5A4A3A2A1A0D0D1D2D3	D	Read and Write data to the RAM	
SYS DIS	1 0 0	0000-0000-X	C	Turn off both system oscillator and LED duty cycle generator	Yes
SYS EN	1 0 0	0000-0001-X	C	Turn on system oscillator	
LED OFF	1 0 0	0000-0010-X	C	Turn off LED duty cycle generator	Yes
LED ON	1 0 0	0000-0011-X	C	Turn on LED duty cycle generator	
BLINK OFF	1 0 0	0000-1000-X	C	Turn off blinking function	Yes
BLINK ON	1 0 0	0000-1001-X	C	Turn on blinking function	
SLAVE MODE	1 0 0	0001-00XX-X		Set slave mode and clock source from external clock	
MASTER MODE	1 0 0	0001-01XX-X		Set master mode and clock source on-chip RC oscillator, the system clock output to OSC pin	
RC	1 0 0	0001-10XX-X	C	System clock source, on-chip RC oscillator	Yes
EXT CLK	1 0 0	0001-11XX-X	C	System clock source, external clock source	
COMMONS OPTION	1 0 0	0010-abXX-X	C	ab=00: N-MOS open drain output and 8 common option ab=01: N-MOS open drain output and 16 common option ab=10: P-MOS open drain output and 8 common option ab=11: P-MOS open drain output and 16 common option	ab =10
PWM Duty	1 0 0	101X-0000-X	C	PWM 1/16 duty	
	1 0 0	101X-0001-X	C	PWM 2/16 duty	
	1 0 0	101X-0010-X	C	PWM 3/16 duty	
	1 0 0	101X-0011-X	C	PWM 4/16 duty	
	1 0 0	101X-0100-X	C	PWM 5/16 duty	
	1 0 0	101X-0101-X	C	PWM 6/16 duty	
	1 0 0	101X-0110-X	C	PWM 7/16 duty	
	1 0 0	101X-0111-X	C	PWM 8/16 duty	
	1 0 0	101X-1000-X	C	PWM 9/16 duty	
	1 0 0	101X-1001-X	C	PWM 10/16 duty	
	1 0 0	101X-1010-X	C	PWM 11/16 duty	
	1 0 0	101X-1011-X	C	PWM 12/16 duty	
	1 0 0	101X-1100-X	C	PWM 13/16 duty	
	1 0 0	101X-1101-X	C	PWM 14/16 duty	
	1 0 0	101X-1110-X	C	PWM 15/16 duty	
	1 0 0	101X-1111-X	C	PWM 16/16 duty	

Package Information

52-pin QFP (14×14) Outline Dimensions

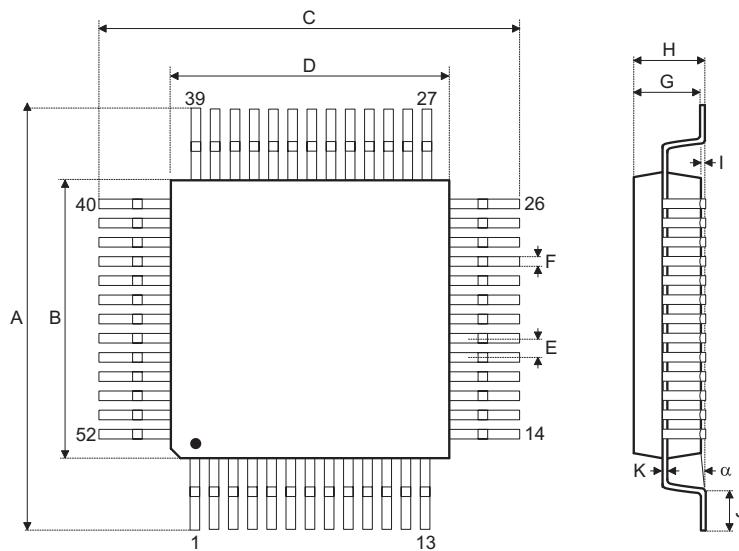

Symbol	Dimensions in mm		
	Min.	Nom.	Max.
A	17.3	—	17.5
B	13.9	—	14.1
C	17.3	—	17.5
D	13.9	—	14.1
E	—	1	—
F	—	0.4	—
G	2.5	—	3.1
H	—	—	3.4
I	—	0.1	—
J	0.73	—	1.03
K	0.1	—	0.2
$\alpha$	0°	—	7°



**Holtek Semiconductor Inc. (Headquarters)**

No.3, Creation Rd. II, Science Park, Hsinchu, Taiwan  
Tel: 886-3-563-1999  
Fax: 886-3-563-1189  
<http://www.holtek.com.tw>

**Holtek Semiconductor Inc. (Taipei Sales Office)**

4F-2, No. 3-2, YuanQu St., Nankang Software Park, Taipei 115, Taiwan  
Tel: 886-2-2655-7070  
Fax: 886-2-2655-7373  
Fax: 886-2-2655-7383 (International sales hotline)

**Holtek Semiconductor Inc. (Shanghai Sales Office)**

7th Floor, Building 2, No.889, Yi Shan Rd., Shanghai, China 200233  
Tel: 86-21-6485-5560  
Fax: 86-21-6485-0313  
<http://www.holtek.com.cn>

**Holtek Semiconductor Inc. (Shenzhen Sales Office)**

5/F, Unit A, Productivity Building, Cross of Science M 3rd Road and Gaoxin M 2nd Road, Science Park, Nanshan District, Shenzhen, China 518057  
Tel: 86-755-8616-9908, 86-755-8616-9308  
Fax: 86-755-8616-9722

**Holtek Semiconductor Inc. (Beijing Sales Office)**

Suite 1721, Jinyu Tower, A129 West Xuan Wu Men Street, Xicheng District, Beijing, China 100031  
Tel: 86-10-6641-0030, 86-10-6641-7751, 86-10-6641-7752  
Fax: 86-10-6641-0125

**Holtek Semiconductor Inc. (Chengdu Sales Office)**

709, Building 3, Champagne Plaza, No.97 Dongda Street, Chengdu, Sichuan, China 610016  
Tel: 86-28-6653-6590  
Fax: 86-28-6653-6591

**Holtek Semiconductor (USA), Inc. (North America Sales Office)**

46729 Fremont Blvd., Fremont, CA 94538  
Tel: 1-510-252-9880  
Fax: 1-510-252-9885  
<http://www.holtek.com>

Copyright © 2007 by HOLTEK SEMICONDUCTOR INC.

The information appearing in this Data Sheet is believed to be accurate at the time of publication. However, Holtek assumes no responsibility arising from the use of the specifications described. The applications mentioned herein are used solely for the purpose of illustration and Holtek makes no warranty or representation that such applications will be suitable without further modification, nor recommends the use of its products for application that may present a risk to human life due to malfunction or otherwise. Holtek's products are not authorized for use as critical components in life support devices or systems. Holtek reserves the right to alter its products without prior notification. For the most up-to-date information, please visit our web site at <http://www.holtek.com.tw>.