



HT6221/HT6222 Multi-Purpose Encoders

Features

- Operating voltage: 1.8V~3.5V
- DOUT with 38kHz carrier for IR medium
- Low standby current
- Minimum transmission word: one word
- 455kHz ceramic resonator or crystal
- 16-bit address codes
- 8-bit data codes
- PPM code method
- Three double-active keys
- Maximum active keys
 - HT6221: 32 keys
 - HT6222: 64 keys
- Low power and high noise immunity CMOS technology
- HT6221: 20-pin SOP package
HT6222: 24-pin SOP package

Applications

- Television and video cassette recorder controllers
- Burglar alarm systems
- Smoke and fire alarm systems
- Garage door controllers
- Car door controllers
- Car alarm systems
- Security systems
- Other remote control systems

General Description

The HT6221/HT6222 are CMOS LSI encoders designed for use in remote control systems. They are capable of encoding 16-bit address codes and 8-bit data codes. Each address/data input can be set to one of the two logic states, 0 and 1.

The HT6221/HT6222 contain 32 keys (K1~K32) and 64 keys (K1~K64), respectively. When one of the keys is triggered, the programmed address/data is transmitted together with the header bits via an IR (38kHz carrier) transmission medium.

Block Diagram

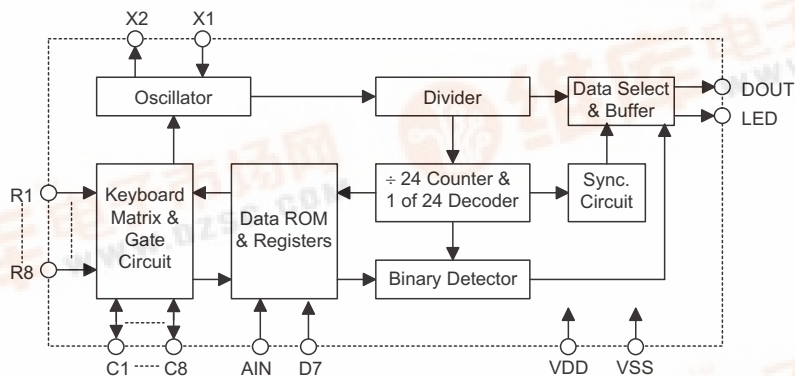

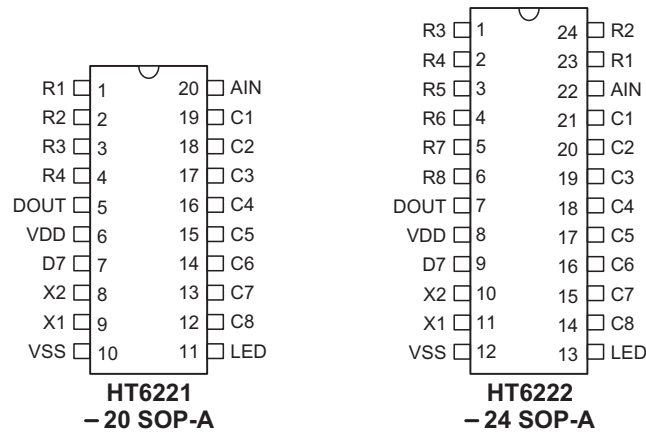
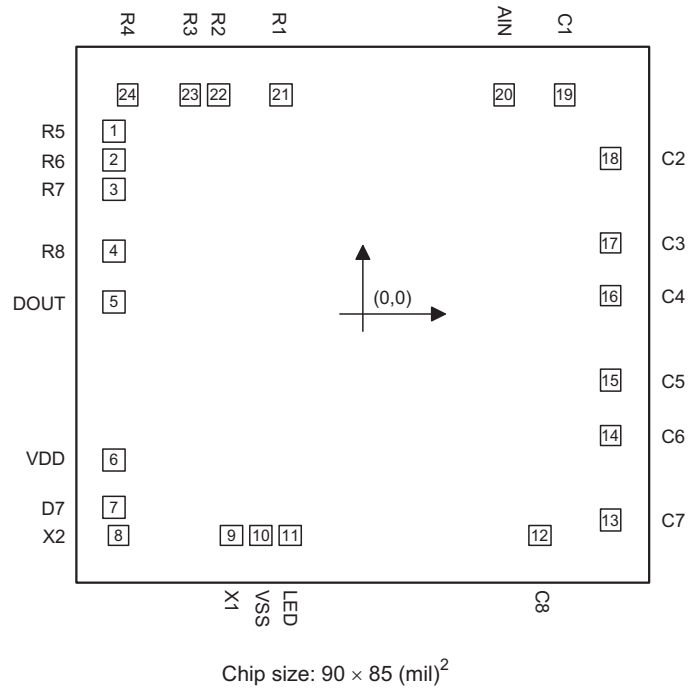
Pin Assignment

Pad Assignment

* The IC substrate should be connected to VDD in the PCB layout artwork.

Pad Coordinates

Unit: mil

Pad No.	X	Y	Pad No.	X	Y
1	-38.44	28.57	13	38.21	-32.09
2	-38.44	24.06	14	38.21	-18.90
3	-38.44	19.55	15	38.21	-10.33
4	-38.44	9.91	16	38.21	2.87
5	-38.44	1.95	17	38.21	11.13
6	-38.44	-22.72	18	38.21	24.33
7	-38.44	-30.03	19	31.14	34.20
8	-37.83	-34.54	20	21.80	34.19
9	-20.31	-34.54	21	-12.62	34.19
10	-15.72	-34.54	22	-22.26	34.19
11	-11.21	-34.54	23	-26.77	34.19
12	27.27	-34.54	24	-36.41	34.19

Pin Description
HT6222

Pin No.	Pin Name	I/O	Internal Connection	Description
1~6	R3~R8	I	CMOS IN, Pull-low	Row control for keyboard matrix, active high
7	DOUT	O	CMOS OUT	Serial data output pin, with a 38kHz carrier
8	VDD	—	—	Positive power supply, 1.8V~3.5V for normal operation
9	D7	I	CMOS IN	Most significant data bit (D7) code setting
10	X2	O	OSCILLATOR	455kHz resonator oscillator output
11	X1	I	OSCILLATOR	455kHz resonator oscillator input
12	VSS	—	—	Negative power supply, ground
13	LED	O	CMOS OUT	Transmission enable indicator output
14~21	C8~C1	I/O	CMOS IN/OUT, Pull-low	Column control for keyboard matrix
22	AIN	I	CMOS IN, Pull-high Pull-low	Low byte address codes (8 bits) scan input
23~24	R1~R2	I	CMOS IN, Pull-low	Row control for keyboard matrix, active high

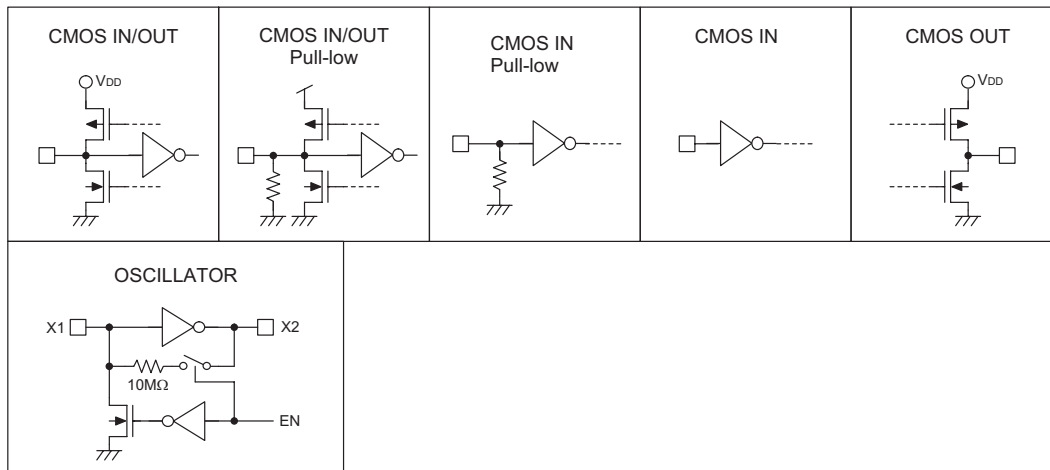
Approximate Internal Connection Circuits

Absolute Maximum Ratings

Supply Voltage	$V_{SS}-0.3V$ to $V_{SS}+6V$	Storage Temperature	$-50^{\circ}C$ to $125^{\circ}C$
Input Voltage.....	$V_{SS}-0.3V$ to $V_{DD}+0.3V$	Operating Temperature.....	$-20^{\circ}C$ to $75^{\circ}C$

Note: These are stress ratings only. Stresses exceeding the range specified under "Absolute Maximum Ratings" may cause substantial damage to the device. Functional operation of this device at other conditions beyond those listed in the specification is not implied and prolonged exposure to extreme conditions may affect device reliability.

Electrical Characteristic
 $T_a=25^{\circ}C$

Symbol	Parameter	Test Conditions		Min.	Typ.	Max.	Unit
		V_{DD}	Conditions				
V_{DD}	Operating Voltage	—	—	1.8	3	3.5	V
I_{STB}	Standby Current	3V	Oscillator stops	—	0.1	1.0	μA
I_{DD}	Operating Current	3V	$f_{OSC}=455kHz$, no load	—	200	400	μA
I_{OH1}	Output Source Current for DOUT	3V	$V_O=2.7V$	-2.0	-4.0	—	mA
I_{OL1}	Output Sink Current for DOUT	3V	$V_O=0.3V$	50	100	—	μA
I_{OH2}	Output Source Current for LED	3V	$V_O=2.7V$	-10	-60	—	μA
I_{OL2}	Output Sink Current for LED	3V	$V_O=0.3V$	1.2	2.0	—	mA
I_{OH3}	Output Source Current for C1~C8	3V	$V_O=2.7V$	-0.6	-2.0	—	mA
I_{OL3}	Output Sink Current for C1~C8	3V	$V_O=0.3V$	10	30	—	μA
V_{IH1}	Input High Voltage for R1~R8	3V	—	1.9	—	3.0	V
V_{IL1}	Input Low Voltage for R1~R8	3V	—	0	—	0.8	V
V_{IH2}	Input High Voltage for C1~C8	3V	—	1.6	—	3.0	V
V_{IL2}	Input Low Voltage for C1~C8	3V	—	0	—	0.6	V
V_{IH3}	Input High Voltage for AIN	3V	—	1.25	—	3.0	V
V_{IL3}	Input Low Voltage for AIN	3V	—	0	—	0.6	V
R_{PH1}	Input Pull-high Resistance for AIN	3V	$V_{IN}=0V$	100	200	400	$k\Omega$
R_{PL1}	Input Pull-low Resistance for AIN	3V	$V_{IN}=3V$	70	150	250	$k\Omega$
R_{PL2}	Input Pull-low Resistance for R1~R8	3V	$V_{IN}=3V$	120	200	320	$k\Omega$
R_{PL3}	Input Pull-low Resistance for C1~C8	3V	$V_{IN}=3V$	300	500	1500	$k\Omega$
f_{OSC}	System Frequency	—	455kHz ceramic resonator	—	455	—	kHz

Functional Description

Keyboard Scan

The HT6221/HT6222 remain in the halt mode during the standby state (at this time, the oscillator stops, and the standby current $<1\mu\text{A}$). The HT6221 consists of 32 active keys, and the HT6222 has 64 active keys. The keyboard forms of the HT6221/ HT6222 are shown below.

- The HT6221 keyboard form

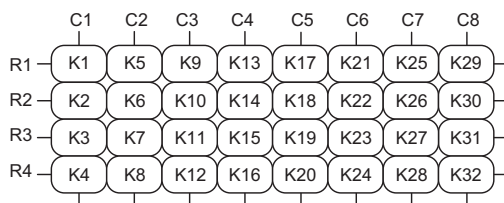

- The HT6222 keyboard form

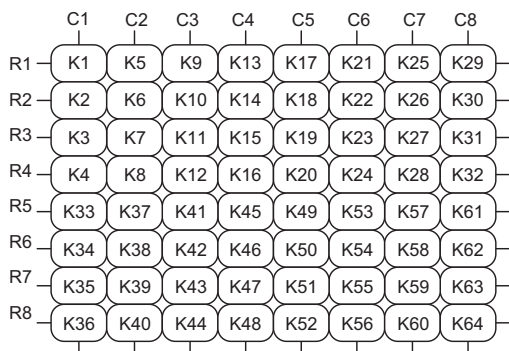

When one of the keys (32 or 64 keys) is triggered for over 36ms, the oscillator is enabled and the chip is activated. If the key is pressed and held for 108ms or less, the 108ms transmission codes are enabled and comprised of a header code (9ms), an off code (4.5ms), low byte address codes (9ms~18ms), high byte address codes (9ms~18ms), 8-bit data codes (9ms~18ms), and the inverse codes of the 8-bit data codes (18ms~9ms). After the pressed key is held for 108ms, if the key is still held down, the transmission codes turn out to be a composition of header (9ms) and off codes (2.5ms) only.

To avoid mistakes made by keyboard scanning or simultaneous two-key inputs (except for the three double-key active functions (K21+K22, K21+K23, and K21+K24), the HT6221/HT6222 are facilitated with 36ms starting time.

The HT6221/HT6222 also provide three double-key active functions (K21+K22, K21+K23, and K21+K24) for tape deck recording operations. The double-key operation rules are shown in timing 4 and timing 6.

Transmission Codes

The transmission codes of the HT6221/HT6222 consist of a 9ms header code, a 4.5ms off code, 16-bit address codes (18ms~36ms), 9ms~18ms 8-bit data codes, and the inverse code of the 8-bit data codes. The following is an illustration of the transmission codes:

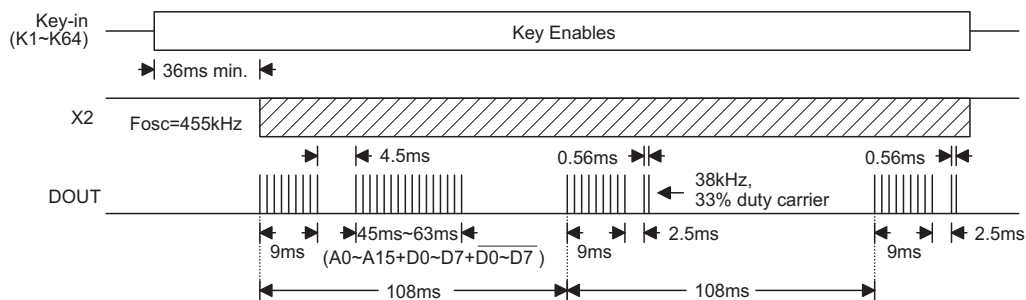

Output format for the DOUT

The output code carrier of the DOUT pin is shown in Timing 2:

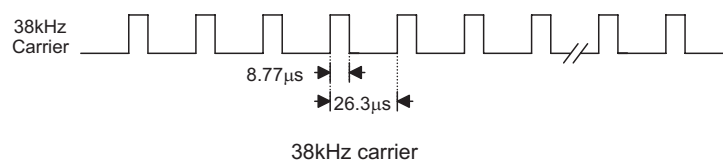

The transmission codes employ the PPM (Pulse Position Modulation) method to represent their two logic states by "0" (1.12ms) and "1" (2.24ms) as shown in Timing 3:

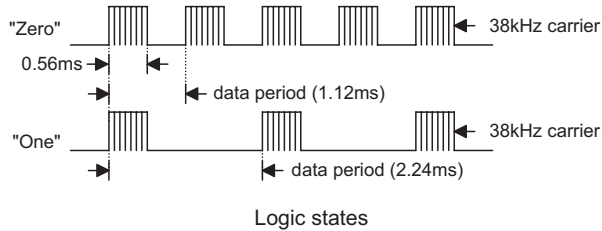

• Setting the address codes (A0~A15)

The algorithm rule of the address codes (A0~A15) can be selected by mask option.

In this case, the 16-bit on-chip MASK ROM (ROM1 and ROM2) are available, and the value of ROM1 (8 bits) and ROM2 (8 bits) are decided by one MASK LAYER. The current value of ROM1 and ROM2 are both "00H". The A0~A7 are set by logical OR between

the external switch S0~S7 and the ROM1. The A8~A15 equal some bits inverted to A0~A7, the inversion are decided by Logical OR between the external switch S8~S15 and the ROM2.

For example:

The following is an illustration of these rules in selecting the address codes (A0~A15).

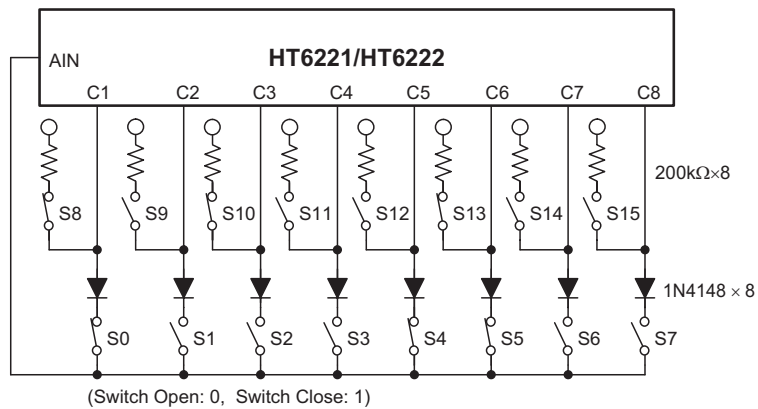

External Switch S0~S15:

1	0	0	0	1	1	0	0	1	0	1	0	0	1	0	0
---	---	---	---	---	---	---	---	---	---	---	---	---	---	---	---

On-chip ROM1, ROM2:

0	0	0	0	0	0	0	0	0	0	0	0	0	0	0	0
---	---	---	---	---	---	---	---	---	---	---	---	---	---	---	---

bit0 bit7 bit0 bit7

S0~S7 OR ROM1
A0~A7:

1	0	0	0	1	1	0	0
---	---	---	---	---	---	---	---

S8~S15 OR ROM2
A8'~A15':

1	0	1	0	0	1	0	0
---	---	---	---	---	---	---	---

A0 A1 A2 A3 A4 A5 A6 A7
A8~A15:

1	1	0	1	0	1	1	1
---	---	---	---	---	---	---	---

Complement (1: noninversion, 0: inversion)

- Values of the data codes (D0~D7)

The HT6221/HT6222 contain 32 and 64 active keys, respectively. Each key corresponds to a data code. For tape deck recording, the HT6221/HT6222 provide three double-key functions. The double-key, single-key, and double-key operation rules are shown in Table 3, Table 4, Timing 4, Timing 5 and Timing 6.

Table 3: Double-key data code table

KEY	Data Codes D0~D6	Data Code D7
K21+K22	1010110	0/1
K21+K23	0110110	0/1
K21+K24	1110110	0/1

Note: D7 is defined by an external switch

Table 4: K1~K64 single-key data code table

KEY	Data Codes D0~D6	Data Code D7	KEY	Data Codes D0~D6	Data Code D7
K1	0000 000	0/1	K33	0000 001	0/1
K2	1000 000	0/1	K34	1000 001	0/1
K3	0100 000	0/1	K35	0100 001	0/1
K4	1100 000	0/1	K36	1100 001	0/1
K5	0010 000	0/1	K37	0010 001	0/1
K6	1010 000	0/1	K38	1010 001	0/1
K7	0110 000	0/1	K39	0110 001	0/1
K8	1110 000	0/1	K40	1110 001	0/1
K9	0001 000	0/1	K41	0001 001	0/1
K10	1001 000	0/1	K42	1001 001	0/1
K11	0101 000	0/1	K43	0101 001	0/1
K12	1101 000	0/1	K44	1101 001	0/1
K13	0011 000	0/1	K45	0011 001	0/1
K14	1011 000	0/1	K46	1011 001	0/1
K15	0111 000	0/1	K47	0111 001	0/1
K16	1111 000	0/1	K48	1111 001	0/1
K17	0000 100	0/1	K49	0000 101	0/1
K18	1000 100	0/1	K50	1000 101	0/1
K19	0100 100	0/1	K51	0100 101	0/1
K20	1100 100	0/1	K52	1100 101	0/1
K21	0010 100	0/1	K53	0010 101	0/1
K22	1010 100	0/1	K54	1010 101	0/1
K23	0110 100	0/1	K55	0110 101	0/1
K24	1110 100	0/1	K56	1110 101	0/1
K25	0001 100	0/1	K57	0001 101	0/1
K26	1001 100	0/1	K58	1001 101	0/1
K27	0101 100	0/1	K59	0101 101	0/1
K28	1101 100	0/1	K60	1101 101	0/1
K29	0011 100	0/1	K61	0011 101	0/1
K30	1011 100	0/1	K62	1011 101	0/1
K31	0111 100	0/1	K63	0111 101	0/1
K32	1111 100	0/1	K64	1111 101	0/1

Note: D7 is defined by an external switch

D7=0 : connect to VDD

D7=1 : connect to VSS

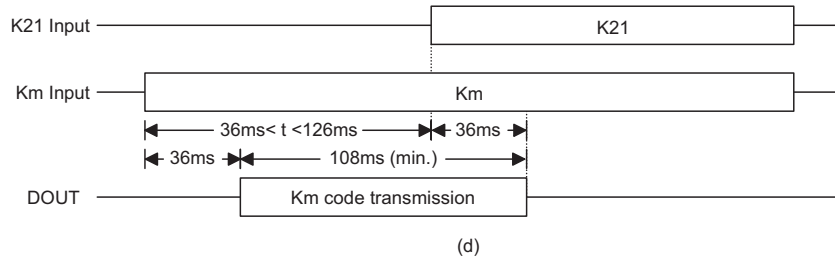
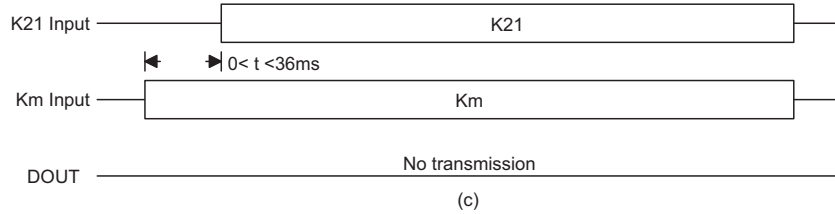
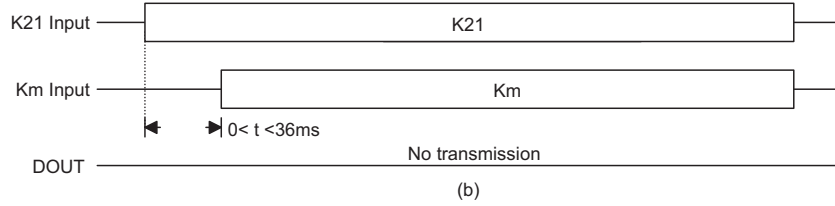
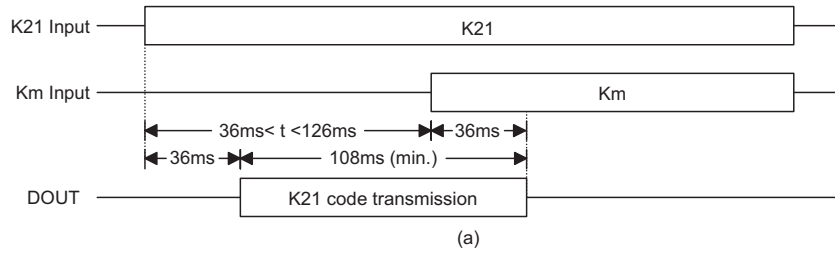

Invalid double-key input

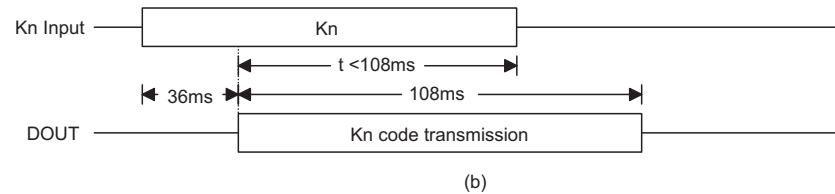
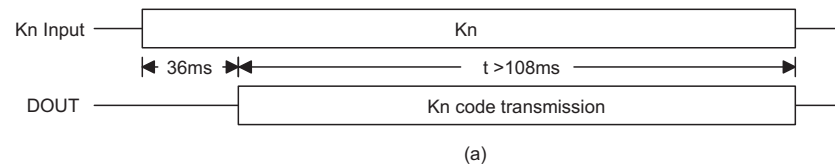

Note: Kn can be one of K1~K64

Valid single-key input

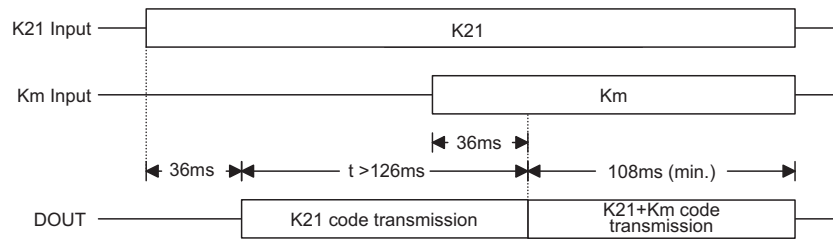

Note: Km can be one of K22~K24

Valid double-key input

DOUT and LED

After the transmission codes are sent, the DOUT pin generates transmission codes with a carrier, and the LED goes low to drive a transmission indicator.

Application Circuits

Application Circuit 1

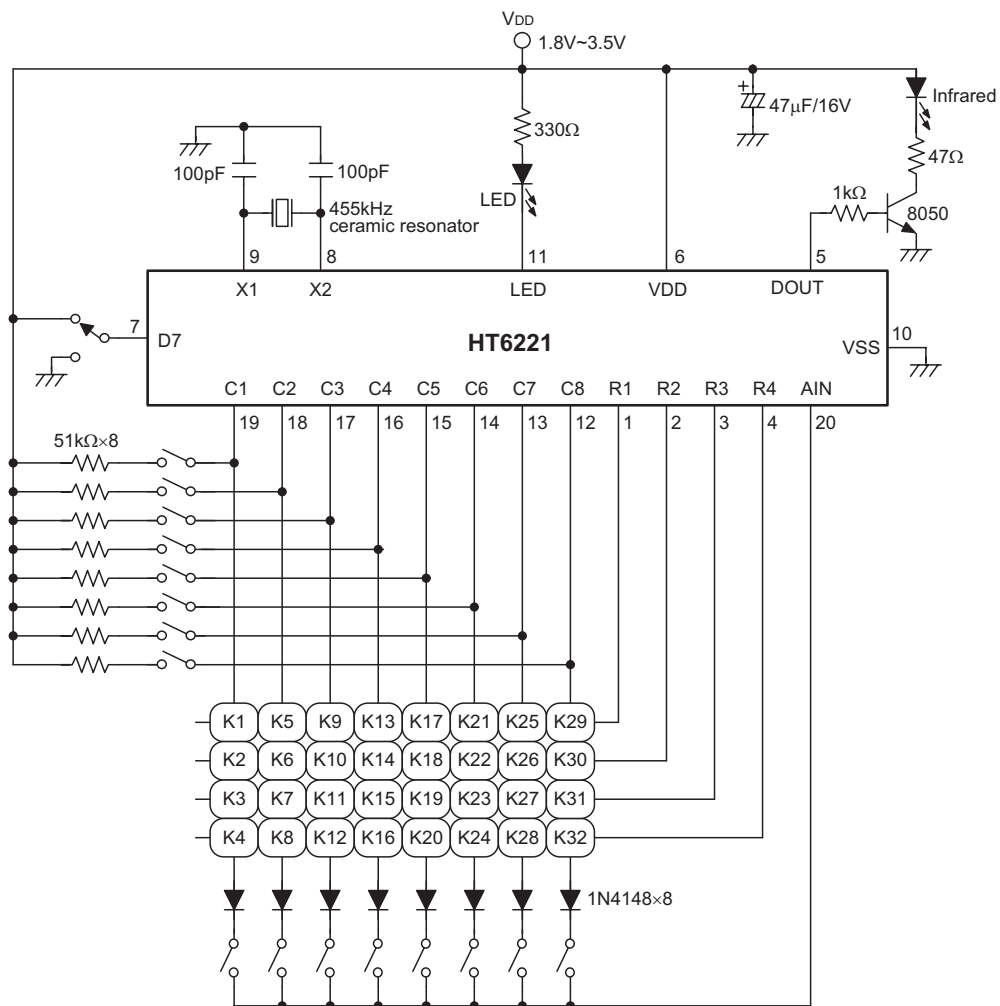

Note: Typical infrared diode: EL-1L2 (KODENSHI CORP.)

Application Circuit 2

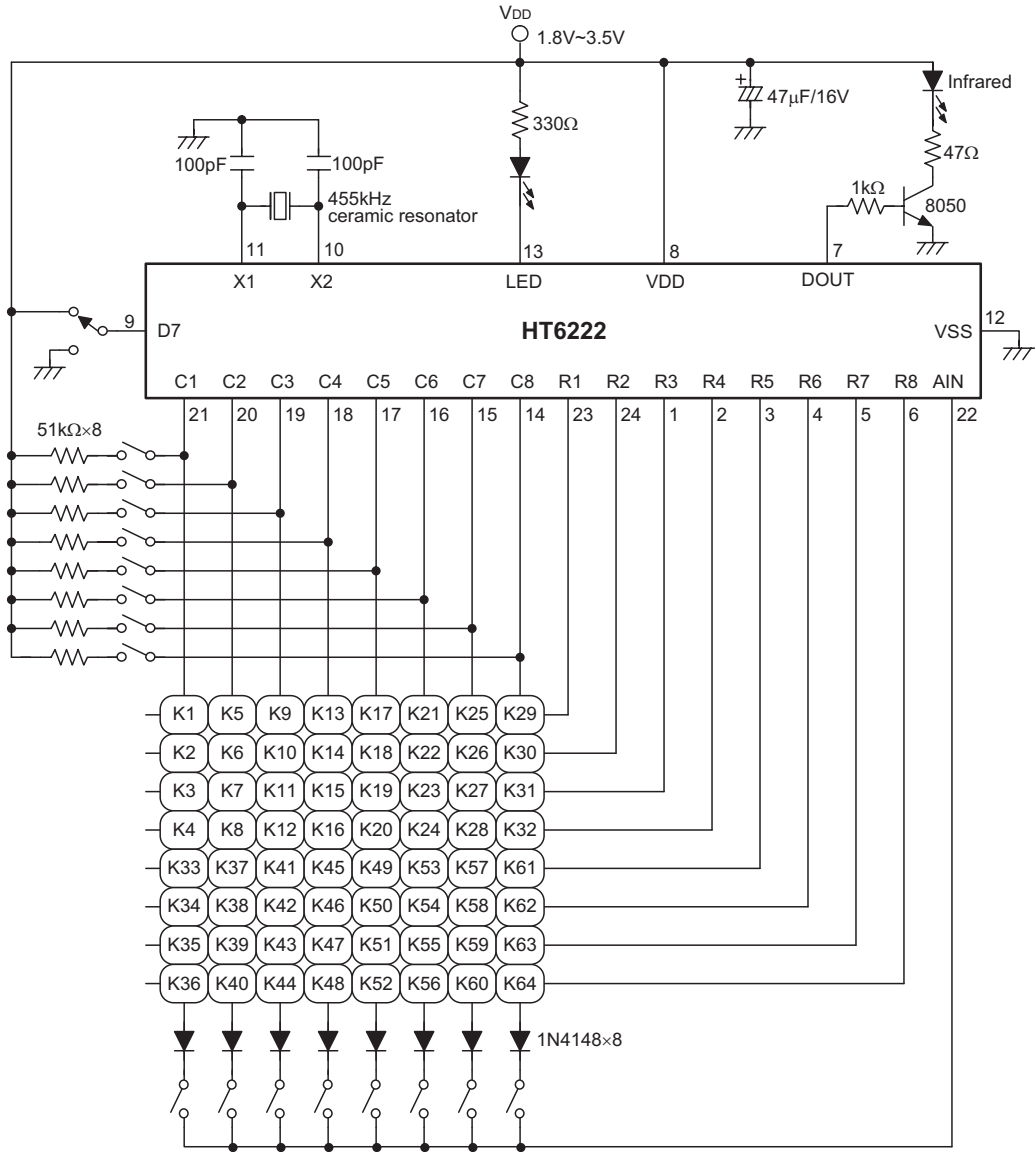

Note: Typical infrared diode: EL-1L2 (KODENSHI CORP.)

Package Information

20-pin SOP (300mil) Outline Dimensions

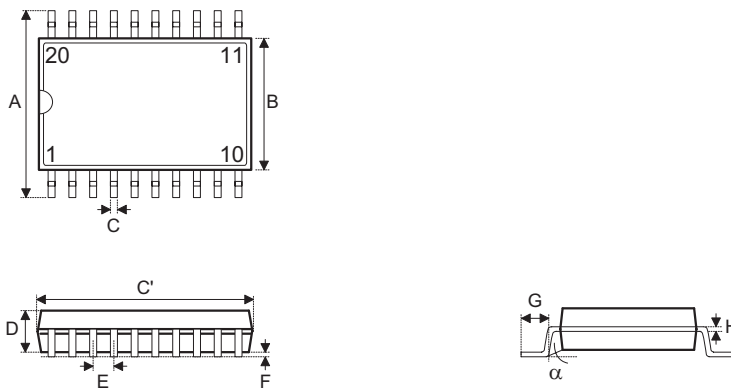

Symbol	Dimensions in mil		
	Min.	Nom.	Max.
A	394	—	419
B	290	—	300
C	14	—	20
C'	490	—	510
D	92	—	104
E	—	50	—
F	4	—	—
G	32	—	38
H	4	—	12
α	0°	—	10°

24-pin SOP (300mil) Outline Dimensions

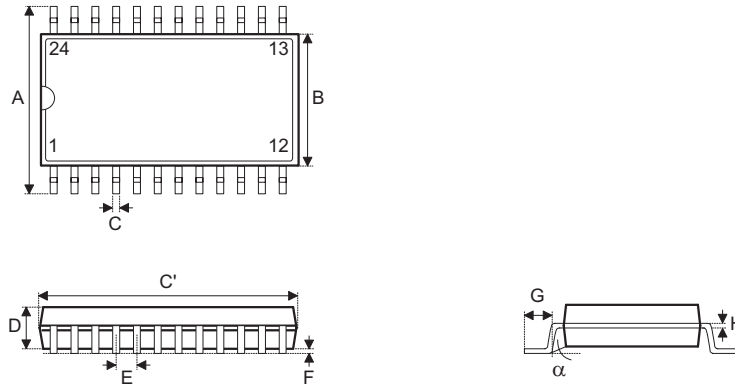

Symbol	Dimensions in mil		
	Min.	Nom.	Max.
A	394	—	419
B	290	—	300
C	14	—	20
C'	590	—	614
D	92	—	104
E	—	50	—
F	4	—	—
G	32	—	38
H	4	—	12
α	0°	—	10°

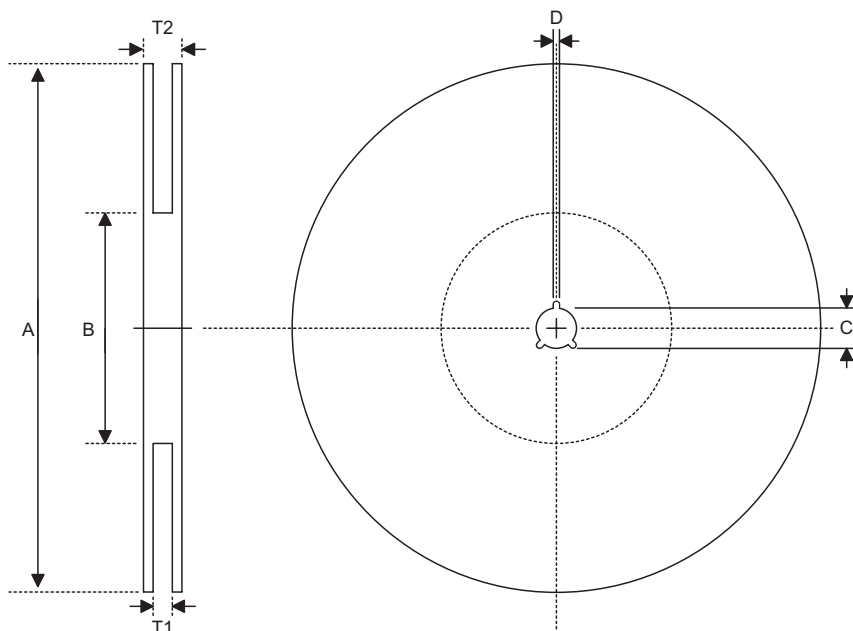
Product Tape and Reel Specifications
Reel Dimensions

SOP 20W

Symbol	Description	Dimensions in mm
A	Reel Outer Diameter	330±1.0
B	Reel Inner Diameter	62±1.5
C	Spindle Hole Diameter	13.0+0.5 -0.2
D	Key Slit Width	2.0±0.5
T1	Space Between Flange	24.8+0.3 -0.2
T2	Reel Thickness	30.2±0.2

SOP 24W

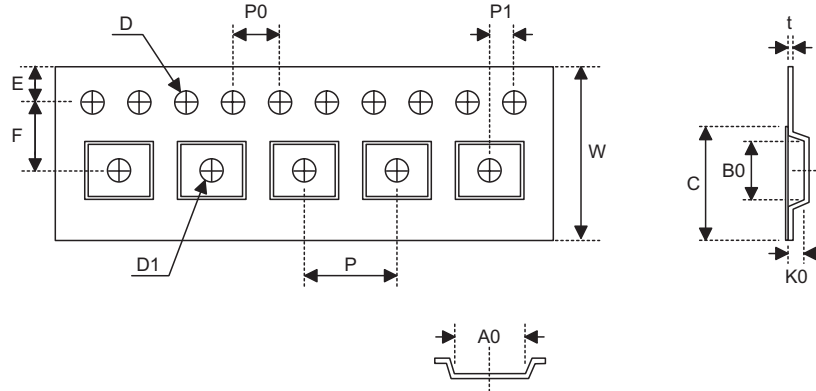
Symbol	Description	Dimensions in mm
A	Reel Outer Diameter	330±1.0
B	Reel Inner Diameter	62±1.5
C	Spindle Hole Diameter	13.0+0.5 -0.2
D	Key Slit Width	2.0±0.5
T1	Space Between Flange	24.8+0.3 -0.2
T2	Reel Thickness	30.2±0.2

Carrier Tape Dimensions

SOP 20W

Symbol	Description	Dimensions in mm
W	Carrier Tape Width	24.0+0.3 -0.1
P	Cavity Pitch	12.0±0.1
E	Perforation Position	1.75±0.1
F	Cavity to Perforation (Width Direction)	11.5±0.1
D	Perforation Diameter	1.5+0.1
D1	Cavity Hole Diameter	1.5+0.25
P0	Perforation Pitch	4.0±0.1
P1	Cavity to Perforation (Length Direction)	2.0±0.1
A0	Cavity Length	10.8±0.1
B0	Cavity Width	13.3±0.1
K0	Cavity Depth	3.2±0.1
t	Carrier Tape Thickness	0.3±0.05
C	Cover Tape Width	21.3

SOP 24W

Symbol	Description	Dimensions in mm
W	Carrier Tape Width	24.0±0.3
P	Cavity Pitch	12.0±0.1
E	Perforation Position	1.75±0.1
F	Cavity to Perforation (Width Direction)	11.5±0.1
D	Perforation Diameter	1.55+0.1
D1	Cavity Hole Diameter	1.5+0.25
P0	Perforation Pitch	4.0±0.1
P1	Cavity to Perforation (Length Direction)	2.0±0.1
A0	Cavity Length	10.9±0.1
B0	Cavity Width	15.9±0.1
K0	Cavity Depth	3.1±0.1
t	Carrier Tape Thickness	0.35±0.05
C	Cover Tape Width	21.3

Holtek Semiconductor Inc. (Headquarters)

No.3, Creation Rd. II, Science Park, Hsinchu, Taiwan
Tel: 886-3-563-1999
Fax: 886-3-563-1189
<http://www.holtek.com.tw>

Holtek Semiconductor Inc. (Taipei Sales Office)

4F-2, No. 3-2, YuanQu St., Nankang Software Park, Taipei 115, Taiwan
Tel: 886-2-2655-7070
Fax: 886-2-2655-7373
Fax: 886-2-2655-7383 (International sales hotline)

Holtek Semiconductor Inc. (Shanghai Sales Office)

7th Floor, Building 2, No.889, Yi Shan Rd., Shanghai, China 200233
Tel: 86-21-6485-5560
Fax: 86-21-6485-0313
<http://www.holtek.com.cn>

Holtek Semiconductor Inc. (Shenzhen Sales Office)

5/F, Unit A, Productivity Building, Cross of Science M 3rd Road and Gaoxin M 2nd Road, Science Park, Nanshan District, Shenzhen, China 518057
Tel: 86-755-8616-9908, 86-755-8616-9308
Fax: 86-755-8616-9722

Holtek Semiconductor Inc. (Beijing Sales Office)

Suite 1721, Jinyu Tower, A129 West Xuan Wu Men Street, Xicheng District, Beijing, China 100031
Tel: 86-10-6641-0030, 86-10-6641-7751, 86-10-6641-7752
Fax: 86-10-6641-0125

Holtek Semiconductor Inc. (Chengdu Sales Office)

709, Building 3, Champagne Plaza, No.97 Dongda Street, Chengdu, Sichuan, China 610016
Tel: 86-28-6653-6590
Fax: 86-28-6653-6591

Holtek Semiconductor (USA), Inc. (North America Sales Office)

46729 Fremont Blvd., Fremont, CA 94538
Tel: 1-510-252-9880
Fax: 1-510-252-9885
<http://www.holtek.com>

Copyright © 2007 by HOLTEK SEMICONDUCTOR INC.

The information appearing in this Data Sheet is believed to be accurate at the time of publication. However, Holtek assumes no responsibility arising from the use of the specifications described. The applications mentioned herein are used solely for the purpose of illustration and Holtek makes no warranty or representation that such applications will be suitable without further modification, nor recommends the use of its products for application that may present a risk to human life due to malfunction or otherwise. Holtek's products are not authorized for use as critical components in life support devices or systems. Holtek reserves the right to alter its products without prior notification. For the most up-to-date information, please visit our web site at <http://www.holtek.com.tw>.