



Holtek HT658/S Data Sheet

FEATURES

- Operating voltage: 2.4V~12V
- Low power and high noise immunity CMOS technology
- Low standby current
- Capable of decoding 18 bits of information
- Pairs with HOLTEK's HT640 encoder
- 10 address pins
- 8 data pins
- Trinary address setting
- Two times of receiving check
- Built-in oscillator needs only a 5% resistor
- Valid transmission indicator
- Easily interface with an RF or an infrared transmission medium
- Minimal external components



APPLICATIONS

- Burglar alarm system
- Smoke and fire alarm system
- Garage door controllers
- Car door controllers
- Car alarm system
- Security system
- Cordless telephones
- Other remote control systems

GENERAL DESCRIPTION

The HT658/S decoder is a CMOS LSI for remote control system applications. It is paired with the HT640/S encoder. The HT658 decoder receives serial address and data from the encoder that are transmitted by a carrier using an RF or an IR transmission medium. It then compares the serial input data twice continuously with its local address. If no errors or unmatched codes are encountered, the input data codes are decoded and then transferred to the output pins. The VT pin also goes high to indicate a valid transmission. The decoder is capable of decoding 18 bits of information that consists of 10 bits of address and 8 bits of data.

Note:

This product is manufactured and supported by Holtek Semiconductor. This data sheet is provided as a courtesy to Linx customers and is believed to be accurate at the time of publication, however these specifications may change at any time without notice. Linx Technologies makes no representation as to the accuracy or suitability of this information for any purpose. For more information please contact Holtek at www.holtek.com.

PIN OUT

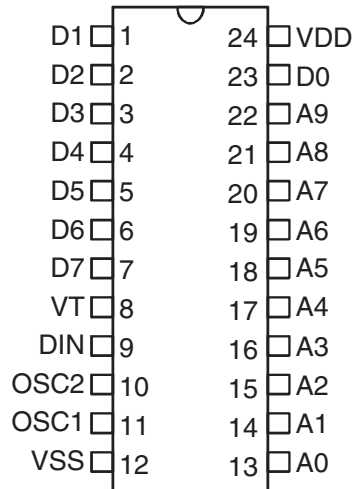

PIN DESCRIPTIONS

Pin Name	I/O	Internal Connection	Description
A0-A17	I	TRANSMISSION GATE	Input pins for address A0-A17 setting They can be externally set to VDD, VSS or left open.
D10-D17	O	CMOS OUT	Output data pins
DIN	I	CMOS IN	Serial data input pin
VT	O	CMOS OUT	Valid transmission, active high
OSC1	I	OSCILLATOR	Oscillator input pin
OSC2	O	OSCILLATOR	Oscillator output pin
VSS	I	—	Negative power supply (GND)
VDD	I	—	Positive power supply

APPROXIMATE INTERNAL CIRCUITS

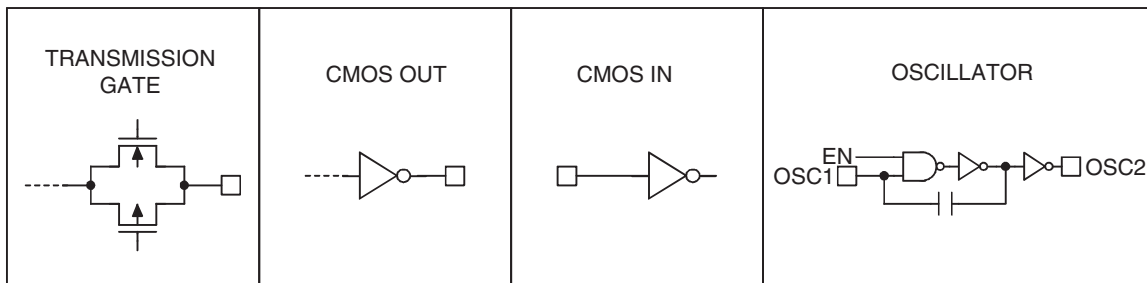

ABSOLUTE MAXIMUM RATINGS*

Supply Voltage -0.3V to 13V
 Input Voltage.....VSS-0.3V to VDD+0.3V

Storage Temperature..... -50°C to 125°C
 Operating Temperature..... -20°C to 75°C

*Note: Stresses above those listed under “Absolute Maximum Ratings” may cause permanent damage to the device. These are stress ratings only. Functional operation of this device at these or any other conditions above those indicated in the operational sections of this specification is not implied and exposure to absolute maximum rating conditions for extened periods may affect device reliability.

ELECTRICAL CHARACTERISTICS

Symbol	Parameter	Test Conditions		Min.	Typ.	Max.	Unit
		V _{DD}	Conditions				
V _{DD}	Operating Voltage	—	—	3	—	12	V
I _{STB}	Standby Current	5V	Oscillator Stops	—	0.1	1	μA
		12V		—	2	4	μA
I _{DD}	Operating Current	5V	No Load F _{OSC} = 100kHz	—	0.2	1	mA
I _O	Data Output Source Current (D10-D17)	5V	V _{OH} = 4.5V	-0.5	-1	—	mA
	Data Output Sink Current (D10-D17)		V _{OL} = 0.5V	0.5	1	—	mA
I _{VT}	VT Output Source Current	5V	V _{OH} = 4.5V	-2	-4	—	mA
	VT Output Sink Current		V _{OL} = 0.5V	1	2	—	mA
V _{IH}	"H" Input Voltage	5V	—	3.5	—	5	V
V _{IL}	"L" Input Voltage	5V	—	0	—	1	V
F _{OSC}	Oscillator Frequency	10V	R _{OSC} = 330kΩ	—	100	—	kHz

DECODER OSCILLATOR FREQUENCY VS SUPPLY VOLTAGE

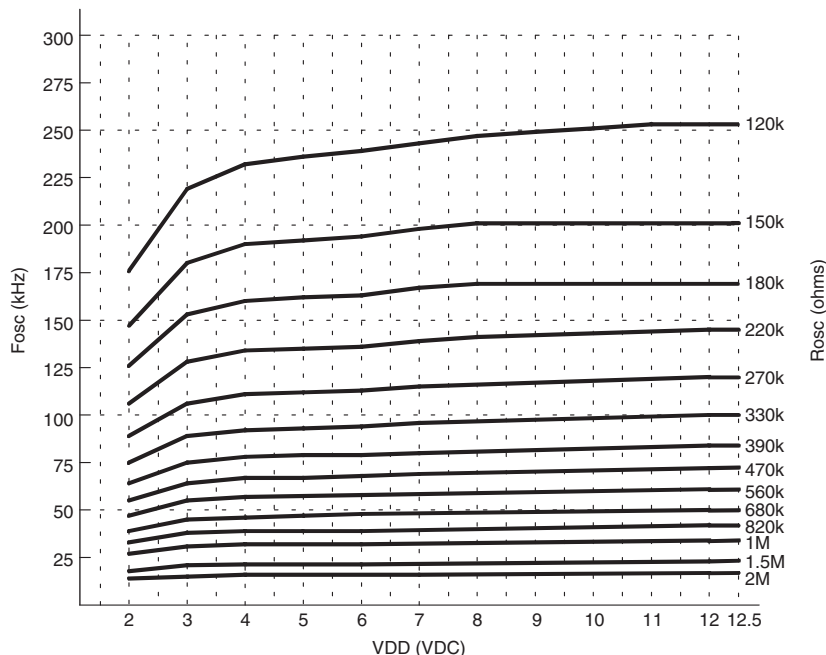

FUNCTIONAL DESCRIPTION

The HT658 decoder provides ten address and 8 data pins in a 24 pin SOP package. It is paired with the HT640 encoder. The decoders receive data transmitted by the encoders and interpret the first 10 bits of the code period as address and the last 8 bits as data. A signal on the DIN pin then activates the oscillator, which in turns decodes the incoming address and data. The decoders will check the received address twice continuously. If all the received address codes match the contents of the decoder's local address, the 8 bits of data are decoded to activate the output pins, and the VT pin is set high to indicate a valid transmission. That will last until the address code is incorrect or no signal has been received. The output of the VT pin is high only when the transmission is valid. Otherwise it is low always. The output type is momentary. The data outputs follow the encoder during a valid transmission and then reset.

Note: The oscillator is disabled in the standby state and activated as long as a logic "high" signal is applied to the DIN pin. i.e., the DIN should be kept "low" if there is no signal input.

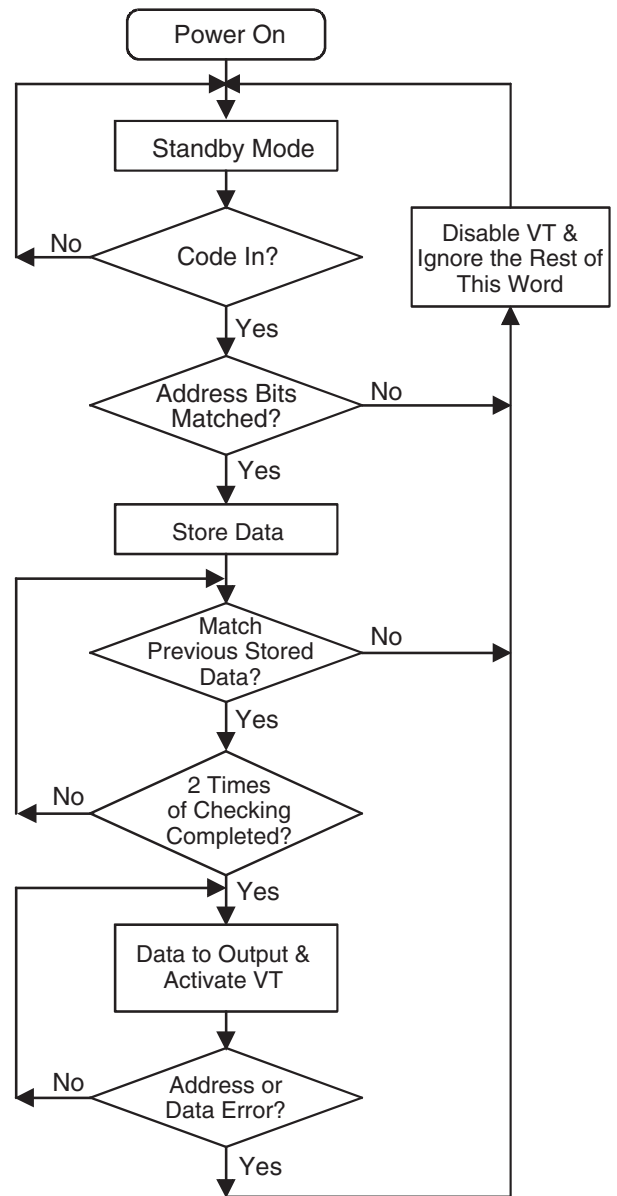

BLOCK DIAGRAM

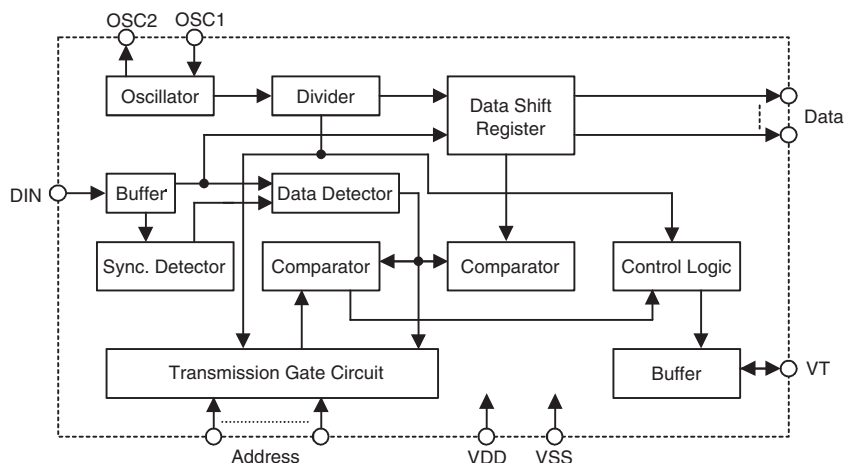

SOP-24 PACKAGE DIMENSIONS

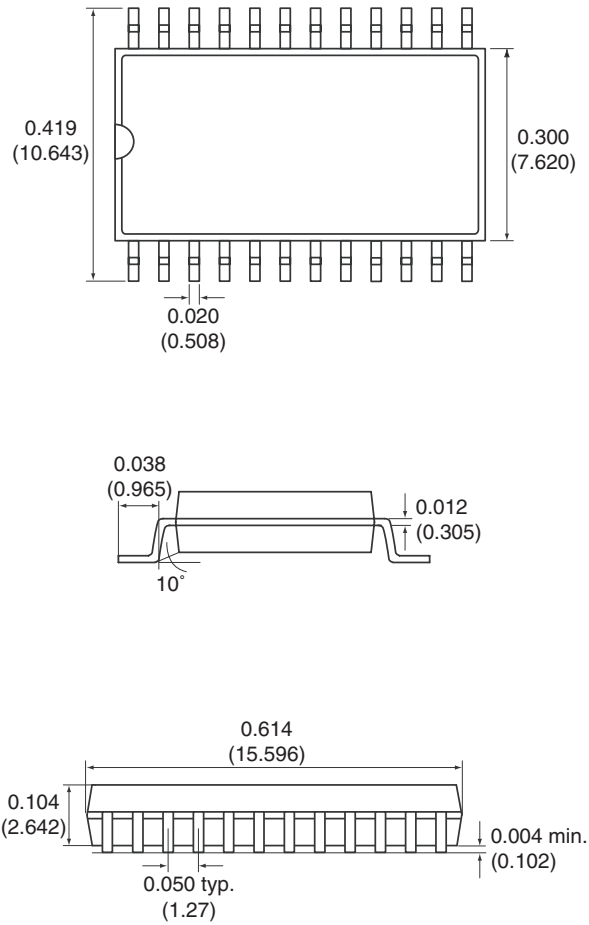

APPLICATION CIRCUIT

