



HT9201A/B

Simple Tone Dialer

Features

Patent Number: 113235(R.O.C.), 5424740(U.S.A.)

- Operating voltage: 2.0V~5.5V
- Low standby current
- 4x4 keyboard matrix
- 3.58MHz crystal or ceramic resonator
- Four flash key times selectable for the HT9201B

General Description

The HT9201A/B tone dialers are CMOS LSIs designed for telecommunication systems. The HT9201A is for mute output whereas the HT9201B is for flash output. Both dialers provide

good performance for regular DTMF dialing with low distortion output and minimal external components.

Selection Table

Function Item	MUTE	$\overline{\text{XMUTE}}$	F1,F2,F3,F4	A,B,C,D	Package
			Flash Time (ms)	DTMF Output	
HT9201A	√	√	—	√	16 DIP
HT9201B	—	√	600/300/200/90	—	16 DIP

Pin Assignment

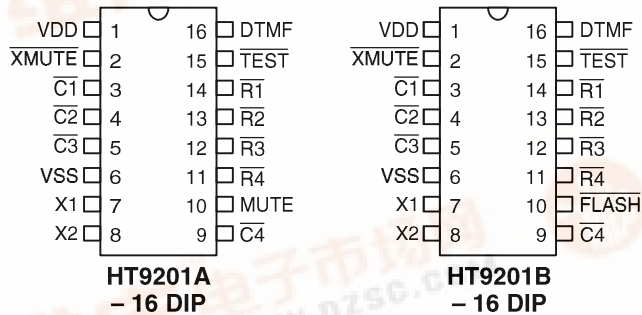

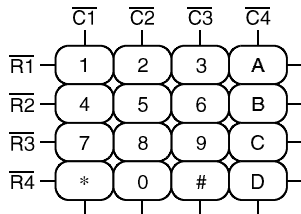
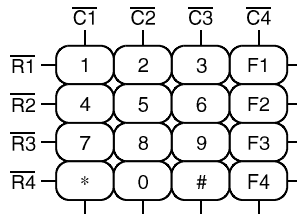
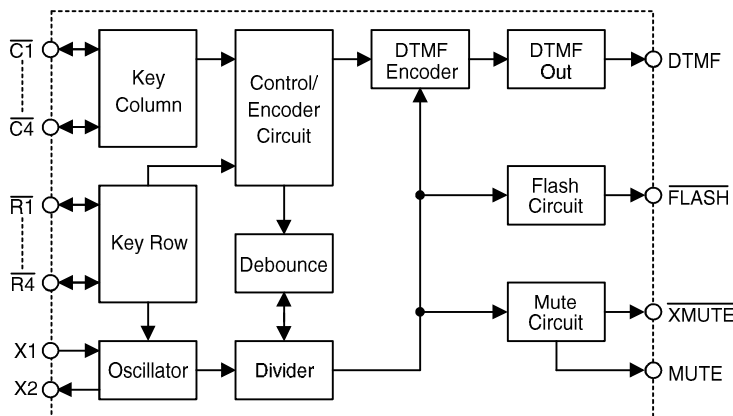
Keyboard Information
HT9201A

HT9201B

Block Diagram

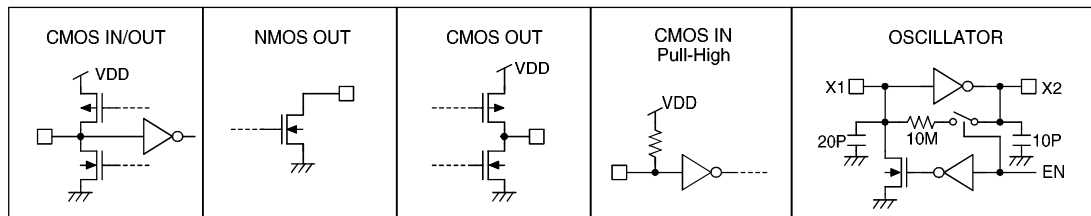
Pin Description

Pin Name	I/O	Internal Connection	Description
$\overline{C1} \sim \overline{C4}$ $\overline{R1} \sim \overline{R4}$	I/O	CMOS IN/OUT	<p>These pins form a 4×4 keyboard matrix which can perform keyboard input detection and dialing specification setting functions. When the chip is in the standby mode the column group ($\overline{C1} \sim \overline{C4}$) remains high whereas the row group ($\overline{R1} \sim \overline{R4}$) is set high for key input detection.</p> <p>An inexpensive single contact 4×4 keyboard can be used as an input device. Pressing a key connects a single column to a single row, and actuates the system oscillator which result in a dialing signal output. If more than two keys are pressed at a time, no response occurs. The key-in debounce time is 20ms. Refer to the keyboard information for keyboard arrangement.</p>

Pin Name	I/O	Internal Connection	Description
X1	I	OSCILLATOR	The system oscillator consists of an inverter, a bias resistor and the necessary load capacitor on chip. Connecting a standard 3.579545MHz crystal or ceramic resonator to the X1 and X2 terminals can implement the oscillator function. The oscillator is turned off in the standby mode, and is actuated whenever a keyboard entry is detected.
X2	O		
$\overline{\text{XMUTE}}$	O	NMOS OUT	$\overline{\text{XMUTE}}$ is an NMOS open drain structure pulled to VSS during dialing signal transmission. Otherwise, it is an open circuit. XMUTE is used to mute the speech circuit when transmitting the dial signal.
MUTE	O	CMOS OUT	The output is low when no keypad input is entered and it becomes high during dialing sequence. The timing diagram is shown in the operation timing.
$\overline{\text{FLASH}}$	O	CMOS OUT	This pin is a CMOS output structure from which the chip receives the flash key (F1~F4) signals to break the telephone line for a flash time.
$\overline{\text{TEST}}$	I	CMOS IN Pull-High	For IC chip test only
VDD	I	—	Positive power supply, 2.0V~5.5V for normal operation
VSS	I	—	Negative power supply

Approximate internal connection circuits

Absolute Maximum Ratings*

Supply Voltage	-0.3V to 6V	Storage Temperature	-50°C to 125°C
Input Voltage	V _{SS} -0.3V to V _{DD} +0.3V	Operating Temperature	-20°C to 75°C

*Note: Stresses above those listed under “Absolute Maximum Ratings” may cause permanent damage to the device. These are stress ratings only. Functional operation of this device at these or any other conditions above those indicated in the operational sections of this specification is not implied and exposure to absolute maximum rating conditions for extended periods may affect device reliability.

Electrical Characteristics

(Ta=25°C)

Symbol	Parameter	Test Conditions		Min.	Typ.	Max.	Unit
		V _{DD}	Conditions				
V _{DD}	Operating Voltage	—		2	—	5.5	V
I _{DD}	Operating Current	2.5V	Keypad entry No load	—	0.6	2	mA
I _{STB}	Standby Current	2.5V	No load, no entry	—	—	1	μA
V _{IL}	Input Low Voltage	—	—	V _{SS}	—	0.2V _{DD}	V
V _{IH}	Input High Voltage	—	—	0.8V _{DD}	—	V _{DD}	V
I _{XMO}	$\overline{\text{XMUTE}}$ Leakage Current	—	V $\overline{\text{XMUTE}}$ =12V No entry	—	—	1	μA
I _{O_{LXM}}	$\overline{\text{XMUTE}}$ Sink Current	2.5V	V $\overline{\text{XMUTE}}$ =0.5V	1	—	—	mA
I _{O_{H1}}	Keypad Pin Source Current	2.5V	V _{OH} =0V	-4	—	-40	μA
I _{O_{L1}}	Keypad Pin Sink Current	2.5V	V _{OL} =2.5V	200	400	—	μA
T _{DB}	Key-in Debounce Time	—	F _{OSC} =3.5795MHz	—	20	—	ms
F _{OSC}	System Frequency	—	Crystal=3.5795MHz	3.5759	3.5795	3.5831	MHz

Tone Mode Electrical Characteristics

 (F_{OSC}=3.5795MHz, Ta=25°C)

Symbol	Parameter	Test Conditions		Min.	Typ.	Max.	Unit
		V _{DD}	Conditions				
V _{TDC}	DTMF Output DC Level	—	—	0.45V _{DD}	—	0.7V _{DD}	V
I _{TOL}	DTMF Sink Current	2.5V	V _{DTMF} =0.5V	0.1	—	—	mA
V _{TAC}	DTMF Output AC Level	—	Row group, R _L =5kΩ	0.12	0.155	0.18	V _{rms}
R _L	DTMF Output Load	2.5V	THD≤-23dB	5	—	—	kΩ
ACR	Column Pre-emphasis	2.5V	Row group=0dB	1	2	3	dB
THD	DTMF Signal Distortion	2.5V	R _L =5kΩ	—	-30	-23	dB

$$\text{THD (Distortion) (dB)} = 20 \log \left(\frac{\sqrt{V_1^2 + V_2^2 + \dots + V_n^2}}{\sqrt{V_i^2 + V_h^2}} \right)$$

 V_i, V_h: Row group and column group signals

 V₁, V₂, ... V_n: Harmonic signals (BW=300Hz~3500Hz)

Functional Description

Keyboard matrix

$\overline{C1}$ – $\overline{C4}$ and $\overline{R1}$ – $\overline{R4}$ form a keyboard matrix. The keyboard arrangement for each of the HT9201 series are shown in the **Keyboard Information**.

Tone frequency

Tone Name	Output Frequency (Hz)		% Error
	Specified	Actual	
$\overline{R1}$	697	699	+0.29%
$\overline{R2}$	770	766	-0.52%
$\overline{R3}$	852	847	-0.59%
$\overline{R4}$	941	948	+0.74%
$\overline{C1}$	1209	1215	+0.50%
$\overline{C2}$	1336	1332	-0.30%
$\overline{C3}$	1477	1472	-0.34%
$\overline{C4}$	1633	1645	+0.73%

Note: % Error does not contain the crystal frequency drift

Key definition

- 0, 1, 2, 3, 4, 5, 6, 7, 8, 9, *, #, A, B, C, D keys
These are the dialing number input keys for normal operation.

- F1, F2, F3, F4

The flash keys can be selected with different flash times as shown in the following table.

Flash time selection table

Key	Flash Time (ms)
F1	600
F2	300
F3	200
F4	90

Keyboard operation

(a) without flash key

Keyboard input: $\overline{D1}$ $\overline{D2}$... \overline{Dn}

Dialing output: D1 D2 ... Dn

(b) with flash key (F1/F2/F3/F4)

Keyboard input: $\overline{D1}$ $\overline{D2}$... \overline{Dn} \overline{F} $\overline{Dn+1}$... \overline{Dm}

(Note: F=F1/F2/F3/F4)

Dialing output: D1 D2 ... Dn T_F (break a flash time)
Dn+1 ... Dm

Timing Diagrams

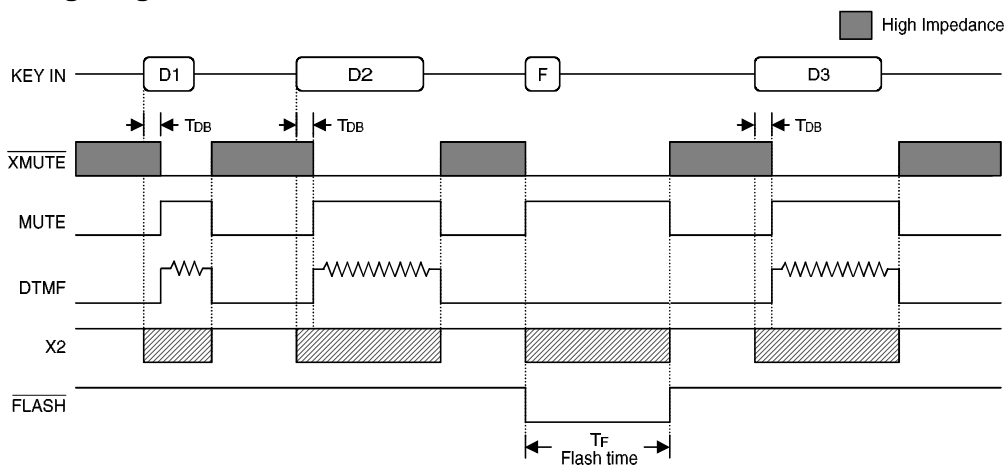

Application Circuits

Application circuit 1

