

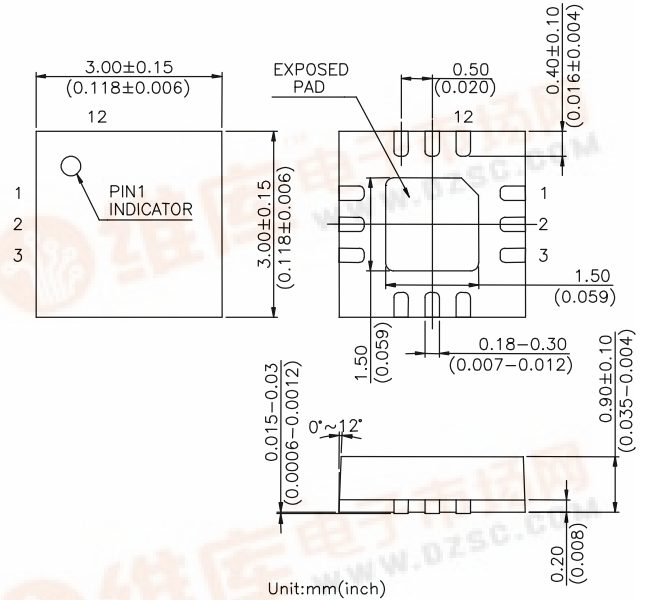

Features

- **Low Insertion Loss** : 0.75 dB @ 2.50 GHz
1.25 dB @ 5.85 GHz
- **Isolation**: 25.5 dB @ 2.50 GHz
14.5 dB @ 5.85 GHz
- **Low DC Power Consumption**
- **Miniature QFN12L (3x3 mm) Plastic Lead (Pb) Free Package, RoHS Compliant**
- **PHEMT process**

QFN12L (3 x 3 mm)



Description

The HWS453 is a GaAs PHEMT MMIC DPDT switch operating at DC-6 GHz in a low cost miniature QFN12L (3 x 3 mm) plastic lead (Pb) free package. The HWS453 features low insertion loss and high isolation with very low DC power consumption. This switch can be used in IEEE 802.11a/b/g WLAN systems for combination of transmit/receive and antenna diversity functions.

Electrical Specifications at 25 °C with 0, +3V Control Voltages

Parameter	Test Conditions	Min.	Typ.	Max.	Unit
Insertion Loss	0.10-6.00 GHz		1.25		dB
	2.40-2.50 GHz		0.75	1.00	dB
	5.15-5.85 GHz		1.25		dB
Isolation (on-off or off-on)	0.10-6.00 GHz	20.0	14.0		dB
	2.40-2.50 GHz		25.5		dB
	5.15-5.85 GHz		14.5		dB
Return Loss	0.10-6.00 GHz		15		dB
	2.40-2.50 GHz		20		dB
	5.15-5.85 GHz		15		dB
Input Power for One dB Compression	2.00-6.00 GHz		34		dBm
Input Third Order Intermodulation Intercept Point	20 dBm Per Tone @ 2.50 GHz		52		dBm
	22 dBm Per Tone @ 5.85 GHz		52		dBm
Control Current			5	200	uA

Note: All measurements made in a 50 ohm system with 0/+3.0V control voltages, unless otherwise specified.

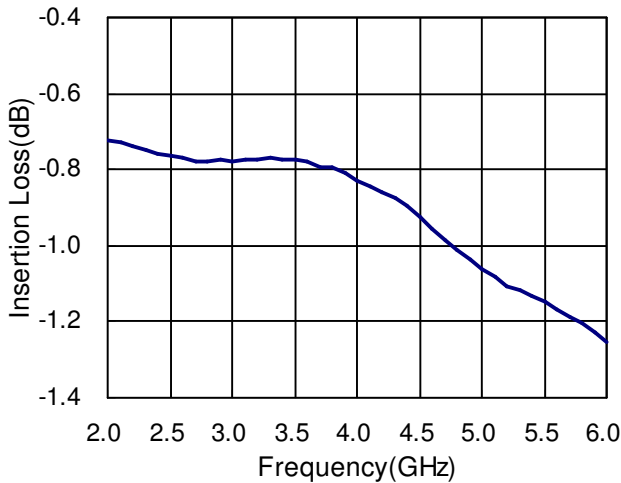
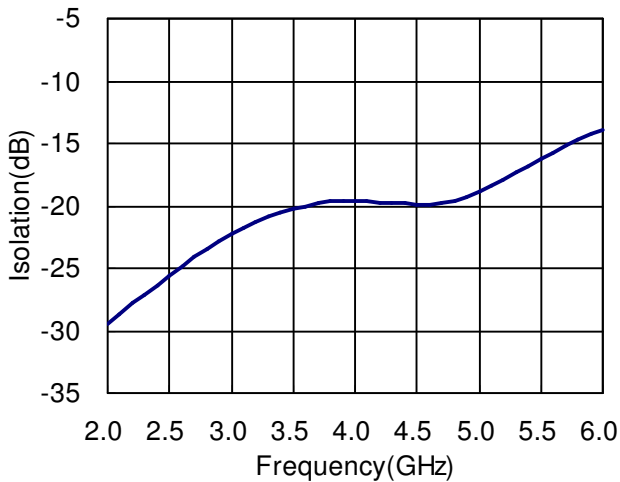
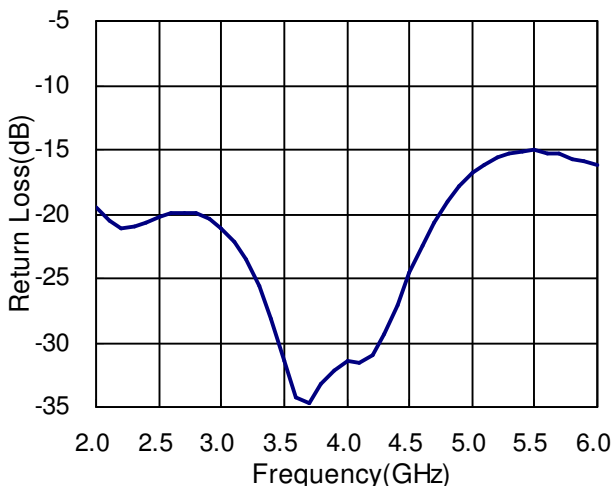

Typical Performance Data with 8pF Capacitors @ +25 °C
Insertion Loss vs Frequency

Isolation vs Frequency

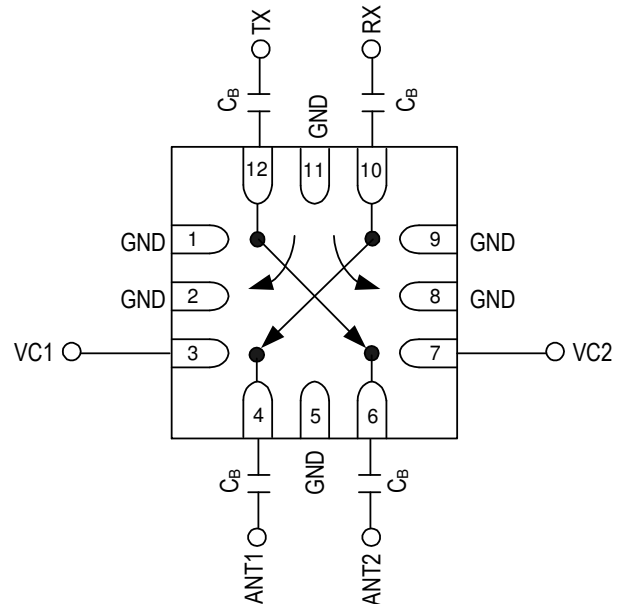
Return Loss vs Frequency

Absolute Maximum Ratings

Parameter	Absolute Maximum
RF Input Power	+34 dBm @ +3V
Control Voltage	+6V
Operating Temperature	-40 °C to +85 °C
Storage Temperature	-65 °C to +150 °C

Pin Out (Top View)

Note:

- DC blocking capacitors $C_B=8\text{pF}$ are required on all RF ports.
- Exposed pad in the bottom must be connected to ground by via holes.
- TX and RX ports can be used interchangeably.

Logic Table for Switch On-Path

VC1	VC2	ANT1-RX	ANT1-TX	ANT2-TX	ANT2-RX
1	0	On	Off	On	Off
0	1	Off	On	Off	On
1	1	Off	Off	Off	Off
0	0	Off	Off	Off	Off

'1' = +3V to +5V
'0' = 0V to +0.2V