



## Description

The ICS525-07/08 are the most flexible way to generate a high-quality clock output from an inexpensive crystal or clock input at low supply voltages. The user can configure the device to produce nearly any output frequency from any input frequency by grounding or floating the select pins or by driving or hard wiring the select pins high or low. Neither microcontroller, software, nor device programmer are needed to set the frequency. Using Phase-Locked Loop (PLL) techniques, the device accepts a standard fundamental mode, inexpensive crystal to produce output clocks up to 250 MHz. It can also produce a highly accurate output clock from a given input clock, keeping them frequency locked.

For similar capability with a serial interface, use the ICS307.

This product is intended for clock generation. It has low output jitter (variation in the output period), but input to output skew is not defined nor guaranteed.

## Features

- Packaged as 28-pin SSOP (150 mil body)
- Available in Pb (lead) free package
- User determines the output frequency by setting all internal dividers
- Eliminates need for custom oscillators
- Low voltage operation
- Pull-ups on all select inputs
- Input crystal frequency of 5 - 27 MHz
- Input clock frequency of 2 - 50 MHz
- Compensated loop bandwidth
- Enhanced low frequency operation (-08 version)
- Low jitter
- Duty cycle of 45/55 up to 200 MHz
- Operating voltage of 1.8 V to 2.5 V
- Ideal for oscillator replacement
- Available in commercial and industrial temperature ranges

## Block Diagram

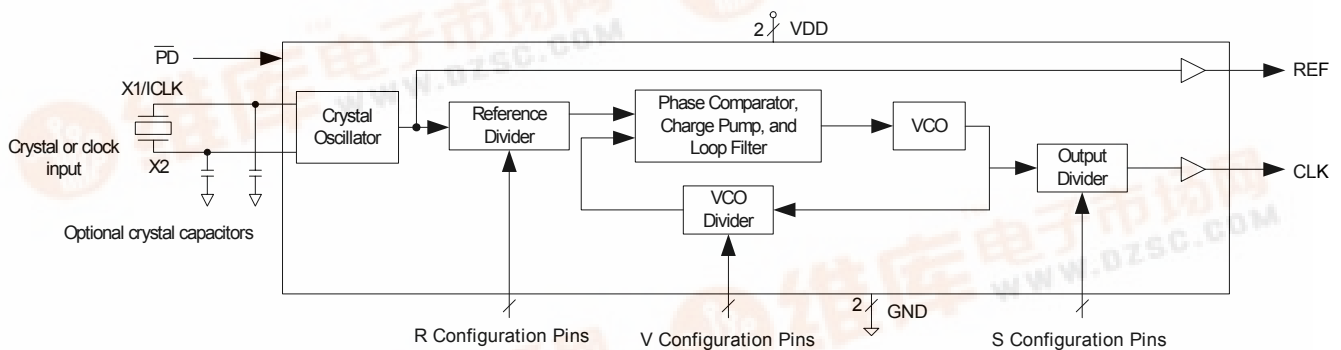

**Pin Assignment (ICS525-07)**

R5	<input type="checkbox"/>	1	28	<input type="checkbox"/>	R4
R6	<input type="checkbox"/>	2	27	<input type="checkbox"/>	R3
S0	<input type="checkbox"/>	3	26	<input type="checkbox"/>	R2
S1	<input type="checkbox"/>	4	25	<input type="checkbox"/>	R1
S2	<input type="checkbox"/>	5	24	<input type="checkbox"/>	R0
VDD	<input type="checkbox"/>	6	23	<input type="checkbox"/>	VDD
X1/CLK	<input type="checkbox"/>	7	22	<input type="checkbox"/>	REF
X2	<input type="checkbox"/>	8	21	<input type="checkbox"/>	CLK
GND	<input type="checkbox"/>	9	20	<input type="checkbox"/>	GND
V0	<input type="checkbox"/>	10	19	<input type="checkbox"/>	$\overline{\text{PD}}$
V1	<input type="checkbox"/>	11	18	<input type="checkbox"/>	V8
V2	<input type="checkbox"/>	12	17	<input type="checkbox"/>	V7
V3	<input type="checkbox"/>	13	16	<input type="checkbox"/>	V6
V4	<input type="checkbox"/>	14	15	<input type="checkbox"/>	V5

**Pin Descriptions (ICS525-07)**

Pin Number	Pin Name	Pin Type	Pin Description
1, 2, 24-28	R5, R6, R0-R4	I(PU)	Reference divider word input pins.
3, 4, 5	S0, S1, S2	I(PU)	Select pins for output divider. See table on page 4.
6, 23	VDD	Power	Connect to VDD.
7	X1/CLK	X1	Crystal connection. Connect to a parallel resonant fundamental crystal or input clock.
8	X2	X2	Crystal connection. Connect to a crystal or leave unconnected for clock.
9, 20	GND	Power	Connect to ground.
10 - 18	V0 - V8	I(PU)	VCO divider word input pins.
19	$\overline{\text{PD}}$	Input	Power-down. Active low. Turns off entire chip when low. Clock outputs stop low.
21	CLK	Output	PLL output clock.
22	REF	Output	Reference output. Buffered crystal oscillator (or clock) output.

KEY: I(PU) = Input with internal pull-up resistor; X1, X2 = crystal connections

**Pin Assignment (ICS525-08)**

R5	<input type="checkbox"/>	1	28	<input type="checkbox"/>	R4
S3	<input type="checkbox"/>	2	27	<input type="checkbox"/>	R3
S0	<input type="checkbox"/>	3	26	<input type="checkbox"/>	R2
S1	<input type="checkbox"/>	4	25	<input type="checkbox"/>	R1
S2	<input type="checkbox"/>	5	24	<input type="checkbox"/>	R0
VDD	<input type="checkbox"/>	6	23	<input type="checkbox"/>	VDD
X1/ICLK	<input type="checkbox"/>	7	22	<input type="checkbox"/>	REF
X2	<input type="checkbox"/>	8	21	<input type="checkbox"/>	CLK
GND	<input type="checkbox"/>	9	20	<input type="checkbox"/>	GND
V0	<input type="checkbox"/>	10	19	<input type="checkbox"/>	$\overline{\text{PD}}$
V1	<input type="checkbox"/>	11	18	<input type="checkbox"/>	V8
V2	<input type="checkbox"/>	12	17	<input type="checkbox"/>	V7
V3	<input type="checkbox"/>	13	16	<input type="checkbox"/>	V6
V4	<input type="checkbox"/>	14	15	<input type="checkbox"/>	V5

**Pin Descriptions (ICS525-08)**

Pin Number	Pin Name	Pin Type	Pin Description
1, 24-28	R5, R0-R4	I(PU)	Reference divider word input pins.
2, 3, 4, 5	S0, S1, S2, S3	I(PU)	Select pins for output divider. See table on page 4.
6, 23	VDD	Power	Connect to VDD.
7	X1/ICLK	X1	Crystal connection. Connect to a parallel resonant fundamental crystal or input clock.
8	X2	X2	Crystal connection. Connect to a crystal or leave unconnected for clock.
9, 20	GND	Power	Connect to ground.
10 - 18	V0 - V8	I(PU)	VCO divider word input pins.
19	$\overline{\text{PD}}$	Input	Power-down. Active low. Turns off entire chip when low. Clock outputs stop low.
21	CLK	Output	PLL output clock.
22	REF	Output	Reference output. Buffered crystal oscillator (or clock) output.

**Output Frequency and Output Divider Table (ICS525-07)**

S2 Pin 5	S1 Pin 4	S0 Pin 3	CLK Output Divider	Output Frequency Range (MHz)			
				VDD = 2.5 V		VDD = 1.8 V	
				Min	Max	Min	Max
0	0	0	12	8.3	20.8	8.3	20.8
0	0	1	2	50	125	50	125
0	1	0	16	6.25	15.63	6.25	15.63
0	1	1	4	25	62.5	25	62.5
1	0	0	5	20	50	20	50
1	0	1	7	14.3	35.7	14.3	35.7
1	1	0	1	100	250	100	250
1	1	1	3	33.3	83.33	33.3	83.33

**Output Frequency and Output Divider Table (ICS525-08)**

S3 Pin 2	S2 Pin 5	S1 Pin 4	S0 Pin 3	CLK Output Divider	Output Frequency Range (MHz)			
					VDD = 2.5 V		VDD = 1.8 V	
					Min	Max	Min	Max
0	0	0	0	2	23.9	200	23.9	200
0	0	0	1	3	15.9	200	15.9	200
0	0	1	0	4	11.9	200	11.9	200
0	0	1	1	5	9.5	158.4	9.5	158.4
0	1	0	0	7	6.8	113.1	6.8	113.1
0	1	0	1	8	6.0	99.0	6.0	99.0
0	1	1	0	9	5.3	88.0	5.3	88.0
0	1	1	1	10	4.8	79.2	4.8	79.2
1	0	0	0	11	4.3	72.0	4.3	72.0
1	0	0	1	13	3.7	60.9	3.7	60.9
1	0	1	0	14	3.4	56.6	3.4	56.6
1	0	1	1	15	3.2	52.8	3.2	52.8
1	1	0	0	17	2.8	46.6	2.8	46.6
1	1	0	1	19	2.5	41.7	2.5	41.7
1	1	1	0	48	1.0	16.5	1.0	16.5
1	1	1	1	128	0.4	6.2	0.4	6.2



## External Components/Crystal Selection

### Decoupling Capacitors

The ICS525-07/08 require two 0.01µF decoupling capacitors to be connected between VDD and GND, one on each side of the chip. The capacitor must be connected close to the device to minimize lead inductance.

### Crystal Load Capacitors

The approximate total on-chip capacitance for a crystal is 16 pF, so a parallel resonant, fundamental mode crystal with this value of load (correlation) capacitance should be used. For crystals with a specified load capacitance greater than 16 pF, crystal capacitors may be connected from each of the pins X1 and X2 to Ground as shown in the block diagram. The value (in pF) of these crystal caps should be  $(CL - 16)^2$ , where CL is the crystal load capacitance in pF. These external capacitors are only required for applications where the exact frequency is critical. For a clock input, connect to X1 and leave X2 unconnected (no capacitors on either).

### Configuring the Frequency

The ICS525-07/08 output frequency is determined by its internal dividers according to this equation:

$$f_{OUT} = \frac{V * f_{IN}}{R * OD}$$

**V** is the feedback divider and can be 8, 9, 10, 12...519 (not 11).

For the ICS525-07, **R** is the reference divider and can be 2, 3, 4...129.

For the ICS525-08, **R** can be 1, 2...64.

For the ICS525-07, **OD** can be 1, 2, 3, 4, 5, 7, 12, or 16.

For the ICS525-08, **OD** can be 2, 3, 4, 5, 7, 8, 9, 10, 11, 13, 14, 15, 17, 19, 48, or 128.

The VCO must be kept in its operating range according to this equation:

$$50MHz < \frac{V * f_{IN}}{R} < 400MHz$$

The phase detector must be kept in its operating range according to this equation:

$$250kHz < \frac{f_{IN}}{R}$$

Optimum values for **V**, **R**, and **OD** are found iteratively by applying the above equations. Choosing a smaller value of **R** will give better jitter. A calculator program is available on the ICS website to automate the process.

After determining **V**, **R**, and **OD**, convert them to the pin address.

V8...0 = binary(V - 8)

Example: V = 17, V8...0 = 00001001

For the ICS525-07, R6...0 = binary(R - 2)

Example: R = 15, R6...0 = 0001101

For the ICS525-08, R5...0 = binary(R - 2)

Example: R = 15, R5...0 = 001101

S2...0 or S3...0 is configured according to the tables on page 4.

All of the configuration pins have on-chip pull-up resistors, so pins can be floated to generate a "1", or tied to ground for a "0". They can also be driven directly by logic signals.

### Output Termination

The output driver impedance is approximately 17 ohms. Use a 33 ohm series termination resistor on each output to match a 50 ohm trace.

### Reference Source

The initial accuracy and temperature stability of the output frequency is determined by the reference frequency source, the crystal, or the input clock. The PLL will track the input frequency, so if the crystal is running at +5 ppm the CLK frequency will also be +5 ppm. A low amplitude sinusoidal reference (such as the 1 V p-p signal from a TCXO) can be used by the AC coupling it to the X1 pin with a 0.1 µF capacitor. The X1 pin is self-biasing.



## Absolute Maximum Ratings

Stresses above the ratings listed below can cause permanent damage to the ICS525-07/08. These ratings, which are standard values for ICS commercially rated parts, are stress ratings only. Functional operation of the device at these or any other conditions above those indicated in the operational sections of the specifications is not implied. Exposure to absolute maximum rating conditions for extended periods can affect product reliability. Electrical parameters are guaranteed only over the recommended operating temperature range.

Item	Rating
Supply Voltage, VDD	5 V
All Inputs and Outputs	-0.5 V to VDD+0.5 V
Ambient Operating Temperature, Commercial	0 to +70°C
Ambient Operating Temperature, Industrial	-40 to +85°C
Storage Temperature	-65°C to 150°C
Junction Temperature	125°C
Soldering Temperature	260°C (max. of 10 seconds)

## DC Electrical Characteristics

Unless stated otherwise, VDD = 1.8 V to 2.5 V

Parameter	Symbol	Conditions	Min.	Typ.	Max.	Units
Operating Voltage	VDD		1.6		2.25	V
Operating Supply Current, 15 MHz crystal	IDD	60 MHz out, no load		TBD		mA
Operating Supply Current, Power-down	IDD	Pin 19 = 0		TBD		mA
Input High Voltage	V <sub>IH</sub>		0.65VDD			V
Input Low Voltage	V <sub>IL</sub>				0.35VDD	V
Output High Voltage	V <sub>OH</sub>	I <sub>OH</sub> = -8 mA	0.75VDD			V
Output Low Voltage	V <sub>OL</sub>	I <sub>OL</sub> = 8 mA			0.25VDD	V
Short Circuit Current		CLK and REF outputs		±55		mA
Input Capacitance	C <sub>IN</sub>	V, R, S pins and pin 19		4		pF
On-chip Pull-up Resistor	R <sub>PU</sub>	V, R, S pins and pin 19		270		kΩ



## AC Electrical Characteristics

Unless stated otherwise, **VDD = 1.8 V to 2.5 V**

Parameter	Symbol	Conditions	Min.	Typ.	Max.	Units
Input Frequency	$F_{IN}$	Crystal input	5		27	MHz
		Clock input	2		50	MHz
Output Frequency (ICS525-07)	$F_{OUT}$	-40 to +85°C	10		200	MHz
Output Frequency (ICS525-08)	$F_{OUT}$	-40 to +85°C	0.4		200	MHz
Output Clock Rise Time		20% to 80%		1		ns
Output Clock Fall Time		80% to 20%		1		ns
Output Clock Duty Cycle		at VDD/2	45	49 to 51	55	%
Power-down Time, PD low to clocks stopped					50	ns
Power-up Time, PD high to clocks stable					5	ms
Absolute Clock Period Jitter, VDD = 2.5 V	$t_{ja}$	Deviation from mean				ps
One Sigma Clock Period Jitter, VDD = 2.5 V	$t_{js}$	One Sigma				ps
Absolute Clock Period Jitter, VDD = 1.8 V	$t_{ja}$	Deviation from mean				ps
One Sigma Clock Period Jitter, VDD = 1.8 V	$t_{js}$	One Sigma				ps

NOTE 1: Phase relationship between input and output can change at power-up.



### Package Outline and Package Dimensions (28-pin SSOP, 150 mil Body)

Package dimensions are kept current with JEDEC Publication No. 95, MO-153

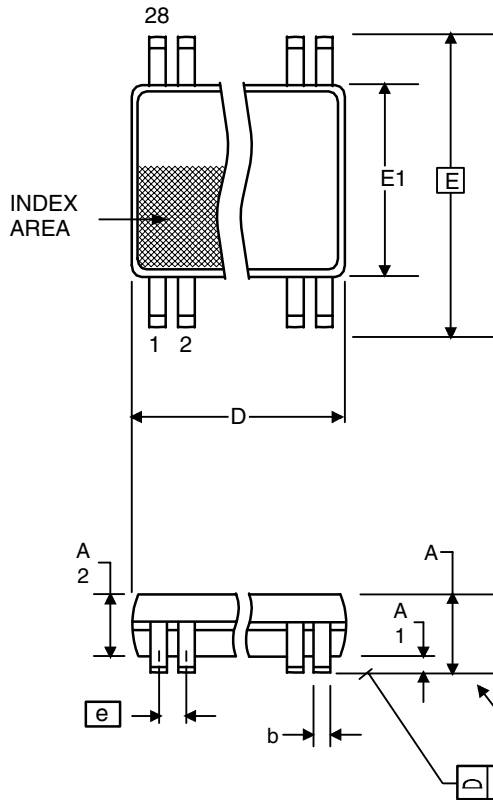

Symbol	Millimeters		Inches	
	Min	Max	Min	Max
A	1.35	1.75	.053	.069
A1	0.10	0.25	.0040	.010
A2	--	1.50	--	.059
b	0.20	0.30	.008	.012
C	0.18	0.25	.007	.010
D	9.80	10.00	.386	.394
E	5.80	6.20	.228	.244
E1	3.80	4.00	.150	.157
e	0.635 Basic		0.025 Basic	
L	0.40	1.27	.016	.050
$\alpha$	0°	8°	0°	8°
aaa	--	0.10	--	0.004

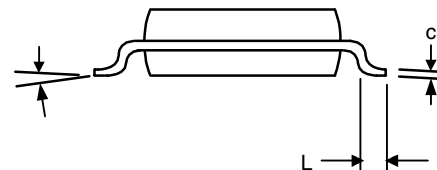





## Ordering Information

Part / Order Number	Marking	Shipping Packaging	Package	Temperature
ICS525R-07	ICS525R-07	Tubes	28-pin SSOP	0 to +70°C
ICS525R-07T	ICS525R-07	Tape and Reel	28-pin SSOP	0 to +70°C
ICS525R-07LF	ICS525R-07LF	Tubes	28-pin SSOP	0 to +70°C
ICS525R-07LFT	ICS525R-07LF	Tape and Reel	28-pin SSOP	0 to +70°C
ICS525RI-07	ICS525R-I07	Tubes	28-pin SSOP	-40 to +85°C
ICS525RI-07T	ICS525RI-07	Tape and Reel	28-pin SSOP	-40 to +85°C
ICS525RI-07LF	ICS525RI07LF	Tubes	28-pin SSOP	-40 to +85°C
ICS525RI-07LFT	ICS525RI07LF	Tape and Reel	28-pin SSOP	-40 to +85°C
ICS525R-08	ICS525R-08	Tubes	28-pin SSOP	0 to +70°C
ICS525R-08T	ICS525R-08	Tape and Reel	28-pin SSOP	0 to +70°C
ICS525R-08LF	ICS525R-08LF	Tubes	28-pin SSOP	0 to +70°C
ICS525R-08LFT	ICS525R-08LF	Tape and Reel	28-pin SSOP	0 to +70°C
ICS525RI-08	ICS525RI-08	Tubes	28-pin SSOP	-40 to +85°C
ICS525RI-08T	ICS525RI-08	Tape and Reel	28-pin SSOP	-40 to +85°C
ICS525RI-08LF	ICS525RI08LF	Tubes	28-pin SSOP	-40 to +85°C
ICS525RI-08LFT	ICS525RI08LF	Tape and Reel	28-pin SSOP	-40 to +85°C

**Parts that are ordered with a “LF” suffix to the part number are the Pb-Free configuration and are RoHS compliant.**

While the information presented herein has been checked for both accuracy and reliability, Integrated Circuit Systems (ICS) assumes no responsibility for either its use or for the infringement of any patents or other rights of third parties, which would result from its use. No other circuits, patents, or licenses are implied. This product is intended for use in normal commercial applications. Any other applications such as those requiring extended temperature range, high reliability, or other extraordinary environmental requirements are not recommended without additional processing by ICS. ICS reserves the right to change any circuitry or specifications without notice. ICS does not authorize or warrant any ICS product for use in life support devices or critical medical instruments.