

MicroPOWER INSTRUMENTATION AMPLIFIER

Single and Dual Versions

FEATURES

- **LOW QUIESCENT CURRENT:** 175µA/chan.
- **WIDE SUPPLY RANGE:** ±1.35V to ±18V
- **LOW OFFSET VOLTAGE:** 250µV max
- **LOW OFFSET DRIFT:** 3µV/°C max
- **LOW NOISE:** 35nV/√Hz
- **LOW INPUT BIAS CURRENT:** 25nA max
- **8-PIN DIP, SO-8, MSOP-8 SURFACE-MOUNT DUAL:** 16-Pin DIP, SO-16, SSOP-16

APPLICATIONS

- **INDUSTRIAL SENSOR AMPLIFIER:** Bridge, RTD, Thermocouple
- **PHYSIOLOGICAL AMPLIFIER:** ECG, EEG, EMG
- **MULTI-CHANNEL DATA ACQUISITION**
- **PORTABLE, BATTERY OPERATED SYSTEMS**

DESCRIPTION

The INA126 and INA2126 are precision instrumentation amplifiers for accurate, low noise differential signal acquisition. Their two-op-amp design provides excellent performance with very low quiescent current (175µA/channel). This, combined with a wide operating voltage range of ±1.35V to ±18V, makes them ideal for portable instrumentation and data acquisition systems.

Gain can be set from 5V/V to 10000V/V with a single external resistor. Laser trimmed input circuitry provides low offset voltage (250µV max), low offset voltage drift (3µV/°C max) and excellent common-mode rejection.

Single version package options include 8-pin plastic DIP, SO-8 surface mount, and fine-pitch MSOP-8 surface-mount. Dual version is available in the space-saving SSOP-16 fine-pitch surface mount, SO-16, and 16-pin DIP. All are specified for the -40°C to +85°C industrial temperature range.

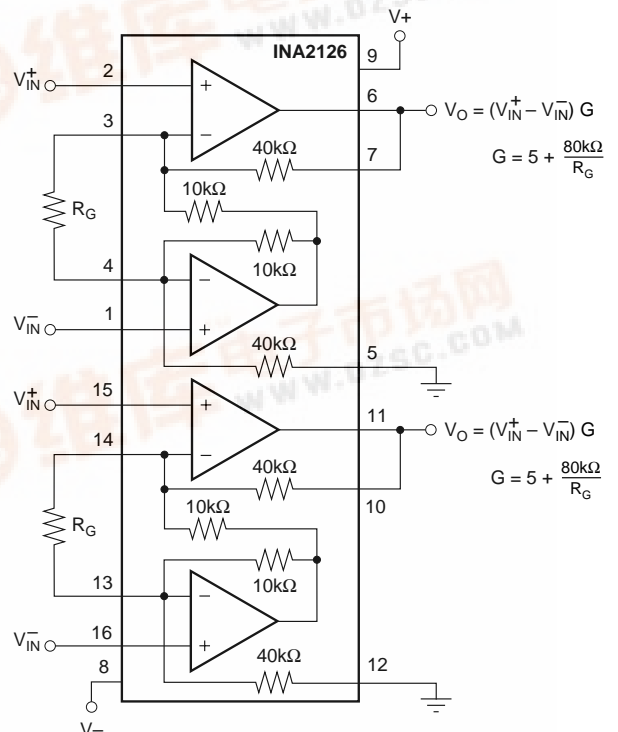
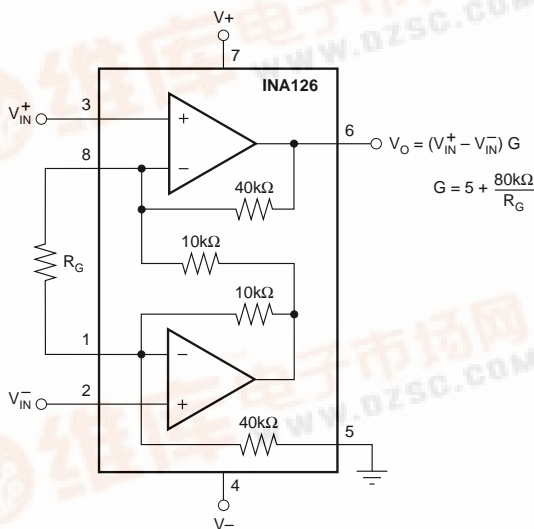

Please be aware that an important notice concerning availability, standard warranty, and use in critical applications of Texas Instruments semiconductor products and disclaimers thereto appears at the end of this data sheet.

All trademarks are the property of their respective owners.

ABSOLUTE MAXIMUM RATINGS⁽¹⁾

Power Supply Voltage, $V+$ to $V-$	36V
Input Signal Voltage ⁽²⁾	$(V-)-0.7$ to $(V+)+0.7V$
Input Signal Current ⁽²⁾	10mA
Output Short Circuit	Continuous
Operating Temperature	-55°C to $+125^{\circ}\text{C}$
Storage Temperature	-55°C to $+125^{\circ}\text{C}$
Lead Temperature (soldering, 10s)	$+300^{\circ}\text{C}$

NOTES: (1) Stresses above these ratings may cause permanent damage.
 (2) Input signal voltage is limited by internal diodes connected to power supplies. See text.

PIN CONFIGURATION (Single)

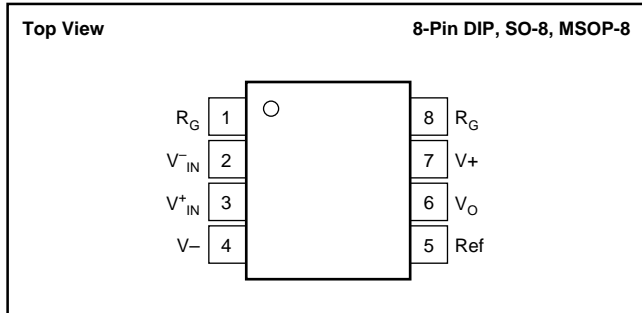

PIN CONFIGURATION (Dual)

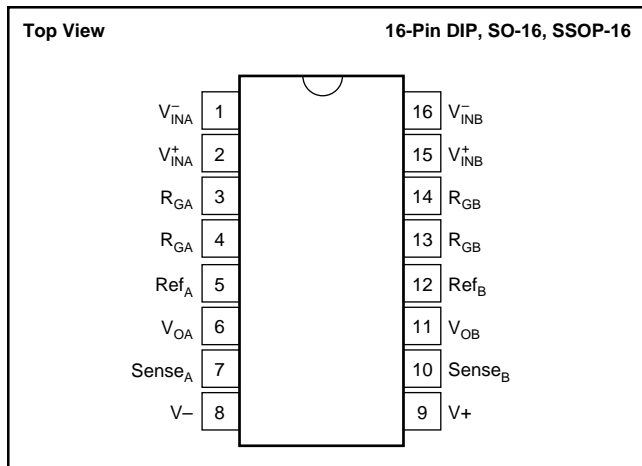

ELECTROSTATIC DISCHARGE SENSITIVITY

This integrated circuit can be damaged by ESD. Texas Instruments recommends that all integrated circuits be handled with appropriate precautions. Failure to observe proper handling and installation procedures can cause damage.

ESD damage can range from subtle performance degradation to complete device failure. Precision integrated circuits may be more susceptible to damage because very small parametric changes could cause the device not to meet its published specifications.

PACKAGE/ORDERING INFORMATION

PRODUCT	PACKAGE-LEAD	PACKAGE MARKING
Single		
INA126PA INA126P	DIP-8 DIP-8	INA126PA INA126P
INA126UA INA126U	SO-8 SO-8	INA126UA INA126U
INA126EA ⁽²⁾ " INA126E ⁽²⁾ "	MSOP-8 " MSOP-8 "	A26 ⁽³⁾ " A26 ⁽³⁾ "
Dual		
INA2126PA INA2126P	DIP-16 DIP-16	INA2126PA INA2126P
INA2126UA INA2126U	SO-16 SO-16	INA2126UA INA2126U
INA2126EA ⁽²⁾ " INA2126E ⁽²⁾ "	SSOP-16 " SSOP-16 "	INA2126EA " INA2126E "

NOTES: (1) For the most current package and ordering information, see the Package Option Addendum at the end of this document, or see the TI website at www.ti.com. (2) MSOP-8 and SSOP-16 packages are available only on 250 or 2500 piece reels. (3) Grade designation is marked on reel.

ELECTRICAL CHARACTERISTICS

At $T_A = +25^\circ\text{C}$, $V_S = \pm 15\text{V}$, $R_L = 25\text{k}\Omega$, unless otherwise noted.

PARAMETER	CONDITIONS	INA126P, U, E INA2126P, U, E			INA126PA, UA, EA INA2126PA, UA, EA			UNITS	
		MIN	TYP	MAX	MIN	TYP	MAX		
INPUT									
Offset Voltage, RTI vs Temperature	$V_S = \pm 1.35\text{V to } \pm 18\text{V}$		± 100	± 250		± 150	± 500	μV	
vs Power Supply (PSRR)			± 0.5	± 3	*	*	± 5	$\mu\text{V}/^\circ\text{C}$	
Input Impedance				5	15	*	*	50	$\mu\text{V}/\text{V}$
Safe Input Voltage		$R_S = 0$	$(V^-) - 0.5$	$10^9 \parallel 4$	$(V^+) + 0.5$	*	*	*	$\Omega \parallel \text{pF}$
Common-Mode Voltage Range	$R_S = 1\text{k}\Omega$	$(V^-) - 10$		$(V^+) + 10$	*	*	*	V	
Channel Separation (dual)	$V_O = 0\text{V}$	± 11.25	± 11.5		*	*		V	
Common-Mode Rejection INA2126U (dual SO-16)	$G = 5, \text{dc}$		130					dB	
	$R_S = 0, V_{CM} = \pm 11.25\text{V}$	83	94		74	90		dB	
		80	94					dB	
INPUT BIAS CURRENT									
vs Temperature			-10	-25		*	-50	nA	
Offset Current			± 30			*		$\text{pA}/^\circ\text{C}$	
vs Temperature			± 0.5	± 2		*	± 5	nA	
			± 10			*		$\text{pA}/^\circ\text{C}$	
GAIN									
Gain Equation			$G = 5 \text{ to } 10\text{k}$			*		V/V	
Gain Error	$V_O = \pm 14\text{V}, G = 5$		$G = 5 + 80\text{k}\Omega/R_G$			*		V/V	
vs Temperature	$G = 5$		± 0.02	± 0.1		*	± 0.18	%	
Gain Error	$V_O = \pm 12\text{V}, G = 100$		± 2	± 10		*	*	$\text{ppm}/^\circ\text{C}$	
vs Temperature	$G = 100$		± 0.2	± 0.5		*	± 1	%	
Nonlinearity	$G = 100, V_O = \pm 14\text{V}$		± 25	± 100		*	*	$\text{ppm}/^\circ\text{C}$	
			± 0.002	± 0.012		*	*	%	
NOISE									
Voltage Noise, $f = 1\text{kHz}$			35			*		$\text{nV}/\sqrt{\text{Hz}}$	
$f = 100\text{Hz}$			35			*		$\text{nV}/\sqrt{\text{Hz}}$	
$f = 10\text{Hz}$			45			*		$\text{nV}/\sqrt{\text{Hz}}$	
$f_B = 0.1\text{Hz to } 10\text{Hz}$			0.7			*		μV_{PP}	
Current Noise, $f = 1\text{kHz}$			60			*		$\text{fA}/\sqrt{\text{Hz}}$	
$f_B = 0.1\text{Hz to } 10\text{Hz}$			2			*		pA_{PP}	
OUTPUT									
Voltage, Positive	$R_L = 25\text{k}\Omega$	$(V^+) - 0.9$	$(V^+) - 0.75$		*	*		V	
Negative	$R_L = 25\text{k}\Omega$	$(V^-) + 0.95$	$(V^-) + 0.8$		*	*		V	
Short-Circuit Current	Short-Circuit to Ground		$+10/-5$			*		mA	
Capacitive Load Drive			1000			*		pF	
FREQUENCY RESPONSE									
Bandwidth, -3dB	$G = 5$		200			*		kHz	
	$G = 100$		9			*		kHz	
	$G = 500$		1.8			*		kHz	
Slew Rate	$V_O = \pm 10\text{V}, G = 5$		0.4			*		V/ μs	
Settling Time, 0.01%	10V Step, $G = 5$		30			*		μs	
	10V Step, $G = 100$		160			*		μs	
	10V Step, $G = 500$		1500			*		μs	
Overload Recovery	50% Input Overload		4			*		μs	
POWER SUPPLY									
Voltage Range		± 1.35	± 15	± 18	*	*	*	V	
Current (per channel)	$I_O = 0$		± 175	± 200		*	*	μA	
TEMPERATURE RANGE									
Specification Range		-40		+85	*		*	$^\circ\text{C}$	
Operation Range		-55		+125	*		*	$^\circ\text{C}$	
Storage Range		-55		+125	*		*	$^\circ\text{C}$	
Thermal Resistance, θ_{JA}								$^\circ\text{C}/\text{W}$	
8-Pin DIP			100			*		$^\circ\text{C}/\text{W}$	
SO-8 Surface-Mount			150			*		$^\circ\text{C}/\text{W}$	
MSOP-8 Surface-Mount			200			*		$^\circ\text{C}/\text{W}$	
16-Pin DIP (dual)			80			*		$^\circ\text{C}/\text{W}$	
SO-16 (dual)			100			*		$^\circ\text{C}/\text{W}$	
SSOP-16 (dual)			100			*		$^\circ\text{C}/\text{W}$	

* Specification same as INA126P, INA126U, INA126E; INA2126P, INA2126U, INA2126E.

TYPICAL CHARACTERISTICS

At $T_A = +25^\circ\text{C}$ and $V_S = \pm 15\text{V}$, unless otherwise noted.

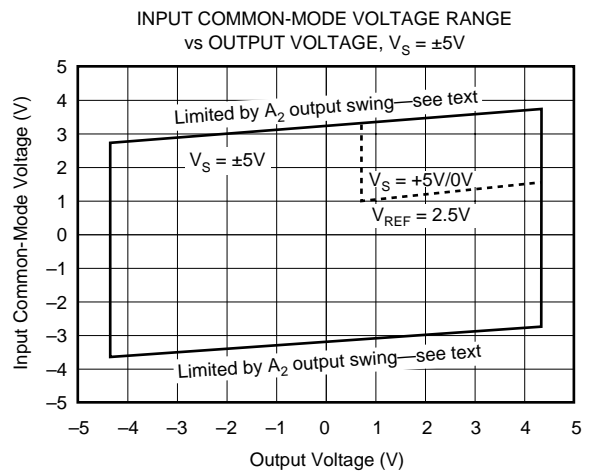
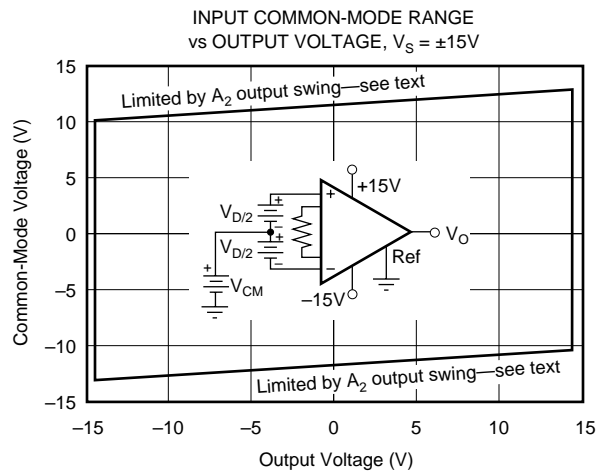
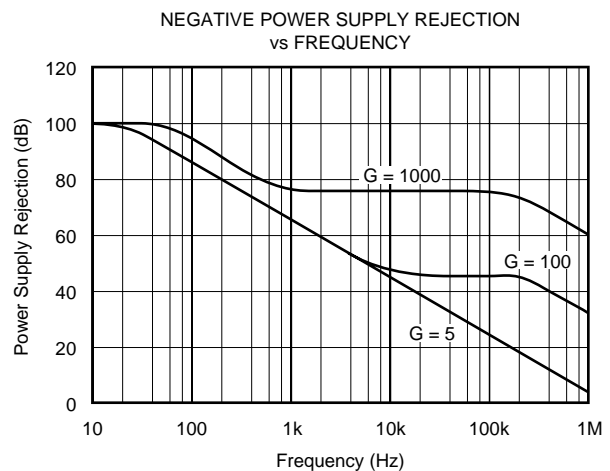
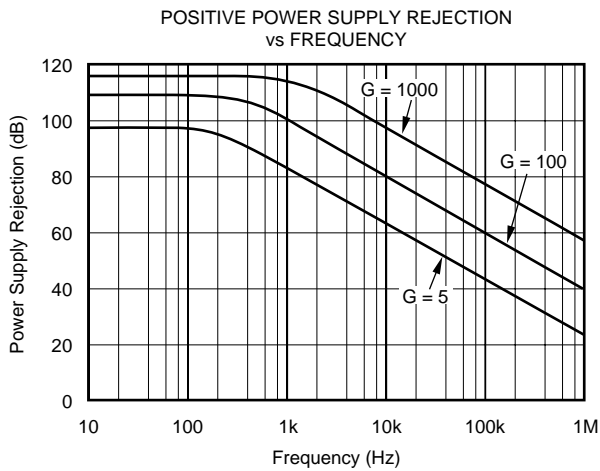
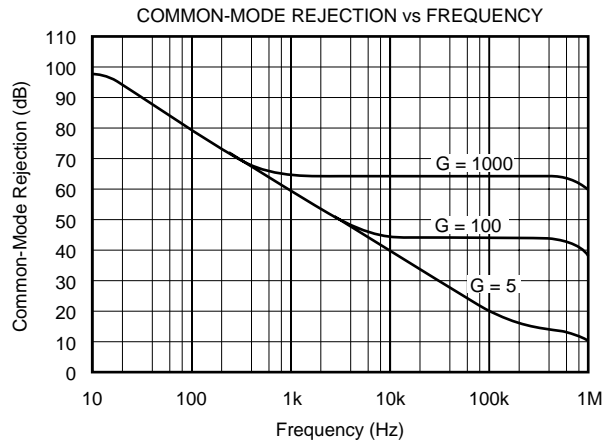
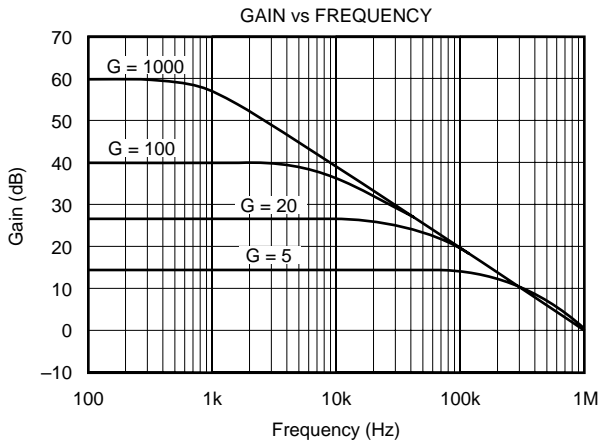

TYPICAL CHARACTERISTICS (Cont.)

At $T_A = +25^\circ\text{C}$ and $V_S = \pm 15\text{V}$, unless otherwise noted.

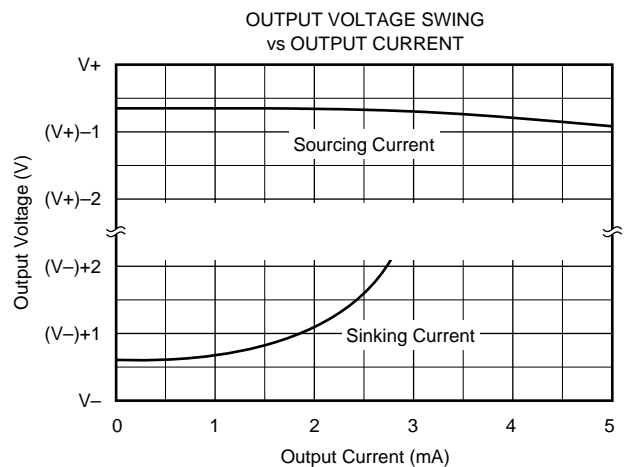
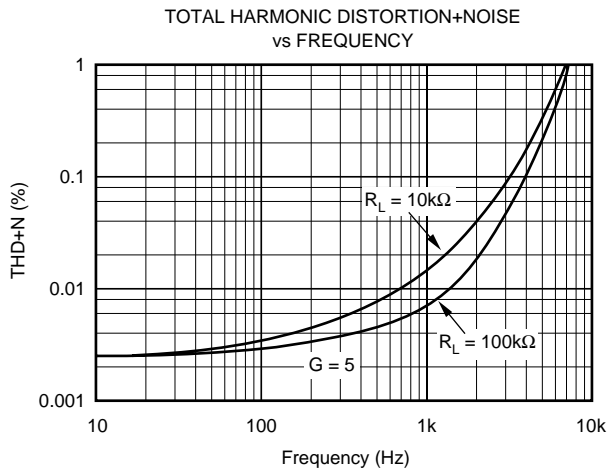
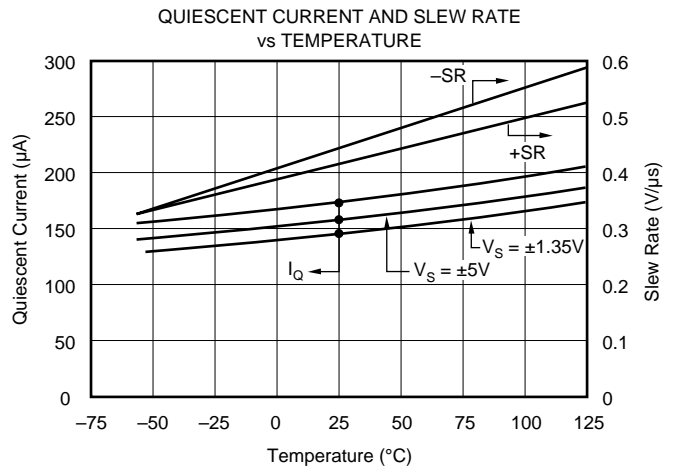
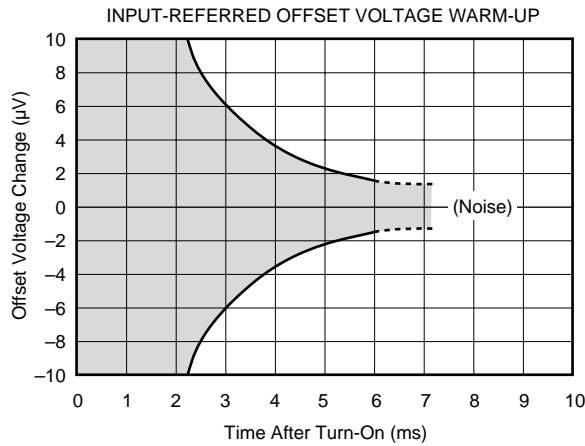
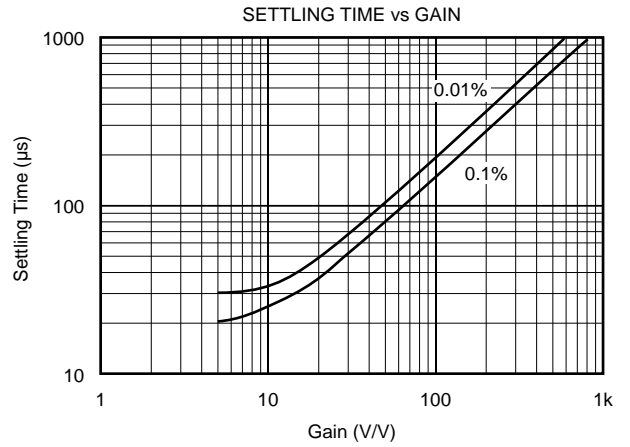
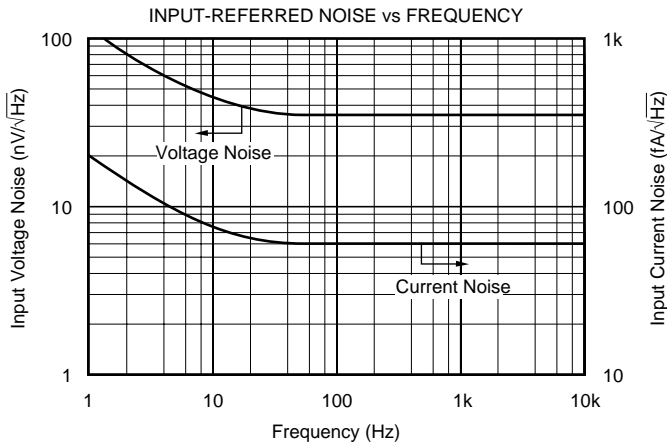

TYPICAL CHARACTERISTICS (Cont.)

At $T_A = +25^\circ\text{C}$ and $V_S = \pm 15\text{V}$, unless otherwise noted.

SMALL-SIGNAL RESPONSE, $G = 5$

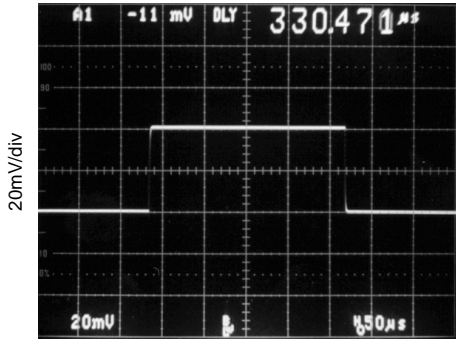

50µs/div

SMALL-SIGNAL RESPONSE, $G = 100$

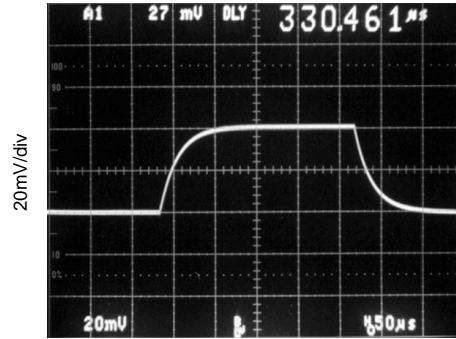

50µs/div

LARGE-SIGNAL RESPONSE, $G = 5$



50µs/div

VOLTAGE NOISE, 0.1Hz to 10Hz

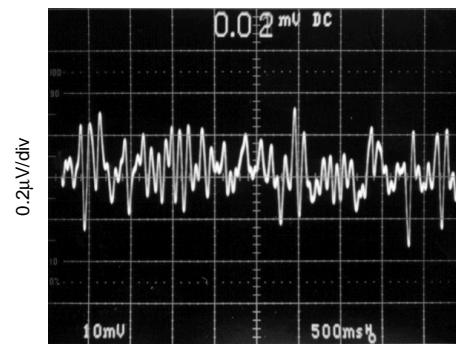

500ms/div

CHANNEL SEPARATION vs FREQUENCY, RTI
(Dual Version)

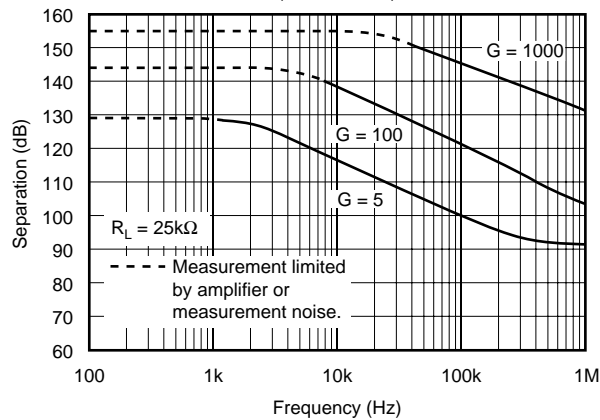

APPLICATION INFORMATION

Figure 1 shows the basic connections required for operation of the INA126. Applications with noisy or high impedance power supplies may require decoupling capacitors close to the device pins as shown.

The output is referred to the output reference (Ref) terminal which is normally grounded. This must be a low-impedance connection to ensure good common-mode rejection. A resistance of 8Ω in series with the Ref pin will cause a typical device to degrade to approximately 80dB CMR.

Dual versions (INA2126) have feedback sense connections, Sense_A and Sense_B. These must be connected to their respective output terminals for proper operation. The sense connection can be used to sense the output voltage directly at the load for best accuracy.

SETTING THE GAIN

Gain is set by connecting an external resistor, R_G, as shown:

$$G = 5 + \frac{80k\Omega}{R_G} \quad (1)$$

Commonly used gains and R_G resistor values are shown in Figure 1.

The 80kΩ term in equation 1 comes from the internal metal film resistors which are laser trimmed to accurate absolute values. The accuracy and temperature coefficient of these resistors are included in the gain accuracy and drift specifications.

The stability and temperature drift of the external gain setting resistor, R_G, also affects gain. R_G's contribution to gain accuracy and drift can be directly inferred from the gain

equation (1). Low resistor values required for high gain can make wiring resistance important. Sockets add to the wiring resistance, which will contribute additional gain error in gains of approximately 100 or greater.

OFFSET TRIMMING

The INA126 and INA2126 are laser trimmed for low offset voltage and offset voltage drift. Most applications require no external offset adjustment. Figure 2 shows an optional circuit for trimming the output offset voltage. The voltage applied to the Ref terminal is added to the output signal. An op amp buffer is used to provide low impedance at the Ref terminal to preserve good common-mode rejection.

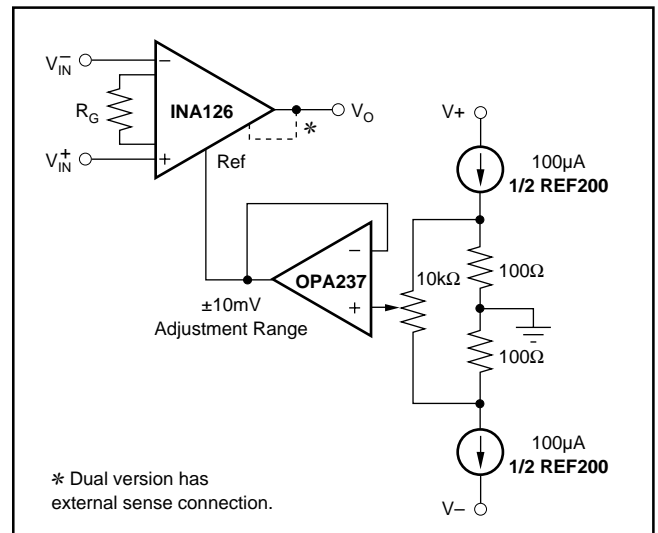

FIGURE 2. Optional Trimming of Output Offset Voltage.

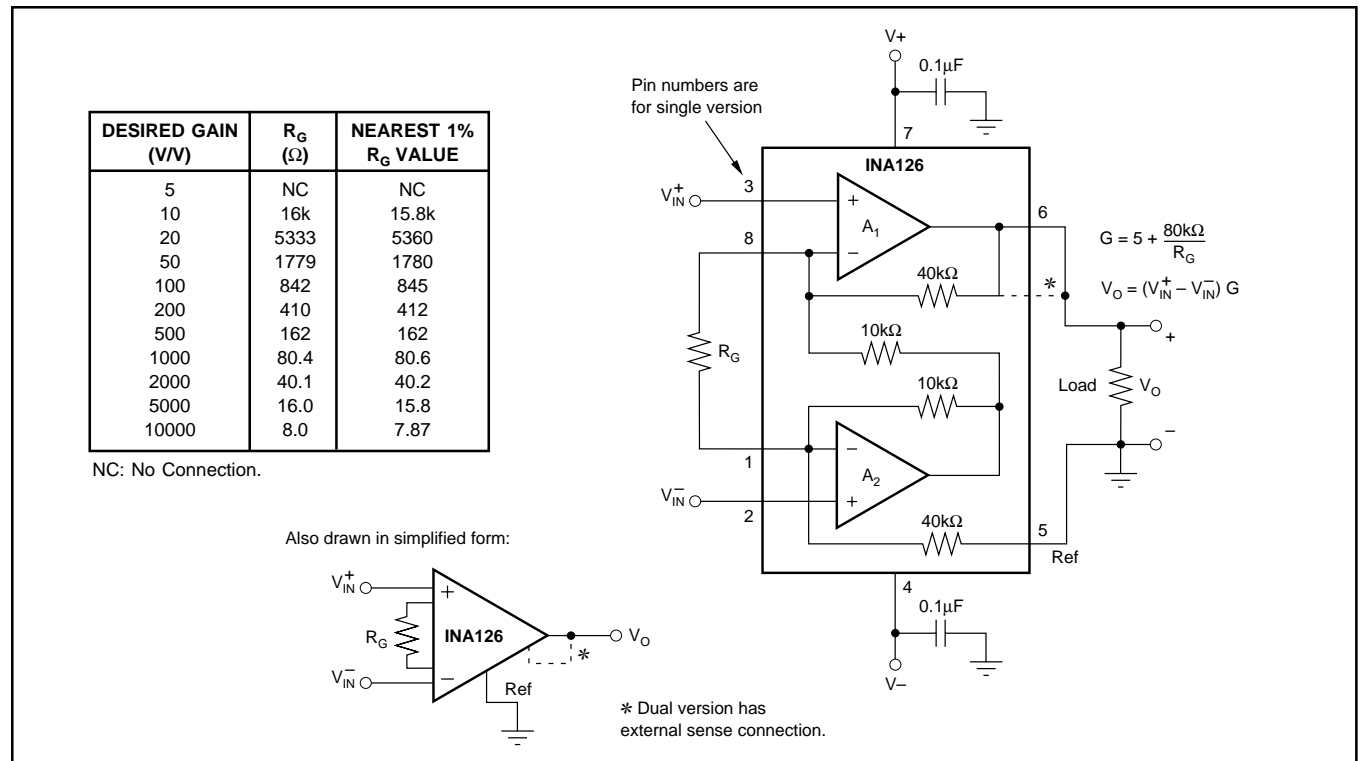

FIGURE 1. Basic Connections.

INPUT BIAS CURRENT RETURN

The input impedance of the INA126/2126 is extremely high—approximately $10^9\Omega$. However, a path must be provided for the input bias current of both inputs. This input bias current is typically -10nA (current flows out of the input terminals). High input impedance means that this input bias current changes very little with varying input voltage.

Input circuitry must provide a path for this input bias current for proper operation. Figure 3 shows various provisions for an input bias current path. Without a bias current path, the inputs will float to a potential which exceeds the common-mode range and the input amplifiers will saturate.

If the differential source resistance is low, the bias current return path can be connected to one input (see the thermocouple example in Figure 3). With higher source impedance, using two equal resistors provides a balanced input with advantages of lower input offset voltage due to bias current and better high-frequency common-mode rejection.

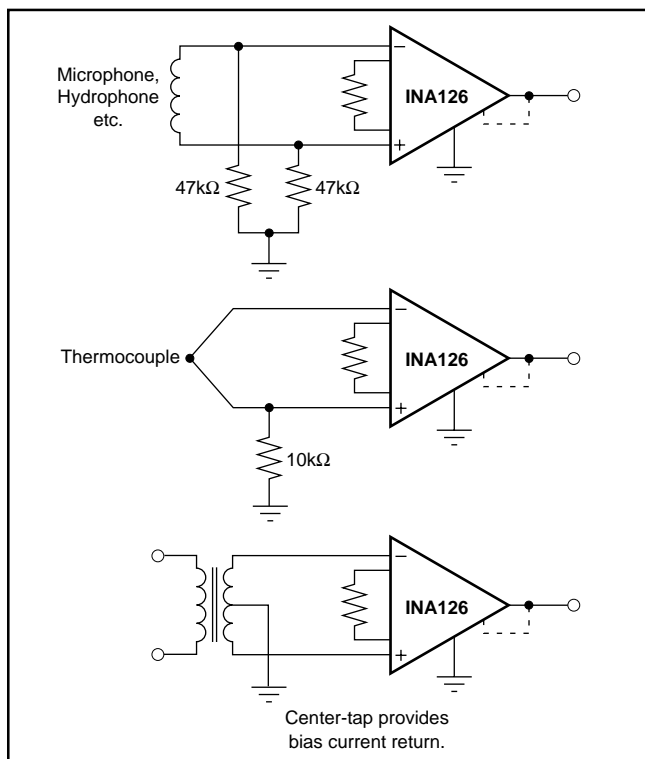

FIGURE 3. Providing an Input Common-Mode Current Path.

INPUT COMMON-MODE RANGE

The input common-mode range of the INA126/2126 is shown in the typical characteristic curves. The common-mode range is limited on the negative side by the output voltage swing of A_2 , an internal circuit node that cannot be measured on an external pin. The output voltage of A_2 can be expressed as:

$$V_{O2} = 1.25 V_{IN}^- - (V_{IN}^+ - V_{IN}^-) (10\text{k}\Omega/R_G) \quad (2)$$

(Voltages referred to Ref terminal, pin 5)

The internal op amp A_2 is identical to A_1 and its output swing is limited to typically 0.7V from the supply rails. When the input common-mode range is exceeded (A_2 's output is saturated), A_1 can still be in linear operation and respond to changes in the non-inverting input voltage. The output voltage, however, will be invalid.

LOW VOLTAGE OPERATION

The INA126/2126 can be operated on power supplies as low as $\pm 1.35\text{V}$. Performance remains excellent with power supplies ranging from $\pm 1.35\text{V}$ to $\pm 18\text{V}$. Most parameters vary only slightly throughout this supply voltage range—see typical characteristic curves. Operation at very low supply voltage requires careful attention to ensure that the common-mode voltage remains within its linear range. See “Input Common-Mode Voltage Range.”

The INA126/2126 can be operated from a single power supply with careful attention to input common-mode range, output voltage swing of both op amps and the voltage applied to the Ref terminal. Figure 4 shows a bridge amplifier circuit operated from a single $+5\text{V}$ power supply. The bridge provides an input common-mode voltage near 2.5V , with a relatively small differential voltage.

INPUT PROTECTION

The inputs are protected with internal diodes connected to the power supply rails. These diodes will clamp the applied signal to prevent it from exceeding the power supplies by more than approximately 0.7V . If the signal source voltage can exceed the power supplies, the source current should be limited to less than 10mA . This can generally be done with a series resistor. Some signal sources are inherently current-limited and do not require limiting resistors.

CHANNEL CROSSTALK—DUAL VERSION

The two channels of the INA2126 are completely independent, including all bias circuitry. At DC and low frequency there is virtually no signal coupling between channels. Crosstalk increases with frequency and is dependent on circuit gain, source impedance and signal characteristics.

As source impedance increases, careful circuit layout will help achieve lowest channel crosstalk. Most crosstalk is produced by capacitive coupling of signals from one channel to the input section of the other channel. To minimize coupling, separate the input traces as far as practical from any signals associated with the opposite channel. A grounded guard trace surrounding the inputs helps reduce stray coupling between channels. Carefully balance the stray capacitance of each input to ground, and run the differential inputs of each channel parallel to each other, or directly adjacent on top and bottom side of a circuit board. Stray coupling then tends to produce a common-mode signal that is rejected by the IA's input.

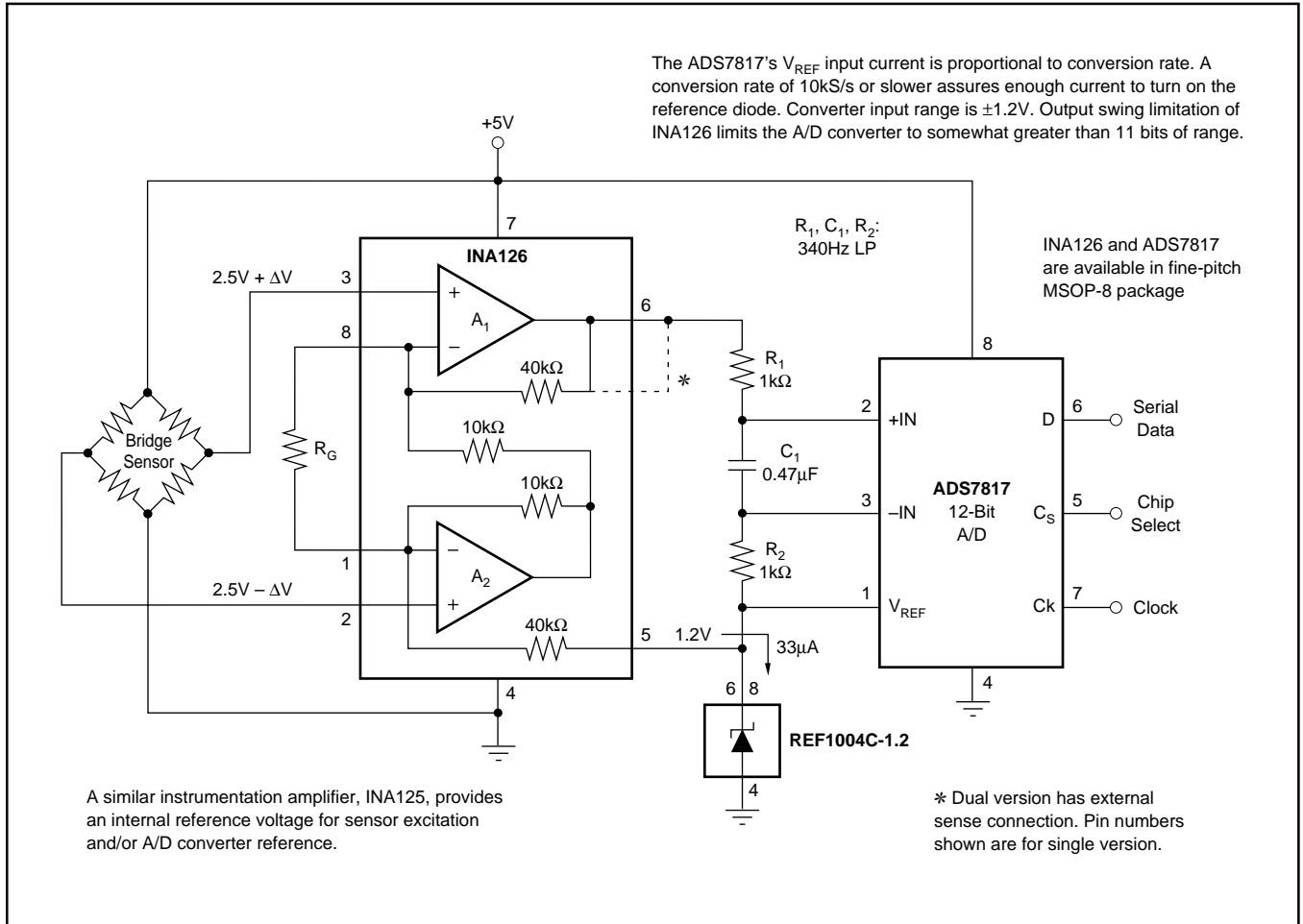

FIGURE 4. Bridge Signal Acquisition—Single 5V Supply.

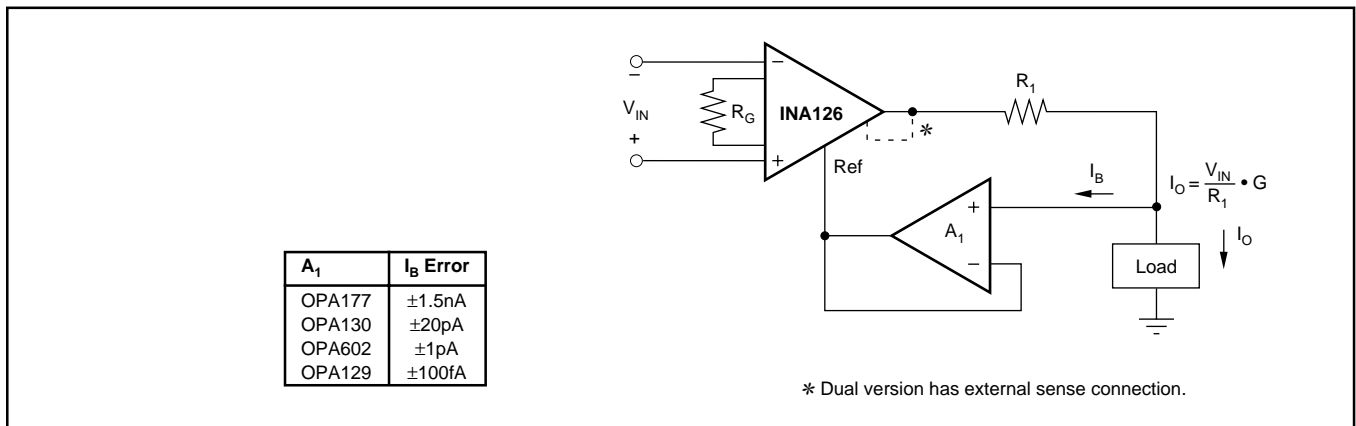

FIGURE 5. Differential Voltage-to-Current Converter.

PACKAGING INFORMATION

Orderable Device	Status ⁽¹⁾	Package Type	Package Drawing	Pins	Package Qty	Eco Plan ⁽²⁾	Lead/Ball Finish	MSL Peak Temp ⁽³⁾
INA126E/250	ACTIVE	MSOP	DGK	8	250	Green (RoHS & no Sb/Br)	CU NIPDAU	Level-2-260C-1 YEAR
INA126E/250G4	ACTIVE	MSOP	DGK	8	250	Green (RoHS & no Sb/Br)	CU NIPDAU	Level-2-260C-1 YEAR
INA126E/2K5	ACTIVE	MSOP	DGK	8	2500	Green (RoHS & no Sb/Br)	CU NIPDAU	Level-2-260C-1 YEAR
INA126E/2K5G4	ACTIVE	MSOP	DGK	8	2500	Green (RoHS & no Sb/Br)	CU NIPDAU	Level-2-260C-1 YEAR
INA126EA/250	ACTIVE	MSOP	DGK	8	250	Green (RoHS & no Sb/Br)	CU NIPDAU	Level-2-260C-1 YEAR
INA126EA/250G4	ACTIVE	MSOP	DGK	8	250	Green (RoHS & no Sb/Br)	CU NIPDAU	Level-2-260C-1 YEAR
INA126EA/2K5	ACTIVE	MSOP	DGK	8	2500	Green (RoHS & no Sb/Br)	CU NIPDAU	Level-2-260C-1 YEAR
INA126EA/2K5G4	ACTIVE	MSOP	DGK	8	2500	Green (RoHS & no Sb/Br)	CU NIPDAU	Level-2-260C-1 YEAR
INA126P	ACTIVE	PDIP	P	8	50	Green (RoHS & no Sb/Br)	CU NIPDAU	N / A for Pkg Type
INA126PA	ACTIVE	PDIP	P	8	50	Green (RoHS & no Sb/Br)	CU NIPDAU	N / A for Pkg Type
INA126PAG4	ACTIVE	PDIP	P	8	50	Green (RoHS & no Sb/Br)	CU NIPDAU	N / A for Pkg Type
INA126PG4	ACTIVE	PDIP	P	8	50	Green (RoHS & no Sb/Br)	CU NIPDAU	N / A for Pkg Type
INA126U	ACTIVE	SOIC	D	8	100	Green (RoHS & no Sb/Br)	CU NIPDAU	Level-3-260C-168 HR
INA126U/2K5	ACTIVE	SOIC	D	8	2500	Green (RoHS & no Sb/Br)	CU NIPDAU	Level-3-260C-168 HR
INA126U/2K5G4	ACTIVE	SOIC	D	8	2500	Green (RoHS & no Sb/Br)	CU NIPDAU	Level-3-260C-168 HR
INA126UA	ACTIVE	SOIC	D	8	100	Green (RoHS & no Sb/Br)	CU NIPDAU	Level-3-260C-168 HR
INA126UA/2K5	ACTIVE	SOIC	D	8	2500	Pb-Free (RoHS)	CU NIPDAU	Level-3-260C-168 HR
INA126UA/2K5E4	ACTIVE	SOIC	D	8	2500	Pb-Free (RoHS)	CU NIPDAU	Level-3-260C-168 HR
INA126UAG4	ACTIVE	SOIC	D	8	100	Green (RoHS & no Sb/Br)	CU NIPDAU	Level-3-260C-168 HR
INA126UG4	ACTIVE	SOIC	D	8	100	Green (RoHS & no Sb/Br)	CU NIPDAU	Level-3-260C-168 HR
INA2126E/250	ACTIVE	SSOP/ QSOP	DBQ	16	250	Green (RoHS & no Sb/Br)	CU NIPDAU	Level-3-260C-168 HR
INA2126E/250G4	ACTIVE	SSOP/ QSOP	DBQ	16	250	Green (RoHS & no Sb/Br)	CU NIPDAU	Level-3-260C-168 HR
INA2126E/2K5	ACTIVE	SSOP/ QSOP	DBQ	16	2500	Green (RoHS & no Sb/Br)	CU NIPDAU	Level-3-260C-168 HR
INA2126E/2K5G4	ACTIVE	SSOP/ QSOP	DBQ	16	2500	Green (RoHS & no Sb/Br)	CU NIPDAU	Level-3-260C-168 HR
INA2126EA/250	ACTIVE	SSOP/ QSOP	DBQ	16	250	Green (RoHS & no Sb/Br)	CU NIPDAU	Level-3-260C-168 HR

Orderable Device	Status ⁽¹⁾	Package Type	Package Drawing	Pins	Package Qty	Eco Plan ⁽²⁾	Lead/Ball Finish	MSL Peak Temp ⁽³⁾
INA2126EA/250G4	ACTIVE	SSOP/ QSOP	DBQ	16	250	Green (RoHS & no Sb/Br)	CU NIPDAU	Level-3-260C-168 HR
INA2126EA/2K5	ACTIVE	SSOP/ QSOP	DBQ	16	2500	Green (RoHS & no Sb/Br)	CU NIPDAU	Level-3-260C-168 HR
INA2126EA/2K5G4	ACTIVE	SSOP/ QSOP	DBQ	16	2500	Green (RoHS & no Sb/Br)	CU NIPDAU	Level-3-260C-168 HR
INA2126P	ACTIVE	PDIP	N	16	25	Green (RoHS & no Sb/Br)	Call TI	N / A for Pkg Type
INA2126PA	ACTIVE	PDIP	N	16	25	Green (RoHS & no Sb/Br)	Call TI	N / A for Pkg Type
INA2126PAG4	ACTIVE	PDIP	N	16	25	Green (RoHS & no Sb/Br)	Call TI	N / A for Pkg Type
INA2126PG4	ACTIVE	PDIP	N	16	25	Green (RoHS & no Sb/Br)	Call TI	N / A for Pkg Type
INA2126U	ACTIVE	SOIC	D	16	48	Pb-Free (RoHS)	CU NIPDAU	Level-3-260C-168 HR
INA2126UA	ACTIVE	SOIC	D	16	48	Green (RoHS & no Sb/Br)	CU NIPDAU	Level-3-260C-168 HR
INA2126UA/2K5	ACTIVE	SOIC	D	16	2500	Pb-Free (RoHS)	CU NIPDAU	Level-3-260C-168 HR
INA2126UA/2K5E4	ACTIVE	SOIC	D	16	2500	Pb-Free (RoHS)	CU NIPDAU	Level-3-260C-168 HR
INA2126UAE4	ACTIVE	SOIC	D	16	48	Pb-Free (RoHS)	CU NIPDAU	Level-3-260C-168 HR
INA2126UAG4	ACTIVE	SOIC	D	16	48	Green (RoHS & no Sb/Br)	CU NIPDAU	Level-3-260C-168 HR
INA2126UE4	ACTIVE	SOIC	D	16	48	Pb-Free (RoHS)	CU NIPDAU	Level-3-260C-168 HR
SN200501036DRE4	ACTIVE	SOIC	D	16	2500	Pb-Free (RoHS)	CU NIPDAU	Level-3-260C-168 HR

⁽¹⁾ The marketing status values are defined as follows:

ACTIVE: Product device recommended for new designs.

LIFEBUY: TI has announced that the device will be discontinued, and a lifetime-buy period is in effect.

NRND: Not recommended for new designs. Device is in production to support existing customers, but TI does not recommend using this part in a new design.

PREVIEW: Device has been announced but is not in production. Samples may or may not be available.

OBSELETE: TI has discontinued the production of the device.

⁽²⁾ Eco Plan - The planned eco-friendly classification: Pb-Free (RoHS), Pb-Free (RoHS Exempt), or Green (RoHS & no Sb/Br) - please check <http://www.ti.com/productcontent> for the latest availability information and additional product content details.

TBD: The Pb-Free/Green conversion plan has not been defined.

Pb-Free (RoHS): TI's terms "Lead-Free" or "Pb-Free" mean semiconductor products that are compatible with the current RoHS requirements for all 6 substances, including the requirement that lead not exceed 0.1% by weight in homogeneous materials. Where designed to be soldered at high temperatures, TI Pb-Free products are suitable for use in specified lead-free processes.

Pb-Free (RoHS Exempt): This component has a RoHS exemption for either 1) lead-based flip-chip solder bumps used between the die and package, or 2) lead-based die adhesive used between the die and leadframe. The component is otherwise considered Pb-Free (RoHS compatible) as defined above.

Green (RoHS & no Sb/Br): TI defines "Green" to mean Pb-Free (RoHS compatible), and free of Bromine (Br) and Antimony (Sb) based flame retardants (Br or Sb do not exceed 0.1% by weight in homogeneous material)

⁽³⁾ MSL, Peak Temp. -- The Moisture Sensitivity Level rating according to the JEDEC industry standard classifications, and peak solder temperature.

Important Information and Disclaimer: The information provided on this page represents TI's knowledge and belief as of the date that it is

provided. TI bases its knowledge and belief on information provided by third parties, and makes no representation or warranty as to the accuracy of such information. Efforts are underway to better integrate information from third parties. TI has taken and continues to take reasonable steps to provide representative and accurate information but may not have conducted destructive testing or chemical analysis on incoming materials and chemicals. TI and TI suppliers consider certain information to be proprietary, and thus CAS numbers and other limited information may not be available for release.

In no event shall TI's liability arising out of such information exceed the total purchase price of the TI part(s) at issue in this document sold by TI to Customer on an annual basis.

MECHANICAL DATA

MPDI001A – JANUARY 1995 – REVISED JUNE 1999

P (R-PDIP-T8)

PLASTIC DUAL-IN-LINE

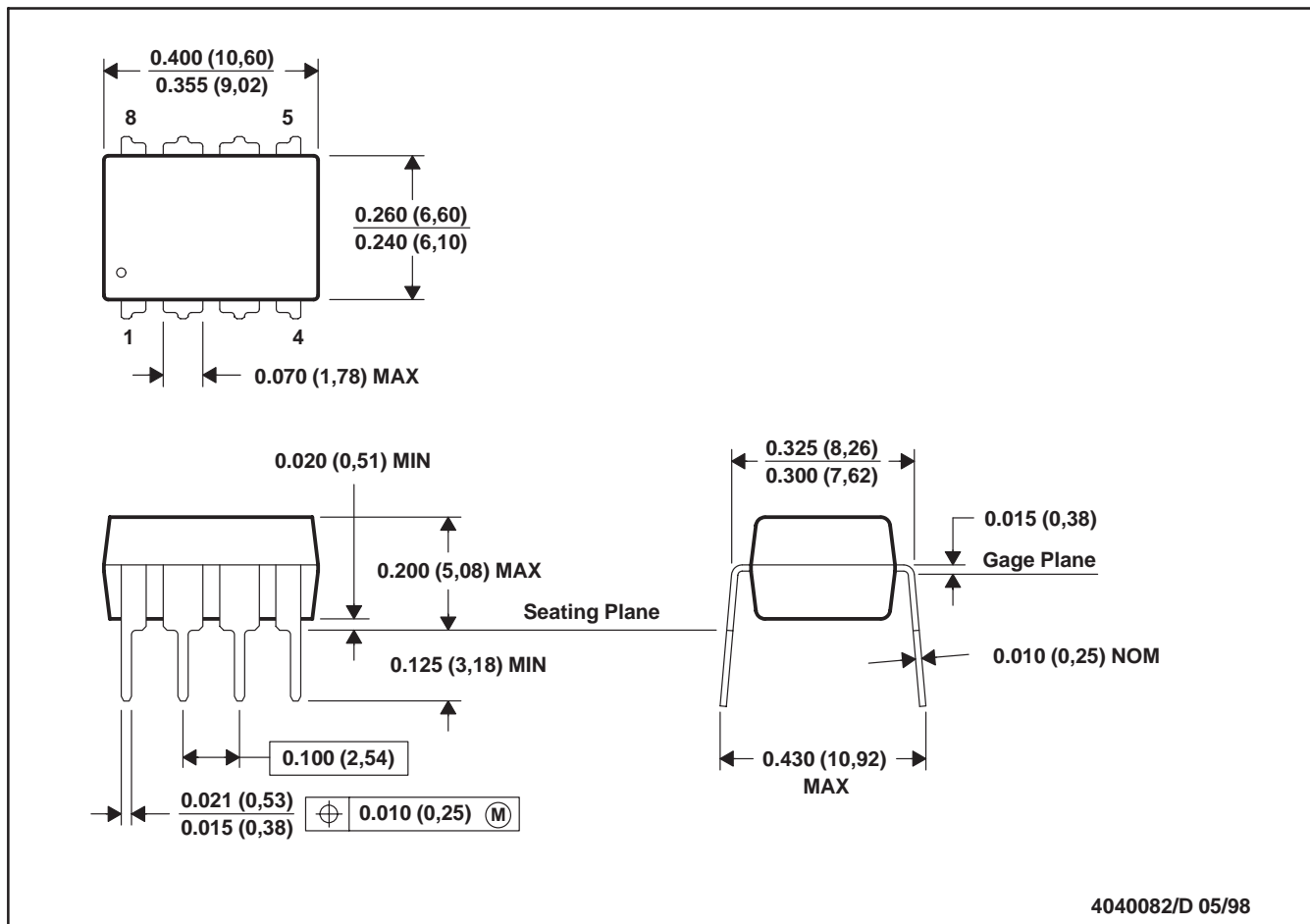

4040082/D 05/98

- NOTES: A. All linear dimensions are in inches (millimeters).
 B. This drawing is subject to change without notice.
 C. Falls within JEDEC MS-001

MECHANICAL DATA

N (R-PDIP-T**)

16 PINS SHOWN

PLASTIC DUAL-IN-LINE PACKAGE

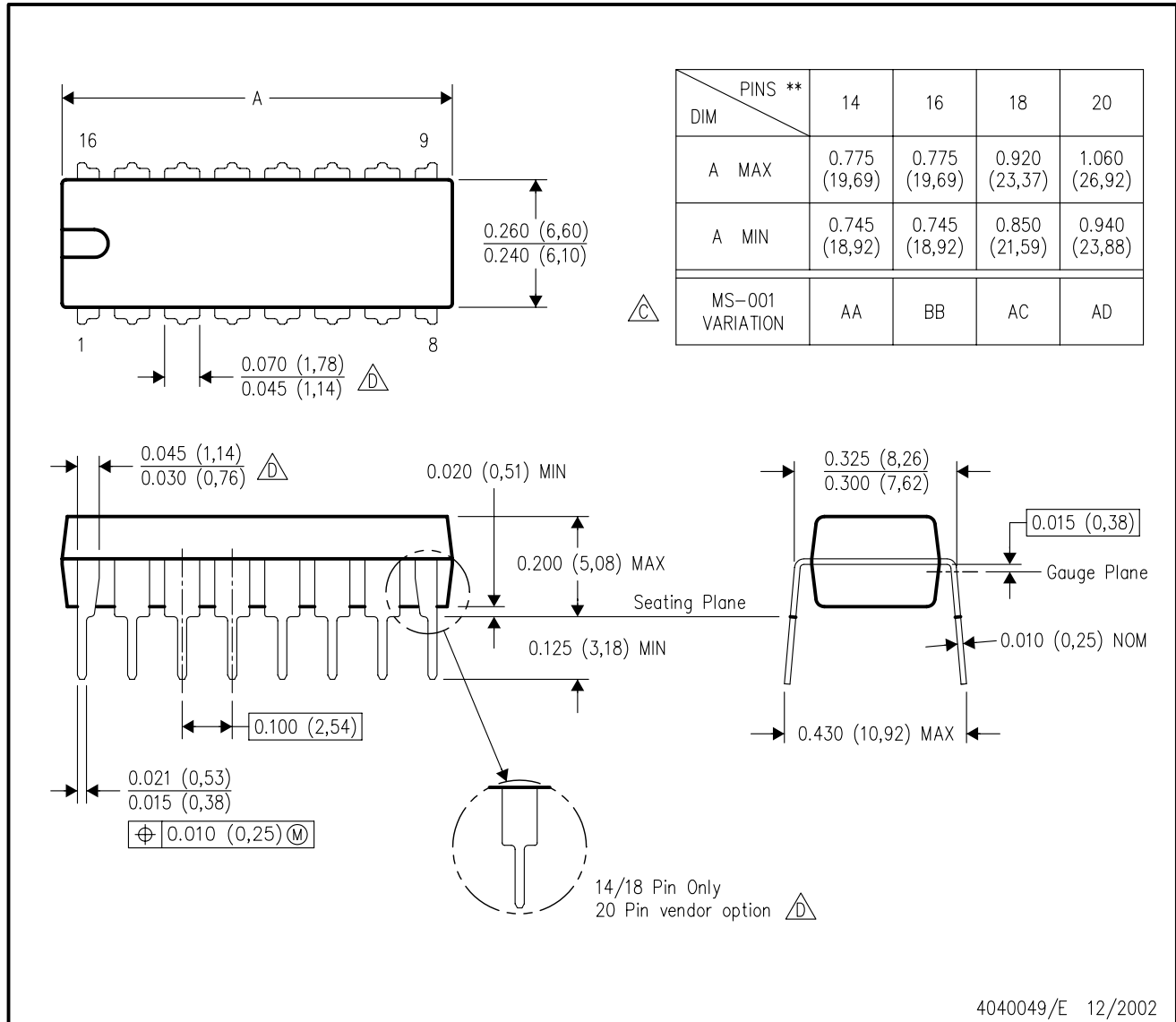

- NOTES:
- A. All linear dimensions are in inches (millimeters).
 - B. This drawing is subject to change without notice.
 - Falls within JEDEC MS-001, except 18 and 20 pin minimum body length (Dim A).
 - The 20 pin end lead shoulder width is a vendor option, either half or full width.

MECHANICAL DATA

DGK (S-PDSO-G8)

PLASTIC SMALL-OUTLINE PACKAGE

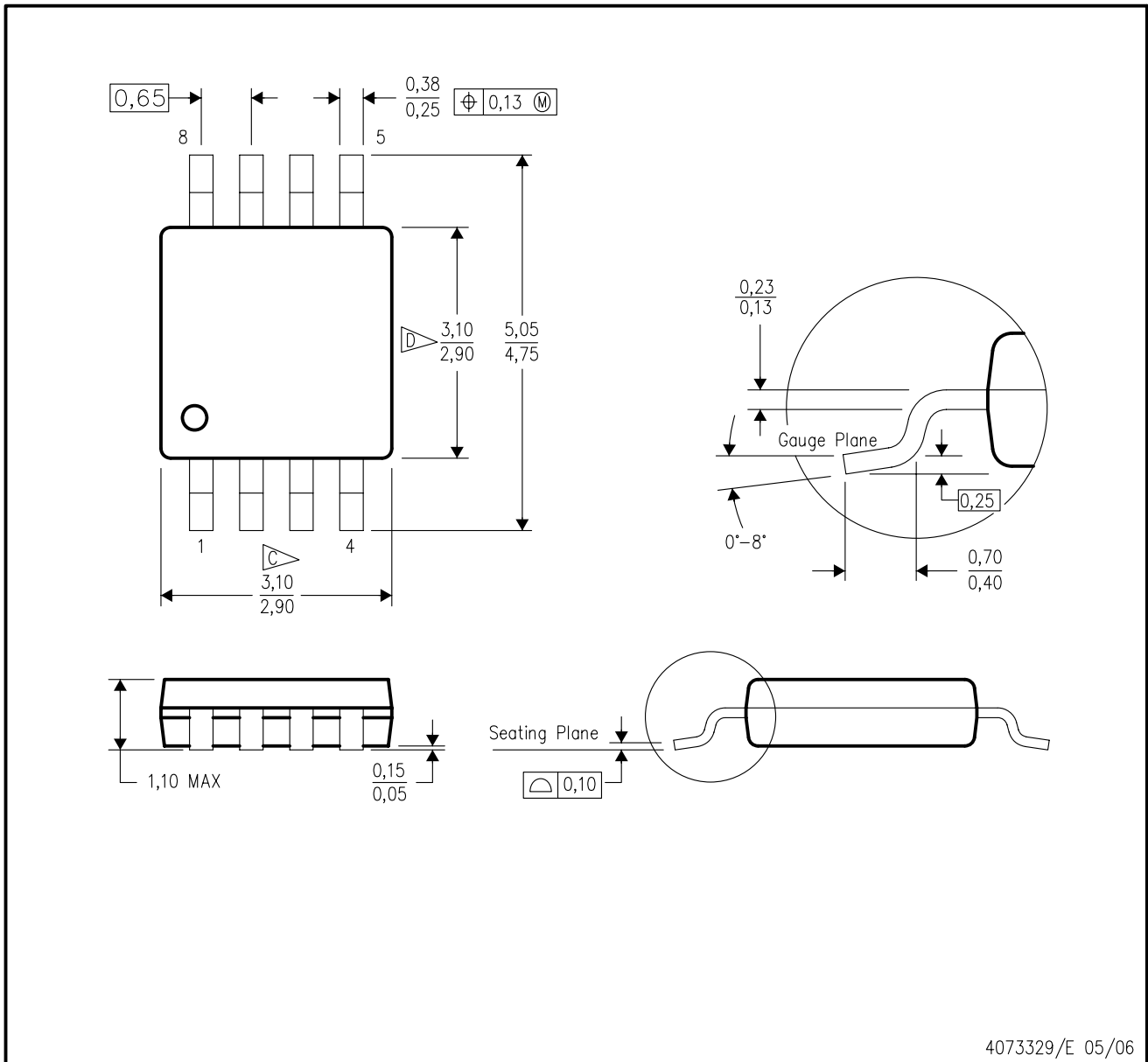

- NOTES:
- A. All linear dimensions are in millimeters.
 - B. This drawing is subject to change without notice.
 - C. Body length does not include mold flash, protrusions, or gate burrs. Mold flash, protrusions, or gate burrs shall not exceed 0.15 per end.
 - D. Body width does not include interlead flash. Interlead flash shall not exceed 0.50 per side.
 - E. Falls within JEDEC MO-187 variation AA, except interlead flash.

MECHANICAL DATA

D (R-PDSO-G16)

PLASTIC SMALL-OUTLINE PACKAGE

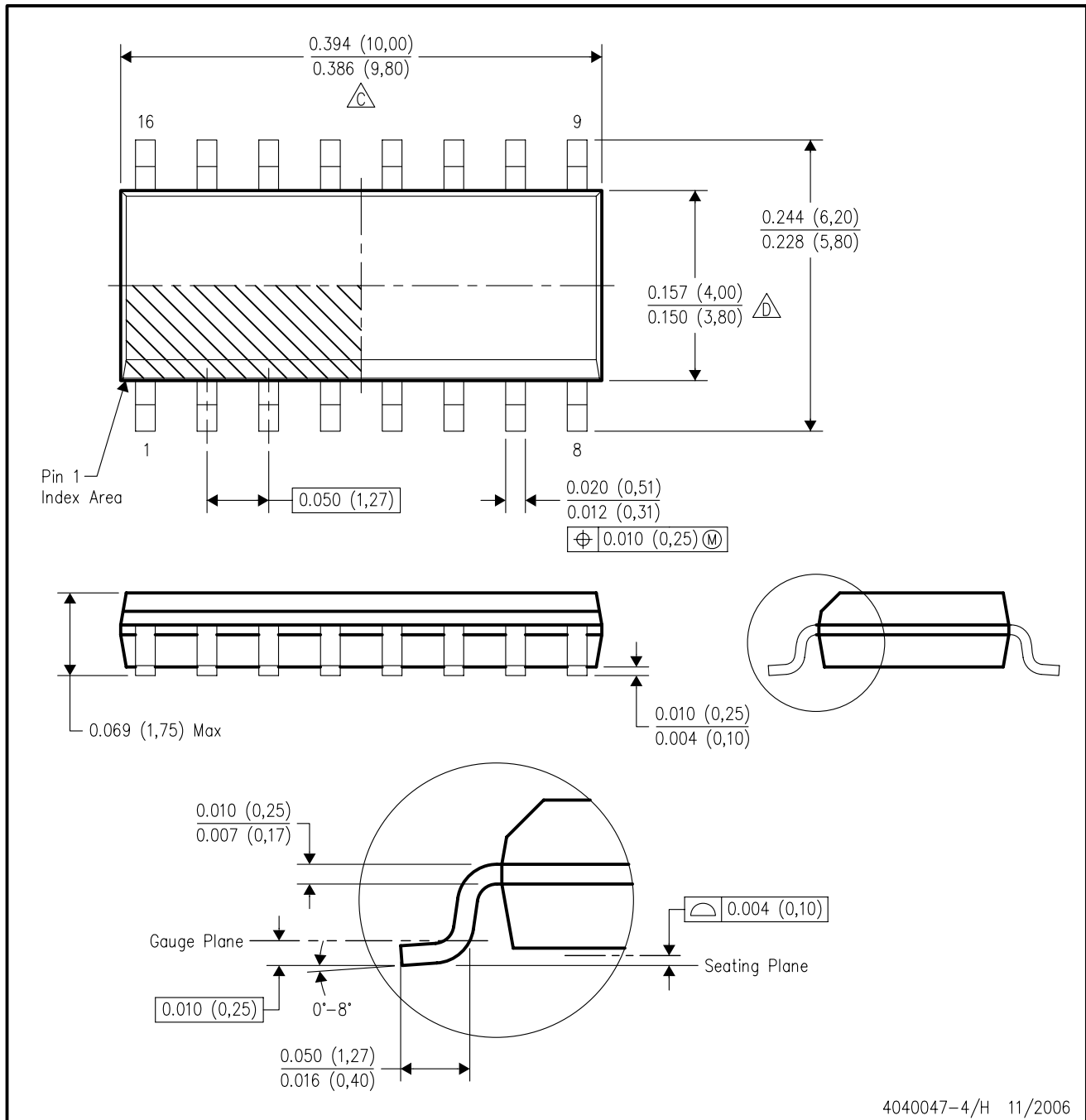

4040047-4/H 11/2006

- NOTES:
- A. All linear dimensions are in inches (millimeters).
 - B. This drawing is subject to change without notice.
 - $\triangle C$ Body length does not include mold flash, protrusions, or gate burrs. Mold flash, protrusions, or gate burrs shall not exceed .006 (0,15) per end.
 - $\triangle D$ Body width does not include interlead flash. Interlead flash shall not exceed .017 (0,43) per side.
 - E. Reference JEDEC MS-012 variation AC.

MECHANICAL DATA

D (R-PDSO-G8)

PLASTIC SMALL-OUTLINE PACKAGE

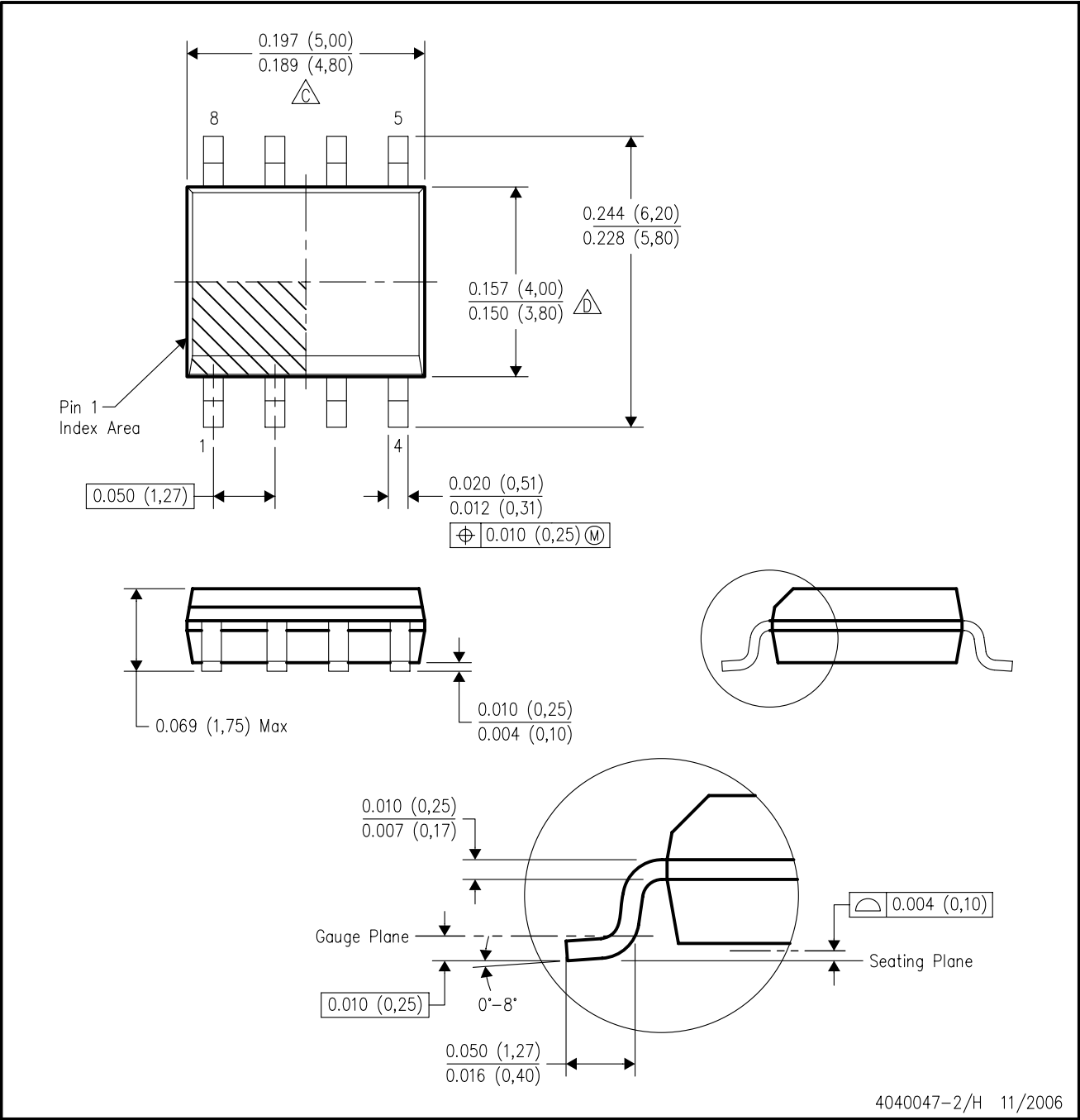

4040047-2/H 11/2006

- NOTES:
- A. All linear dimensions are in inches (millimeters).
 - B. This drawing is subject to change without notice.
 - C. Body length does not include mold flash, protrusions, or gate burrs. Mold flash, protrusions, or gate burrs shall not exceed .006 (0,15) per end.
 - D. Body width does not include interlead flash. Interlead flash shall not exceed .017 (0,43) per side.
 - E. Reference JEDEC MS-012 variation AA.

MECHANICAL DATA

DBQ (R-PDSO-G16)

PLASTIC SMALL-OUTLINE PACKAGE

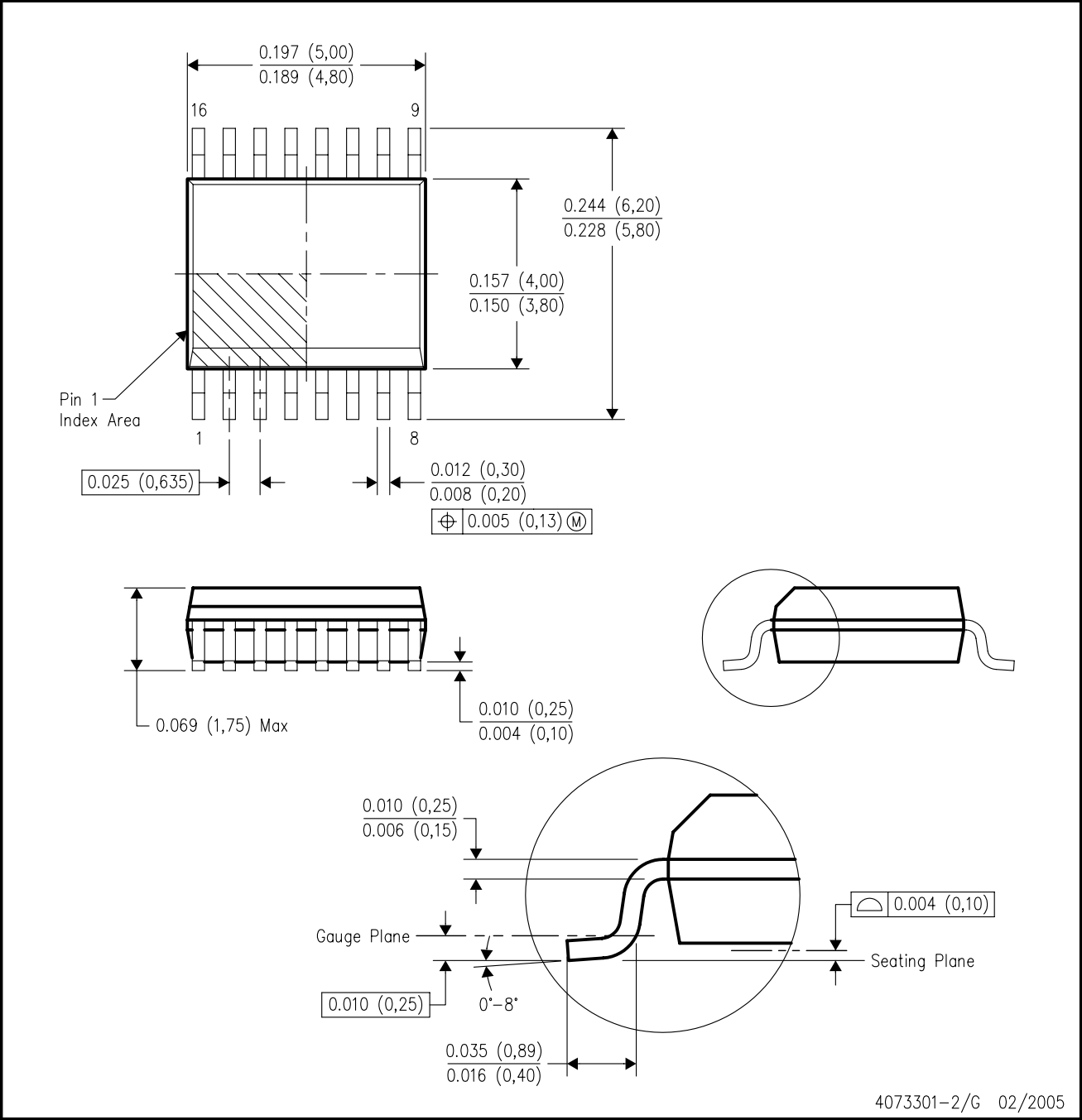

4073301-2/G 02/2005

- NOTES:
- A. All linear dimensions are in inches (millimeters).
 - B. This drawing is subject to change without notice.
 - C. Body dimensions do not include mold flash or protrusion not to exceed 0.006 (0,15) per side.
 - D. Falls within JEDEC MO-137 variation AB.

IMPORTANT NOTICE

Texas Instruments Incorporated and its subsidiaries (TI) reserve the right to make corrections, modifications, enhancements, improvements, and other changes to its products and services at any time and to discontinue any product or service without notice. Customers should obtain the latest relevant information before placing orders and should verify that such information is current and complete. All products are sold subject to TI's terms and conditions of sale supplied at the time of order acknowledgment.

TI warrants performance of its hardware products to the specifications applicable at the time of sale in accordance with TI's standard warranty. Testing and other quality control techniques are used to the extent TI deems necessary to support this warranty. Except where mandated by government requirements, testing of all parameters of each product is not necessarily performed.

TI assumes no liability for applications assistance or customer product design. Customers are responsible for their products and applications using TI components. To minimize the risks associated with customer products and applications, customers should provide adequate design and operating safeguards.

TI does not warrant or represent that any license, either express or implied, is granted under any TI patent right, copyright, mask work right, or other TI intellectual property right relating to any combination, machine, or process in which TI products or services are used. Information published by TI regarding third-party products or services does not constitute a license from TI to use such products or services or a warranty or endorsement thereof. Use of such information may require a license from a third party under the patents or other intellectual property of the third party, or a license from TI under the patents or other intellectual property of TI.

Reproduction of information in TI data books or data sheets is permissible only if reproduction is without alteration and is accompanied by all associated warranties, conditions, limitations, and notices. Reproduction of this information with alteration is an unfair and deceptive business practice. TI is not responsible or liable for such altered documentation.

Resale of TI products or services with statements different from or beyond the parameters stated by TI for that product or service voids all express and any implied warranties for the associated TI product or service and is an unfair and deceptive business practice. TI is not responsible or liable for any such statements.

Following are URLs where you can obtain information on other Texas Instruments products and application solutions:

Products

Amplifiers	amplifier.ti.com
Data Converters	dataconverter.ti.com
DSP	dsp.ti.com
Interface	interface.ti.com
Logic	logic.ti.com
Power Mgmt	power.ti.com
Microcontrollers	microcontroller.ti.com
Low Power Wireless	www.ti.com/lpw

Applications

Audio	www.ti.com/audio
Automotive	www.ti.com/automotive
Broadband	www.ti.com/broadband
Digital Control	www.ti.com/digitalcontrol
Military	www.ti.com/military
Optical Networking	www.ti.com/opticalnetwork
Security	www.ti.com/security
Telephony	www.ti.com/telephony
Video & Imaging	www.ti.com/video
Wireless	www.ti.com/wireless

Mailing Address: Texas Instruments
Post Office Box 655303 Dallas, Texas 75265