

INA203 INA204 INA205

SBOS393–MARCH 2007

Unidirectional Measurement Current-Shunt Monitor with Dual Comparators

FEATURES

- COMPLETE CURRENT SENSE SOLUTION
- DUAL COMPARATORS:
 - Comparator 1 with Latch
 - Comparator 2 with Optional Delay
- COMMON-MODE RANGE: -16V to $+80\text{V}$
- HIGH ACCURACY: 3.5% (max) Over Temperature
- BANDWIDTH: 500kHz
- QUIESCENT CURRENT: 1.8mA
- PACKAGES: SO-14, TSSOP-14, MSOP-10

APPLICATIONS

- NOTEBOOK COMPUTERS
- CELL PHONES
- TELECOM EQUIPMENT
- AUTOMOTIVE
- POWER MANAGEMENT
- BATTERY CHARGERS
- WELDING EQUIPMENT

DESCRIPTION

The INA203, INA204, and INA205 are a family of unidirectional, current-shunt monitors with voltage output, dual comparators, and voltage reference. The INA203, INA204, and INA205 can sense drops across shunts at common-mode voltages from -16V to $+80\text{V}$. The INA203, INA204, and INA205 are available with three output voltage scales: 20V/V, 50V/V, and 100V/V, with up to 500kHz bandwidth.

The INA203, INA204, and INA205 also incorporate two open-drain comparators with internal 0.6V references. On 14-pin versions, the comparator references can be overridden by external inputs. Comparator 1 includes a latching capability, and Comparator 2 has a user-programmable delay. 14-pin versions also provide a 1.2V reference output.

The INA203, INA204, and INA205 operate from a single $+2.7\text{V}$ to $+18\text{V}$ supply. They are specified over the extended operating temperature range of -40°C to $+125^\circ\text{C}$.

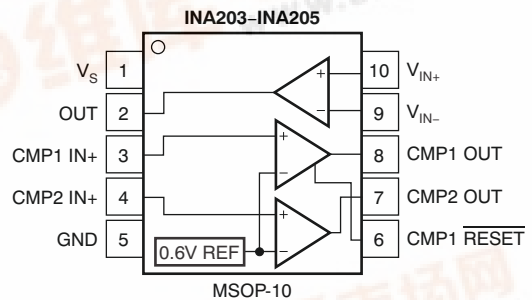
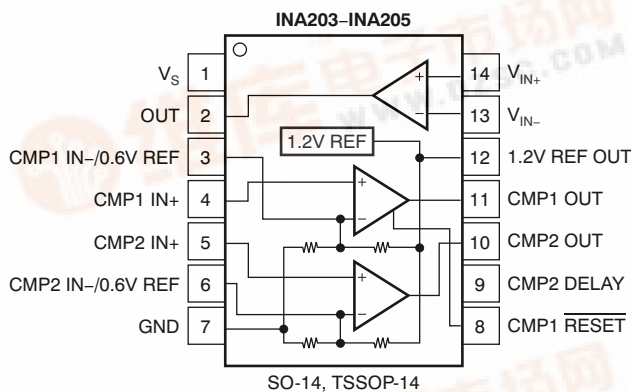

DEVICE	GAIN
INA203	20V/V
INA204	50V/V
INA205	100V/V

RELATED PRODUCTS

FEATURES	PRODUCT
Variant of INA203–INA205 Comparator 2 polarity	INA206–INA208
Current-shunt monitor with single Comparator and V_{REF}	INA200–INA202
Current-shunt monitor only	INA193–INA198
Current-shunt monitor with split stages for filter options	INA270–INA271



This integrated circuit can be damaged by ESD. Texas Instruments recommends that all integrated circuits be handled with appropriate precautions. Failure to observe proper handling and installation procedures can cause damage.

ESD damage can range from subtle performance degradation to complete device failure. Precision integrated circuits may be more susceptible to damage because very small parametric changes could cause the device not to meet its published specifications.

ORDERING INFORMATION⁽¹⁾

PRODUCT	GAIN	PACKAGE-LEAD	PACKAGE DESIGNATOR	PACKAGE MARKING	1.2V REF OUT	EXTERNAL COMP1 AND COMP2 REF INPUTS	INTERNAL COMP1 AND COMP2 0.6V REF	COMP2 DELAY PIN
INA203	20V/V	SO-14 ⁽²⁾	D	INA203A	X	X	X	X
		MSOP-10	DGS	BQN			X	
		TSSOP-14 ⁽²⁾	PW	INA203A	X	X	X	X
INA204	50V/V	SO-14 ⁽²⁾	D	INA204A	X	X	X	X
		MSOP-10	DGS	BQO			X	
		TSSOP-14 ⁽²⁾	PW	INA204A	X	X	X	X
INA205	100V/V	SO-14 ⁽²⁾	D	INA205A	X	X	X	X
		MSOP-10	DGS	BQP			X	
		TSSOP-14 ⁽²⁾	PW	INA205A	X	X	X	X

(1) For the most current package and ordering information see the Package Option Addendum at the end of this document, or see the TI web site at www.ti.com.

(2) Available Q3, 2007.

ABSOLUTE MAXIMUM RATINGS⁽¹⁾

	VALUE	UNIT
Supply Voltage, V+	18	V
Current-Shunt Monitor Analog Inputs, V _{IN+} and V _{IN-} :		
Differential (V _{IN+}) – (V _{IN-})	–18 to +18	V
Common-Mode	–16 to +80	V
Comparator Analog Input and Reset Pins	GND – 0.3 to (V+) + 0.3	V
Analog Output, Out Pin	GND – 0.3 to (V+) + 0.3	V
Comparator Output, Out Pin	GND – 0.3 to 18	V
V _{REF} and CMP2 Delay Pin	GND – 0.3 to 10	V
Input Current Into Any Pin	5	mA
Operating Temperature	–55 to +150	°C
Storage Temperature	–65 to +150	°C
Junction Temperature	+150	°C
ESD Ratings:		
Human Body Model (HBM)	4000	V
Charged Device Model (CDM)	1000	V

(1) Stresses above these ratings may cause permanent damage. Exposure to absolute maximum conditions for extended periods may degrade device reliability. These are stress ratings only, and functional operation of the device at these or any other conditions beyond those specified is not supported.

ELECTRICAL CHARACTERISTICS: CURRENT-SHUNT MONITOR

Boldface limits apply over the specified temperature range: $T_A = -40^\circ\text{C}$ to $+125^\circ\text{C}$.

At $T_A = +25^\circ\text{C}$, $V_S = +12\text{V}$, $V_{CM} = +12\text{V}$, $V_{SENSE} = 100\text{mV}$, $R_L = 10\text{k}\Omega$ to GND, $R_{PULL-UP} = 5.1\text{k}\Omega$ each connected from CMP1 OUT and CMP2 OUT to V_S , and CMP1 IN+ = 1V and CMP2 IN- = GND, unless otherwise noted.

CURRENT-SHUNT MONITOR PARAMETERS	CONDITIONS	INA203, INA204, INA205			UNIT
		MIN	TYP	MAX	
INPUT					
Full-Scale Sense Input Voltage	V_{SENSE}	$V_{SENSE} = V_{IN+} - V_{IN-}$	0.15	$(V_S - 0.25)/\text{Gain}$	V
Common-Mode Input Range	V_{CM}		-16	80	V
Common-Mode Rejection Ratio	CMRR	$V_{CM} = -16\text{V}$ to $+80\text{V}$	80	100	dB
Over Temperature		$V_{CM} = +12\text{V}$ to $+80\text{V}$	100	123	dB
Offset Voltage, RTI ⁽¹⁾	V_{OS}		± 0.5	± 2.5	mV
+25°C to +125°C				± 3	mV
-40°C to +25°C				± 3.5	mV
vs Temperature	dV_{OS}/dT	T_{MIN} to T_{MAX}	5		$\mu\text{V}/^\circ\text{C}$
vs Power Supply	PSR	$V_{OUT} = 2\text{V}$, $V_{CM} = +18\text{V}$, 2.7V	2.5	100	$\mu\text{V}/\text{V}$
Input Bias Current, V_{IN-} Pin	I_B		± 9	± 16	μA
OUTPUT ($V_{SENSE} \geq 20\text{mV}$)					
Gain:	G				
INA203			20		V/V
INA204			50		V/V
INA205			100		V/V
Gain Error		$V_{SENSE} = 20\text{mV}$ to 100mV	± 0.2	± 1	%
Over Temperature		$V_{SENSE} = 20\text{mV}$ to 100mV		± 2	%
Total Output Error ⁽²⁾		$V_{SENSE} = 120\text{mV}$, $V_S = +16\text{V}$	± 0.75	± 2.2	%
Over Temperature		$V_{SENSE} = 120\text{mV}$, $V_S = +16\text{V}$		± 3.5	%
Nonlinearity Error ⁽³⁾		$V_{SENSE} = 20\text{mV}$ to 100mV	± 0.002		%
Output Impedance, Pin 2	R_O		1.5		Ω
Maximum Capacitive Load		No Sustained Oscillation	10		nF
OUTPUT ($V_{SENSE} < 20\text{mV}$)⁽⁴⁾					
INA203, INA204, INA205		$-16\text{V} \leq V_{CM} < 0\text{V}$	300		mV
INA203		$0\text{V} \leq V_{CM} \leq V_S$, $V_S = 5\text{V}$		0.4	V
INA204		$0\text{V} \leq V_{CM} \leq V_S$, $V_S = 5\text{V}$		1	V
INA205		$0\text{V} \leq V_{CM} \leq V_S$, $V_S = 5\text{V}$		2	V
INA203, INA204, INA205		$V_S < V_{CM} \leq 80\text{V}$	300		mV
VOLTAGE OUTPUT⁽⁵⁾					
Output Swing to the Positive Rail		$V_{IN-} = 11\text{V}$, $V_{IN+} = 12\text{V}$	$(V_+) - 0.15$	$(V_+) - 0.25$	V
Output Swing to GND ⁽⁶⁾		$V_{IN-} = 0\text{V}$, $V_{IN+} = -0.5\text{V}$	$(V_{GND}) + 0.004$	$(V_{GND}) + 0.05$	V
FREQUENCY RESPONSE					
Bandwidth:	BW				
INA203		$C_{LOAD} = 5\text{pF}$	500		kHz
INA204		$C_{LOAD} = 5\text{pF}$	300		kHz
INA205		$C_{LOAD} = 5\text{pF}$	200		kHz
Phase Margin		$C_{LOAD} < 10\text{nF}$	40		Degrees
Slew Rate	SR		1		V/ μs
Settling Time (1%)		$V_{SENSE} = 10\text{mV}_{PP}$ to 100mV_{PP} , $C_{LOAD} = 5\text{pF}$	2		μs
NOISE, RTI					
Output Voltage Noise Density			40		nV/ $\sqrt{\text{Hz}}$

(1) Offset is extrapolated from measurements of the output at 20mV and 100mV V_{SENSE} .

(2) Total output error includes effects of gain error and V_{OS} .

(3) Linearity is best fit to a straight line.

(4) For details on this region of operation, see the [Accuracy Variations](#) section in the [Applications Information](#).

(5) See Typical Characteristic curve *Positive Output Voltage Swing vs Output Current* (Figure 8).

(6) Specified by design; not production tested.

ELECTRICAL CHARACTERISTICS: COMPARATOR

Boldface limits apply over the specified temperature range: $T_A = -40^{\circ}\text{C}$ to $+125^{\circ}\text{C}$.

At $T_A = +25^{\circ}\text{C}$, $V_S = +12\text{V}$, $V_{\text{CM}} = +12\text{V}$, $V_{\text{SENSE}} = 100\text{mV}$, $R_L = 10\text{k}\Omega$ to GND, and $R_{\text{PULL-UP}} = 5.1\text{k}\Omega$ each connected from CMP1 OUT and CMP2 OUT to V_S , unless otherwise noted.

COMPARATOR PARAMETERS	CONDITIONS	INA203, INA204, INA205			UNIT
		MIN	TYP	MAX	
OFFSET VOLTAGE					
Offset Voltage	Comparator Common-Mode Voltage = Threshold Voltage		2		mV
Offset Voltage Drift, Comparator 1			± 2		$\mu\text{V}/^{\circ}\text{C}$
Offset Voltage Drift, Comparator 2			+5.4		$\mu\text{V}/^{\circ}\text{C}$
Threshold	$T_A = +25^{\circ}\text{C}$	590	600	610	mV
Over Temperature		586		614	mV
Hysteresis ⁽¹⁾ , CMP1	$T_A = -40^{\circ}\text{C}$ to $+85^{\circ}\text{C}$		-8		mV
Hysteresis ⁽¹⁾ , CMP2	$T_A = -40^{\circ}\text{C}$ to $+85^{\circ}\text{C}$		8		mV
INPUT BIAS CURRENT⁽²⁾					
CMP1 IN+, CMP2 IN+ vs Temperature			0.005	10	nA
				15	nA
INPUT IMPEDANCE					
Pins 3 and 6 (14-pin packages only)			10		k Ω
INPUT RANGE					
CMP1 IN+ and CMP2 IN+ Pins 3 and 6 (14-pin packages only) ⁽³⁾			0V to $V_S - 1.5\text{V}$		V
			0V to $V_S - 1.5\text{V}$		V
OUTPUT					
Large-Signal Differential Voltage Gain	CMP V_{OUT} 1V to 4V, $R_L \geq 15\text{k}\Omega$ Connected to 5V		200		V/mV
High-Level Output Current	$V_{\text{ID}} = 0.4\text{V}$, $V_{\text{OH}} = V_S$		0.0001	1	μA
Low-Level Output Voltage	$V_{\text{ID}} = -0.6\text{V}$, $I_{\text{OL}} = 2.35\text{mA}$		220	300	mV
RESPONSE TIME⁽⁴⁾					
Comparator 1	R_L to 5V, $C_L = 15\text{pF}$, 100mV Input Step with 5mV Overdrive		1.3		μs
Comparator 2	R_L to 5V, $C_L = 15\text{pF}$, 100mV Input Step with 5mV Overdrive, C_{DELAY} Pin Open		1.3		μs
RESET					
RESET Threshold ⁽⁵⁾			1.1		V
Logic Input Impedance			2		M Ω
Minimum RESET Pulse Width			1.5		μs
RESET Propagation Delay			3		μs
Comparator 2 Delay Equation ⁽⁶⁾			$C_{\text{DELAY}} = t_{\text{D}}/5$		μF
Comparator 2 Delay t_{D}	$C_{\text{DELAY}} = 0.1\mu\text{F}$		0.5		s

- (1) Hysteresis refers to the threshold (the threshold specification applies to a rising edge of a noninverting input) of a falling edge on the noninverting input of the comparator; refer to [Figure 1](#).
- (2) Specified by design; not production tested.
- (3) See the [Comparator Maximum Input Voltage Range](#) section in the [Applications Information](#).
- (4) The comparator response time specified is the interval between the input step function and the instant when the output crosses 1.4V.
- (5) The CMP1 $\overline{\text{RESET}}$ input has an internal 2M Ω (typical) pull-down. Leaving the CMP1 $\overline{\text{RESET}}$ open results in a LOW state, with transparent comparator operation.
- (6) The Comparator 2 delay applies to both rising and falling edges of the comparator output.

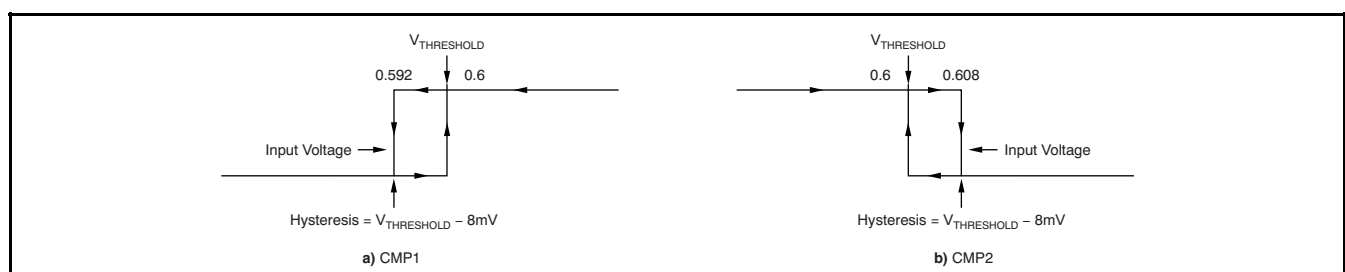

Figure 1. Comparator Hysteresis

ELECTRICAL CHARACTERISTICS: REFERENCE

Boldface limits apply over the specified temperature range: $T_A = -40^{\circ}\text{C}$ to $+125^{\circ}\text{C}$.

At $T_A = +25^{\circ}\text{C}$, $V_S = +12\text{V}$, $V_{\text{CM}} = +12\text{V}$, $V_{\text{SENSE}} = 100\text{mV}$, $R_L = 10\text{k}\Omega$ to GND, and $R_{\text{PULL-UP}} = 5.1\text{k}\Omega$ each connected from CMP1 OUT and CMP2 OUT to V_S , unless otherwise noted.

REFERENCE PARAMETERS	CONDITIONS	INA203, INA204, INA205			UNIT
		MIN	TYP	MAX	
REFERENCE VOLTAGE					
1.2 V_{REFOUT} Output Voltage		1.188	1.2	1.212	V
Reference Drift	dV_{OUT}/dT $T_A = -40^{\circ}\text{C}$ to $+85^{\circ}\text{C}$		40	100	ppm/ $^{\circ}\text{C}$
0.6 V_{REF} Output Voltage (Pins 3 and 6 of 14-pin packages only)			0.6		V
Reference Drift	dV_{OUT}/dT $T_A = -40^{\circ}\text{C}$ to $+85^{\circ}\text{C}$		40	100	ppm/ $^{\circ}\text{C}$
LOAD REGULATION	$dV_{\text{OUT}}/dI_{\text{LOAD}}$				
Sourcing	$0\text{mA} < I_{\text{SOURCE}} < 0.5\text{mA}$		0.4	2	mV/mA
Sinking	$0\text{mA} < I_{\text{SINK}} < 0.5\text{mA}$		0.4		mV/mA
LOAD CURRENT	I_{LOAD}		1		mA
LINE REGULATION	dV_{OUT}/dV_S $2.7\text{V} < V_S < 18\text{V}$		30		$\mu\text{V}/\text{V}$
CAPACITIVE LOAD					
Reference Output Maximum Capacitive Load	No Sustained Oscillations		10		nF
OUTPUT IMPEDANCE					
Pins 3 and 6 of 14-Pin Packages Only			10		k Ω

ELECTRICAL CHARACTERISTICS: GENERAL

Boldface limits apply over the specified temperature range: $T_A = -40^{\circ}\text{C}$ to $+125^{\circ}\text{C}$.

All specifications at $T_A = +25^{\circ}\text{C}$, $V_S = +12\text{V}$, $V_{\text{CM}} = +12\text{V}$, $V_{\text{SENSE}} = 100\text{mV}$, $R_L = 10\text{k}\Omega$ to GND, $R_{\text{PULL-UP}} = 5.1\text{k}\Omega$ each connected from CMP1 OUT and CMP2 OUT to V_S , and CMP1 IN+ = 1V and CMP2 IN- = GND, unless otherwise noted.

GENERAL PARAMETERS	CONDITIONS	INA203, INA204, INA205			UNIT
		MIN	TYP	MAX	
POWER SUPPLY					
Operating Power Supply	V_S	+2.7		+18	V
Quiescent Current	I_Q $V_{\text{OUT}} = 2\text{V}$ $V_{\text{SENSE}} = 0\text{mV}$		1.8	2.2	mA
Over Temperature				2.8	mA
Comparator Power-On Reset Threshold ⁽¹⁾			1.5		V
TEMPERATURE					
Specified Temperature Range		-40		+125	$^{\circ}\text{C}$
Operating Temperature Range		-55		+150	$^{\circ}\text{C}$
Storage Temperature Range		-65		+150	$^{\circ}\text{C}$
Thermal Resistance	θ_{JA}				
MSOP-10 Surface-Mount			200		$^{\circ}\text{C}/\text{W}$
SO-14, TSSOP-14 Surface-Mount			150		$^{\circ}\text{C}/\text{W}$

- (1) The INA203, INA204, and INA205 are designed to power-up with the comparator in a defined reset state as long as CMP1 $\overline{\text{RESET}}$ is open or grounded. The comparator will be in reset as long as the power supply is below the voltage shown here. The comparator assumes a state based on the comparator input above this supply voltage. If CMP1 $\overline{\text{RESET}}$ is high at power-up, the comparator output comes up high and requires a reset to assume a low state, if appropriate.

TYPICAL CHARACTERISTICS

All specifications at $T_A = +25^\circ\text{C}$, $V_S = +12\text{V}$, $V_{CM} = +12\text{V}$, and $V_{SENSE} = 100\text{mV}$, unless otherwise noted.

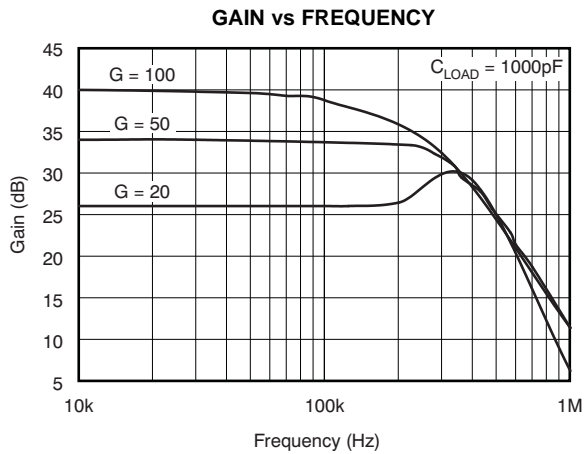

Figure 2.

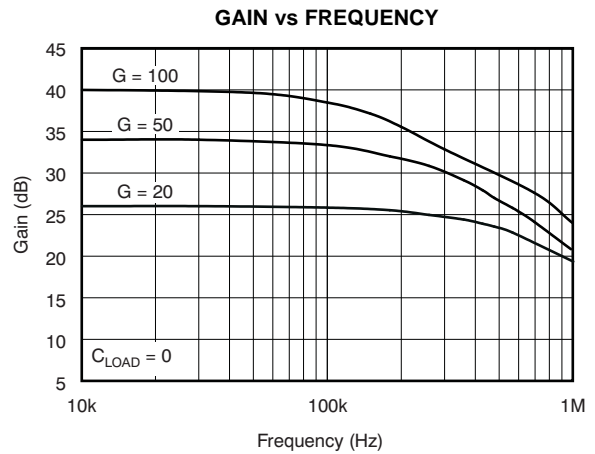

Figure 3.

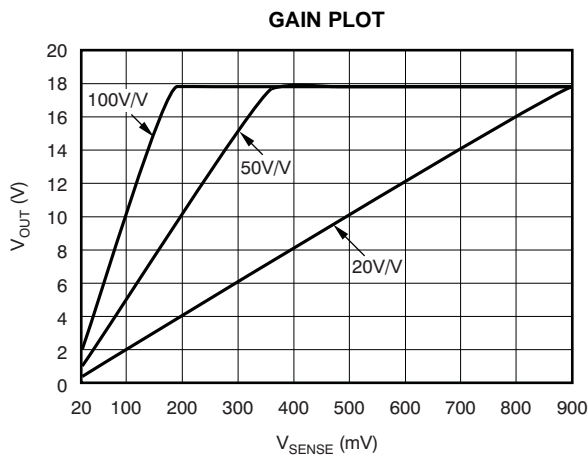

Figure 4.

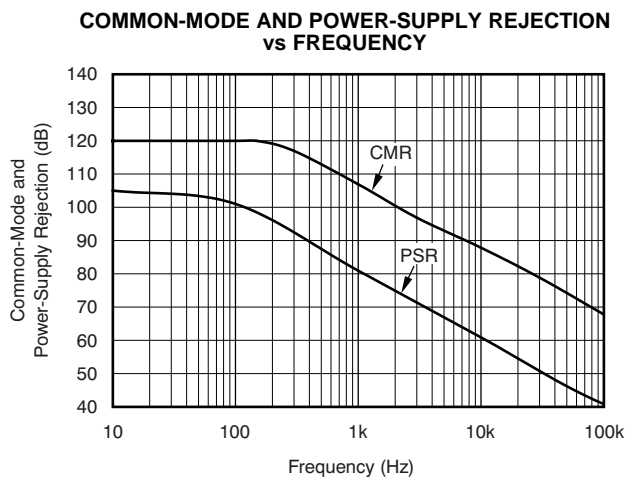

Figure 5.

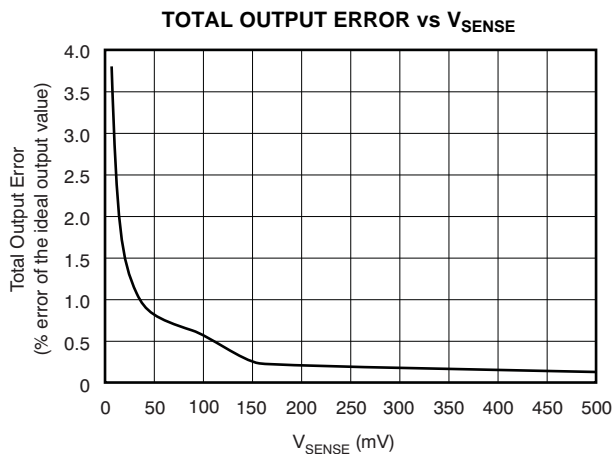

Figure 6.

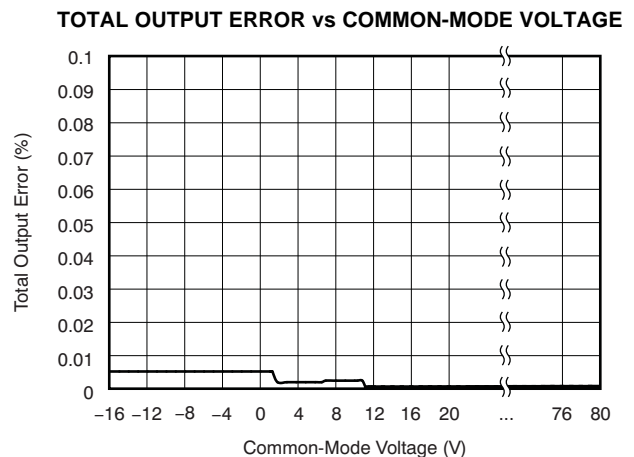

Figure 7.

TYPICAL CHARACTERISTICS (continued)

All specifications at $T_A = +25^\circ\text{C}$, $V_S = +12\text{V}$, $V_{CM} = +12\text{V}$, and $V_{SENSE} = 100\text{mV}$, unless otherwise noted.

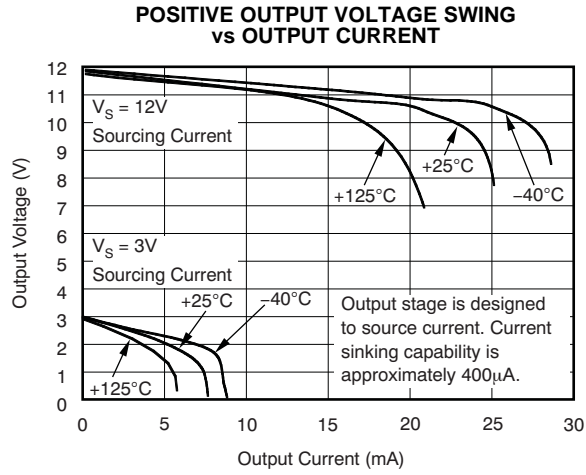

Figure 8.

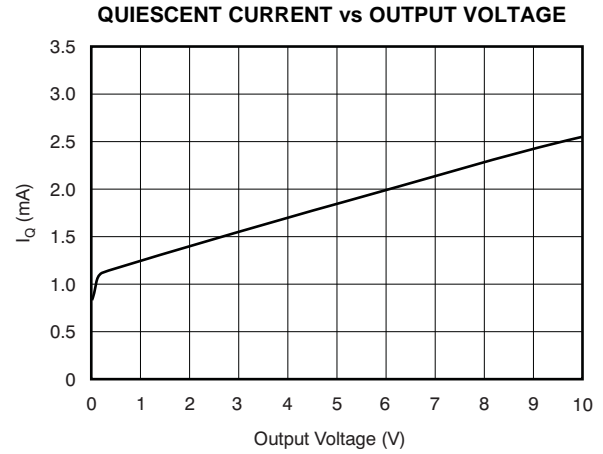

Figure 9.

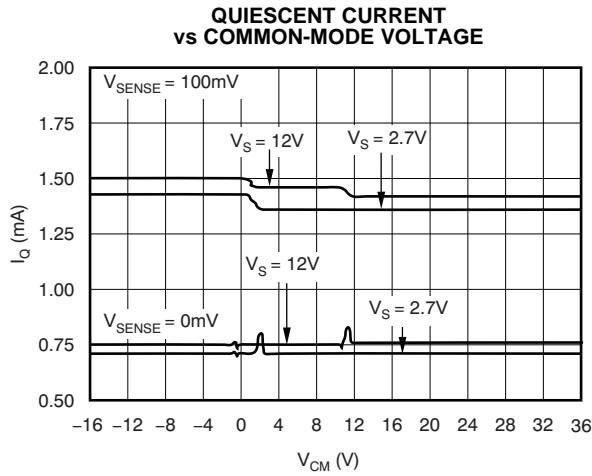

Figure 10.

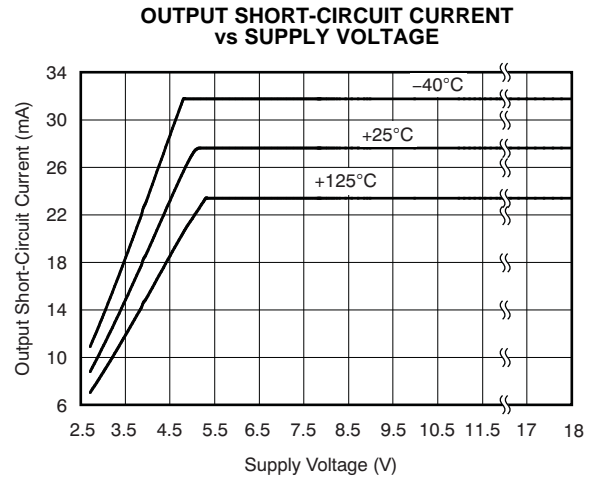

Figure 11.

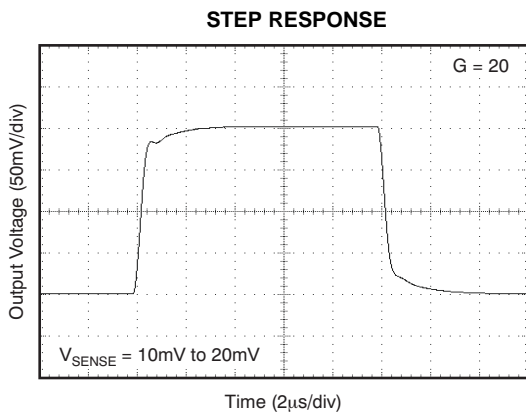

Figure 12.

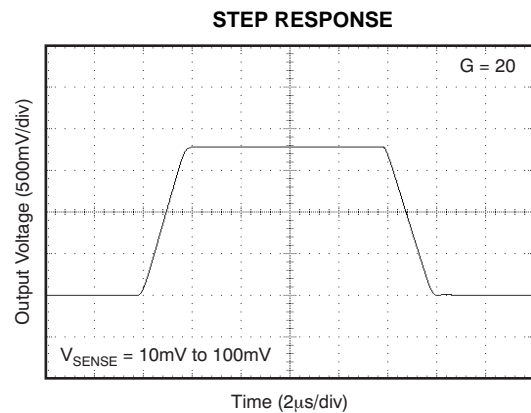

Figure 13.

TYPICAL CHARACTERISTICS (continued)

All specifications at $T_A = +25^\circ\text{C}$, $V_S = +12\text{V}$, $V_{\text{CM}} = +12\text{V}$, and $V_{\text{SENSE}} = 100\text{mV}$, unless otherwise noted.

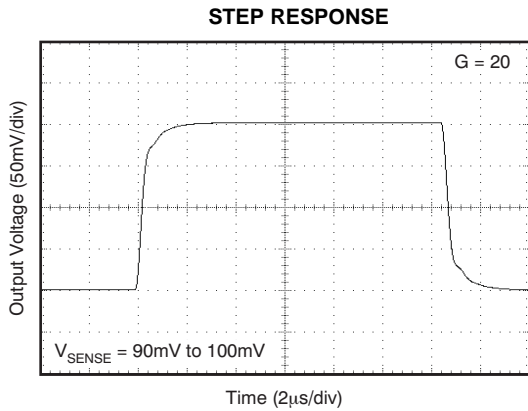

Figure 14.

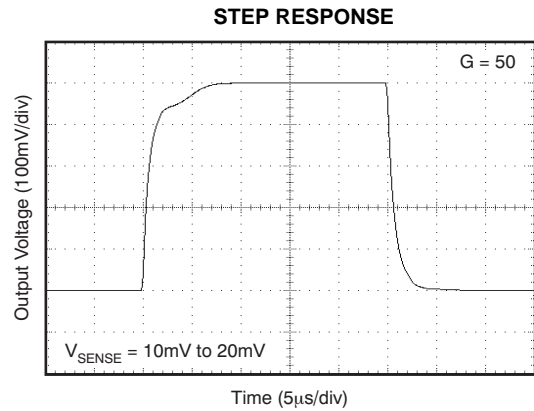

Figure 15.

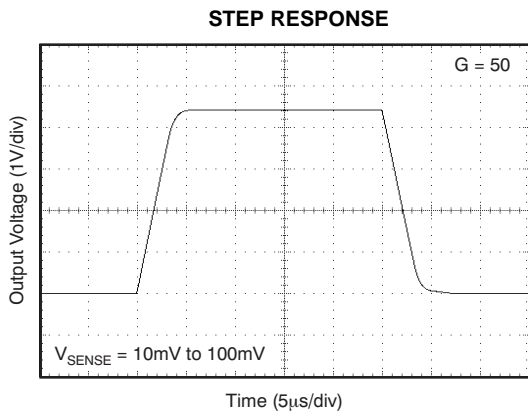

Figure 16.

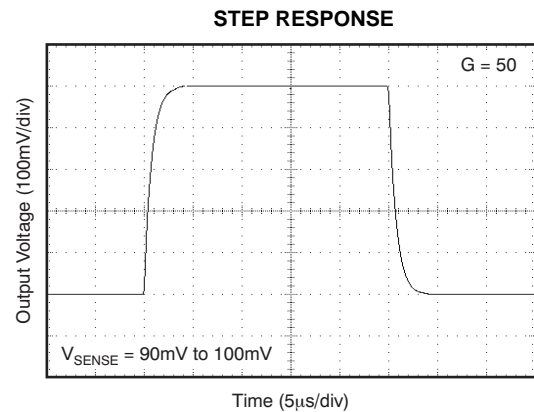

Figure 17.

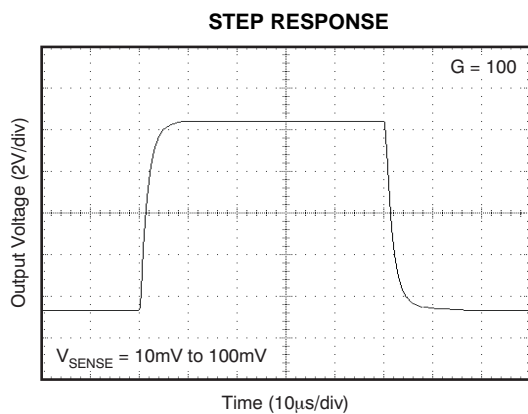

Figure 18.

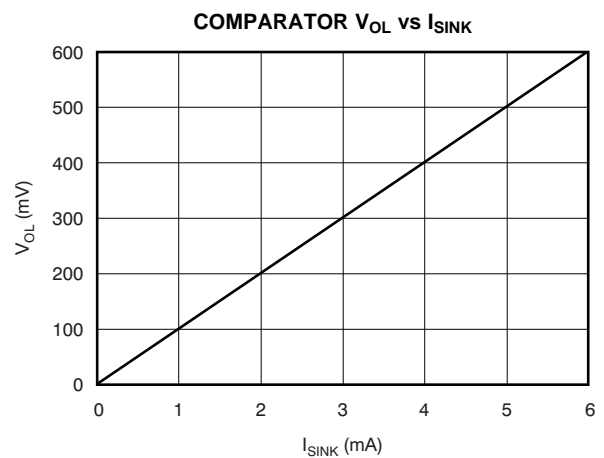

Figure 19.

TYPICAL CHARACTERISTICS (continued)

All specifications at $T_A = +25^\circ\text{C}$, $V_S = +12\text{V}$, $V_{\text{CM}} = +12\text{V}$, and $V_{\text{SENSE}} = 100\text{mV}$, unless otherwise noted.

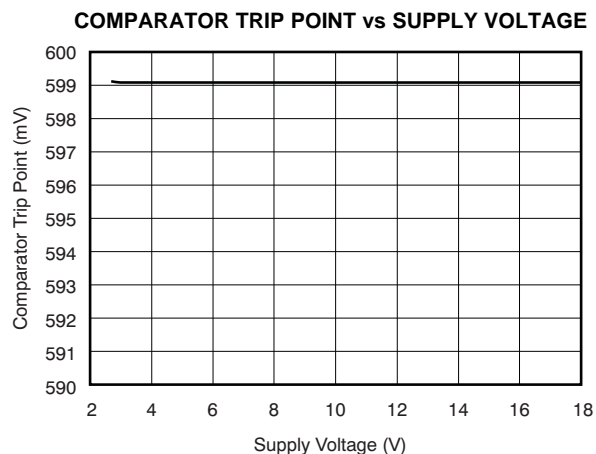

Figure 20.

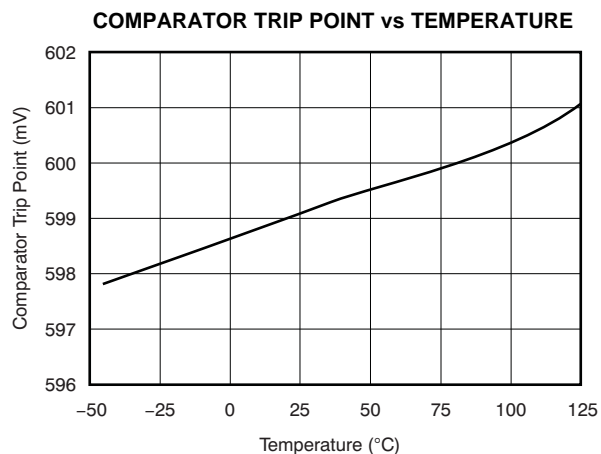

Figure 21.

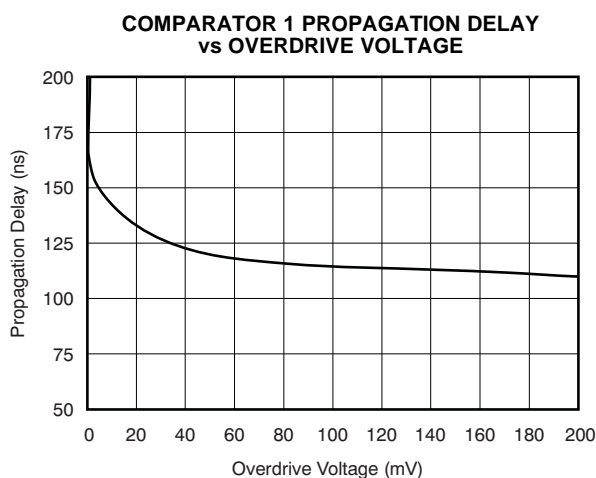

Figure 22.

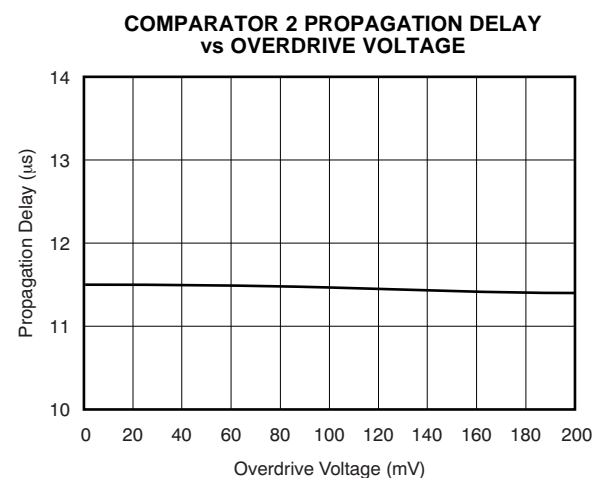

Figure 23.

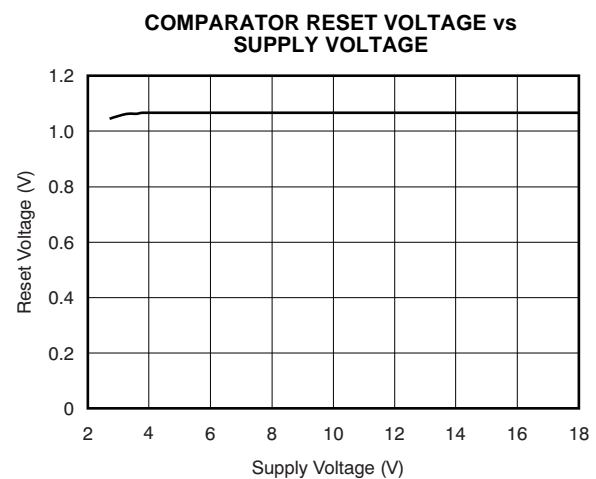

Figure 24.

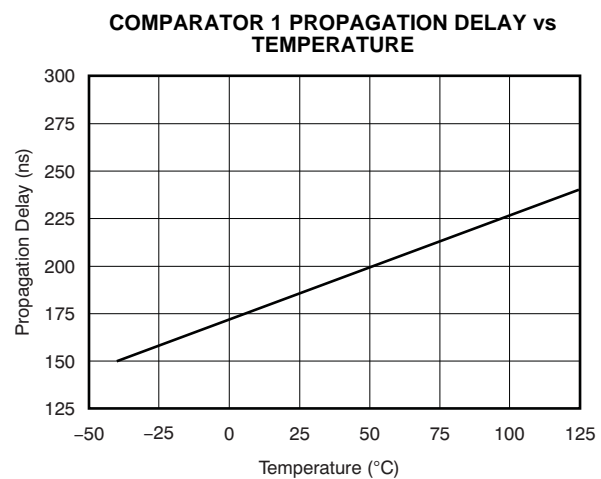

Figure 25.

TYPICAL CHARACTERISTICS (continued)

All specifications at $T_A = +25^\circ\text{C}$, $V_S = +12\text{V}$, $V_{CM} = +12\text{V}$, and $V_{SENSE} = 100\text{mV}$, unless otherwise noted.

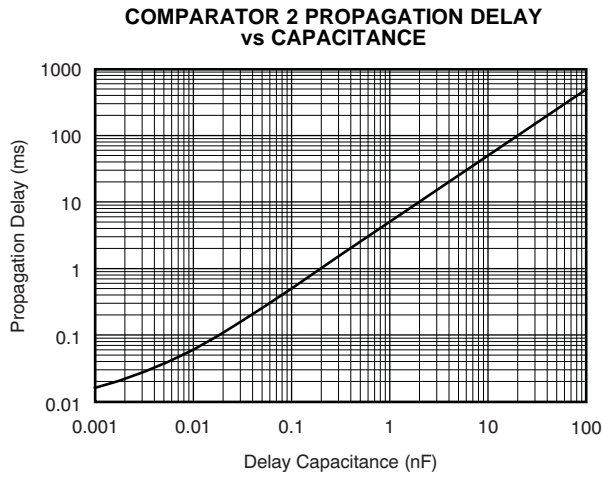

Figure 26.

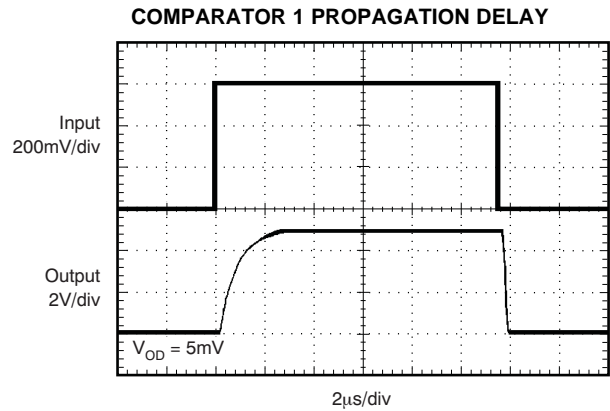

Figure 27.

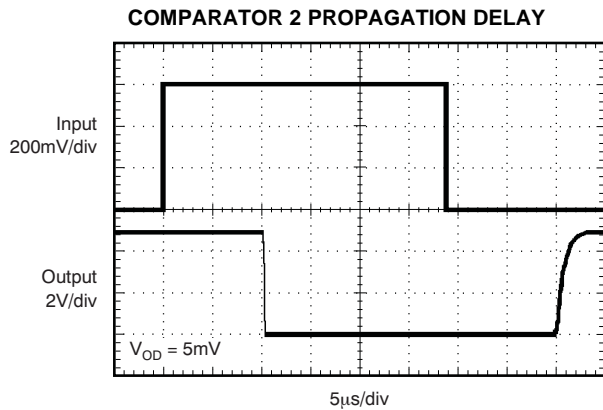

Figure 28.

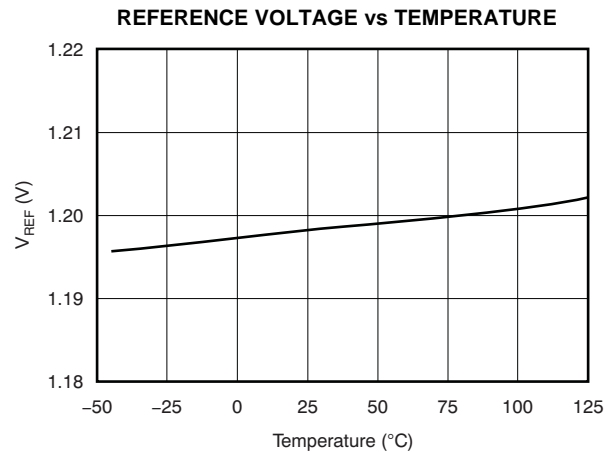

Figure 29.

APPLICATIONS INFORMATION

BASIC CONNECTIONS

Figure 30 shows the basic connections of the INA203, INA204, and INA205. The input pins, V_{IN+} and V_{IN-} , should be connected as closely as possible to the shunt resistor to minimize any resistance in series with the shunt resistance.

Power-supply bypass capacitors are required for stability. Applications with noisy or high-impedance power supplies may require additional decoupling capacitors to reject power-supply noise. Connect bypass capacitors close to the device pins.

POWER SUPPLY

The input circuitry of the INA203, INA204, and INA205 can accurately measure beyond the power-supply voltage, $V+$. For example, the $V+$ power supply can be 5V, whereas the load power-supply voltage is up to +80V. The output voltage range of the OUT terminal, however, is limited by the voltages on the power-supply pin.

ACCURACY VARIATIONS AS A RESULT OF V_{SENSE} AND COMMON-MODE VOLTAGE

The accuracy of the INA203, INA204, and INA205 current shunt monitors is a function of two main variables: V_{SENSE} ($V_{IN+} - V_{IN-}$) and common-mode voltage, V_{CM} , relative to the supply voltage, V_S . V_{CM} is expressed as $(V_{IN+} + V_{IN-})/2$; however, in practice, V_{CM} is seen as the voltage at V_{IN+} because the voltage drop across V_{SENSE} is usually small.

This section addresses the accuracy of these specific operating regions:

- Normal Case 1: $V_{SENSE} \geq 20\text{mV}$, $V_{CM} \geq V_S$
- Normal Case 2: $V_{SENSE} \geq 20\text{mV}$, $V_{CM} < V_S$
- Low V_{SENSE} Case 1: $V_{SENSE} < 20\text{mV}$, $-16\text{V} \leq V_{CM} < 0$
- Low V_{SENSE} Case 2: $V_{SENSE} < 20\text{mV}$, $0\text{V} \leq V_{CM} \leq V_S$
- Low V_{SENSE} Case 3: $V_{SENSE} < 20\text{mV}$, $V_S < V_{CM} \leq 80\text{V}$

Normal Case 1: $V_{SENSE} \geq 20\text{mV}$, $V_{CM} \geq V_S$

This region of operation provides the highest accuracy. Here, the input offset voltage is characterized and measured using a two-step method. First, the gain is determined by Equation 1.

$$G = \frac{V_{OUT1} - V_{OUT2}}{100\text{mV} - 20\text{mV}} \quad (1)$$

where:

V_{OUT1} = Output Voltage with $V_{SENSE} = 100\text{mV}$

V_{OUT2} = Output Voltage with $V_{SENSE} = 20\text{mV}$

Then the offset voltage is measured at $V_{SENSE} = 100\text{mV}$ and referred to the input (RTI) of the current shunt monitor, as shown in Equation 2.

$$V_{OS\text{RTI}} (\text{Referred-To-Input}) = \left[\frac{V_{OUT1}}{G} \right] - 100\text{mV} \quad (2)$$

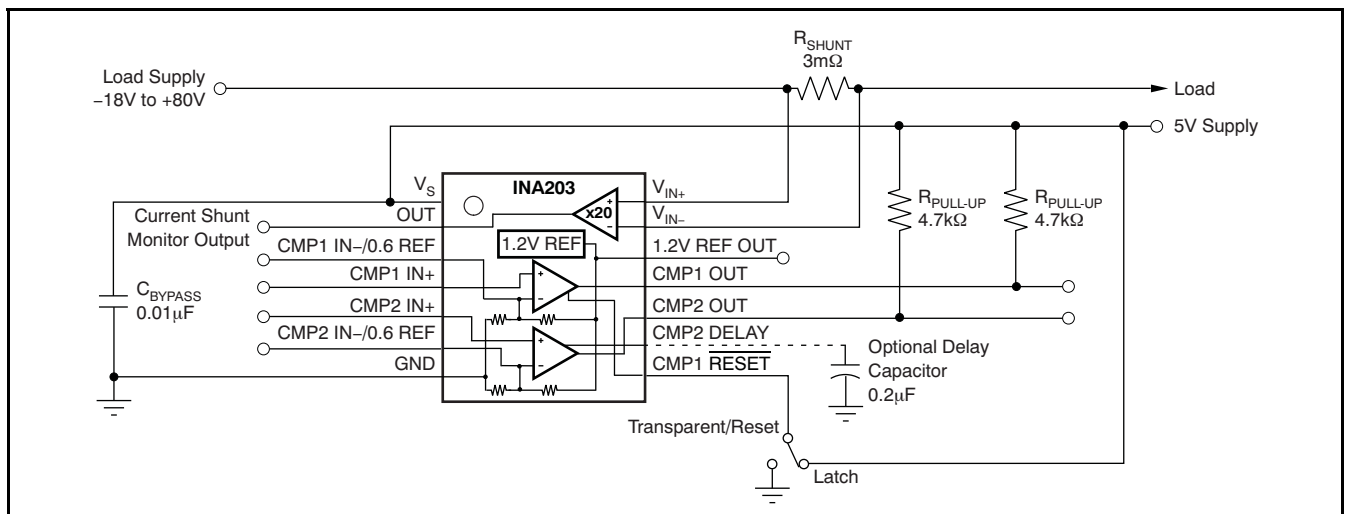

Figure 30. INA20x Basic Connection

In the [Typical Characteristics](#), the *Output Error vs Common-Mode Voltage* curve ([Figure 7](#)) shows the highest accuracy for this region of operation. In this plot, $V_S = 12V$; for $V_{CM} \geq 12V$, the output error is at its minimum. This case is also used to create the $V_{SENSE} \geq 20mV$ output specifications in the [Electrical Characteristics](#) table.

Normal Case 2: $V_{SENSE} \geq 20mV, V_{CM} < V_S$

This region of operation has slightly less accuracy than Normal Case 1 as a result of the common-mode operating area in which the part functions, as seen in the *Output Error vs Common-Mode Voltage* curve ([Figure 7](#)). As noted, for this graph $V_S = 12V$; for $V_{CM} < 12V$, the Output Error increases as V_{CM} becomes less than 12V, with a typical maximum error of 0.005% at the most negative $V_{CM} = -16V$.

Low V_{SENSE} Case 1:

$V_{SENSE} < 20mV, -16V \leq V_{CM} < 0$; and
Low V_{SENSE} Case 3:
 $V_{SENSE} < 20mV, V_S < V_{CM} \leq 80V$

Although the INA203 family of devices are not designed for accurate operation in either of these regions, some applications are exposed to these conditions; for example, when monitoring power supplies that are switched on and off while V_S is still applied to the INA203, INA204, or INA205. It is important to know what the behavior of the devices will be in these regions.

As V_{SENSE} approaches 0mV, in these V_{CM} regions, the device output accuracy degrades. A larger-than-normal offset can appear at the current shunt monitor output with a typical maximum value of $V_{OUT} = 300mV$ for $V_{SENSE} = 0mV$. As V_{SENSE} approaches 20mV, V_{OUT} returns to the expected output value with accuracy as specified in the [Electrical Characteristics](#). [Figure 31](#) illustrates this effect using the INA205 (Gain = 100).

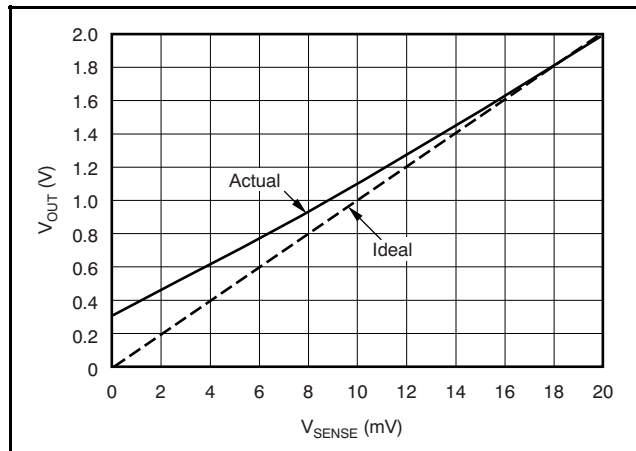

Figure 31. Example for Low V_{SENSE} Cases 1 and 3 (INA205, Gain = 100)

Low V_{SENSE} Case 2: $V_{SENSE} < 20mV, 0V \leq V_{CM} \leq V_S$

This region of operation is the least accurate for the INA203 family. To achieve the wide input common-mode voltage range, these devices use two op amp front ends in parallel. One op amp front end operates in the positive input common-mode voltage range, and the other in the negative input region. For this case, neither of these two internal amplifiers dominates and overall loop gain is very low. Within this region, V_{OUT} approaches voltages close to linear operation levels for Normal Case 2. This deviation from linear operation becomes greatest the closer V_{SENSE} approaches 0V. Within this region, as V_{SENSE} approaches 20mV, device operation is closer to that described by Normal Case 2. [Figure 32](#) illustrates this behavior for the INA205. The V_{OUT} maximum peak for this case is tested by maintaining a constant V_S , setting $V_{SENSE} = 0mV$, and sweeping V_{CM} from 0V to V_S . The exact V_{CM} at which V_{OUT} peaks during this test varies from part to part, but the V_{OUT} maximum peak is tested to be less than the specified V_{OUT} Tested Limit.

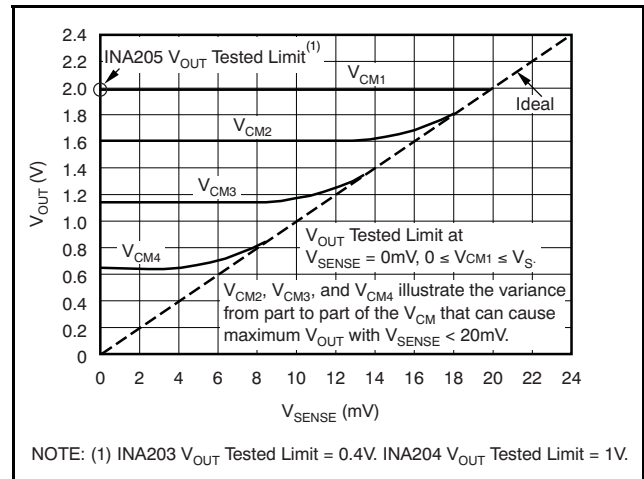

Figure 32. Example for Low V_{SENSE} Case 2 (INA205, Gain = 100)

SELECTING R_{SHUNT}

The value chosen for the shunt resistor, R_{SHUNT} , depends on the application and is a compromise between small-signal accuracy and maximum permissible voltage loss in the measurement line. High values of R_{SHUNT} provide better accuracy at lower currents by minimizing the effects of offset, while low values of R_{SHUNT} minimize voltage loss in the supply line. For most applications, best performance is attained with an R_{SHUNT} value that provides a full-scale shunt voltage range of 50mV to 100mV. Maximum input voltage for accurate measurements is $(V_{SHUNT} - 0.25)/Gain$.

TRANSIENT PROTECTION

The -16V to $+80\text{V}$ common-mode range of the INA203, INA204, and INA205 is ideal for withstanding automotive fault conditions ranging from 12V battery reversal up to $+80\text{V}$ transients, since no additional protective components are needed up to those levels. In the event that the INA203, INA204, and INA205 are exposed to transients on the inputs in excess of their ratings, then external transient absorption with semiconductor transient absorbers (zeners or *Transzorbs*) are necessary. Use of metal oxide varistors (MOVs) or video disk recorders (VDRs) is not recommended except when they are used in addition to a semiconductor transient absorber. Select the transient absorber such that it will never allow the INA203, INA204, and INA205 to be exposed to transients greater than $+80\text{V}$ (that is, allow for transient absorber tolerance, as well as additional voltage because of transient absorber dynamic impedance). Despite the use of internal zener-type ESD protection, the INA203, INA204, and INA205 do not lend themselves to using external resistors in series with the inputs because the internal gain resistors can vary up to $\pm 30\%$ but are closely matched. (If gain accuracy is not important, then resistors can be added in series with the INA203, INA204, and INA205 inputs with two equal resistors on each input.)

OUTPUT VOLTAGE RANGE

The output of the INA203, INA204, and INA205 is accurate within the output voltage swing range set by the power-supply pin, V_{+} . This performance is best

illustrated when using the INA205 (a gain of 100 version), where a 100mV full-scale input from the shunt resistor requires an output voltage swing of $+10\text{V}$, and a power-supply voltage sufficient to achieve $+10\text{V}$ on the output.

INPUT FILTERING

An obvious and straightforward location for filtering is at the output of the INA203, INA204, and INA205 series; however, this location negates the advantage of the low output impedance of the internal buffer. The only other option for filtering is at the input pins of the INA203, INA204, and INA205, which is complicated by the internal $5\text{k}\Omega + 30\%$ input impedance; this configuration is illustrated in Figure 33. Using the lowest possible resistor values minimizes both the initial shift in gain and effects of tolerance. The effect on initial gain is given by Equation 3:

$$\text{Gain Error \%} = 100 - \left[100 \times \frac{5\text{k}\Omega}{5\text{k}\Omega + R_{\text{FILT}}} \right] \quad (3)$$

Total effect on gain error can be calculated by replacing the $5\text{k}\Omega$ term with $5\text{k}\Omega - 30\%$, (or $3.5\text{k}\Omega$) or $5\text{k}\Omega + 30\%$ (or $6.5\text{k}\Omega$). The tolerance extremes of R_{FILT} can also be inserted into the equation. If a pair of 100Ω 1% resistors are used on the inputs, the initial gain error will be 1.96%. Worst-case tolerance conditions will always occur at the lower excursion of the internal $5\text{k}\Omega$ resistor ($3.5\text{k}\Omega$), and the higher excursion of $R_{\text{FILT}} - 3\%$ in this case.

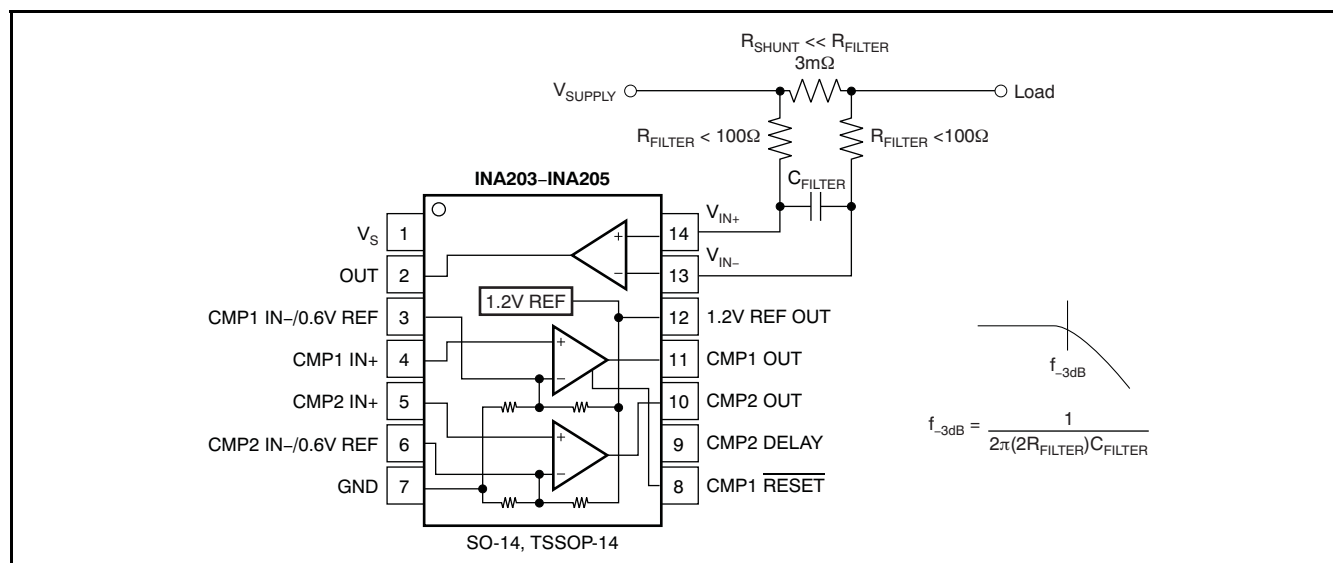

Figure 33. Input Filter (Gain Error: 1.5% to -2.2%)

Note that the specified accuracy of the INA203, INA204, and INA205 must then be combined in addition to these tolerances. While this discussion treated accuracy worst-case conditions by combining the extremes of the resistor values, it is appropriate to use geometric mean or root sum square calculations to total the effects of accuracy variations.

REFERENCE

The INA203, INA204, and INA205 include an internal voltage reference that has a load regulation of 0.4mV/mA (typical), and not more than 100ppm/°C of drift. Only the 14-pin package allows external access to reference voltages, where voltages of 1.2V and 0.6V are both available. Output current versus output voltage is illustrated in the [Typical Characteristics](#) section.

COMPARATOR

The INA203, INA204, and INA205 devices incorporate two open-drain comparators. These comparators typically have 2mV of offset and a 1.3µs (typical) response time. The output of Comparator 1 latches and is reset through the CMP1 RESET pin, as shown in [Figure 35](#). This configuration applies to both the 10- and 14-pin versions. [Figure 34](#) illustrates the comparator delay.

The 14-pin versions of the INA203, INA204, and INA205 include additional features for comparator functions. The comparator reference voltage of both Comparator 1 and Comparator 2 can be overridden by external inputs for increased design flexibility. Comparator 2 has a programmable delay.

COMPARATOR DELAY (14-Pin Version Only)

The Comparator 2 programmable delay is controlled by a capacitor connected to the CMP2 Delay Pin; see [Figure 30](#). The capacitor value (in µF) is selected by using [Equation 4](#):

$$C_{\text{DELAY}} \text{ (in } \mu\text{F)} = \frac{t_D}{5} \quad (4)$$

A simplified version of the delay circuit for Comparator 2 is shown in [Figure 34](#). The delay comparator consists of two comparator stages with the delay between them. Note that I1 and I2 cannot be turned on simultaneously; I1 corresponds to a U1 low output and I2 corresponds to a U1 high output. Using an initial assumption that the U1 output is low, I1 is on, then U2 +IN is zero. If U1 goes high, I2 supplies 120nA to C_{DELAY}. The voltage at U2 +IN begins to ramp toward a 0.6V threshold. When the voltage crosses this threshold, the U2 output goes high while the voltage at U2 +IN continues to ramp up to a maximum of 1.2V when given sufficient time (twice the value of the delay specified for C_{DELAY}). This entire sequence is reversed when the comparator outputs go low, so that returning to low exhibits the same delay.

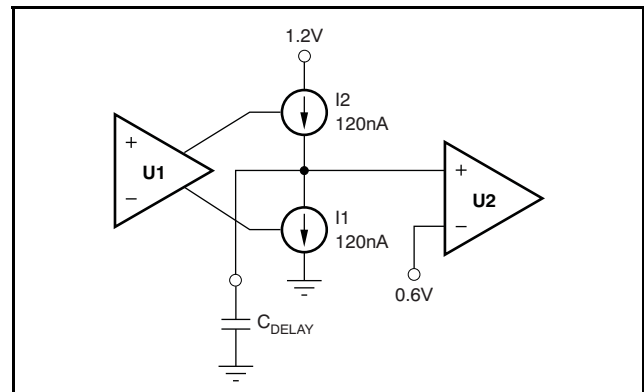

Figure 34. Simplified Model of the Comparator 2 Delay Circuit

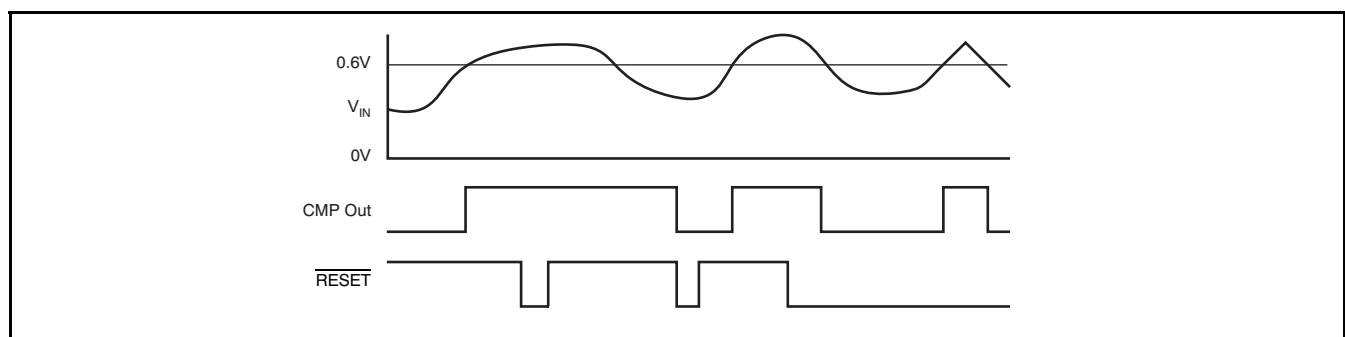

Figure 35. Comparator Latching Capability

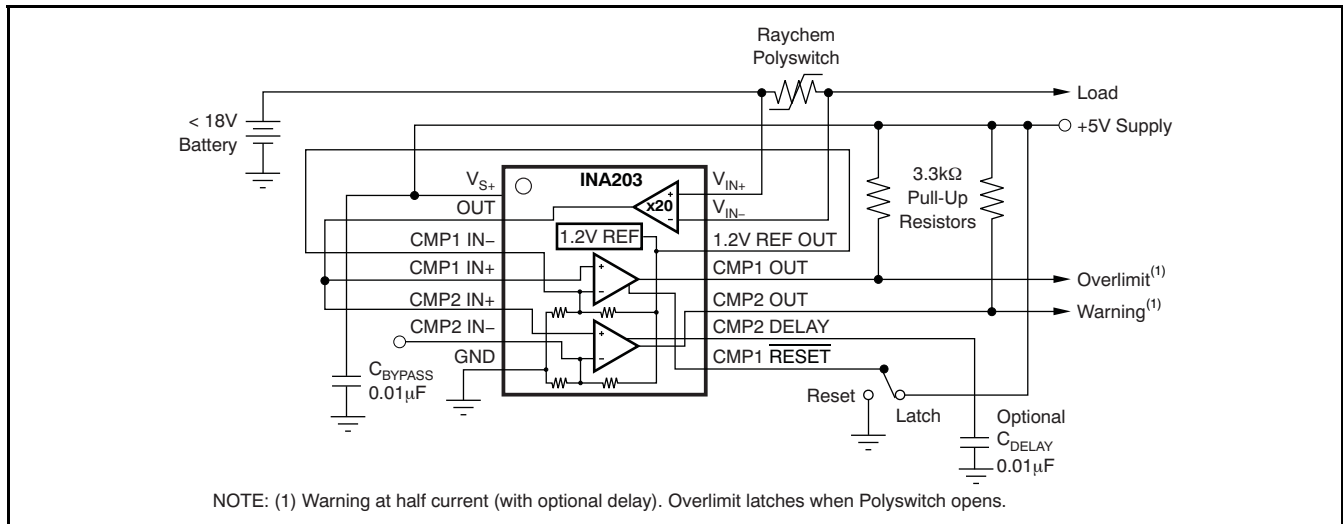

Figure 38. Polyswitch Warning and Fault Detection Circuit

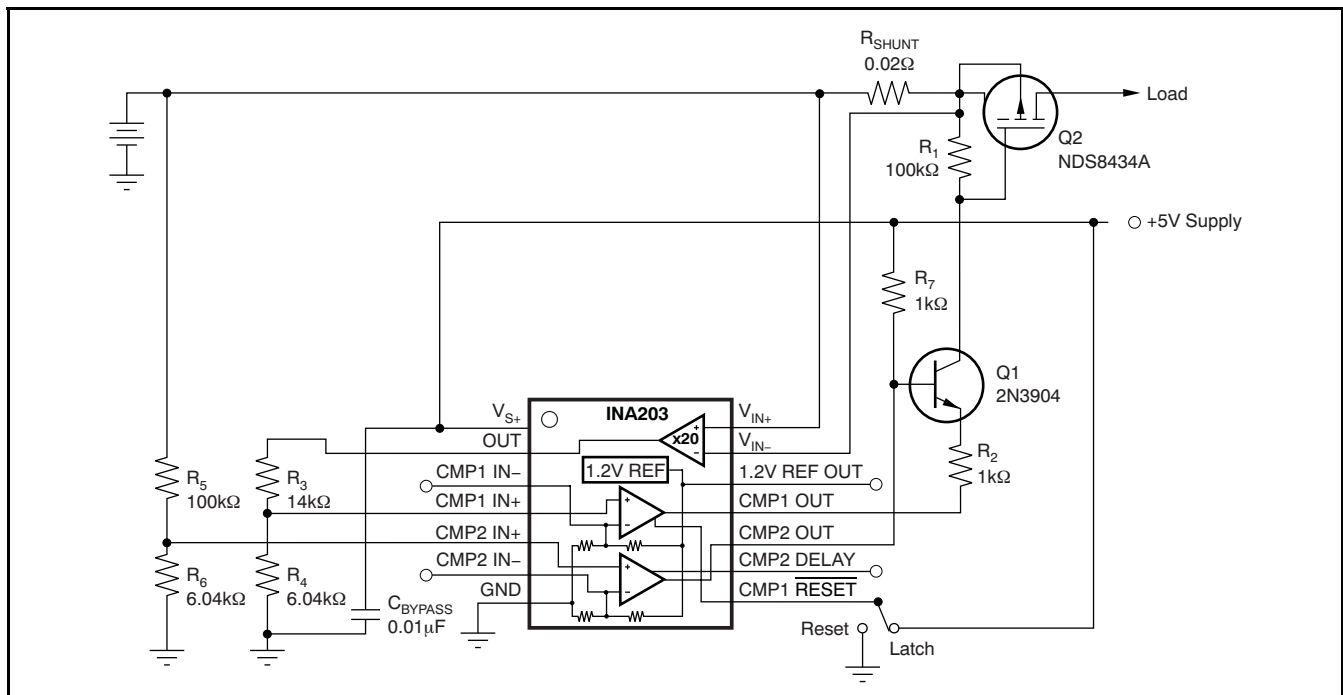

Figure 39. Lead-Acid Battery Protection Circuit

PACKAGING INFORMATION

Orderable Device	Status ⁽¹⁾	Package Type	Package Drawing	Pins	Package Qty	Eco Plan ⁽²⁾	Lead/Ball Finish	MSL Peak Temp ⁽³⁾
INA203AIDGSR	ACTIVE	MSOP	DGS	10	2500	Green (RoHS & no Sb/Br)	CU NIPDAU	Level-2-260C-1 YEAR
INA203AIDGSRG4	ACTIVE	MSOP	DGS	10	2500	Green (RoHS & no Sb/Br)	CU NIPDAU	Level-2-260C-1 YEAR
INA203AIDGST	ACTIVE	MSOP	DGS	10	250	Green (RoHS & no Sb/Br)	CU NIPDAU	Level-2-260C-1 YEAR
INA203AIDGSTG4	ACTIVE	MSOP	DGS	10	250	Green (RoHS & no Sb/Br)	CU NIPDAU	Level-2-260C-1 YEAR
INA204AIDGSR	ACTIVE	MSOP	DGS	10	2500	Green (RoHS & no Sb/Br)	CU NIPDAU	Level-2-260C-1 YEAR
INA204AIDGSRG4	ACTIVE	MSOP	DGS	10	2500	Green (RoHS & no Sb/Br)	CU NIPDAU	Level-2-260C-1 YEAR
INA204AIDGST	ACTIVE	MSOP	DGS	10	250	Green (RoHS & no Sb/Br)	CU NIPDAU	Level-2-260C-1 YEAR
INA204AIDGSTG4	ACTIVE	MSOP	DGS	10	250	Green (RoHS & no Sb/Br)	CU NIPDAU	Level-2-260C-1 YEAR
INA205AIDGSR	ACTIVE	MSOP	DGS	10	2500	Green (RoHS & no Sb/Br)	CU NIPDAU	Level-2-260C-1 YEAR
INA205AIDGSRG4	ACTIVE	MSOP	DGS	10	2500	Green (RoHS & no Sb/Br)	CU NIPDAU	Level-2-260C-1 YEAR
INA205AIDGST	ACTIVE	MSOP	DGS	10	250	Green (RoHS & no Sb/Br)	CU NIPDAU	Level-2-260C-1 YEAR
INA205AIDGSTG4	ACTIVE	MSOP	DGS	10	250	Green (RoHS & no Sb/Br)	CU NIPDAU	Level-2-260C-1 YEAR

⁽¹⁾ The marketing status values are defined as follows:

ACTIVE: Product device recommended for new designs.

LIFEBUY: TI has announced that the device will be discontinued, and a lifetime-buy period is in effect.

NRND: Not recommended for new designs. Device is in production to support existing customers, but TI does not recommend using this part in a new design.

PREVIEW: Device has been announced but is not in production. Samples may or may not be available.

OBsolete: TI has discontinued the production of the device.

⁽²⁾ Eco Plan - The planned eco-friendly classification: Pb-Free (RoHS), Pb-Free (RoHS Exempt), or Green (RoHS & no Sb/Br) - please check <http://www.ti.com/productcontent> for the latest availability information and additional product content details.

TBD: The Pb-Free/Green conversion plan has not been defined.

Pb-Free (RoHS): TI's terms "Lead-Free" or "Pb-Free" mean semiconductor products that are compatible with the current RoHS requirements for all 6 substances, including the requirement that lead not exceed 0.1% by weight in homogeneous materials. Where designed to be soldered at high temperatures, TI Pb-Free products are suitable for use in specified lead-free processes.

Pb-Free (RoHS Exempt): This component has a RoHS exemption for either 1) lead-based flip-chip solder bumps used between the die and package, or 2) lead-based die adhesive used between the die and leadframe. The component is otherwise considered Pb-Free (RoHS compatible) as defined above.

Green (RoHS & no Sb/Br): TI defines "Green" to mean Pb-Free (RoHS compatible), and free of Bromine (Br) and Antimony (Sb) based flame retardants (Br or Sb do not exceed 0.1% by weight in homogeneous material)

⁽³⁾ MSL, Peak Temp. -- The Moisture Sensitivity Level rating according to the JEDEC industry standard classifications, and peak solder temperature.

Important Information and Disclaimer: The information provided on this page represents TI's knowledge and belief as of the date that it is provided. TI bases its knowledge and belief on information provided by third parties, and makes no representation or warranty as to the accuracy of such information. Efforts are underway to better integrate information from third parties. TI has taken and continues to take reasonable steps to provide representative and accurate information but may not have conducted destructive testing or chemical analysis on incoming materials and chemicals. TI and TI suppliers consider certain information to be proprietary, and thus CAS numbers and other limited information may not be available for release.

In no event shall TI's liability arising out of such information exceed the total purchase price of the TI part(s) at issue in this document sold by TI to Customer on an annual basis.

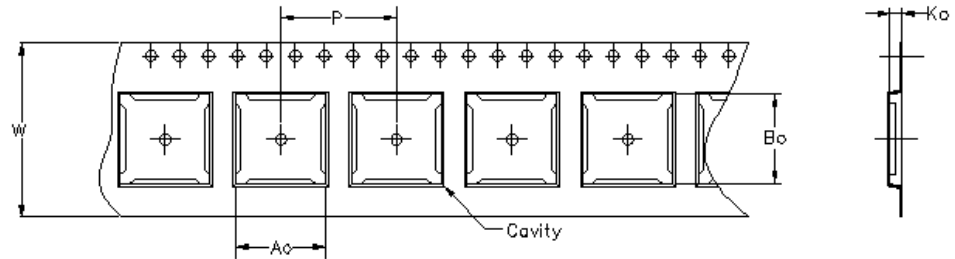

Carrier tape design is defined largely by the component length, width, and thickness.

A_0 = Dimension designed to accommodate the component width.
B_0 = Dimension designed to accommodate the component length.
K_0 = Dimension designed to accommodate the component thickness.
W = Overall width of the carrier tape.
P = Pitch between successive cavity centers.



TAPE AND REEL INFORMATION

Device	Package	Pins	Site	Reel Diameter (mm)	Reel Width (mm)	A0 (mm)	B0 (mm)	K0 (mm)	P1 (mm)	W (mm)	Pin1 Quadrant
INA203AIDGSR	DGS	10	MLA	330	12	5.3	3.4	1.4	8	12	PKGORN T1TR-MS P
INA203AIDGST	DGS	10	MLA	0	0	5.3	3.4	1.4	8	12	PKGORN T1TR-MS P
INA204AIDGSR	DGS	10	MLA	330	12	5.3	3.4	1.4	8	12	PKGORN T1TR-MS P
INA204AIDGST	DGS	10	MLA	0	0	5.3	3.4	1.4	8	12	PKGORN T1TR-MS P

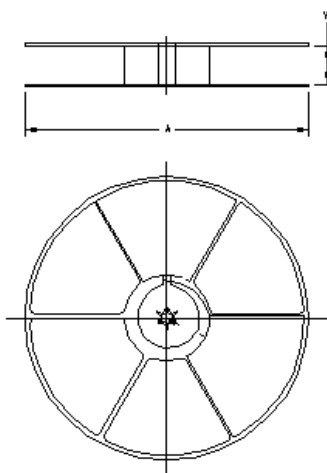

TAPE AND REEL BOX INFORMATION

Device	Package	Pins	Site	Length (mm)	Width (mm)	Height (mm)
INA203AIDGSR	DGS	10	MLA	390.0	348.0	63.0
INA203AIDGST	DGS	10	MLA	342.9	336.6	28.58
INA204AIDGSR	DGS	10	MLA	390.0	348.0	63.0
INA204AIDGST	DGS	10	MLA	342.9	336.6	28.58

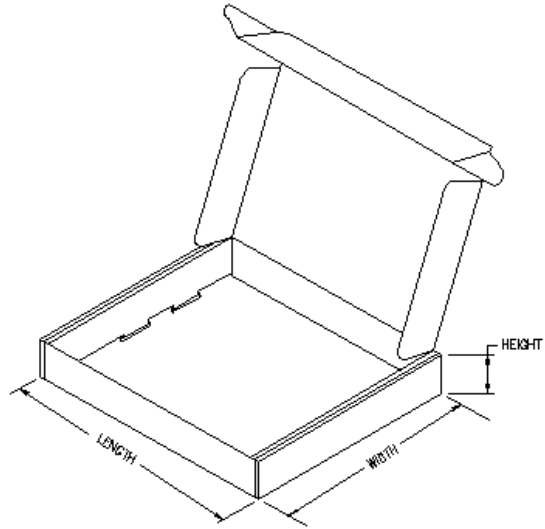

MECHANICAL DATA

DGS (S-PDSO-G10)

PLASTIC SMALL-OUTLINE PACKAGE

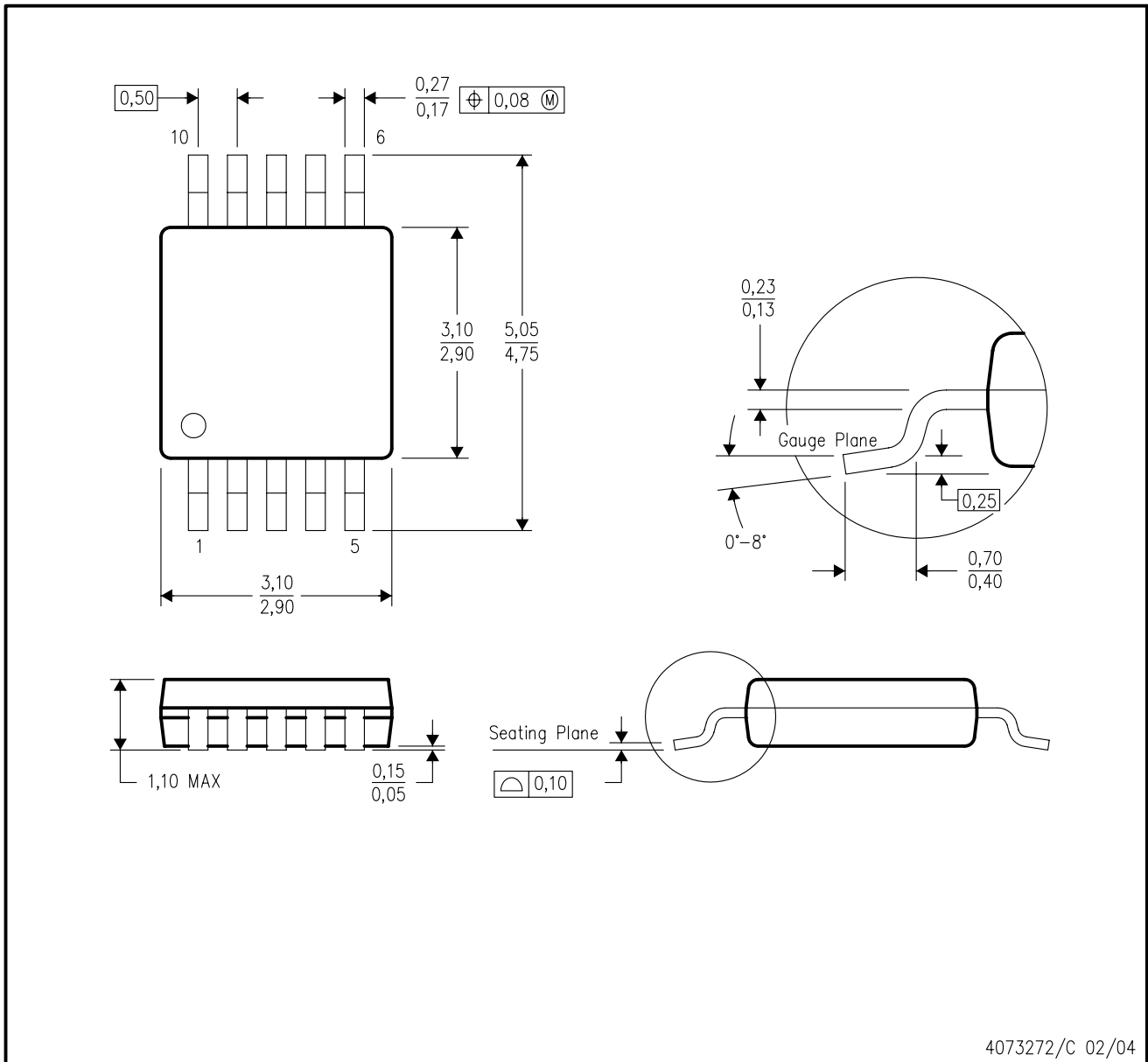

- NOTES:
- All linear dimensions are in millimeters.
 - This drawing is subject to change without notice.
 - Body dimensions do not include mold flash or protrusion.
 - Falls within JEDEC MO-187 variation BA.

D (R-PDSO-G14)

PLASTIC SMALL-OUTLINE PACKAGE

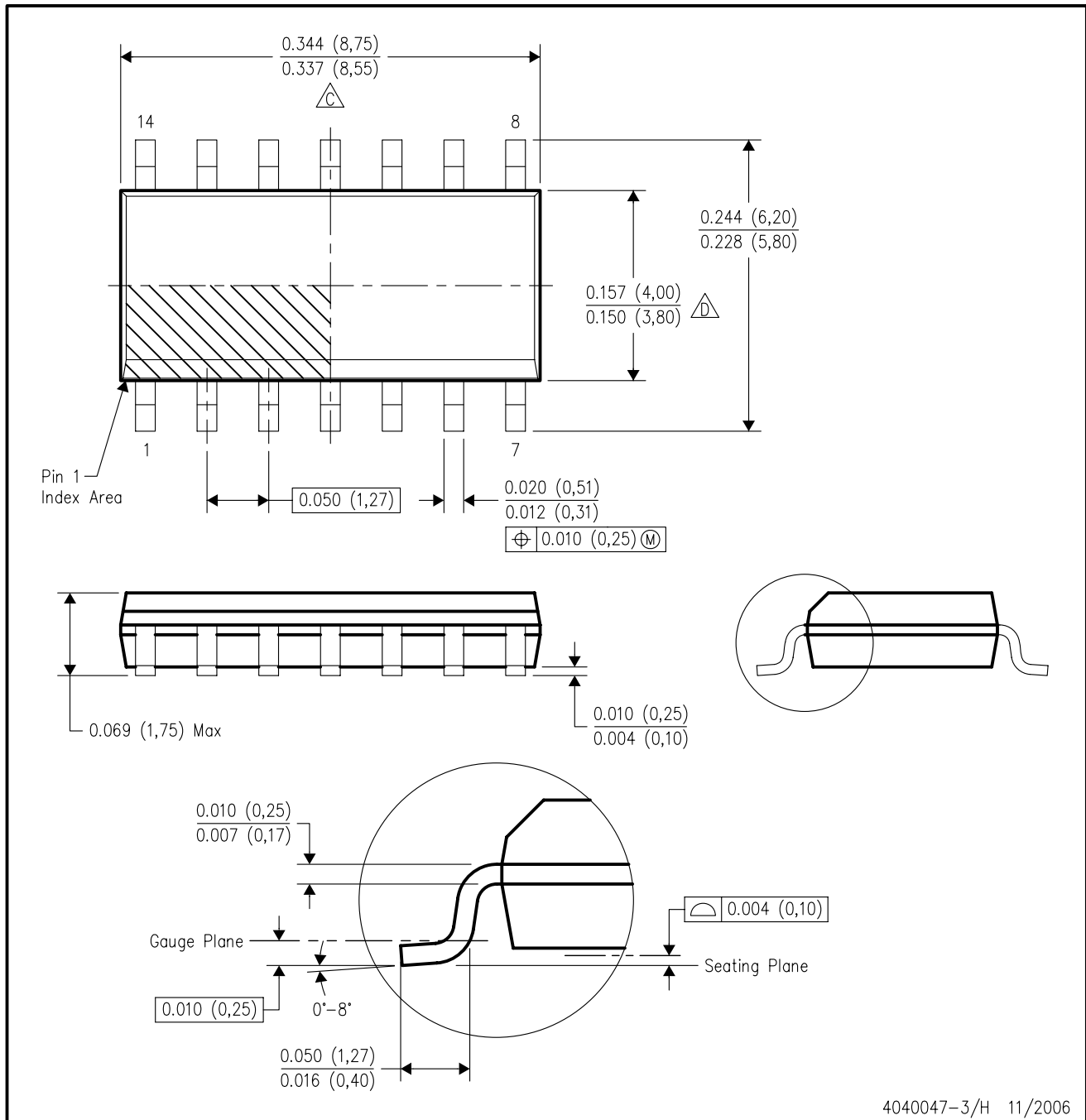

- NOTES:
- A. All linear dimensions are in inches (millimeters).
 - B. This drawing is subject to change without notice.
 - C. Body length does not include mold flash, protrusions, or gate burrs. Mold flash, protrusions, or gate burrs shall not exceed .006 (0,15) per end.
 - D. Body width does not include interlead flash. Interlead flash shall not exceed .017 (0,43) per side.
 - E. Reference JEDEC MS-012 variation AB.

MECHANICAL DATA

MTSS001C – JANUARY 1995 – REVISED FEBRUARY 1999

PW (R-PDSO-G)**

PLASTIC SMALL-OUTLINE PACKAGE

14 PINS SHOWN

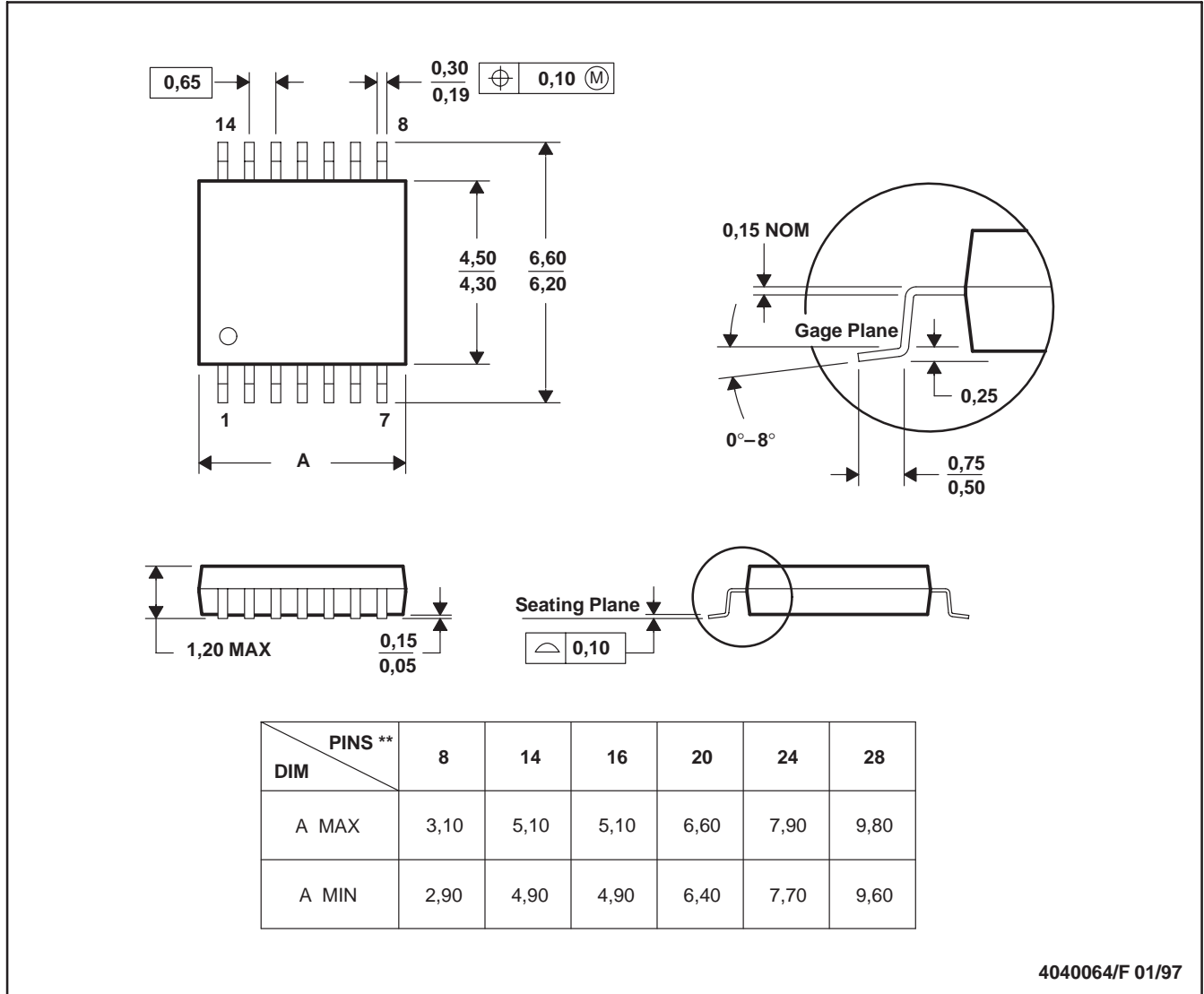

4040064/F 01/97

- NOTES: A. All linear dimensions are in millimeters.
 B. This drawing is subject to change without notice.
 C. Body dimensions do not include mold flash or protrusion not to exceed 0,15.
 D. Falls within JEDEC MO-153

IMPORTANT NOTICE

Texas Instruments Incorporated and its subsidiaries (TI) reserve the right to make corrections, modifications, enhancements, improvements, and other changes to its products and services at any time and to discontinue any product or service without notice. Customers should obtain the latest relevant information before placing orders and should verify that such information is current and complete. All products are sold subject to TI's terms and conditions of sale supplied at the time of order acknowledgment.

TI warrants performance of its hardware products to the specifications applicable at the time of sale in accordance with TI's standard warranty. Testing and other quality control techniques are used to the extent TI deems necessary to support this warranty. Except where mandated by government requirements, testing of all parameters of each product is not necessarily performed.

TI assumes no liability for applications assistance or customer product design. Customers are responsible for their products and applications using TI components. To minimize the risks associated with customer products and applications, customers should provide adequate design and operating safeguards.

TI does not warrant or represent that any license, either express or implied, is granted under any TI patent right, copyright, mask work right, or other TI intellectual property right relating to any combination, machine, or process in which TI products or services are used. Information published by TI regarding third-party products or services does not constitute a license from TI to use such products or services or a warranty or endorsement thereof. Use of such information may require a license from a third party under the patents or other intellectual property of the third party, or a license from TI under the patents or other intellectual property of TI.

Reproduction of information in TI data books or data sheets is permissible only if reproduction is without alteration and is accompanied by all associated warranties, conditions, limitations, and notices. Reproduction of this information with alteration is an unfair and deceptive business practice. TI is not responsible or liable for such altered documentation.

Resale of TI products or services with statements different from or beyond the parameters stated by TI for that product or service voids all express and any implied warranties for the associated TI product or service and is an unfair and deceptive business practice. TI is not responsible or liable for any such statements.

TI products are not authorized for use in safety-critical applications (such as life support) where a failure of the TI product would reasonably be expected to cause severe personal injury or death, unless officers of the parties have executed an agreement specifically governing such use. Buyers represent that they have all necessary expertise in the safety and regulatory ramifications of their applications, and acknowledge and agree that they are solely responsible for all legal, regulatory and safety-related requirements concerning their products and any use of TI products in such safety-critical applications, notwithstanding any applications-related information or support that may be provided by TI. Further, Buyers must fully indemnify TI and its representatives against any damages arising out of the use of TI products in such safety-critical applications.

TI products are neither designed nor intended for use in military/aerospace applications or environments unless the TI products are specifically designated by TI as military-grade or "enhanced plastic." Only products designated by TI as military-grade meet military specifications. Buyers acknowledge and agree that any such use of TI products which TI has not designated as military-grade is solely at the Buyer's risk, and that they are solely responsible for compliance with all legal and regulatory requirements in connection with such use.

TI products are neither designed nor intended for use in automotive applications or environments unless the specific TI products are designated by TI as compliant with ISO/TS 16949 requirements. Buyers acknowledge and agree that, if they use any non-designated products in automotive applications, TI will not be responsible for any failure to meet such requirements.

Following are URLs where you can obtain information on other Texas Instruments products and application solutions:

Products		Applications	
Amplifiers	amplifier.ti.com	Audio	www.ti.com/audio
Data Converters	dataconverter.ti.com	Automotive	www.ti.com/automotive
DSP	dsp.ti.com	Broadband	www.ti.com/broadband
Interface	interface.ti.com	Digital Control	www.ti.com/digitalcontrol
Logic	logic.ti.com	Military	www.ti.com/military
Power Mgmt	power.ti.com	Optical Networking	www.ti.com/opticalnetwork
Microcontrollers	microcontroller.ti.com	Security	www.ti.com/security
RFID	www.ti-rfid.com	Telephony	www.ti.com/telephony
Low Power Wireless	www.ti.com/lpw	Video & Imaging	www.ti.com/video
		Wireless	www.ti.com/wireless