



INA210, INA211 INA212, INA213 INA214

Voltage Output, High or Low Side Measurement, Bi-Directional Zero-Drift Series CURRENT SHUNT MONITOR

FEATURES

- **WIDE COMMON-MODE RANGE:** $-0.3V$ to $26V$
- **OFFSET VOLTAGE:** $\pm 35\mu V$ (Max, INA210)
(Enables shunt drops of $10mV$ full-scale)
- **ACCURACY**
 - $\pm 1\%$ Gain Error (Max over temperature)
 - $0.5\mu V/^\circ C$ Offset Drift (Max)
 - $10ppm/^\circ C$ Gain Drift (Max)
- **CHOICE OF GAINS:**
 - **INA210:** $200V/V$
 - **INA211:** $500V/V$
 - **INA212:** $1000V/V$
 - **INA213:** $50V/V$
 - **INA214:** $100V/V$
- **QUIESCENT CURRENT:** $100\mu A$ (max)
- **SC70 package**

APPLICATIONS

- **NOTEBOOK COMPUTERS**
- **CELL PHONES**
- **TELECOM EQUIPMENT**
- **POWER MANAGEMENT**
- **BATTERY CHARGERS**
- **WELDING EQUIPMENT**

DESCRIPTION

The INA210, INA211, INA212, INA213, and INA214 are voltage output current shunt monitors that can sense drops across shunts at common-mode voltages from $-0.3V$ to $26V$, independent of the supply voltage. Five fixed gains are available: $50V/V$, $100V/V$, $200V/V$, $500V/V$, or $1000V/V$. The low offset of the Zero-Drift architecture enables current sensing with maximum drops across the shunt as low as $10mV$ full-scale.

These devices operate from a single $+2.7V$ to $+26V$ power supply, drawing a maximum of $100\mu A$ of supply current. All versions are specified over the extended operating temperature range ($-40^\circ C$ to $+125^\circ C$), and offered in an SC70 package.

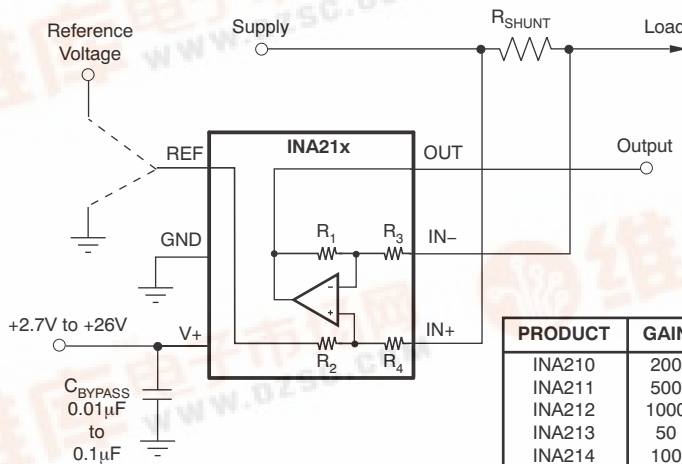

PRODUCT	GAIN	R ₃ and R ₄	R ₁ and R ₂
INA210	200	5k Ω	1M Ω
INA211	500	2k Ω	1M Ω
INA212	1000	1k Ω	1M Ω
INA213	50	20k Ω	1M Ω
INA214	100	10k Ω	1M Ω

Please be aware that an important notice concerning availability, standard warranty, and use in critical applications of Texas Instruments semiconductor products and disclaimers thereto appears at the end of this data sheet.

All trademarks are the property of their respective owners.

INA210, INA211 INA212, INA213 INA214



SBOS437–MAY 2008

www.ti.com



This integrated circuit can be damaged by ESD. Texas Instruments recommends that all integrated circuits be handled with appropriate precautions. Failure to observe proper handling and installation procedures can cause damage.

ESD damage can range from subtle performance degradation to complete device failure. Precision integrated circuits may be more susceptible to damage because very small parametric changes could cause the device not to meet its published specifications.

PACKAGE/ORDERING INFORMATION⁽¹⁾

PRODUCT	GAIN	PACKAGE	PACKAGE DESIGNATOR	PACKAGE MARKING
INA210	200V/V	SC70-6	DCK	CET
INA211 ⁽²⁾	500V/V	SC70-6	DCK	CEU
INA212 ⁽²⁾	1000V/V	SC70-6	DCK	CEV
INA213	50V	SC70-6	DCK	CFT
INA214	100V/V	SC70-6	DCK	CFV

(1) For the most current package and ordering information, see the Package Option Addendum located at the end of this data sheet, or refer to our web site at www.ti.com.

(2) Available Q3, 2008.

ABSOLUTE MAXIMUM RATINGS⁽¹⁾

Over operating free-air temperature range, unless otherwise noted.

		INA210, INA211, INA212, INA213, INA214	UNIT
Supply Voltage		+26	V
Analog Inputs, V_{IN+} , V_{IN-} ⁽²⁾	Differential (V_{IN+} – V_{IN-})	–26 to +26	V
	Common-Mode ⁽³⁾	GND–0.3 to +26	V
REF Input		GND–0.3 to (V+)+0.3	V
Output ⁽³⁾		GND–0.3 to (V+)+0.3	V
Input Current into Any Pin ⁽³⁾		5	mA
Operating Temperature		–55 to +150	°C
Storage Temperature		–65 to +150	°C
Junction Temperature		+150	°C
ESD Ratings:	Human Body Model (HBM)	4000	V
	Charged-Device Model (CDM)	1000	V
	Machine Model (MM)	200	V

(1) Stresses above these ratings may cause permanent damage. Exposure to absolute maximum conditions for extended periods may degrade device reliability. These are stress ratings only, and functional operation of the device at these or any other conditions beyond those specified is not implied.

(2) V_{IN+} and V_{IN-} are the voltages at the IN+ and IN– pins, respectively.

(3) Input Voltage at any pin may exceed the voltage shown if the current at that pin is limited to 5mA.

PIN CONFIGURATION

DCK PACKAGE
SC70-6
(TOP VIEW)

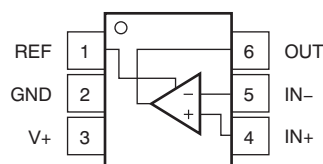

ELECTRICAL CHARACTERISTICS

Boldface limits apply over the specified temperature range, $T_A = -40^{\circ}\text{C}$ to $+125^{\circ}\text{C}$.

At $T_A = +25^{\circ}\text{C}$, $V_{\text{SENSE}} = V_{\text{IN}+} - V_{\text{IN}-}$.

INA210, INA213 and INA214: $V_S = +5\text{V}$, $V_{\text{IN}+} = 12\text{V}$, $V_{\text{REF}} = V_S/2$, unless otherwise noted.

INA211 and INA212: $V_S = +12\text{V}$, $V_{\text{IN}+} = 12\text{V}$, $V_{\text{REF}} = V_S/2$, unless otherwise noted.

PARAMETER	CONDITIONS	INA210, INA211, INA212, INA213, INA214 ⁽¹⁾			UNIT
		MIN	TYP	MAX	
INPUT					
Common-Mode Input Range	V_{CM}	-0.3		26	V
Common-Mode Rejection	CMR	$V_{\text{IN}+} = 0\text{V to } +26\text{V}$, $V_{\text{SENSE}} = 0\text{mV}$			
INA210, INA211, INA212, INA214		105	140		dB
INA213		100	120		dB
Offset Voltage, RTI ⁽²⁾	V_{OS}	$V_{\text{SENSE}} = 0\text{mV}$			
INA210, INA211, INA212			± 0.55	± 35	μV
INA213			± 5	± 100	μV
INA214			± 1	± 60	μV
vs Temperature	dV_{OS}/dT		0.1	0.5	$\mu\text{V}/^{\circ}\text{C}$
vs Power Supply	PSR	$V_S = +2.7\text{V to } +18\text{V}$, $V_{\text{IN}+} = +18\text{V}$, $V_{\text{SENSE}} = 0\text{mV}$			
			± 0.1	± 10	$\mu\text{V}/\text{V}$
Input Bias Current	I_B	15	28	35	μA
Input Offset Current	I_{OS}		± 0.02		μA
OUTPUT					
Gain, INA210	G		200		V/V
INA211			500		V/V
INA212			1000		V/V
INA213			50		V/V
INA214			100		V/V
Gain Error		$V_{\text{SENSE}} = -5\text{mV to } 5\text{mV}$			
vs Temperature			± 0.02	± 1	%
			3	10	ppm/ $^{\circ}\text{C}$
Nonlinearity Error		$V_{\text{SENSE}} = -5\text{mV to } 5\text{mV}$			
			± 0.01		%
Maximum Capacitive Load		No sustained oscillation			
			1		nF
VOLTAGE OUTPUT⁽³⁾					
Swing to V+ Power Supply Rail					
Swing to GND					
			(V+)-0.05 (V _{GND})+0.005	(V+)-0.2 (V _{GND})+0.05	V V
FREQUENCY RESPONSE					
Bandwidth	GBW	$C_{\text{LOAD}} = 10\text{pF}$			
			14		kHz
Slew Rate	SR		0.4		V/ μs
NOISE, RTI⁽²⁾					
Voltage Noise Density			25		nV/ $\sqrt{\text{Hz}}$
POWER SUPPLY					
Operating Voltage Range	V_S	+2.7		+26	V
Quiescent Current	I_Q	$V_{\text{SENSE}} = 0\text{mV}$			
			65	100	μA
Over Temperature				115	μA
TEMPERATURE RANGE					
Specified Range		-40		+125	$^{\circ}\text{C}$
Operating Range		-55		+150	$^{\circ}\text{C}$
Thermal Resistance	θ_{JA}		250		$^{\circ}\text{C}/\text{W}$
SC70					

(1) Specifications for INA211 and INA212 are preview.

(2) RTI = referred-to-input.

(3) See Typical Characteristic curve, Output Voltage Swing vs Output Current (Figure 10).

TYPICAL CHARACTERISTICS

The INA210 is used for typical characteristics at $T_A = +25^\circ\text{C}$, $V_S = +5\text{V}$, $V_{IN+} = 12\text{V}$, and $V_{REF} = V_S/2$, unless otherwise noted.

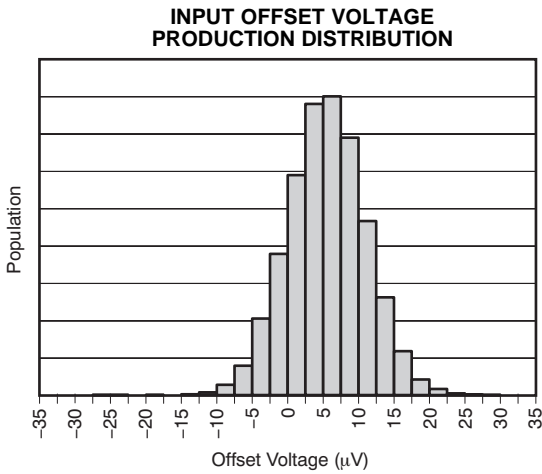

Figure 1.

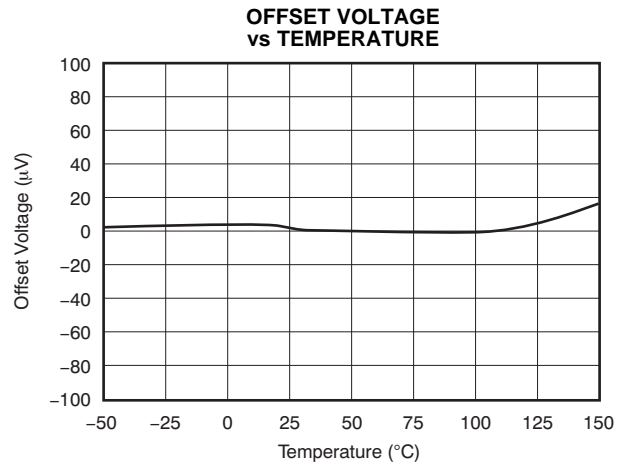

Figure 2.

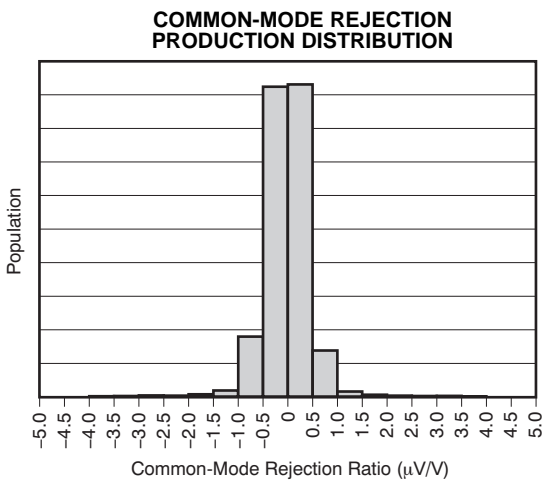

Figure 3.

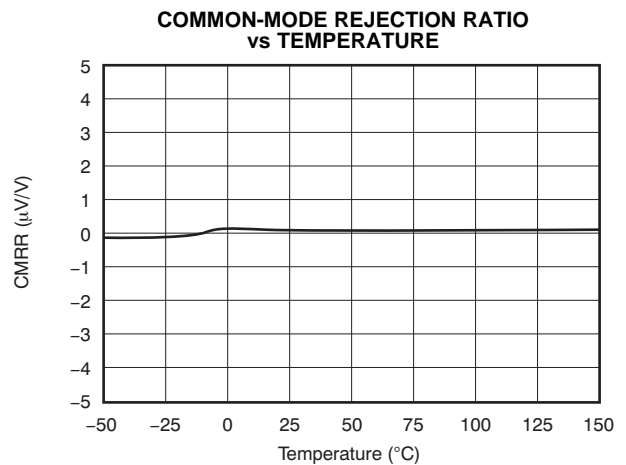

Figure 4.

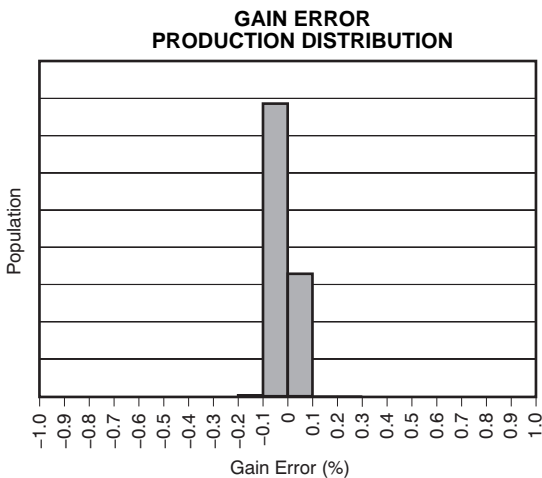

Figure 5.

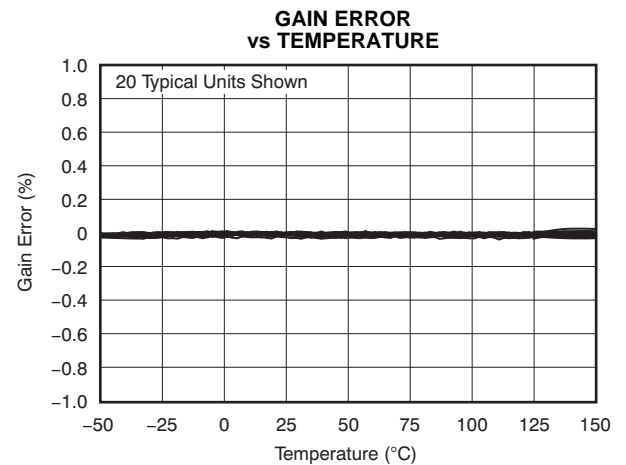

Figure 6.

TYPICAL CHARACTERISTICS (continued)

The INA210 is used for typical characteristics at $T_A = +25^\circ\text{C}$, $V_S = +5\text{V}$, $V_{IN+} = 12\text{V}$, and $V_{REF} = V_S/2$, unless otherwise noted.

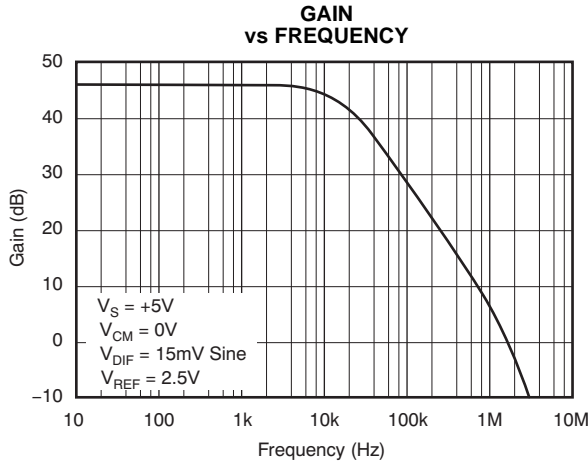

Figure 7.

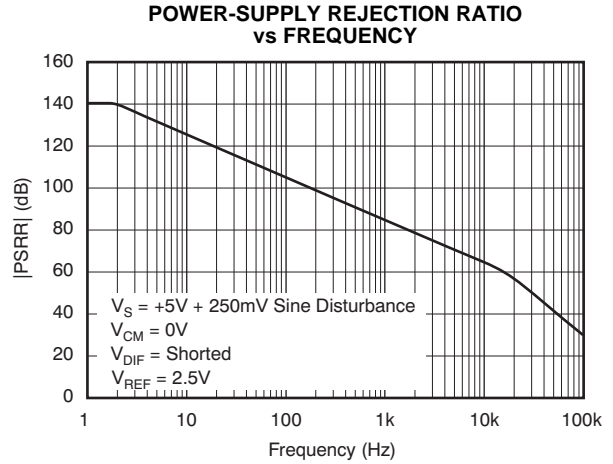

Figure 8.

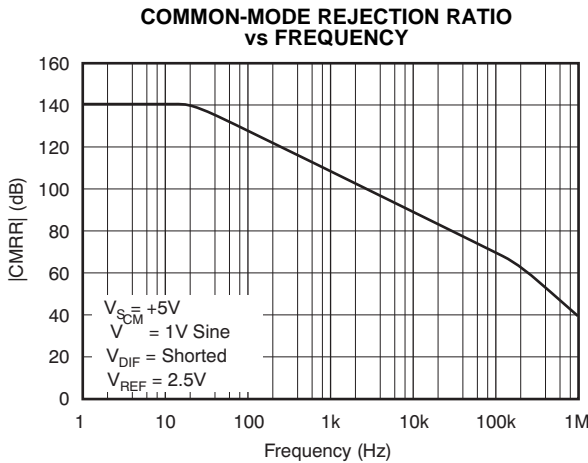

Figure 9.

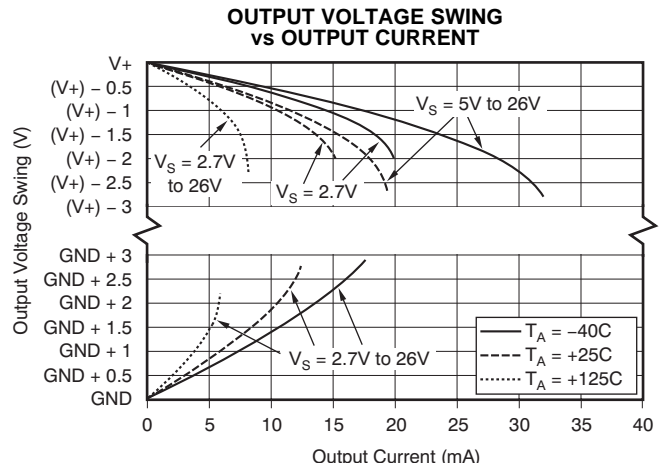

Figure 10.

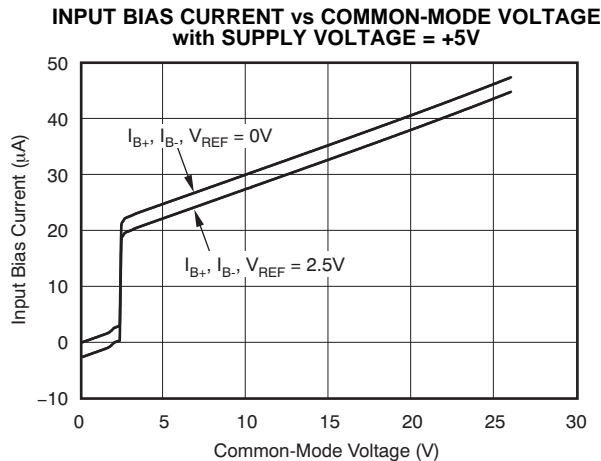

Figure 11.

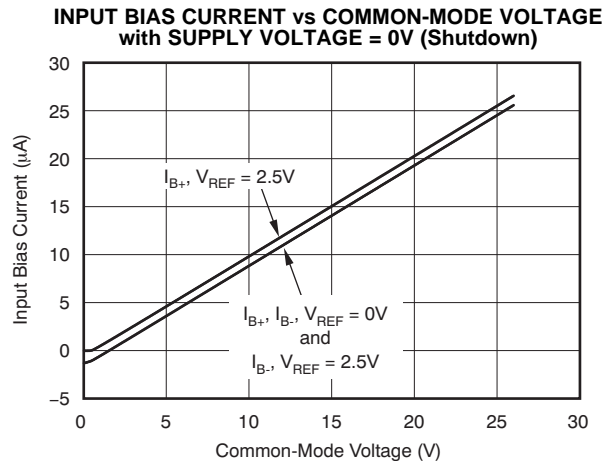

Figure 12.

TYPICAL CHARACTERISTICS (continued)

The INA210 is used for typical characteristics at $T_A = +25^\circ\text{C}$, $V_S = +5\text{V}$, $V_{IN+} = 12\text{V}$, and $V_{REF} = V_S/2$, unless otherwise noted.

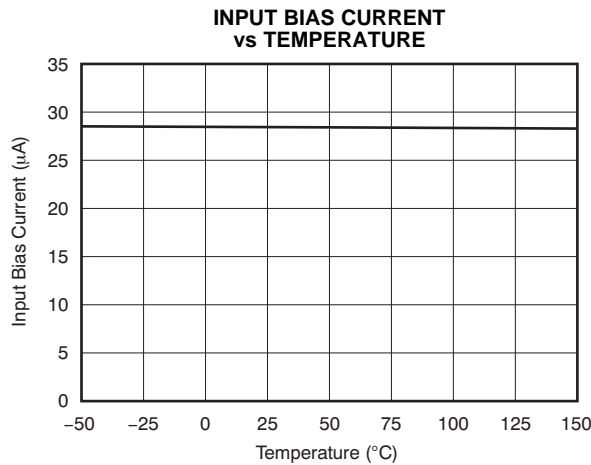

Figure 13.

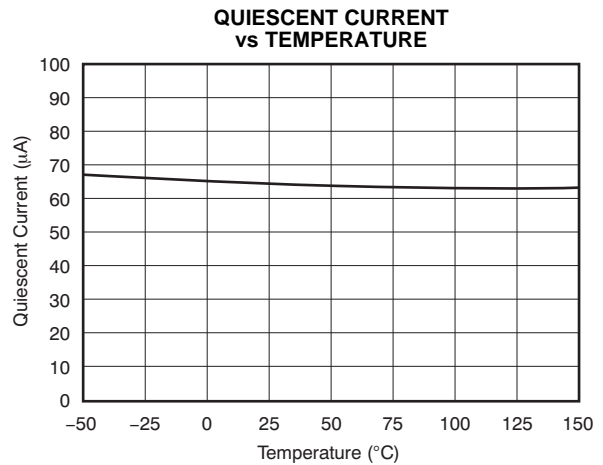

Figure 14.

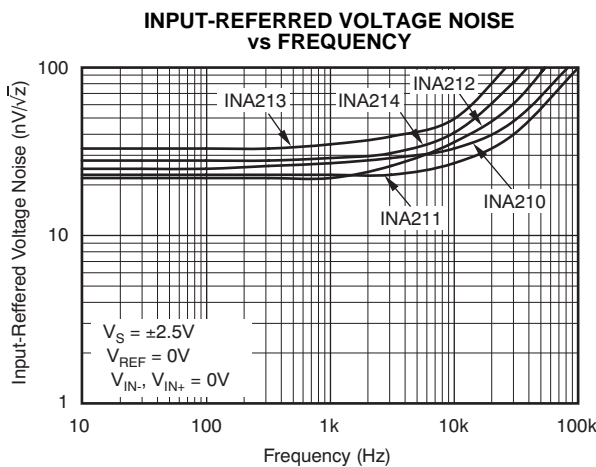

Figure 15.

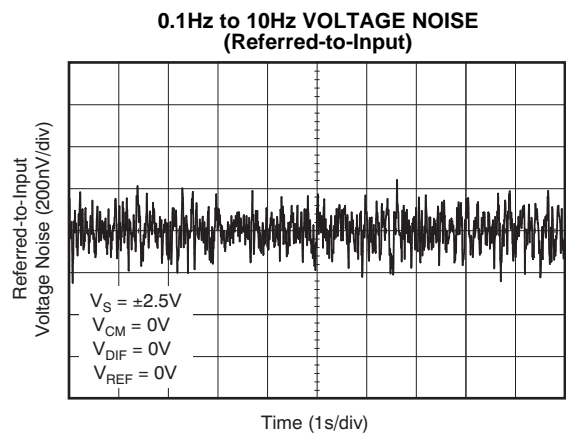

Figure 16.

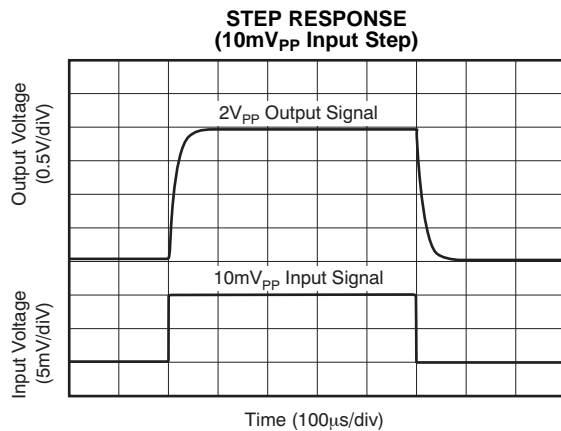

Figure 17.

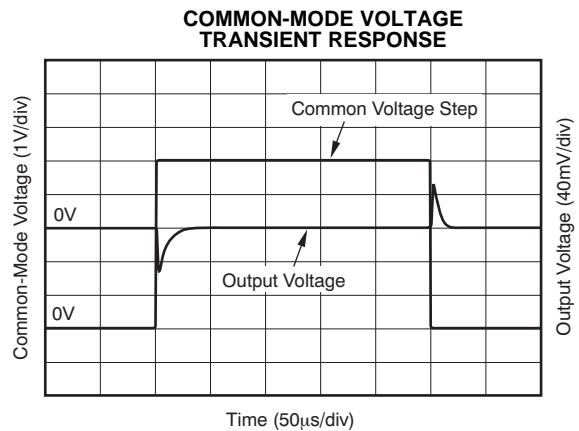

Figure 18.

TYPICAL CHARACTERISTICS (continued)

The INA210 is used for typical characteristics at $T_A = +25^\circ\text{C}$, $V_S = +5\text{V}$, $V_{IN+} = 12\text{V}$, and $V_{REF} = V_S/2$, unless otherwise noted.

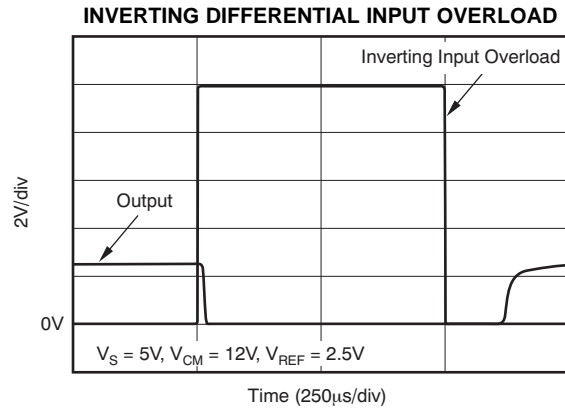

Figure 19.

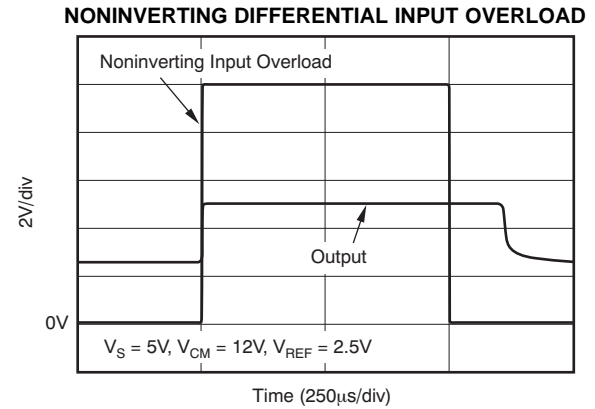

Figure 20.

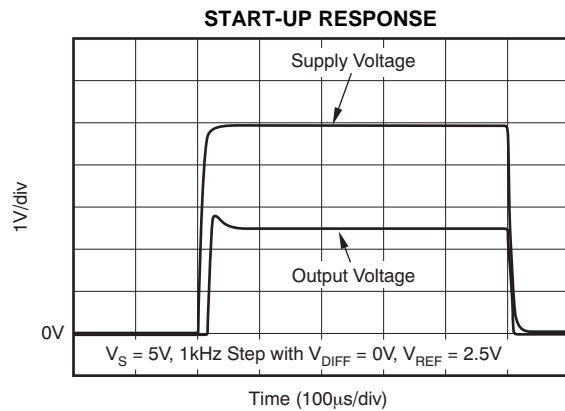

Figure 21.

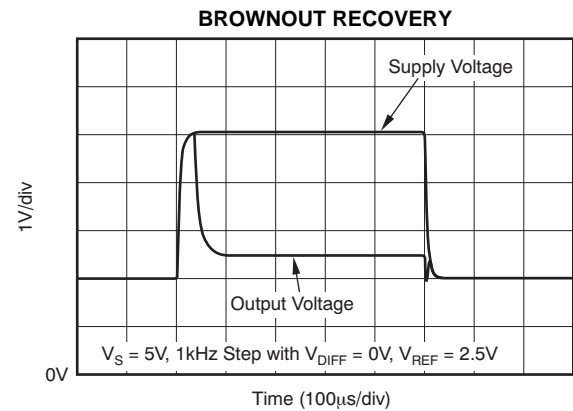

Figure 22.

APPLICATION INFORMATION

BASIC CONNECTIONS

Figure 23 shows the basic connections of the INA210-INA214. The input pins, IN+ and IN–, should be connected as closely as possible to the shunt resistor to minimize any resistance in series with the shunt resistance.

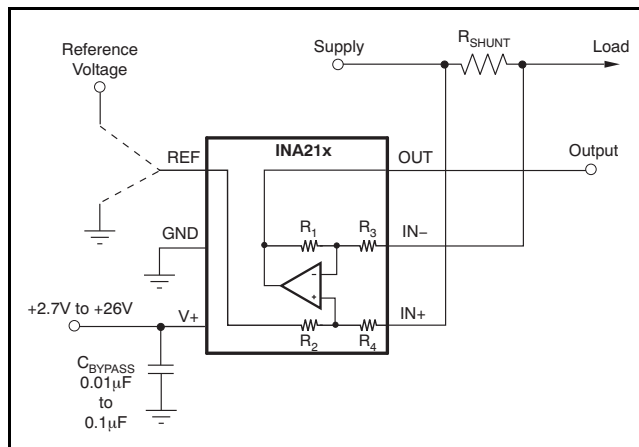

Figure 23. Typical Application

Power-supply bypass capacitors are required for stability. Applications with noisy or high impedance power supplies may require additional decoupling capacitors to reject power-supply noise. Connect bypass capacitors close to the device pins.

POWER SUPPLY

The input circuitry of the INA210-INA214 can accurately measure beyond its power-supply voltage, V+. For example, the V+ power supply can be 5V, whereas the load power supply voltage can be as high as +26V. However, the output voltage range of the OUT terminal is limited by the voltages on the power-supply pin. Note also that the INA210-INA214 can withstand the full –0.3V to +26V in the input pins, regardless of whether the device has power applied or not.

SELECTING R_s

The zero-drift offset performance of the INA210-INA214 offers several benefits. Most often, the primary advantage of the low offset characteristic enables lower full-scale drops across the shunt. For example, non-zero-drift current shunt monitors typically require a full-scale range of 100mV. The INA210-INA214 series gives equivalent accuracy at a full-scale range on the order of 10mV. This accuracy reduces shunt dissipation by an order of magnitude with many additional benefits.

Alternatively, there are applications that must measure current over a wide dynamic range that can take advantage of the low offset on the low end of the measurement. Most often, these applications can use the lower gain INA213 or INA214 to accommodate larger shunt drops on the upper-end of the scale. For instance, an INA213 operating on a 3.3V supply could easily handle a full-scale shunt drop of 60mV, with only 60 μ V of offset.

UNIDIRECTIONAL OPERATION

Unidirectional operation allows the INA210-INA214 to measure currents through a resistive shunt in one direction. The most frequent case of unidirectional operation sets the output at ground by connecting the REF pin to ground. In unidirectional applications where the highest possible accuracy is desirable at very low inputs, bias the REF pin to a convenient value above 50mV to get the device output swing into the linear range for zero inputs.

A less frequent case of unipolar output biasing is to bias the output by connecting the REF pin to the supply; in this case, the quiescent output for zero input is at quiescent supply. This configuration would only respond to negative currents (inverted voltage polarity at the device input).

BIDIRECTIONAL OPERATION

Bidirectional operation allows the INA210-INA214 to measure currents through a resistive shunt in two directions. In this case, the output can be set anywhere within the limits of what the reference inputs allow (that is, between 0V to V+). Typically, it is set at half-scale for equal range in both directions. In some cases, however, it is set at a voltage other than half-scale when the bidirectional current is nonsymmetrical.

The quiescent output voltage is set by applying voltage to the reference input. Under zero differential input conditions the output assumes the same voltage as is applied to the reference input.

INPUT FILTERING

An obvious and straightforward location for filtering is at the output of the INA210-INA214; however, this location negates the advantage of the low output impedance of the internal buffer. The only other option for filtering is at the input pins of the INA210-INA214; this location requires consideration of the $\pm 30\%$ tolerance of the input impedance. Figure 24 shows a filter placed at the input pins.

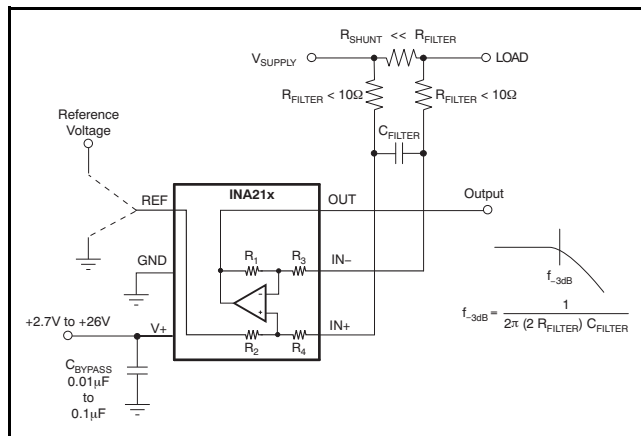

Figure 24. Input Filter

Using the lowest possible resistor values minimizes both the initial shift in gain and effects of tolerance. The effect on initial gain is given by Equation 1:

$$\text{GainError\%} = 100 - [100 \times \{R/(R + R_{\text{FILT}})\}] \quad (1)$$

Where R is the value for R_3 or R_4 from Table 1 for the model is in question.

Table 1.

PRODUCT	GAIN	R ₃ AND R ₄
INA210	200	5kΩ
INA211	500	2kΩ
INA212	1000	1kΩ
INA213	50	20kΩ
INA214	100	10kΩ

Using an INA212, for example, the total effect on gain error can be calculated by replacing the R with 1kΩ– 30%, (or 700Ω) or 1kΩ+ 30% (or 1.3kΩ). The tolerance extremes of R_{FILT} can also be inserted into the equation. If a pair of 100Ω, 1% resistors are used on the inputs, the initial gain error is approximately 2%.

SHUTTING DOWN THE INA210-INA214 SERIES

While the INA210-INA214 series does not have a shutdown pin, its low power consumption allows powering from the output of a logic gate or transistor switch that can turn on and turn off the INA210-INA214 power-supply quiescent current.

However, in current shunt monitoring applications, there is also a concern for how much current is drained from the shunt circuit in shutdown conditions. Evaluating this current drain involves considering the simplified schematic of the INA210-INA214 in shutdown mode shown in Figure 25.

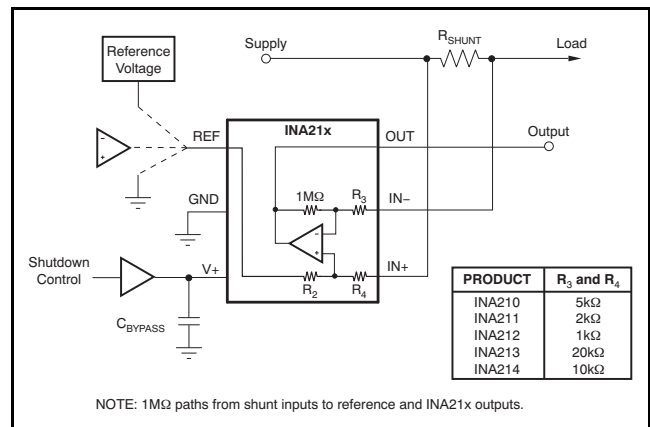

Figure 25. Basic Circuit for Shutting Down INA210-INA214 with Grounded Reference

Note that there is typically slightly more than 1MΩ impedance (from the combination of 1MΩ feedback and 5kΩ input resistors) from each input of the INA210-INA214 to the OUT pin and to the REF pin. The amount of current flowing through these pins depends on the respective ultimate connection. For example, if the REF pin is grounded, the calculation of the effect of the 1MΩ impedance from the shunt to ground is straightforward. However, if the reference or op amp is powered while the INA210-INA214 is shut down, the calculation is direct; instead of assuming 1MΩ to ground, however, assume 1MΩ to the reference voltage. If the reference or op amp is also shut down, some knowledge of the reference or op amp output impedance under shutdown conditions is required. For instance, if the reference source behaves as an open circuit when it is unpowered, little or no current flows through the 1MΩ path.

Regarding the 1MΩ path to the output pin, the output stage of a disabled INA210-INA214 does constitute a good path to ground; consequently, this current is directly proportional to a shunt common-mode voltage impressed across a 1MΩ resistor.

As a final note, when the device is powered up, there is an additional, nearly constant, and well-matched $25\mu\text{A}$ that flows in each of the inputs as long as the shunt common-mode voltage is 3V or higher. Below 2V common-mode, the only current effects are the result of the $1\text{M}\Omega$ resistors.

REF INPUT IMPEDANCE EFFECTS

As with any difference amplifier, the INA210-INA214 series common-mode rejection ratio is affected by any impedance present at the REF input. This concern is not a problem when the REF pin is connected directly to most references or power supplies. When using resistive dividers from the power supply or a reference voltage, the REF pin should be buffered by an op amp.

In systems where the INA210-INA214 output can be sensed differentially, such as by a differential input analog-to-digital converter (ADC) or by using two separate ADC inputs, the effects of external impedance on the REF input can be cancelled. Figure 26 depicts a method of taking the output from the INA210-INA214 by using the REF pin as a reference.

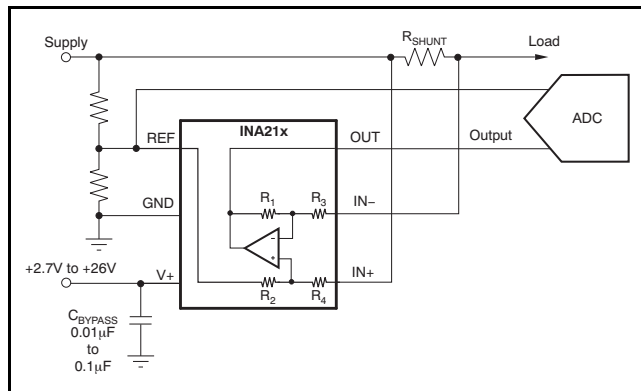

Figure 26. Sensing INA210-INA214 to Cancel Effects of Impedance on the REF Input

USING THE INA210 WITH COMMON-MODE TRANSIENTS ABOVE 26V

With a small amount of additional circuitry, the INA210-INA214 series can be used in circuits subject to transients higher than 26V, such as automotive applications. Use only zener diode or zener-type transient absorbers (sometimes referred to as *Transzorbs*)— any other type of transient absorber has an unacceptable time delay. Start by adding a pair of resistors as shown in Figure 27 as a working impedance for the zener. It is desirable to keep these resistors as small as possible, most often around 10Ω . Larger values can be used with an effect on gain that is discussed in the section on input filtering. Because this circuit is limiting only short-term transients, many applications are satisfied with a 10Ω resistor along with conventional zener diodes of the lowest power rating that can be found. This combination uses the least amount of board space. These diodes can be found in packages as small as SOT-523 or SOD-523.

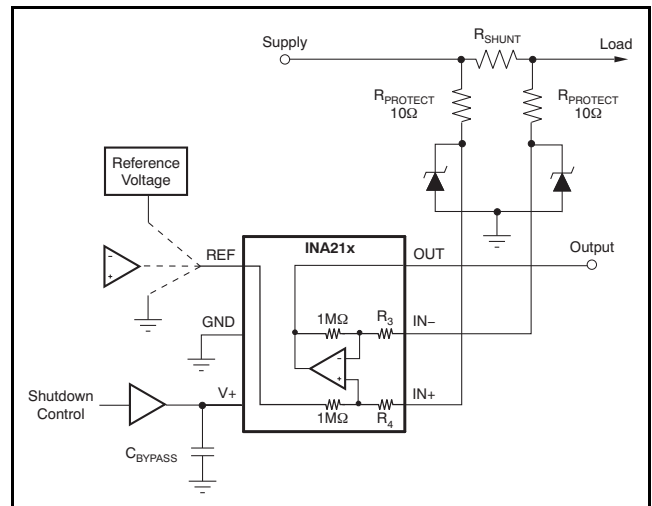

Figure 27. INA210-INA214 Transient Protection Using Dual Zener Diodes

In the event that low-power zeners do not have sufficient transient absorption capability and a higher power transient absorber must be used, the most package-efficient solution then involves using a single transient absorber and back-to-back diodes between the device inputs. The most space-efficient solutions are dual series-connected diodes in a single SOT-523 or SOD-523 package. This method is shown in Figure 28. In either of these examples, the total board area required by the INA210-INA214 with all protective components is less than that of an SO-8 package, and only slightly greater than that of an MSOP-8 package.

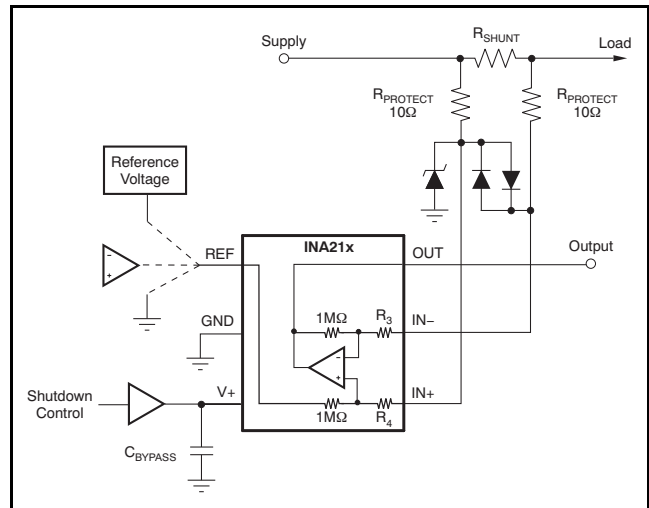

Figure 28. INA210-INA214 Transient Protection Using a Single Transzorb and Input Clamps

PACKAGING INFORMATION

Orderable Device	Status ⁽¹⁾	Package Type	Package Drawing	Pins	Package Qty	Eco Plan ⁽²⁾	Lead/Ball Finish	MSL Peak Temp ⁽³⁾
INA210AIDCKR	ACTIVE	SC70	DCK	6	3000	Green (RoHS & no Sb/Br)	CU NIPDAU	Level-2-260C-1 YEAR
INA210AIDCKRG4	ACTIVE	SC70	DCK	6	3000	Green (RoHS & no Sb/Br)	CU NIPDAU	Level-2-260C-1 YEAR
INA210AIDCKT	ACTIVE	SC70	DCK	6	250	Green (RoHS & no Sb/Br)	CU NIPDAU	Level-2-260C-1 YEAR
INA210AIDCKTG4	ACTIVE	SC70	DCK	6	250	Green (RoHS & no Sb/Br)	CU NIPDAU	Level-2-260C-1 YEAR
INA211AIDCKR	PREVIEW	SC70	DCK	6	3000	TBD	Call TI	Call TI
INA211AIDCKT	PREVIEW	SC70	DCK	6	250	TBD	Call TI	Call TI
INA212AIDCKR	PREVIEW	SC70	DCK	6	3000	TBD	Call TI	Call TI
INA212AIDCKT	PREVIEW	SC70	DCK	6	250	TBD	Call TI	Call TI
INA213AIDCKR	ACTIVE	SC70	DCK	6	3000	Green (RoHS & no Sb/Br)	CU NIPDAU	Level-2-260C-1 YEAR
INA213AIDCKRG4	ACTIVE	SC70	DCK	6	3000	Green (RoHS & no Sb/Br)	CU NIPDAU	Level-2-260C-1 YEAR
INA213AIDCKT	ACTIVE	SC70	DCK	6	250	Green (RoHS & no Sb/Br)	CU NIPDAU	Level-2-260C-1 YEAR
INA213AIDCKTG4	ACTIVE	SC70	DCK	6	250	Green (RoHS & no Sb/Br)	CU NIPDAU	Level-2-260C-1 YEAR
INA214AIDCKR	ACTIVE	SC70	DCK	6	3000	Green (RoHS & no Sb/Br)	CU NIPDAU	Level-2-260C-1 YEAR
INA214AIDCKRG4	ACTIVE	SC70	DCK	6	3000	Green (RoHS & no Sb/Br)	CU NIPDAU	Level-2-260C-1 YEAR
INA214AIDCKT	ACTIVE	SC70	DCK	6	250	Green (RoHS & no Sb/Br)	CU NIPDAU	Level-2-260C-1 YEAR
INA214AIDCKTG4	ACTIVE	SC70	DCK	6	250	Green (RoHS & no Sb/Br)	CU NIPDAU	Level-2-260C-1 YEAR

⁽¹⁾ The marketing status values are defined as follows:

ACTIVE: Product device recommended for new designs.

LIFEBUY: TI has announced that the device will be discontinued, and a lifetime-buy period is in effect.

NRND: Not recommended for new designs. Device is in production to support existing customers, but TI does not recommend using this part in a new design.

PREVIEW: Device has been announced but is not in production. Samples may or may not be available.

OBSOLETE: TI has discontinued the production of the device.

⁽²⁾ Eco Plan - The planned eco-friendly classification: Pb-Free (RoHS), Pb-Free (RoHS Exempt), or Green (RoHS & no Sb/Br) - please check <http://www.ti.com/productcontent> for the latest availability information and additional product content details.

TBD: The Pb-Free/Green conversion plan has not been defined.

Pb-Free (RoHS): TI's terms "Lead-Free" or "Pb-Free" mean semiconductor products that are compatible with the current RoHS requirements for all 6 substances, including the requirement that lead not exceed 0.1% by weight in homogeneous materials. Where designed to be soldered at high temperatures, TI Pb-Free products are suitable for use in specified lead-free processes.

Pb-Free (RoHS Exempt): This component has a RoHS exemption for either 1) lead-based flip-chip solder bumps used between the die and package, or 2) lead-based die adhesive used between the die and leadframe. The component is otherwise considered Pb-Free (RoHS compatible) as defined above.

Green (RoHS & no Sb/Br): TI defines "Green" to mean Pb-Free (RoHS compatible), and free of Bromine (Br) and Antimony (Sb) based flame retardants (Br or Sb do not exceed 0.1% by weight in homogeneous material)

⁽³⁾ MSL, Peak Temp. -- The Moisture Sensitivity Level rating according to the JEDEC industry standard classifications, and peak solder temperature.

Important Information and Disclaimer:The information provided on this page represents TI's knowledge and belief as of the date that it is provided. TI bases its knowledge and belief on information provided by third parties, and makes no representation or warranty as to the accuracy of such information. Efforts are underway to better integrate information from third parties. TI has taken and continues to take reasonable steps to provide representative and accurate information but may not have conducted destructive testing or chemical analysis on incoming materials and chemicals. TI and TI suppliers consider certain information to be proprietary, and thus CAS numbers and other limited information may not be available for release.

In no event shall TI's liability arising out of such information exceed the total purchase price of the TI part(s) at issue in this document sold by TI to Customer on an annual basis.

TAPE AND REEL INFORMATION

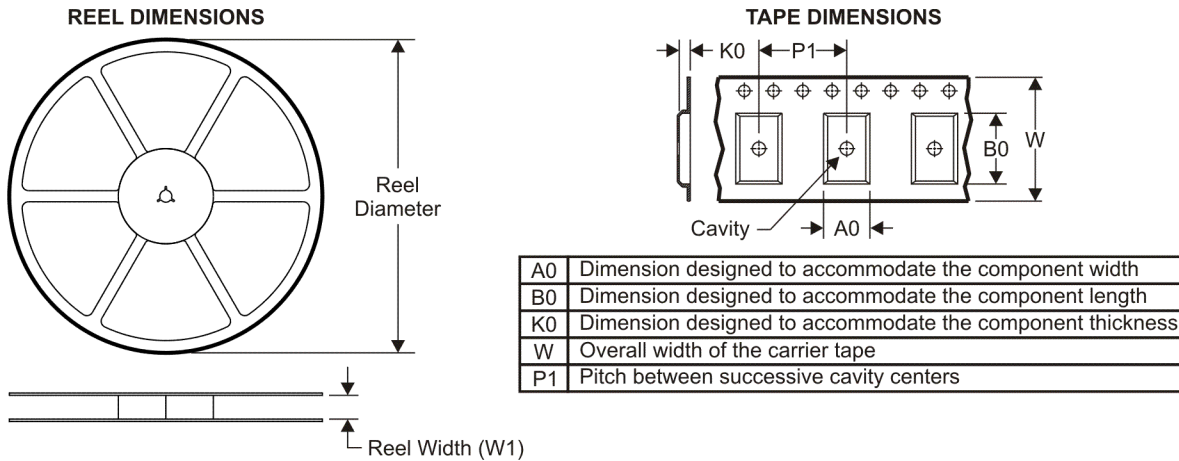

QUADRANT ASSIGNMENTS FOR PIN 1 ORIENTATION IN TAPE

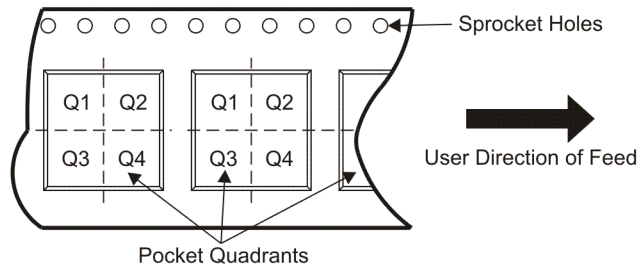

*All dimensions are nominal

Device	Package Type	Package Drawing	Pins	SPQ	Reel Diameter (mm)	Reel Width W1 (mm)	A0 (mm)	B0 (mm)	K0 (mm)	P1 (mm)	W (mm)	Pin1 Quadrant
INA210AIDCKR	SC70	DCK	6	3000	180.0	9.2	4.0	2.24	2.34	4.0	8.0	Q3
INA210AIDCKT	SC70	DCK	6	250	180.0	9.2	4.0	2.24	2.34	4.0	8.0	Q3
INA213AIDCKR	SC70	DCK	6	3000	180.0	9.2	4.0	2.24	2.34	4.0	8.0	Q3
INA213AIDCKT	SC70	DCK	6	250	180.0	9.2	4.0	2.24	2.34	4.0	8.0	Q3
INA214AIDCKR	SC70	DCK	6	3000	180.0	9.2	4.0	2.24	2.34	4.0	8.0	Q3
INA214AIDCKT	SC70	DCK	6	250	180.0	9.2	4.0	2.24	2.34	4.0	8.0	Q3

TAPE AND REEL BOX DIMENSIONS

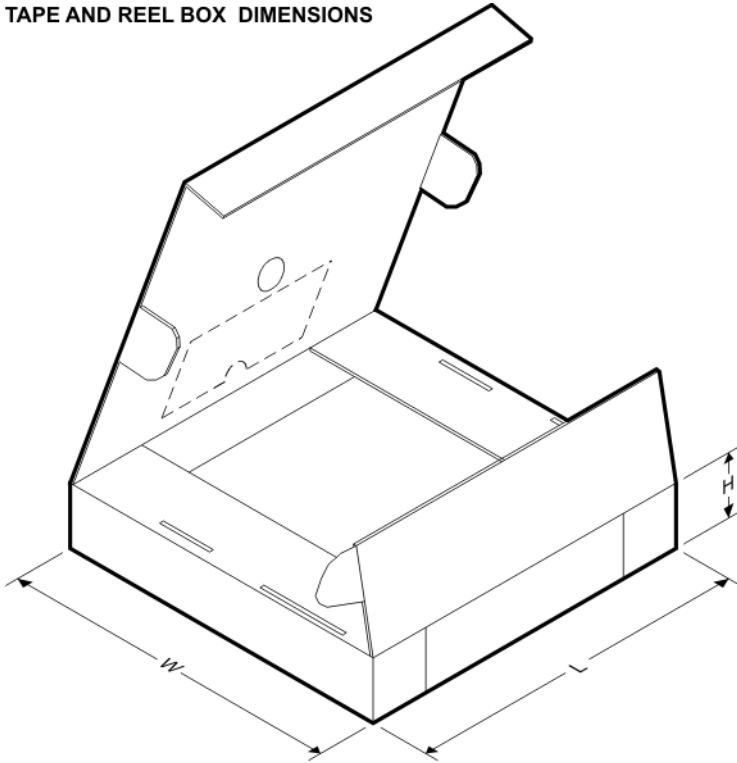

*All dimensions are nominal

Device	Package Type	Package Drawing	Pins	SPQ	Length (mm)	Width (mm)	Height (mm)
INA210AIDCKR	SC70	DCK	6	3000	202.0	201.0	28.0
INA210AIDCKT	SC70	DCK	6	250	202.0	201.0	28.0
INA213AIDCKR	SC70	DCK	6	3000	202.0	201.0	28.0
INA213AIDCKT	SC70	DCK	6	250	202.0	201.0	28.0
INA214AIDCKR	SC70	DCK	6	3000	202.0	201.0	28.0
INA214AIDCKT	SC70	DCK	6	250	202.0	201.0	28.0

IMPORTANT NOTICE

Texas Instruments Incorporated and its subsidiaries (TI) reserve the right to make corrections, modifications, enhancements, improvements, and other changes to its products and services at any time and to discontinue any product or service without notice. Customers should obtain the latest relevant information before placing orders and should verify that such information is current and complete. All products are sold subject to TI's terms and conditions of sale supplied at the time of order acknowledgment.

TI warrants performance of its hardware products to the specifications applicable at the time of sale in accordance with TI's standard warranty. Testing and other quality control techniques are used to the extent TI deems necessary to support this warranty. Except where mandated by government requirements, testing of all parameters of each product is not necessarily performed.

TI assumes no liability for applications assistance or customer product design. Customers are responsible for their products and applications using TI components. To minimize the risks associated with customer products and applications, customers should provide adequate design and operating safeguards.

TI does not warrant or represent that any license, either express or implied, is granted under any TI patent right, copyright, mask work right, or other TI intellectual property right relating to any combination, machine, or process in which TI products or services are used. Information published by TI regarding third-party products or services does not constitute a license from TI to use such products or services or a warranty or endorsement thereof. Use of such information may require a license from a third party under the patents or other intellectual property of the third party, or a license from TI under the patents or other intellectual property of TI.

Reproduction of TI information in TI data books or data sheets is permissible only if reproduction is without alteration and is accompanied by all associated warranties, conditions, limitations, and notices. Reproduction of this information with alteration is an unfair and deceptive business practice. TI is not responsible or liable for such altered documentation. Information of third parties may be subject to additional restrictions.

Resale of TI products or services with statements different from or beyond the parameters stated by TI for that product or service voids all express and any implied warranties for the associated TI product or service and is an unfair and deceptive business practice. TI is not responsible or liable for any such statements.

TI products are not authorized for use in safety-critical applications (such as life support) where a failure of the TI product would reasonably be expected to cause severe personal injury or death, unless officers of the parties have executed an agreement specifically governing such use. Buyers represent that they have all necessary expertise in the safety and regulatory ramifications of their applications, and acknowledge and agree that they are solely responsible for all legal, regulatory and safety-related requirements concerning their products and any use of TI products in such safety-critical applications, notwithstanding any applications-related information or support that may be provided by TI. Further, Buyers must fully indemnify TI and its representatives against any damages arising out of the use of TI products in such safety-critical applications.

TI products are neither designed nor intended for use in military/aerospace applications or environments unless the TI products are specifically designated by TI as military-grade or "enhanced plastic." Only products designated by TI as military-grade meet military specifications. Buyers acknowledge and agree that any such use of TI products which TI has not designated as military-grade is solely at the Buyer's risk, and that they are solely responsible for compliance with all legal and regulatory requirements in connection with such use.

TI products are neither designed nor intended for use in automotive applications or environments unless the specific TI products are designated by TI as compliant with ISO/TS 16949 requirements. Buyers acknowledge and agree that, if they use any non-designated products in automotive applications, TI will not be responsible for any failure to meet such requirements.

Following are URLs where you can obtain information on other Texas Instruments products and application solutions:

Products		Applications	
Amplifiers	amplifier.ti.com	Audio	www.ti.com/audio
Data Converters	dataconverter.ti.com	Automotive	www.ti.com/automotive
DSP	dsp.ti.com	Broadband	www.ti.com/broadband
Clocks and Timers	www.ti.com/clocks	Digital Control	www.ti.com/digitalcontrol
Interface	interface.ti.com	Medical	www.ti.com/medical
Logic	logic.ti.com	Military	www.ti.com/military
Power Mgmt	power.ti.com	Optical Networking	www.ti.com/opticalnetwork
Microcontrollers	microcontroller.ti.com	Security	www.ti.com/security
RFID	www.ti-rfid.com	Telephony	www.ti.com/telephony
RF/IF and ZigBee® Solutions	www.ti.com/lprf	Video & Imaging	www.ti.com/video
		Wireless	www.ti.com/wireless

Mailing Address: Texas Instruments, Post Office Box 655303, Dallas, Texas 75265
Copyright © 2008, Texas Instruments Incorporated