



INA333

Micro-Power (50µA), Zero-Drift, Rail-to-Rail Out Instrumentation Amplifier

FEATURES

- **LOW OFFSET VOLTAGE:** 25µV (max), $G \geq 100$
- **LOW DRIFT:** 0.1µV/°C, $G \geq 100$
- **LOW NOISE:** 50nV/√Hz, $G \geq 100$
- **HIGH CMRR:** 100dB (min), $G \geq 10$
- **LOW INPUT BIAS CURRENT:** 200pA (max)
- **SUPPLY RANGE:** +1.8V to +5.5V
- **INPUT VOLTAGE:** (V-) +0.1V to (V+) -0.1V
- **OUTPUT RANGE:** (V-) +0.05V to (V+) -0.05V
- **LOW QUIESCENT CURRENT:** 50µA
- **OPERATING TEMPERATURE:** -40°C to +125°C
- **RFI FILTERED INPUTS**
- **MSOP-8 AND DFN-8 PACKAGES**

APPLICATIONS

- BRIDGE AMPLIFIERS
- ECG AMPLIFIERS
- PRESSURE SENSORS
- MEDICAL INSTRUMENTATION
- PORTABLE INSTRUMENTATION
- WEIGH SCALES
- THERMOCOUPLE AMPLIFIERS
- RTD SENSOR AMPLIFIERS
- DATA ACQUISITION

DESCRIPTION

The INA333 is a low-power, precision instrumentation amplifier offering excellent accuracy. The versatile 3-op amp design, small size, and low power make it ideal for a wide range of portable applications.

A single external resistor sets any gain from 1 to 1000. The INA333 is designed to use an industry-standard gain equation: $G = 1 + (100k\Omega/R_G)$.

The INA333 provides very low offset voltage (25µV, $G \geq 100$), excellent offset voltage drift (0.1µV/°C, $G \geq 100$), and high common-mode rejection (100dB at $G \geq 10$). It operates with power supplies as low as 1.8V (±0.9V), and quiescent current is only 50µA—ideal for battery-operated systems. Using autocalibration techniques to ensure excellent precision over the extended industrial temperature range, the INA333 also offers exceptionally low noise density (50nV/√Hz) that extends down to dc.

The INA333 is available in both MSOP-8 and DFN-8 surface-mount packages and is specified over the $T_A = -40^\circ\text{C}$ to $+125^\circ\text{C}$ temperature range.

Sample Request

[Click Here](#)

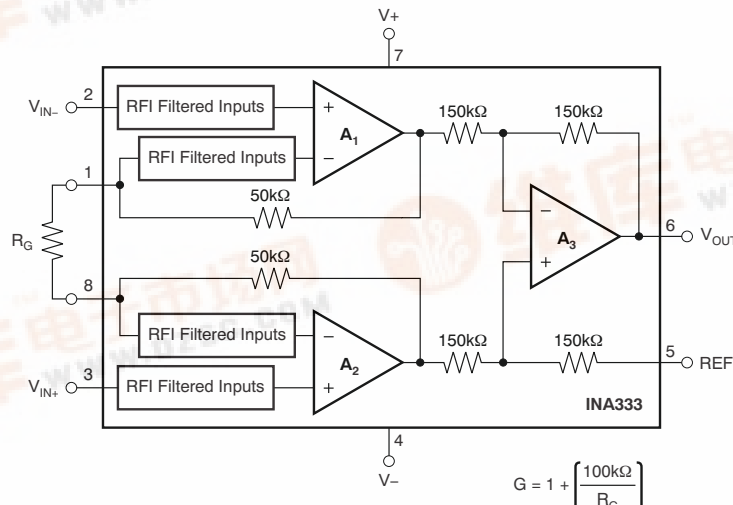

Please be aware that an important notice concerning availability, standard warranty, and use in critical applications of Texas Instruments semiconductor products and disclaimers thereto appears at the end of this data sheet.



This integrated circuit can be damaged by ESD. Texas Instruments recommends that all integrated circuits be handled with appropriate precautions. Failure to observe proper handling and installation procedures can cause damage.

ESD damage can range from subtle performance degradation to complete device failure. Precision integrated circuits may be more susceptible to damage because very small parametric changes could cause the device not to meet its published specifications.

PACKAGE/ORDERING INFORMATION⁽¹⁾

PRODUCT	PACKAGE-LEAD	PACKAGE DESIGNATOR	PACKAGE MARKING
INA333	MSOP-8	DGK	I333
	DFN-8 ⁽²⁾	DRG	I333A

- (1) For the most current package and ordering information see the Package Option Addendum at the end of this document, or see the TI web site at www.ti.com.
- (2) Available Q4, 2008.

ABSOLUTE MAXIMUM RATINGS⁽¹⁾

	INA333	UNIT
Supply voltage	+7	V
Analog input voltage range ⁽²⁾	(V ₋) – 0.3 to (V ₊) + 0.3	V
Output short-circuit ⁽³⁾	Continuous	
Operating temperature range, T _A	–40 to +150	°C
Storage temperature range, T _A	–65 to +150	°C
Junction temperature, T _J	+150	°C
ESD rating	Human body model (HBM)	4000
	Charged device model (CDM)	1000
	Machine model (MM)	200

- (1) Stresses above these ratings may cause permanent damage. Exposure to absolute maximum conditions for extended periods may degrade device reliability. These are stress ratings only, and functional operation of the device at these or any other conditions beyond those specified is not implied.
- (2) Input terminals are diode-clamped to the power-supply rails. Input signals that can swing more than 0.3V beyond the supply rails should be current limited to 10mA or less.
- (3) Short-circuit to ground.

PIN CONFIGURATIONS

**DGK PACKAGE
MSOP-8
(TOP VIEW)**

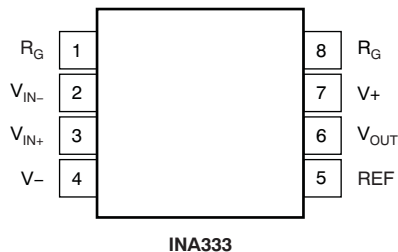

**DRG PACKAGE
DFN-8
(TOP VIEW)**

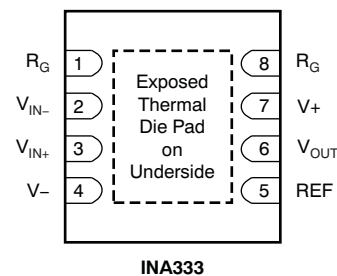

ELECTRICAL CHARACTERISTICS: $V_S = +1.8V$ to $+5.5V$
Boldface limits apply over the specified temperature range, $T_A = -40^{\circ}C$ to $+125^{\circ}C$.

At $T_A = +25^{\circ}C$, $R_L = 10k\Omega$, $V_{REF} = 0$, and $G = 1$, unless otherwise noted.

PARAMETER	TEST CONDITIONS	INA333			UNIT
		MIN	TYP	MAX	
INPUT⁽¹⁾					
Offset voltage, RTI ⁽²⁾ vs Temperature	V_{OSI}		$\pm 10 \pm 25/G$	$\pm 25 \pm 75/G$	μV
vs Power supply	PSR		$\pm 1 \pm 5/G$	$\pm 5 \pm 15/G$	$\mu V/V$
Long-term stability			See note ⁽³⁾		
Turn-on time to specified V_{OSI}			See Typical characteristics		
Impedance					
Differential	Z_{IN}		$100 \parallel 3$		$G\Omega \parallel pF$
Common-mode	Z_{IN}		$100 \parallel 3$		$G\Omega \parallel pF$
Common-mode voltage range	V_{CM}	$V_O = 0V$	$(V-) + 0.1$	$(V+) - 0.1$	V
Common-mode rejection	CMR	DC to 60Hz			
G = 1		$V_{CM} = (V-) + 0.1V$ to $(V+) - 0.1V$	80	90	dB
G = 10		$V_{CM} = (V-) + 0.1V$ to $(V+) - 0.1V$	100	110	dB
G = 100		$V_{CM} = (V-) + 0.1V$ to $(V+) - 0.1V$	100	115	dB
G = 1000		$V_{CM} = (V-) + 0.1V$ to $(V+) - 0.1V$	100	115	dB
INPUT BIAS CURRENT					
Input bias current vs Temperature	I_B		± 70	± 200	pA
			See Typical Characteristic curve		pA^oC
Input offset current vs Temperature	I_{OS}		± 50	± 200	pA
			See Typical Characteristic curve		pA^oC
INPUT VOLTAGE NOISE					
Input voltage noise	e_{NI}	$G = 100, R_S = 0\Omega$			
f = 10Hz			50		nV/\sqrt{Hz}
f = 100Hz			50		nV/\sqrt{Hz}
f = 1kHz			50		nV/\sqrt{Hz}
f = 0.1Hz to 10Hz			1		μV_{PP}
Input current noise	i_N				
f = 10Hz			100		fA/\sqrt{Hz}
f = 0.1Hz to 10Hz			2		pA_{PP}
GAIN					
Gain equation	G		$1 + (100k\Omega/R_G)$		V/V
Range of gain			1	1000	V/V
Gain error		$V_S = 5.5V, (V-) + 100mV \leq V_O \leq (V+) - 100mV$			
G = 1			± 0.01	± 0.1	%
G = 10			± 0.05	± 0.25	%
G = 100			± 0.07	± 0.25	%
G = 1000			± 0.25	± 0.5	%

(1) Total V_{OS} , Referred-to-input = $(V_{OSI}) + (V_{OSO}/G)$.

(2) RTI = Referred-to-input.

(3) 300-hour life test at $+150^{\circ}C$ demonstrated randomly distributed variation of approximately $1\mu V$.

ELECTRICAL CHARACTERISTICS: $V_S = +1.8V$ to $+5.5V$ (continued)

Boldface limits apply over the specified temperature range, $T_A = -40^\circ C$ to $+125^\circ C$.

At $T_A = +25^\circ C$, $R_L = 10k\Omega$, $V_{REF} = 0$, and $G = 1$, unless otherwise noted.

PARAMETER	TEST CONDITIONS	INA333			UNIT
		MIN	TYP	MAX	
GAIN (continued)					
Gain vs Temperature					
G = 1			± 1	± 5	ppm/ $^\circ C$
G > 1⁽⁴⁾			± 15	± 50	ppm/ $^\circ C$
Gain nonlinearity	$V_S = 5.5V, (V-) + 100mV \leq V_O \leq (V+) - 100mV$				
G = 1 to 1000	$R_L = 10k\Omega$		10		ppm
OUTPUT					
Output voltage swing from rail ⁽⁵⁾	$V_S = 5.5V, R_L = 10k\Omega$		See note ⁽⁵⁾	50	mV
Capacitive load drive			500		pF
Short-circuit current	I_{SC} Continuous to common		-40, +5		mA
FREQUENCY RESPONSE					
Bandwidth, -3dB					
G = 1			150		kHz
G = 10			35		kHz
G = 100			3.5		kHz
G = 1000			350		Hz
Slew rate	SR	$V_S = 5V, V_O = 4V$ Step			
G = 1			0.16		V/ μs
G = 100			0.05		V/ μs
Settling time to 0.01%	t_S				
G = 1		$V_{STEP} = 4V$	50		μs
G = 100		$V_{STEP} = 4V$	400		μs
Settling time to 0.001%	t_S				
G = 1		$V_{STEP} = 4V$	60		μs
G = 100		$V_{STEP} = 4V$	500		μs
Overload recovery		50% overdrive	75		μs
REFERENCE INPUT					
R_{IN}			300		k Ω
Voltage range		V-		V+	V
POWER SUPPLY					
Voltage range					
Single		+1.8		+5.5	V
Dual		± 0.9		± 2.75	V
Quiescent current	I_Q	$V_{IN} = V_S/2$	50	75	μA
vs Temperature				80	μA
TEMPERATURE RANGE					
Specified temperature range		-40		+125	$^\circ C$
Operating temperature range		-40		+150	$^\circ C$
Thermal resistance	θ_{JA}				
MSOP			100		$^\circ C/W$
DFN			65		$^\circ C/W$

(4) Does not include effects of external resistor R_G .

(5) See Typical Characteristics curve, *Output Voltage Swing vs Output Current* (Figure 29).

TYPICAL CHARACTERISTICS

At $T_A = +25^\circ\text{C}$, $R_L = 10\text{k}\Omega$, $V_{REF} = 0$, and $G = 1$, unless otherwise noted.

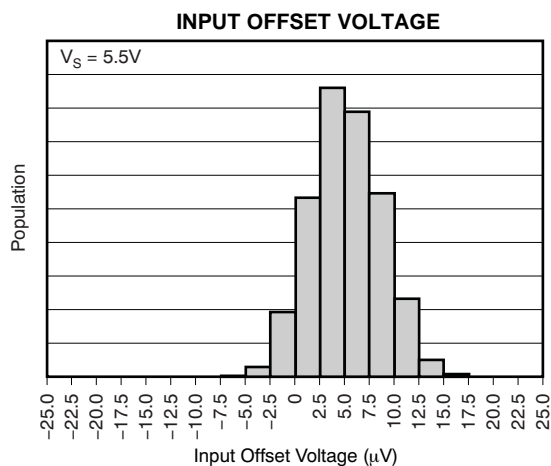

Figure 1.

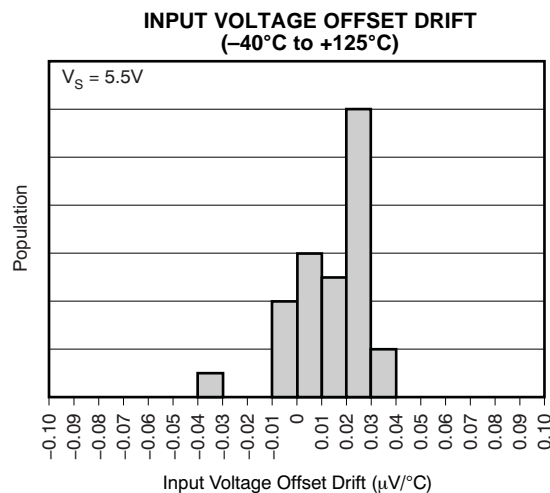

Figure 2.

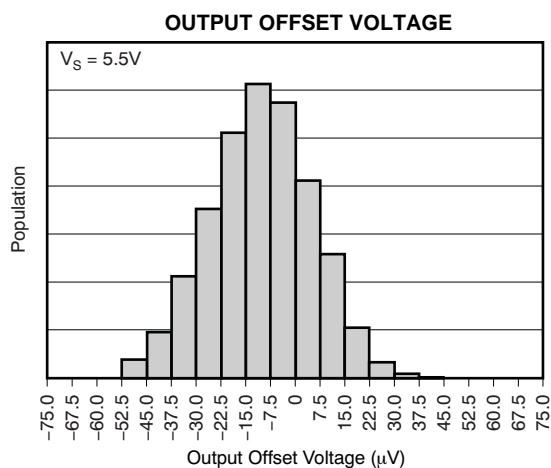

Figure 3.

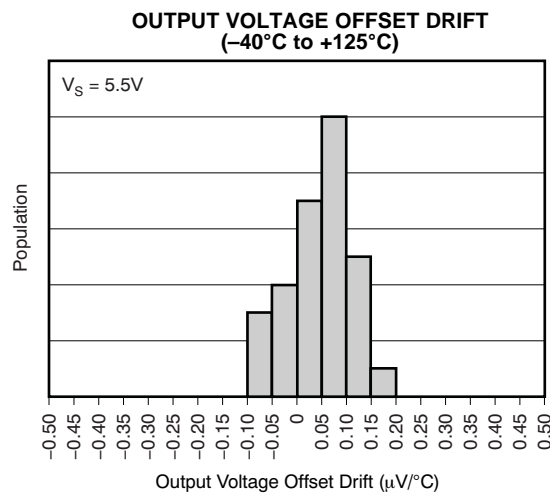

Figure 4.

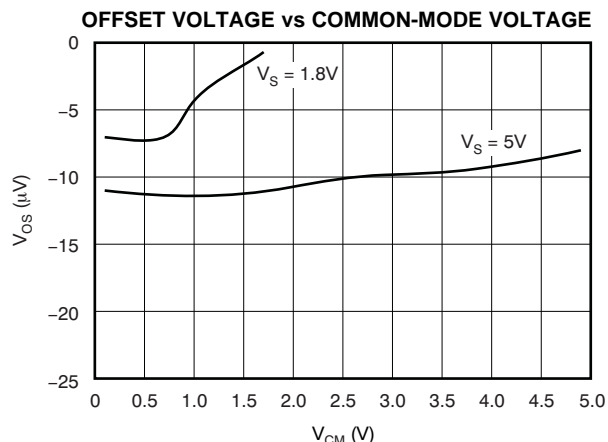

Figure 5.

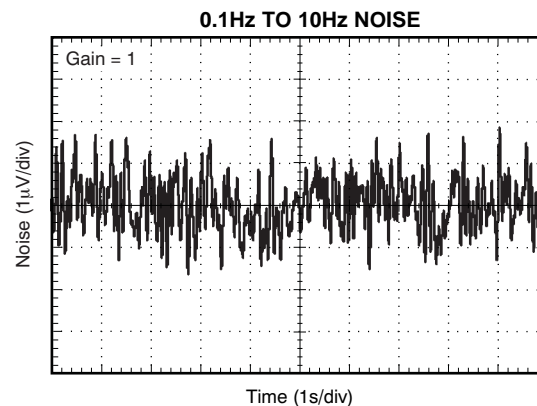

Figure 6.

TYPICAL CHARACTERISTICS (continued)

At $T_A = +25^\circ\text{C}$, $R_L = 10\text{k}\Omega$, $V_{REF} = 0$, and $G = 1$, unless otherwise noted.

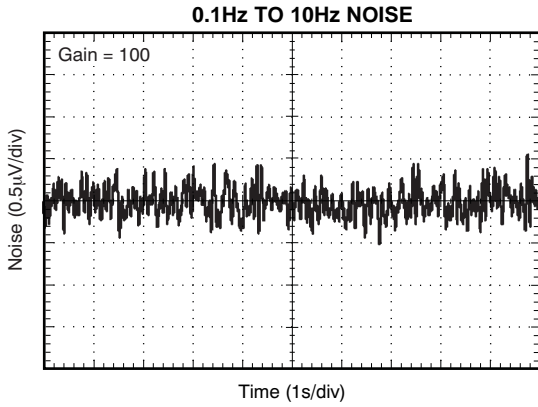

Figure 7.

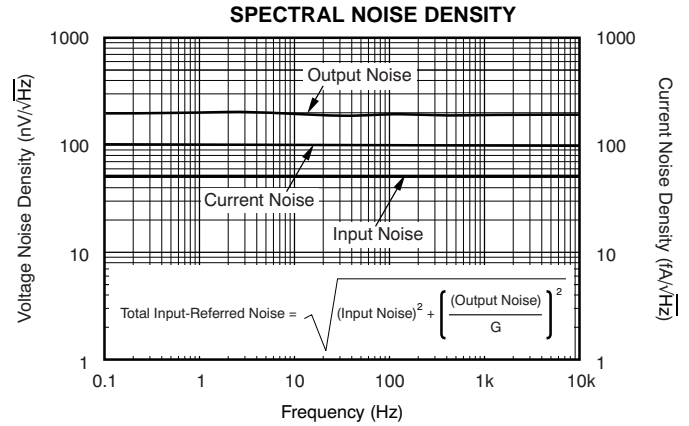

Figure 8.

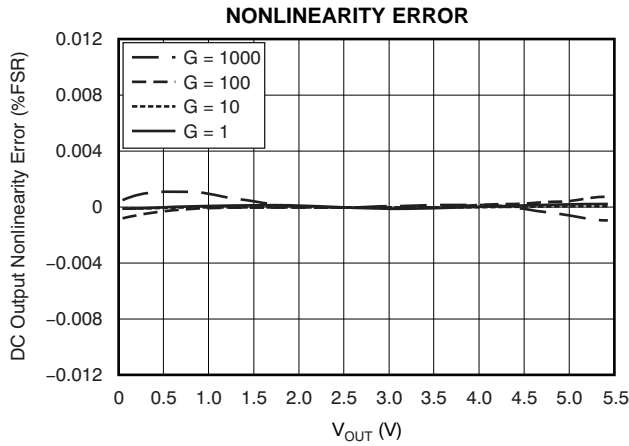

Figure 9.

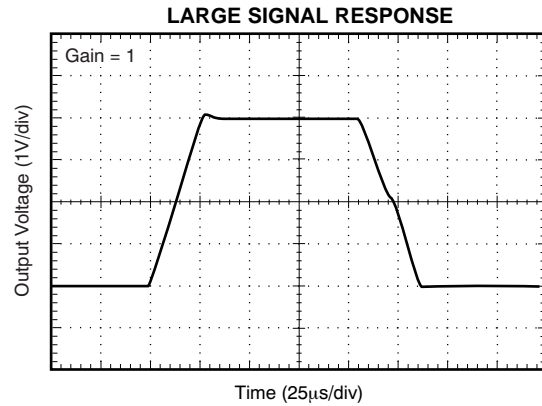

Figure 10.

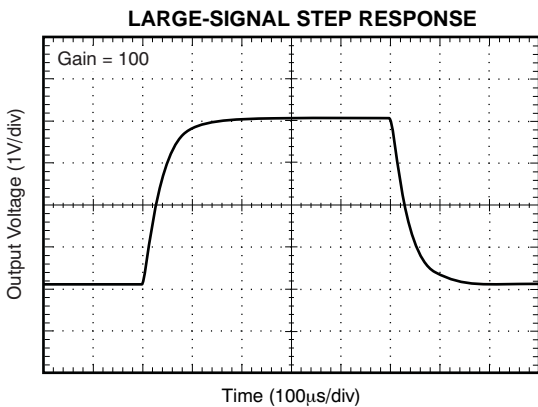

Figure 11.

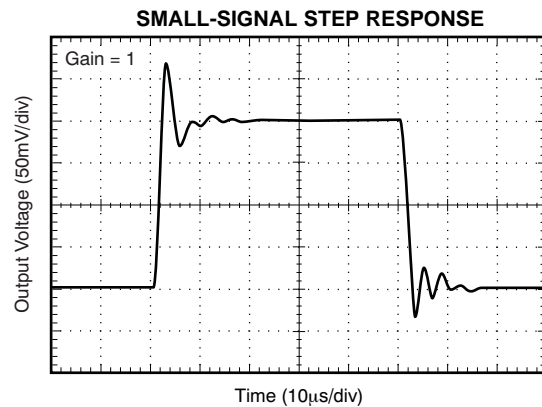

Figure 12.

TYPICAL CHARACTERISTICS (continued)

At $T_A = +25^\circ\text{C}$, $R_L = 10\text{k}\Omega$, $V_{\text{REF}} = 0$, and $G = 1$, unless otherwise noted.

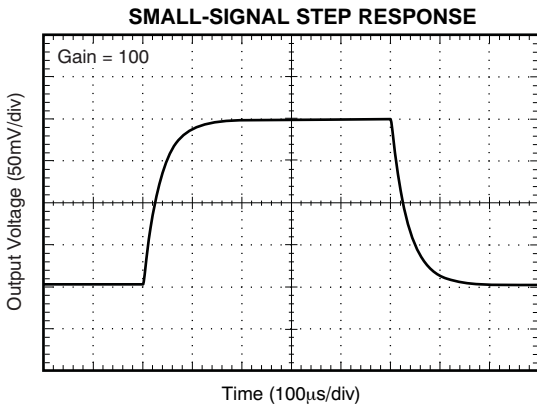

Figure 13.

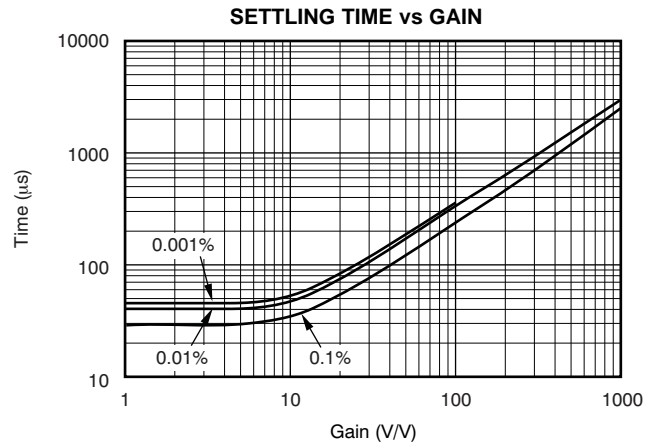

Figure 14.

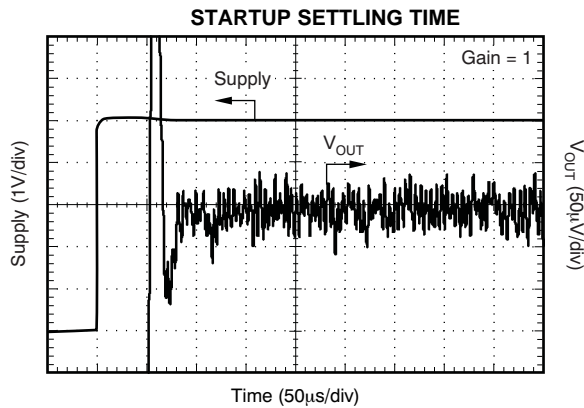

Figure 15.

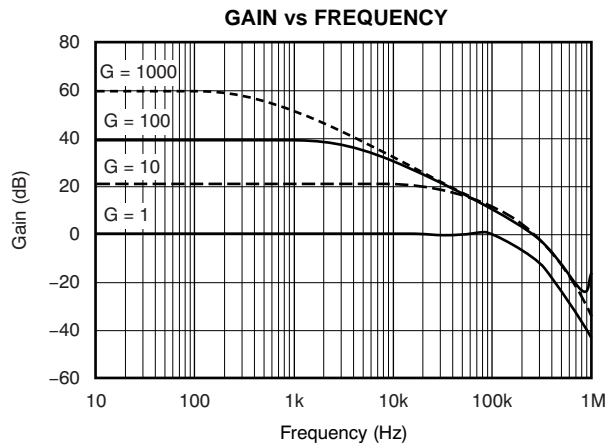

Figure 16.

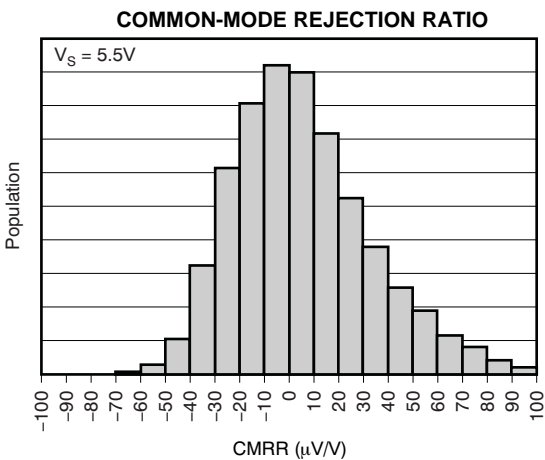

Figure 17.

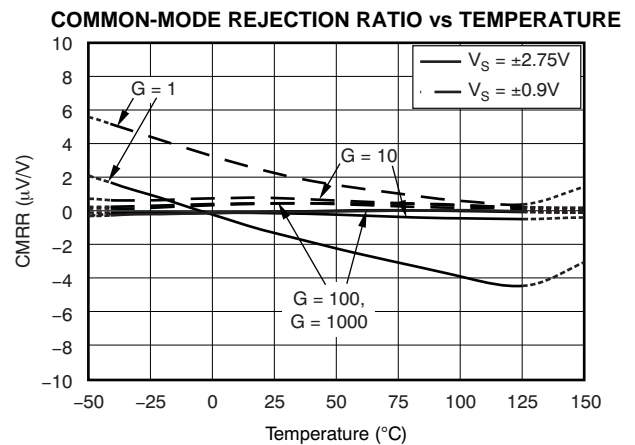

Figure 18.

TYPICAL CHARACTERISTICS (continued)

At $T_A = +25^\circ\text{C}$, $R_L = 10\text{k}\Omega$, $V_{\text{REF}} = 0$, and $G = 1$, unless otherwise noted.

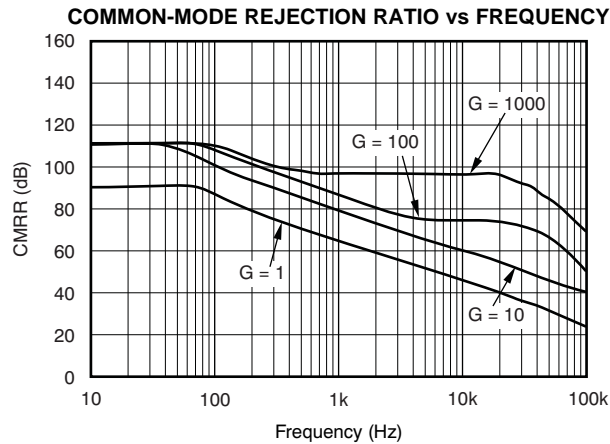

Figure 19.

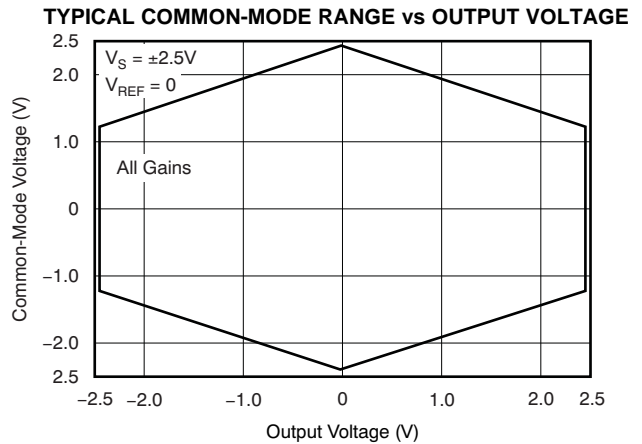

Figure 20.

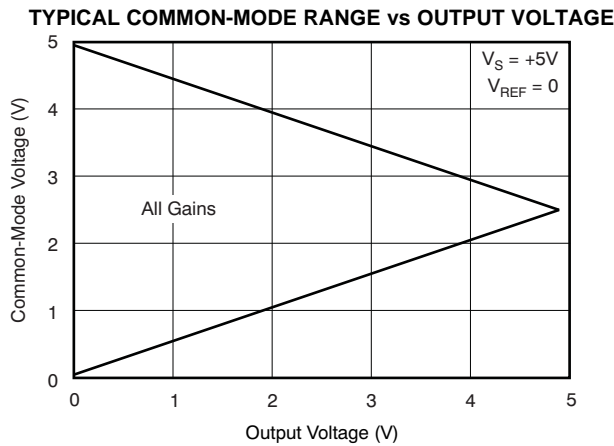

Figure 21.

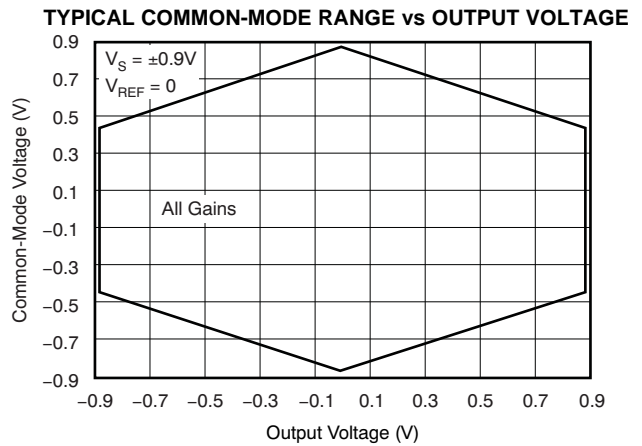

Figure 22.

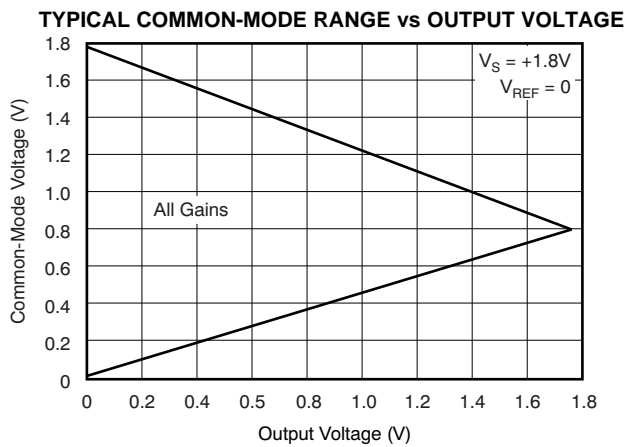

Figure 23.

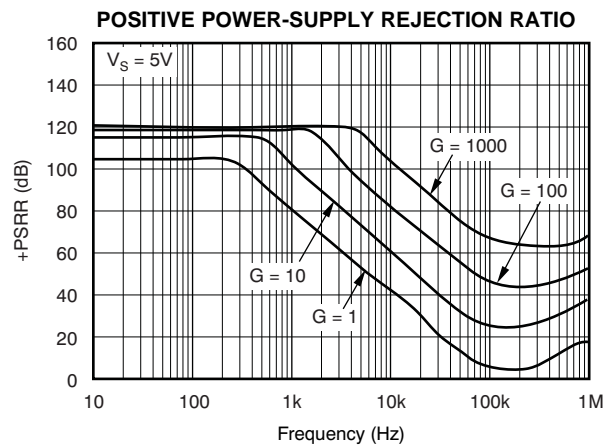

Figure 24.

TYPICAL CHARACTERISTICS (continued)

At $T_A = +25^\circ\text{C}$, $R_L = 10\text{k}\Omega$, $V_{\text{REF}} = 0$, and $G = 1$, unless otherwise noted.

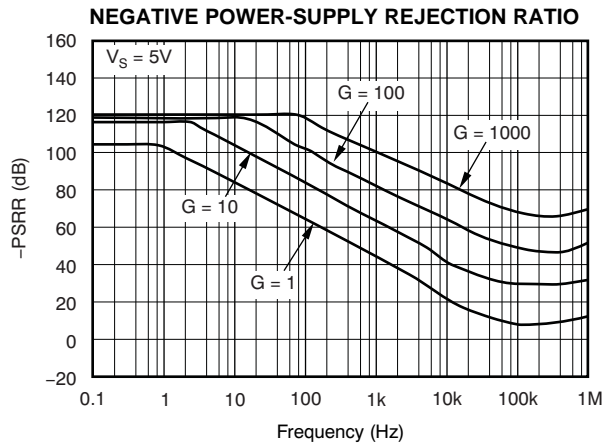

Figure 25.

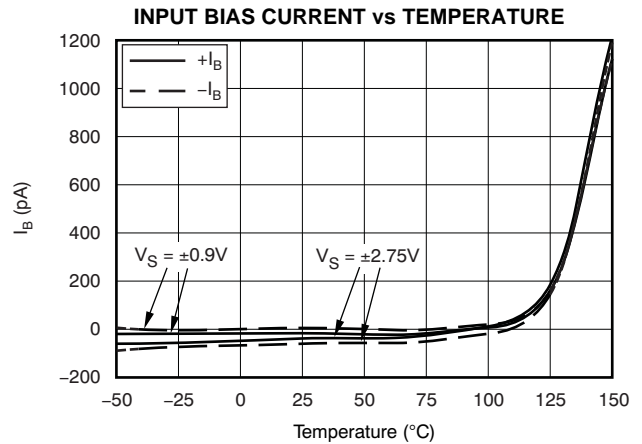

Figure 26.

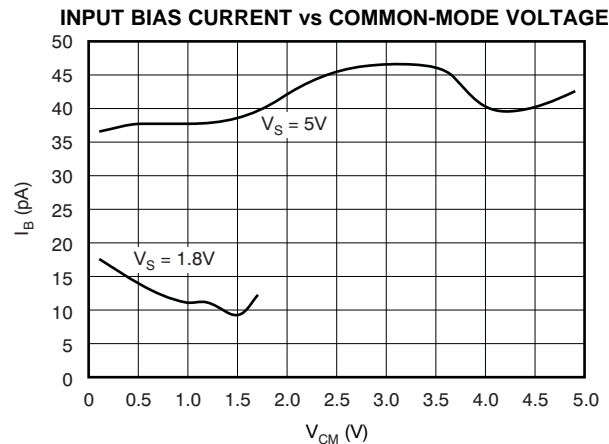

Figure 27.

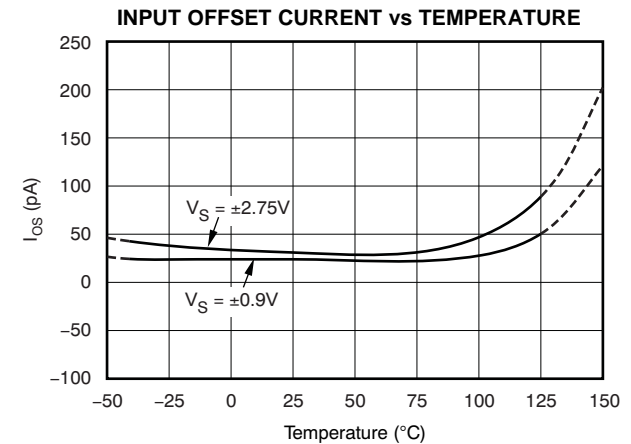

Figure 28.

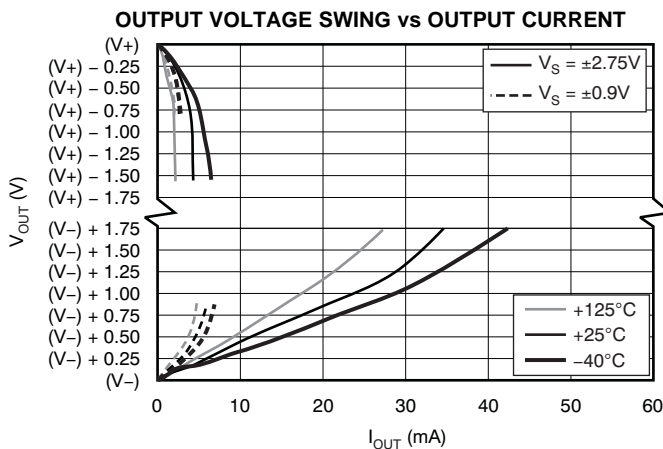

Figure 29.

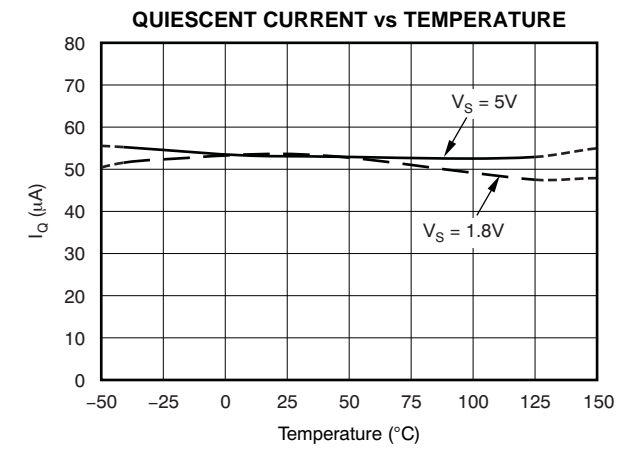

Figure 30.

TYPICAL CHARACTERISTICS (continued)

At $T_A = +25^\circ\text{C}$, $R_L = 10\text{k}\Omega$, $V_{\text{REF}} = 0$, and $G = 1$, unless otherwise noted.

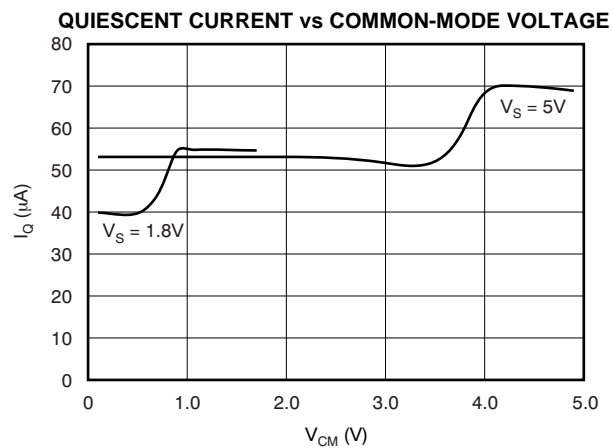

Figure 31.

APPLICATION INFORMATION

Figure 32 shows the basic connections required for operation of the INA333. Good layout practice mandates the use of bypass capacitors placed close to the device pins as shown.

The output of the INA333 is referred to the output reference (REF) terminal, which is normally grounded. This connection must be low-impedance to assure good common-mode rejection. Although 15Ω or less of stray resistance can be tolerated while maintaining specified CMRR, small stray resistances of tens of ohms in series with the REF pin can cause noticeable degradation in CMRR.

SETTING THE GAIN

Gain of the INA333 is set by a single external resistor, R_G , connected between pins 1 and 8. The value of R_G is selected according to Equation 1:

$$G = 1 + (100\text{k}\Omega/R_G) \quad (1)$$

Table 1 lists several commonly-used gains and resistor values. The 100kΩ term in Equation 1 comes from the sum of the two internal feedback resistors of A_1 and A_2 . These on-chip resistors are laser trimmed to accurate absolute values. The accuracy and temperature coefficient of these resistors are included in the gain accuracy and drift specifications of the INA333.

The stability and temperature drift of the external gain setting resistor, R_G , also affects gain. The contribution of R_G to gain accuracy and drift can be directly inferred from the gain Equation 1. Low resistor values required for high gain can make wiring resistance important. Sockets add to the wiring resistance and contribute additional gain error (possibly an unstable gain error) in gains of approximately 100 or greater. To ensure stability, avoid parasitic capacitance of more than a few picofarads at the R_G connections. Careful matching of any parasitics on both R_G pins maintains optimal CMRR over frequency.

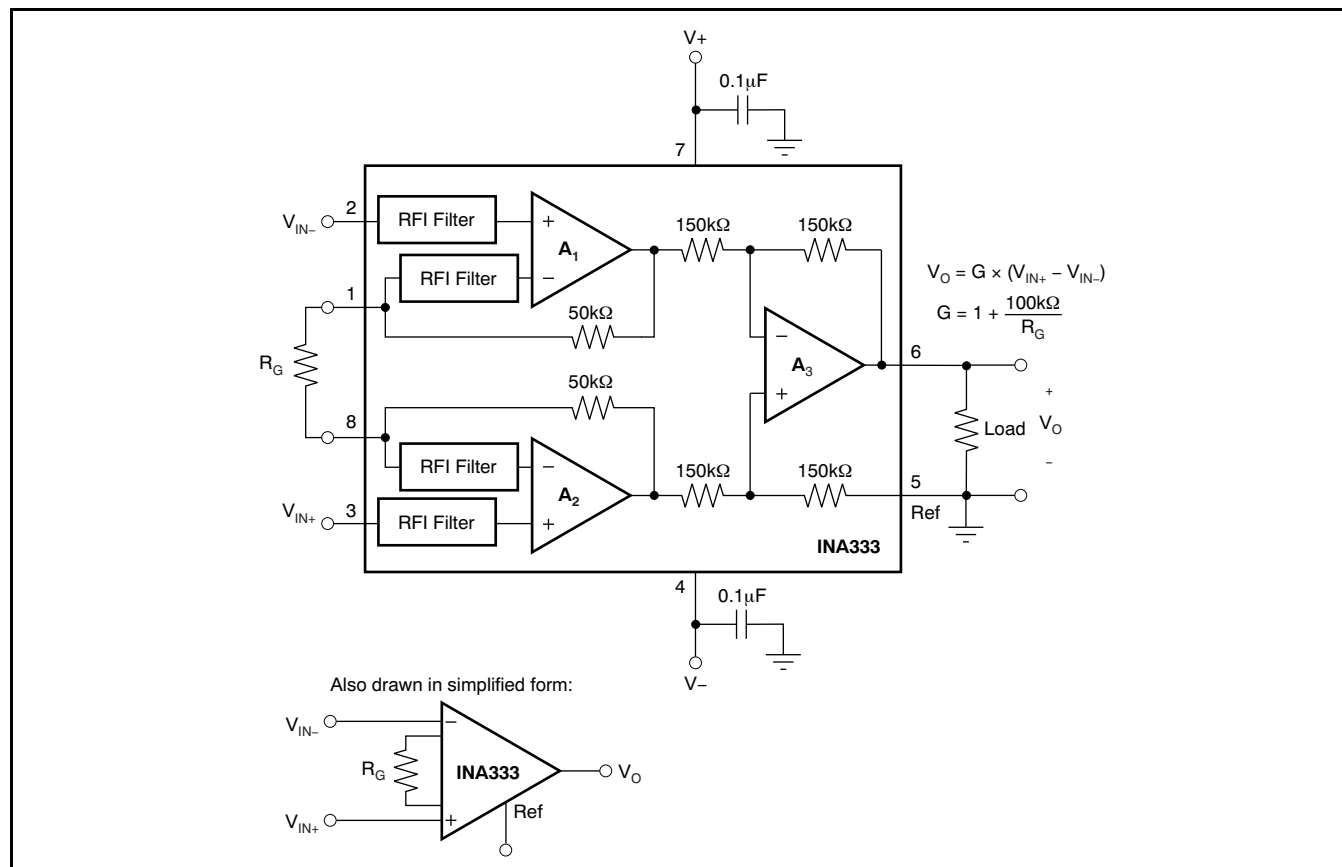

Figure 32. Basic Connections

Table 1. Commonly-Used Gains and Resistor Values

DESIRED GAIN	R _G (Ω)	NEAREST 1% R _G (Ω)
1	NC ⁽¹⁾	NC
2	100k	100k
5	25k	24.9k
10	11.1k	11k
20	5.26k	5.23k
50	2.04k	2.05
100	1.01k	1k
200	502.5	499
500	200.4	200
1000	100.1	100

(1) NC denotes no connection. When using the SPICE model, the simulation will not converge unless a resistor is connected to the R_G pins; use a very large resistor value.

INTERNAL OFFSET CORRECTION

The INA333 internal op amps use an auto-calibration technique with a time-continuous 350kHz op amp in the signal path. The amplifier is zero-corrected every 8μs using a proprietary technique. Upon power-up, the amplifier requires approximately 100μs to achieve specified V_{OS} accuracy. This design has no aliasing or flicker noise.

OFFSET TRIMMING

Most applications require no external offset adjustment; however, if necessary, adjustments can be made by applying a voltage to the REF terminal. Figure 33 shows an optional circuit for trimming the output offset voltage. The voltage applied to REF terminal is summed at the output. The op amp buffer provides low impedance at the REF terminal to preserve good common-mode rejection.

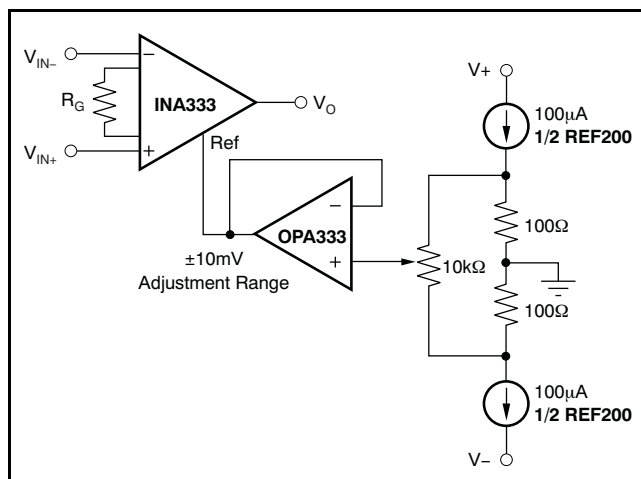

Figure 33. Optional Trimming of Output Offset Voltage

NOISE PERFORMANCE

The auto-calibration technique used by the INA333 results in reduced low frequency noise, typically only 50nV/√Hz, (G = 100). The spectral noise density can be seen in detail in Figure 8. Low frequency noise of the INA333 is approximately 1μV_{PP} measured from 0.1Hz to 10Hz, (G = 100).

INPUT BIAS CURRENT RETURN PATH

The input impedance of the INA333 is extremely high—approximately 100GΩ. However, a path must be provided for the input bias current of both inputs. This input bias current is typically ±70pA. High input impedance means that this input bias current changes very little with varying input voltage.

Input circuitry must provide a path for this input bias current for proper operation. Figure 34 illustrates various provisions for an input bias current path. Without a bias current path, the inputs will float to a potential that exceeds the common-mode range of the INA333, and the input amplifiers will saturate. If the differential source resistance is low, the bias current return path can be connected to one input (see the thermocouple example in Figure 34). With higher source impedance, using two equal resistors provides a balanced input with possible advantages of lower input offset voltage as a result of bias current and better high-frequency common-mode rejection.

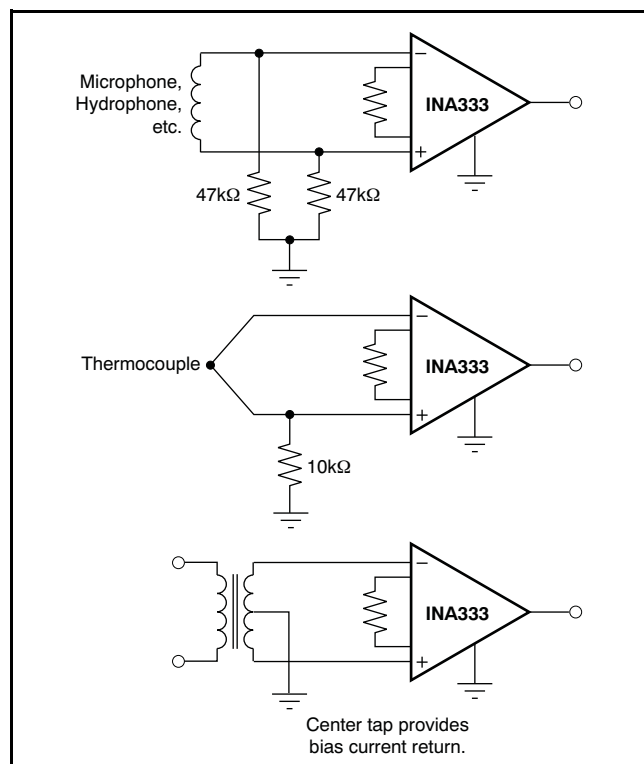

Figure 34. Providing an Input Common-Mode Current Path

INPUT COMMON-MODE RANGE

The linear input voltage range of the input circuitry of the INA333 is from approximately 0.1V below the positive supply voltage to 0.1V above the negative supply. As a differential input voltage causes the output voltage to increase, however, the linear input range is limited by the output voltage swing of amplifiers A_1 and A_2 . Thus, the linear common-mode input range is related to the output voltage of the complete amplifier. This behavior also depends on supply voltage—see Typical Characteristic curves *Typical Common-Mode Range vs Output Voltage* (Figure 20 to Figure 23).

Input overload conditions can produce an output voltage that appears normal. For example, if an input overload condition drives both input amplifiers to the respective positive output swing limit, the difference voltage measured by the output amplifier is near zero. The output of the INA333 is near 0V even though both inputs are overloaded.

OPERATING VOLTAGE

The INA333 operates over a power-supply range of +1.8V to +5.5V ($\pm 0.9V$ to $\pm 2.75V$). Supply voltages higher than +7V (absolute maximum) can permanently damage the device. Parameters that vary over supply voltage or temperature are shown in the [Typical Characteristics](#) section of this data sheet.

LOW VOLTAGE OPERATION

The INA333 can be operated on power supplies as low as $\pm 0.9V$. Most parameters vary only slightly throughout this supply voltage range—see the [Typical Characteristics](#) section. Operation at very low supply voltage requires careful attention to assure that the input voltages remain within the linear range. Voltage swing requirements of internal nodes limit the input common-mode range with low power-supply voltage. The Typical Characteristic curves *Typical Common-Mode Range vs Output Voltage* (Figure 20 to Figure 23) show the range of linear operation for various supply voltages and gains.

SINGLE-SUPPLY OPERATION

The INA333 can be used on single power supplies of +1.8V to +5.5V. Figure 35 illustrates a basic single-supply circuit. The output REF terminal is connected to mid-supply. Zero differential input voltage demands an output voltage of mid-supply. Actual output voltage swing is limited to approximately 50mV above ground, when the load is referred to ground as shown. The typical characteristic curve *Output Voltage Swing vs Output Current* (Figure 29) shows how the output voltage swing varies with output current.

With single-supply operation, V_{IN+} and V_{IN-} must both be 0.1V above ground for linear operation. For instance, the inverting input cannot be connected to ground to measure a voltage connected to the noninverting input.

To illustrate the issues affecting low voltage operation, consider the circuit in Figure 35. It shows the INA333 operating from a single 3V supply. A resistor in series with the low side of the bridge assures that the bridge output voltage is within the common-mode range of the amplifier inputs.

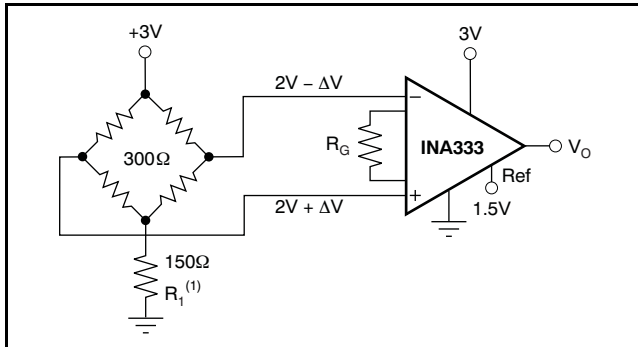

(1) R_1 creates proper common-mode voltage, only for low-voltage operation—see the [Single-Supply Operation](#) section.

Figure 35. Single-Supply Bridge Amplifier

INPUT PROTECTION

The input terminals of the INA333 are protected with internal diodes connected to the power-supply rails. These diodes clamp the applied signal to prevent it from damaging the input circuitry. If the input signal voltage can exceed the power supplies by more than 0.3V, the input signal current should be limited to less than 10mA to protect the internal clamp diodes. This current limiting can generally be done with a series input resistor. Some signal sources are inherently current-limited and do not require limiting resistors.

GENERAL LAYOUT GUIDELINES

Attention to good layout practices is always recommended. Keep traces short and, when possible, use a printed circuit board (PCB) ground plane with surface-mount components placed as close to the device pins as possible. Place a 0.1μF bypass capacitor closely across the supply pins. These guidelines should be applied throughout the analog circuit to improve performance and provide benefits such as reducing the electromagnetic-interference (EMI) susceptibility.

Instrumentation amplifiers vary in the susceptibility to radio-frequency interference (RFI). RFI can generally be identified as a variation in offset voltage or dc signal levels with changes in the interfering RF signal. The INA333 has been specifically designed to minimize susceptibility to RFI by incorporating RFI filters at the V_{IN+} and V_{IN-} inputs. As a result, the INA333 demonstrates remarkably low sensitivity compared to previous generation devices. Strong RF fields may continue to cause varying offset levels, however, and may require additional shielding.

APPLICATION IDEAS

Additional application ideas are shown in [Figure 36](#) to [Figure 39](#).

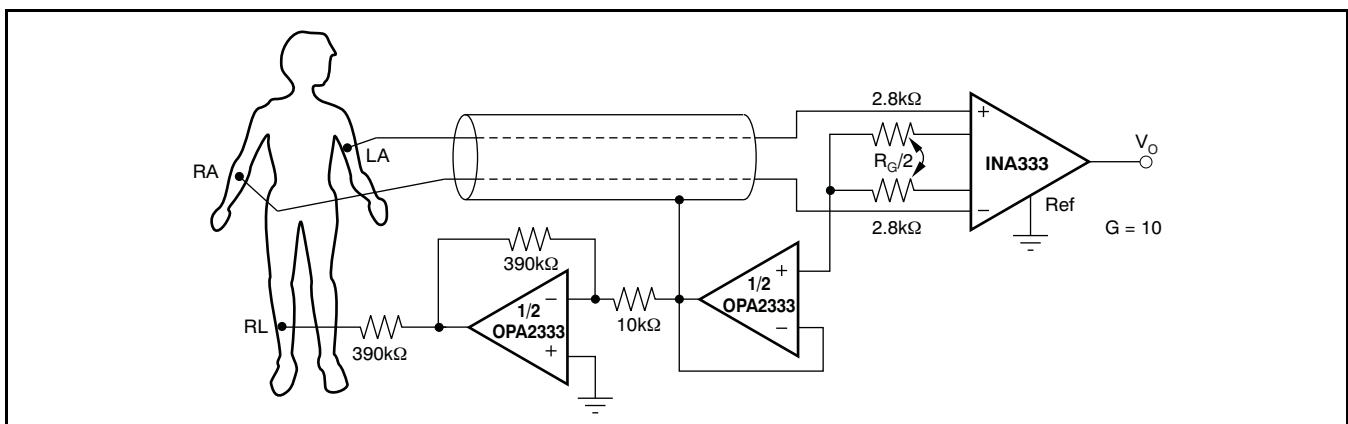

Figure 36. ECG Amplifier With Right-Leg Drive

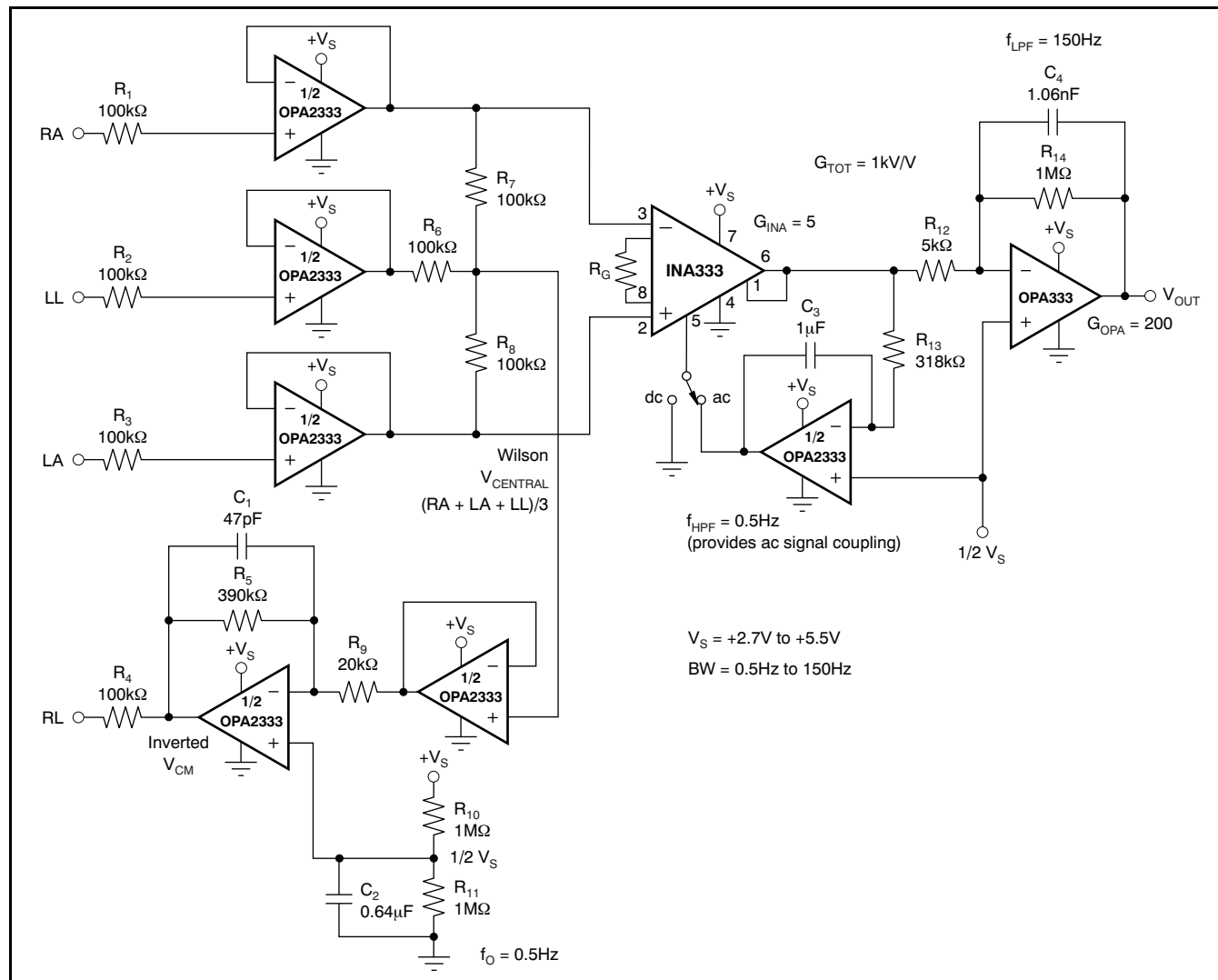

Figure 37. Single-Supply, Very Low Power, ECG Circuit

**TINA-TI
(FREE DOWNLOAD SOFTWARE)**

Using TINA-TI SPICE-Based Analog Simulation Program with the INA333

TINA is a simple, powerful, and easy-to-use circuit simulation program based on a SPICE engine. TINA-TI is a free, fully functional version of the TINA software, preloaded with a library of macromodels in addition to a range of both passive and active models. It provides all the conventional dc, transient, and frequency domain analysis of SPICE as well as additional design capabilities.

Available as a free download from the [Analog eLab Design Center](#), TINA-TI offers extensive post-processing capability that allows users to format results in a variety of ways.

Virtual instruments offer users the ability to select input waveforms and probe circuit nodes, voltages, and waveforms, creating a dynamic quick-start tool.

Figure 38 and Figure 39 show example TINA-TI circuits for the INA333 that can be used to develop, modify, and assess the circuit design for specific applications. Links to download these simulation files are given below.

NOTE: these files require that either the TINA software (from DesignSoft) or TINA-TI software be installed. Download the free TINA-TI software from the [TINA-TI folder](#).

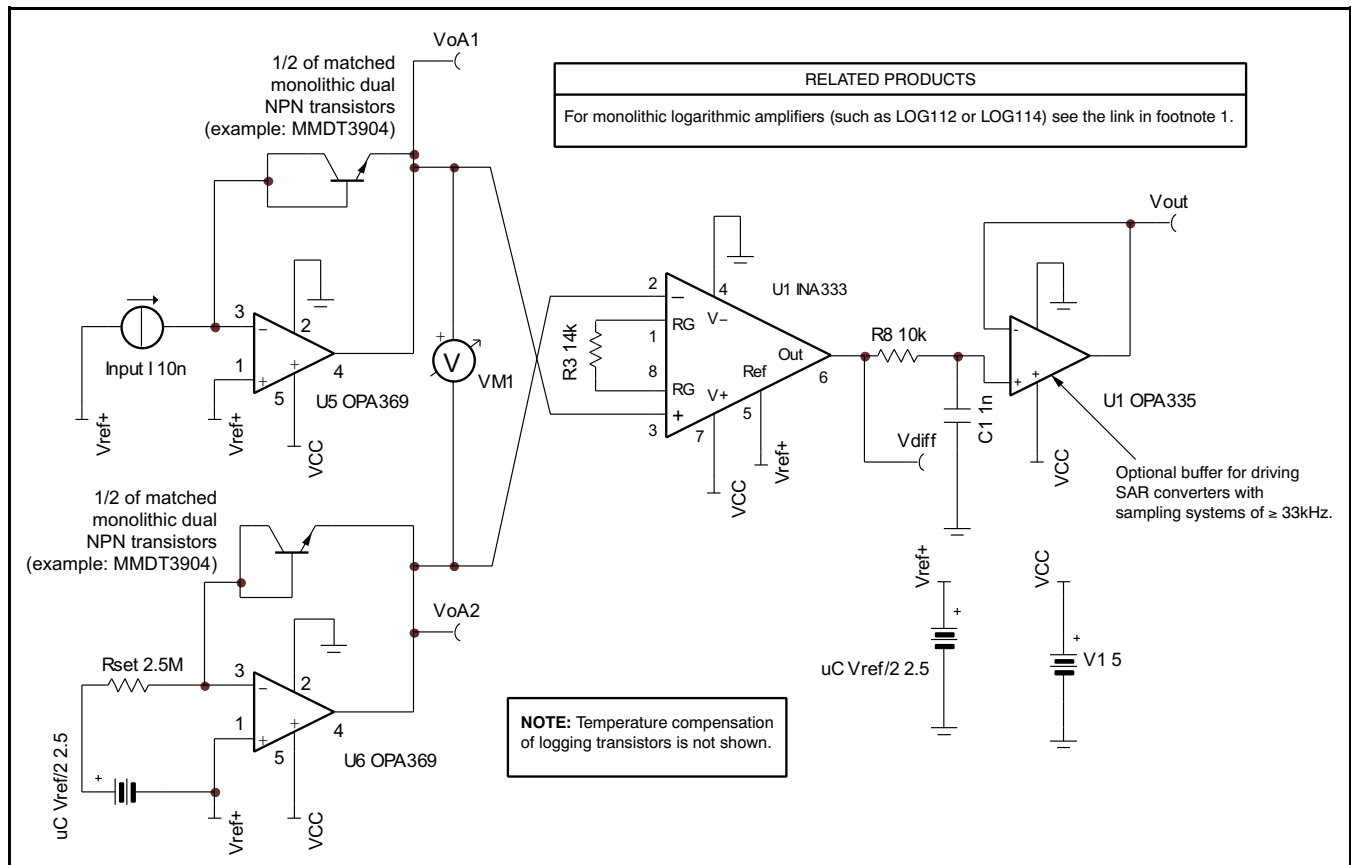

(1) The following link launches the TI logarithmic amplifiers web page: [Logarithmic Amplifier Products Home Page](#)

Figure 38. Low-Power Log Function Circuit for Portable Battery-Powered Systems (Example Glucose Meter)

To download a compressed file that contains the TINA-TI simulation file for this circuit, click the following link: [Log Circuit](#).

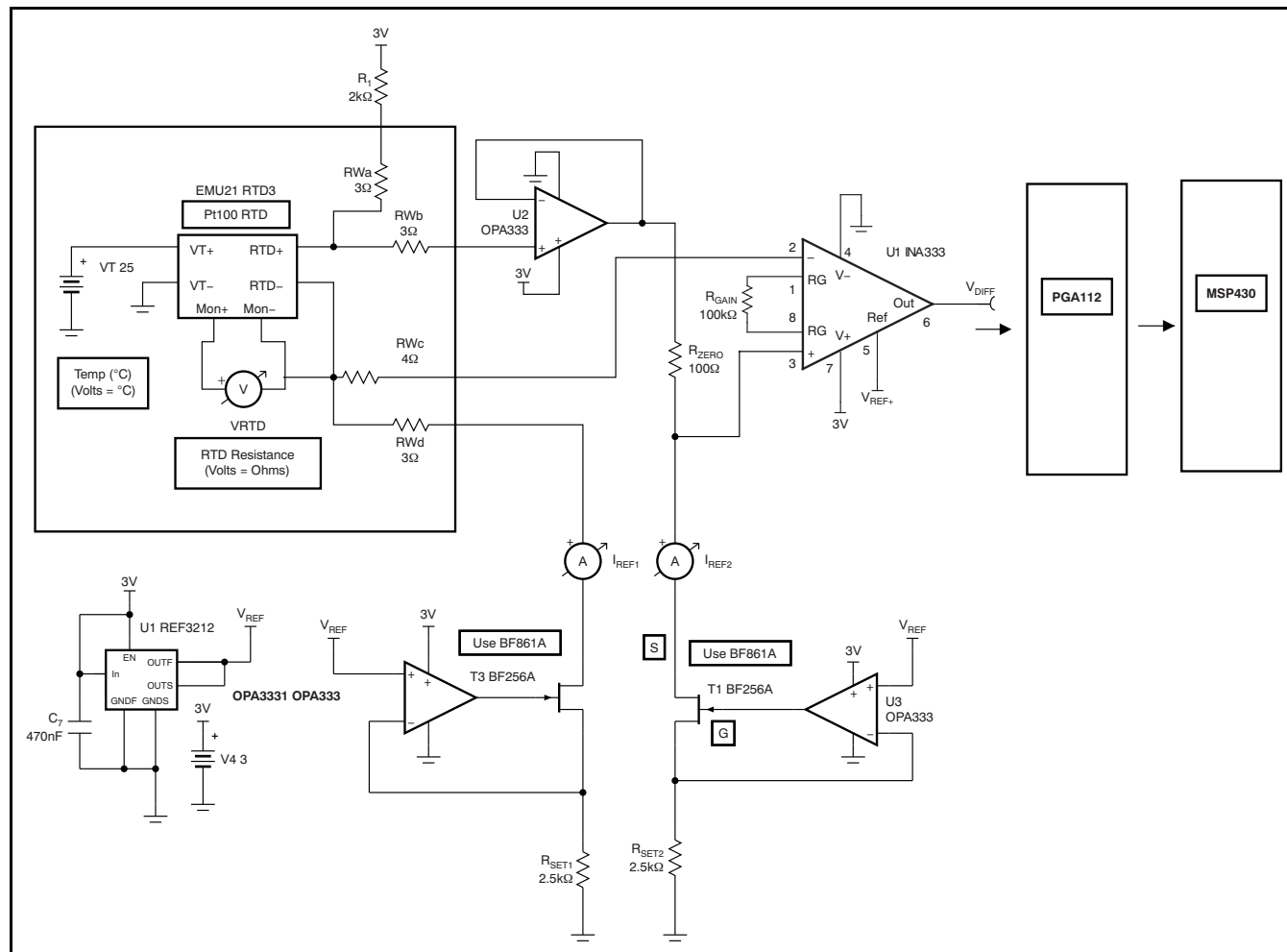

RWa, RWb, RWc, and RWd simulate wire resistance. These resistors are included to show the four-wire sense technique immunity to line mismatches. This method assumes the use of a four-wire RTD.

Figure 39. Four-Wire, 3V Conditioner for a PT100 RTD With Programmable Gain Acquisition System

To download a compressed file that contains the TINA-TI simulation file for this circuit, click the following link: [PT100 RTD](#).

PACKAGING INFORMATION

Orderable Device	Status ⁽¹⁾	Package Type	Package Drawing	Pins	Package Qty	Eco Plan ⁽²⁾	Lead/Ball Finish	MSL Peak Temp ⁽³⁾
INA333AIDGKR	ACTIVE	MSOP	DGK	8	2500	Green (RoHS & no Sb/Br)	CU NIPDAU	Level-2-260C-1 YEAR
INA333AIDGKT	ACTIVE	MSOP	DGK	8	250	Green (RoHS & no Sb/Br)	CU NIPDAU	Level-2-260C-1 YEAR
INA333AIDRGR	PREVIEW	SON	DRG	8	1000	TBD	Call TI	Call TI
INA333AIDRGT	PREVIEW	SON	DRG	8	250	TBD	Call TI	Call TI

⁽¹⁾ The marketing status values are defined as follows:

ACTIVE: Product device recommended for new designs.

LIFEBUY: TI has announced that the device will be discontinued, and a lifetime-buy period is in effect.

NRND: Not recommended for new designs. Device is in production to support existing customers, but TI does not recommend using this part in a new design.

PREVIEW: Device has been announced but is not in production. Samples may or may not be available.

OBSOLETE: TI has discontinued the production of the device.

⁽²⁾ Eco Plan - The planned eco-friendly classification: Pb-Free (RoHS), Pb-Free (RoHS Exempt), or Green (RoHS & no Sb/Br) - please check <http://www.ti.com/productcontent> for the latest availability information and additional product content details.

TBD: The Pb-Free/Green conversion plan has not been defined.

Pb-Free (RoHS): TI's terms "Lead-Free" or "Pb-Free" mean semiconductor products that are compatible with the current RoHS requirements for all 6 substances, including the requirement that lead not exceed 0.1% by weight in homogeneous materials. Where designed to be soldered at high temperatures, TI Pb-Free products are suitable for use in specified lead-free processes.

Pb-Free (RoHS Exempt): This component has a RoHS exemption for either 1) lead-based flip-chip solder bumps used between the die and package, or 2) lead-based die adhesive used between the die and leadframe. The component is otherwise considered Pb-Free (RoHS compatible) as defined above.

Green (RoHS & no Sb/Br): TI defines "Green" to mean Pb-Free (RoHS compatible), and free of Bromine (Br) and Antimony (Sb) based flame retardants (Br or Sb do not exceed 0.1% by weight in homogeneous material)

⁽³⁾ MSL, Peak Temp. -- The Moisture Sensitivity Level rating according to the JEDEC industry standard classifications, and peak solder temperature.

Important Information and Disclaimer:The information provided on this page represents TI's knowledge and belief as of the date that it is provided. TI bases its knowledge and belief on information provided by third parties, and makes no representation or warranty as to the accuracy of such information. Efforts are underway to better integrate information from third parties. TI has taken and continues to take reasonable steps to provide representative and accurate information but may not have conducted destructive testing or chemical analysis on incoming materials and chemicals. TI and TI suppliers consider certain information to be proprietary, and thus CAS numbers and other limited information may not be available for release.

In no event shall TI's liability arising out of such information exceed the total purchase price of the TI part(s) at issue in this document sold by TI to Customer on an annual basis.

TAPE AND REEL INFORMATION

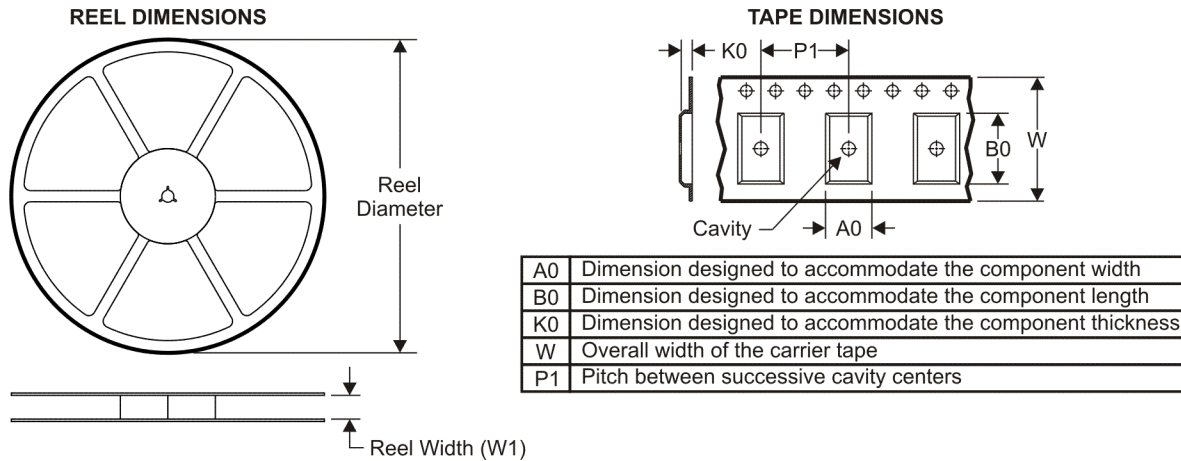

QUADRANT ASSIGNMENTS FOR PIN 1 ORIENTATION IN TAPE

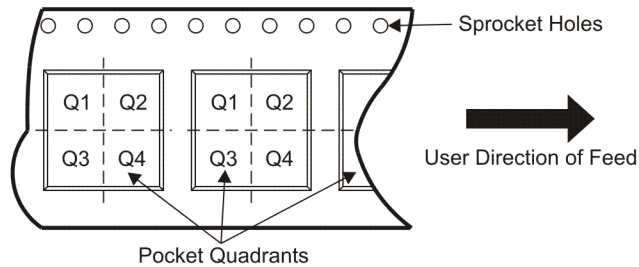

*All dimensions are nominal

Device	Package Type	Package Drawing	Pins	SPQ	Reel Diameter (mm)	Reel Width W1 (mm)	A0 (mm)	B0 (mm)	K0 (mm)	P1 (mm)	W (mm)	Pin1 Quadrant
INA333AIDGKR	MSOP	DGK	8	2500	330.0	12.4	5.3	3.3	1.3	8.0	12.0	Q1
INA333AIDGKT	MSOP	DGK	8	250	330.0	12.4	5.3	3.3	1.3	8.0	12.0	Q1

TAPE AND REEL BOX DIMENSIONS

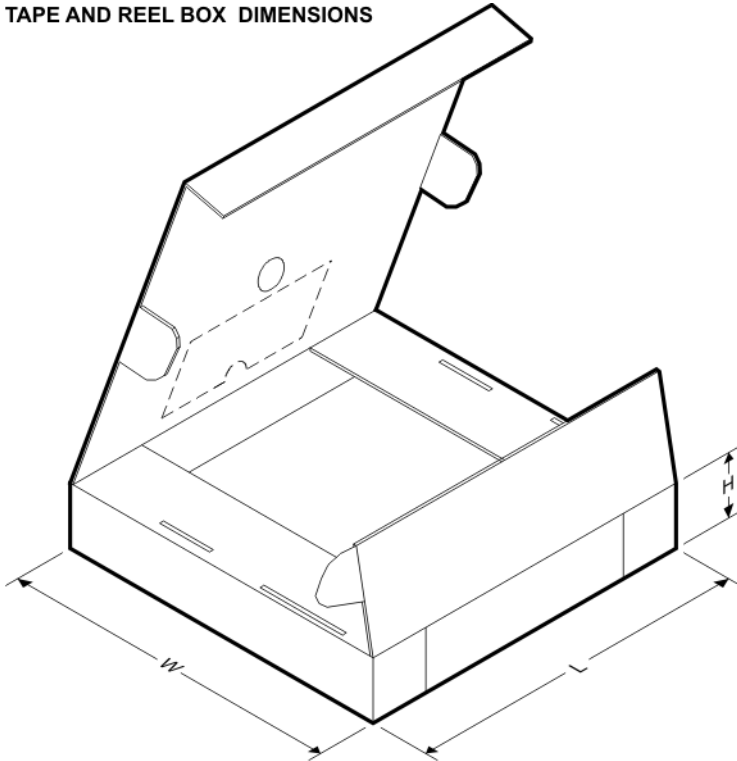

*All dimensions are nominal

Device	Package Type	Package Drawing	Pins	SPQ	Length (mm)	Width (mm)	Height (mm)
INA333AIDGKR	MSOP	DGK	8	2500	370.0	355.0	55.0
INA333AIDGKT	MSOP	DGK	8	250	370.0	355.0	55.0

MECHANICAL DATA

DGK (S-PDSO-G8)

PLASTIC SMALL-OUTLINE PACKAGE

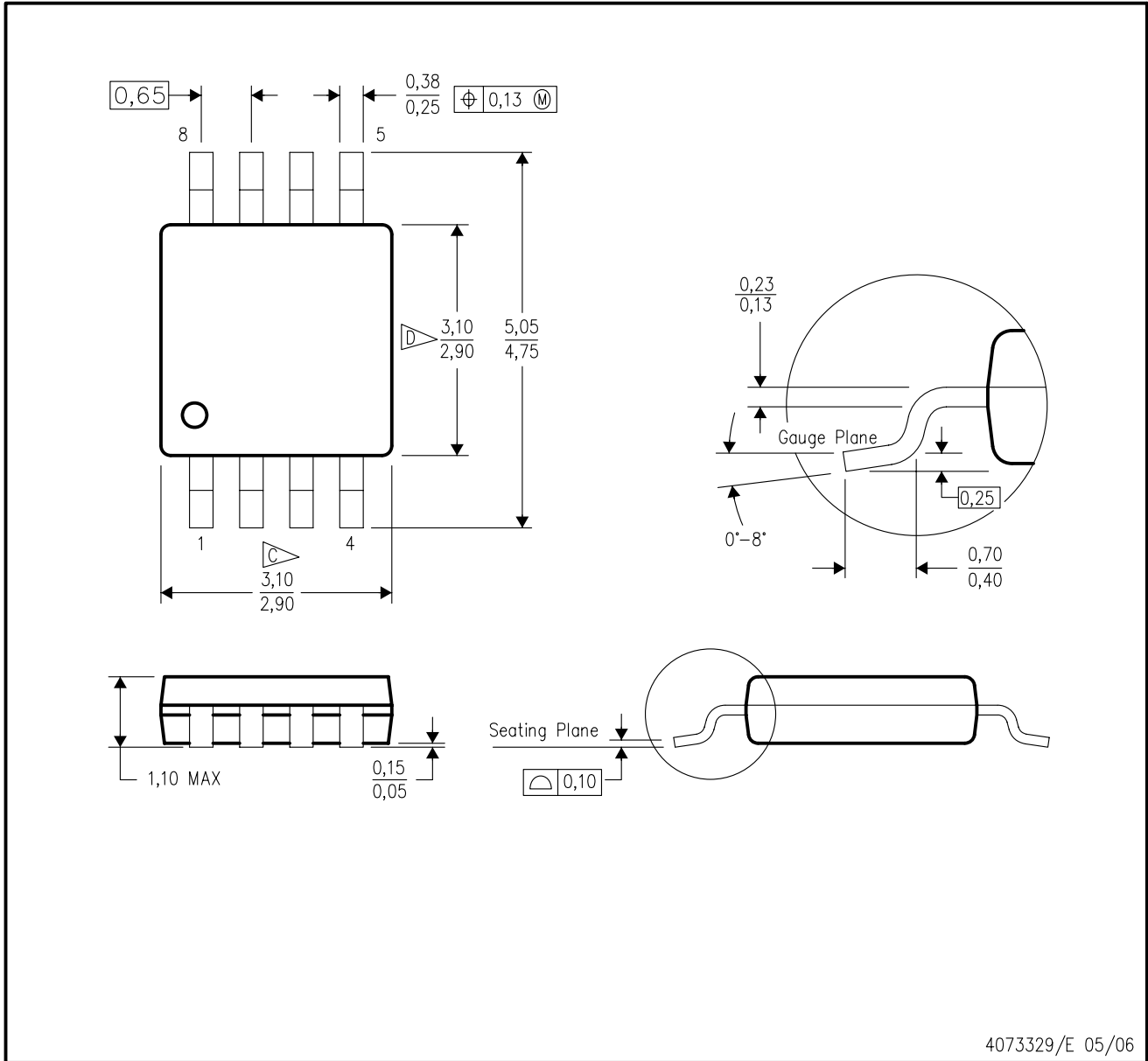

- NOTES:
- A. All linear dimensions are in millimeters.
 - B. This drawing is subject to change without notice.
 - C. Body length does not include mold flash, protrusions, or gate burrs. Mold flash, protrusions, or gate burrs shall not exceed 0.15 per end.
 - D. Body width does not include interlead flash. Interlead flash shall not exceed 0.50 per side.
 - E. Falls within JEDEC MO-187 variation AA, except interlead flash.

MECHANICAL DATA

DRG (S-PDSO-N8)

PLASTIC SMALL OUTLINE

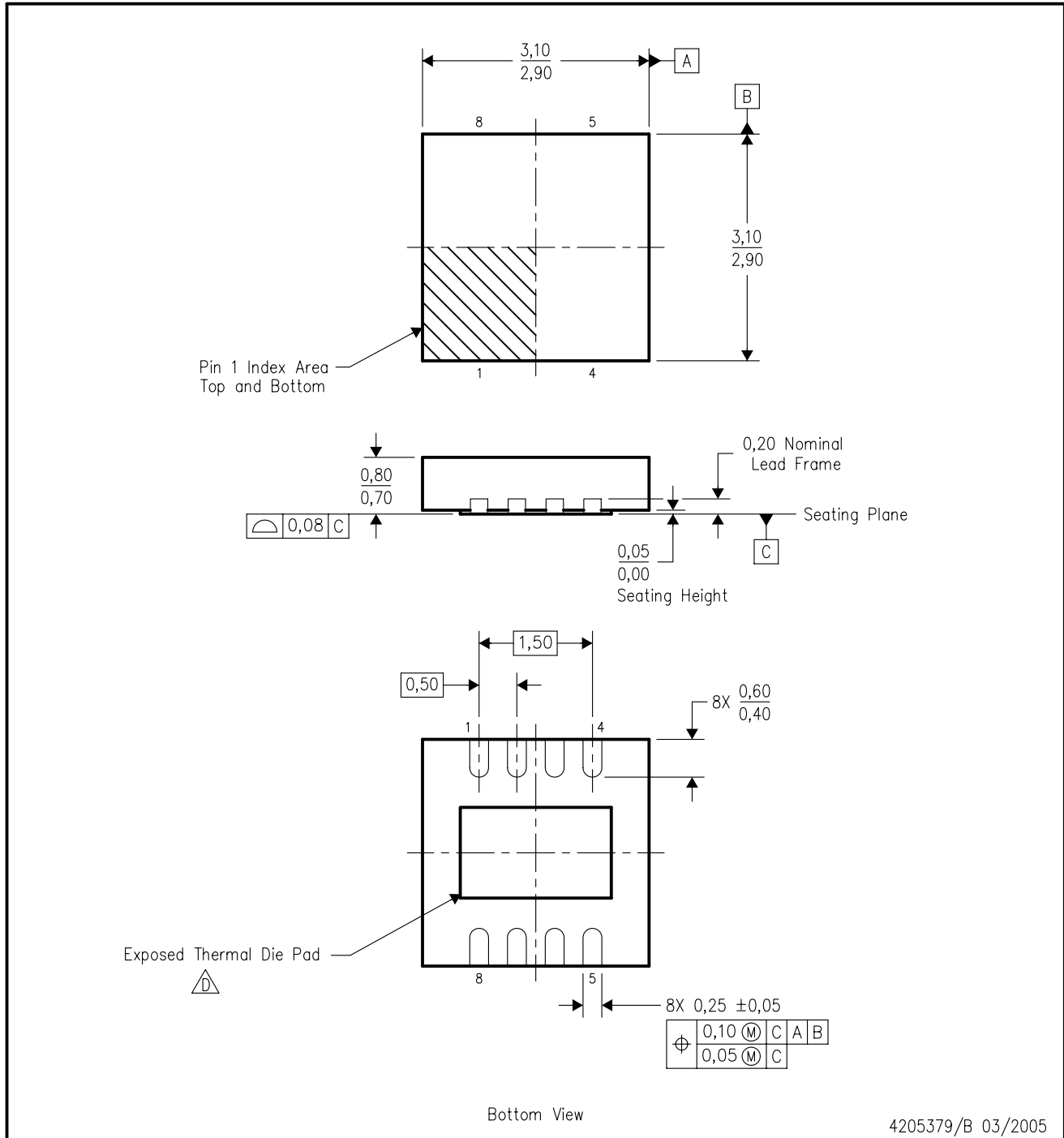

4205379/B 03/2005

- NOTES:
- All linear dimensions are in millimeters. Dimensioning and tolerancing per ASME Y14.5M-1994.
 - This drawing is subject to change without notice.
 - SON (Small Outline No-Lead) package configuration.
 - The package thermal pad must be soldered to the board for thermal and mechanical performance. See the Product Data Sheet for details regarding the exposed thermal pad dimensions.
 - JEDEC MO-229 package registration pending.

IMPORTANT NOTICE

Texas Instruments Incorporated and its subsidiaries (TI) reserve the right to make corrections, modifications, enhancements, improvements, and other changes to its products and services at any time and to discontinue any product or service without notice. Customers should obtain the latest relevant information before placing orders and should verify that such information is current and complete. All products are sold subject to TI's terms and conditions of sale supplied at the time of order acknowledgment.

TI warrants performance of its hardware products to the specifications applicable at the time of sale in accordance with TI's standard warranty. Testing and other quality control techniques are used to the extent TI deems necessary to support this warranty. Except where mandated by government requirements, testing of all parameters of each product is not necessarily performed.

TI assumes no liability for applications assistance or customer product design. Customers are responsible for their products and applications using TI components. To minimize the risks associated with customer products and applications, customers should provide adequate design and operating safeguards.

TI does not warrant or represent that any license, either express or implied, is granted under any TI patent right, copyright, mask work right, or other TI intellectual property right relating to any combination, machine, or process in which TI products or services are used. Information published by TI regarding third-party products or services does not constitute a license from TI to use such products or services or a warranty or endorsement thereof. Use of such information may require a license from a third party under the patents or other intellectual property of the third party, or a license from TI under the patents or other intellectual property of TI.

Reproduction of TI information in TI data books or data sheets is permissible only if reproduction is without alteration and is accompanied by all associated warranties, conditions, limitations, and notices. Reproduction of this information with alteration is an unfair and deceptive business practice. TI is not responsible or liable for such altered documentation. Information of third parties may be subject to additional restrictions.

Resale of TI products or services with statements different from or beyond the parameters stated by TI for that product or service voids all express and any implied warranties for the associated TI product or service and is an unfair and deceptive business practice. TI is not responsible or liable for any such statements.

TI products are not authorized for use in safety-critical applications (such as life support) where a failure of the TI product would reasonably be expected to cause severe personal injury or death, unless officers of the parties have executed an agreement specifically governing such use. Buyers represent that they have all necessary expertise in the safety and regulatory ramifications of their applications, and acknowledge and agree that they are solely responsible for all legal, regulatory and safety-related requirements concerning their products and any use of TI products in such safety-critical applications, notwithstanding any applications-related information or support that may be provided by TI. Further, Buyers must fully indemnify TI and its representatives against any damages arising out of the use of TI products in such safety-critical applications.

TI products are neither designed nor intended for use in military/aerospace applications or environments unless the TI products are specifically designated by TI as military-grade or "enhanced plastic." Only products designated by TI as military-grade meet military specifications. Buyers acknowledge and agree that any such use of TI products which TI has not designated as military-grade is solely at the Buyer's risk, and that they are solely responsible for compliance with all legal and regulatory requirements in connection with such use.

TI products are neither designed nor intended for use in automotive applications or environments unless the specific TI products are designated by TI as compliant with ISO/TS 16949 requirements. Buyers acknowledge and agree that, if they use any non-designated products in automotive applications, TI will not be responsible for any failure to meet such requirements.

Following are URLs where you can obtain information on other Texas Instruments products and application solutions:

Products		Applications	
Amplifiers	amplifier.ti.com	Audio	www.ti.com/audio
Data Converters	dataconverter.ti.com	Automotive	www.ti.com/automotive
DSP	dsp.ti.com	Broadband	www.ti.com/broadband
Clocks and Timers	www.ti.com/clocks	Digital Control	www.ti.com/digitalcontrol
Interface	interface.ti.com	Medical	www.ti.com/medical
Logic	logic.ti.com	Military	www.ti.com/military
Power Mgmt	power.ti.com	Optical Networking	www.ti.com/opticalnetwork
Microcontrollers	microcontroller.ti.com	Security	www.ti.com/security
RFID	www.ti.com/rfid.com	Telephony	www.ti.com/telephony
RF/IF and ZigBee® Solutions	www.ti.com/lprf	Video & Imaging	www.ti.com/video
		Wireless	www.ti.com/wireless

Mailing Address: Texas Instruments, Post Office Box 655303, Dallas, Texas 75265
Copyright © 2008, Texas Instruments Incorporated