

## Dual Channel Sensorless Motor Control IC for Appliances

### Features

- **MCE™ (Motion Control Engine) - Hardware based computation engine for high efficiency sinusoidal sensorless control of permanent magnet AC motor**
- **Integrated Power Factor Correction control**
- **Supports both interior and surface permanent magnet motors**
- **Built-in hardware peripheral for single shunt current feedback reconstruction**
- **No external current or voltage sensing operational amplifier required**
- **Dual channel three/two-phase Space Vector PWM**
- **Two-channel analog output (PWM)**
- **Embedded 8-bit high speed microcontroller (8051) for flexible I/O and man-machine control**
- **JTAG programming port for emulation/debugger**
- **Two serial communication interface (UART)**
- **I<sup>2</sup>C/SPI serial interface**
- **Watchdog timer with independent analog clock**
- **Three general purpose timers**
- **Two special timers: periodic timer, capture timer**
- **External EEPROM and internal RAM facilitate debugging and code development**
- **Pin compatible with IRMCK311, OTP-ROM version**
- **1.8V/3.3V CMOS**

### Product Summary

Maximum crystal frequency	60 MHz
Maximum internal clock (SYSCLK) frequency	128 MHz
Sensorless control computation time	11 μsec typ
MCE™ computation data range	16 bit signed
Program RAM loaded from external EEPROM	48K bytes
Data RAM	8K bytes
GateKill latency (digital filtered)	2 μsec
PWM carrier frequency counter	16 bits/ SYSCLK
A/D input channels	6
A/D converter resolution	12 bits
A/D converter conversion speed	2 μsec
8051 instruction execution speed	2 SYSCLK
Analog output (PWM) resolution	8 bits
UART baud rate (typ)	57.6K bps
Number of I/O (max)	14
Package (lead-free)	QFP64

### Description

IRMCF311 is a high performance RAM based motion control IC designed primarily for appliance applications. IRMCF311 is designed to achieve low cost and high performance control solutions for advanced inverterized appliance motor control. IRMCF311 contains two computation engines. One is Motion Control Engine (MCE™) for sensorless control of permanent magnet motors; the other is an 8-bit high-speed microcontroller (8051). Both computation engines are integrated into one monolithic chip. The MCE™ contains a collection of control elements such as Proportional plus Integral, Vector rotator, Angle estimator, Multiply/Divide, Low loss SVPWM, Single Shunt IFB. The user can program a motion control algorithm by connecting these control elements using a graphic compiler. Key components of the sensorless control algorithms, such as the Angle Estimator, are provided as complete pre-defined control blocks implemented in hardware. A unique analog/digital circuit and algorithm to fully support single shunt current reconstruction is also provided. The 8051 microcontroller performs 2-cycle instruction execution (60MIPS at 120MHz). The MCE and 8051 microcontroller are connected via dual port RAM to process signal monitoring and command input. An advanced graphic compiler for the MCE™ is seamlessly integrated into the MATLAB/Simulink environment, while third party JTAG based emulator tools are supported for 8051 developments. IRMCF311 comes with a small QFP64 pin lead-free package.

## TABLE OF CONTENTS

1	Overview.....	4
2	IRMCF311 Block Diagram and Main Functions .....	5
3	Pinout.....	7
4	Input/Output of IRMCF311 .....	8
4.1	8051 Peripheral Interface Group.....	8
4.2	Motion Peripheral Interface Group.....	9
4.3	Analog Interface Group .....	10
4.4	Power Interface Group.....	11
4.5	Test Interface Group .....	11
5	Application Connections .....	12
6	DC Characteristics.....	13
6.1	Absolute Maximum Ratings .....	13
6.2	System Clock Frequency and Power Consumption.....	13
6.3	Digital I/O DC Characteristics.....	14
6.4	PLL and Oscillator DC Characteristics.....	15
6.5	Analog I/O DC Characteristics .....	15
6.6	Analog I/O DC Characteristics .....	16
6.7	Under Voltage Lockout DC Characteristics .....	17
6.8	CMEXT and AREF Characteristics.....	17
7	AC Characteristics.....	18
7.1	PLL AC Characteristics .....	18
7.2	Analog to Digital Converter AC Characteristics .....	19
7.3	Op amp AC Characteristics.....	20
7.4	Op Amp AC Characteristics .....	20
7.5	SYNC to SVPWM and A/D Conversion AC Timing.....	21
7.6	GATEKILL to SVPWM AC Timing.....	22
7.7	Interrupt AC Timing .....	22
7.8	I <sup>2</sup> C AC Timing.....	23
7.9	SPI AC Timing.....	24
7.9.1	SPI Write AC timing.....	24
7.9.2	SPI Read AC Timing.....	25
7.10	UART AC Timing .....	26
7.11	CAPTURE Input AC Timing .....	27
7.12	JTAG AC Timing .....	28
8	Pin List.....	29
9	Package Dimensions.....	32
10	Part Marking Information.....	33

## TABLE OF FIGURES

Figure 1.	Typical Application Block Diagram Using IRMCF311 .....	4
Figure 2.	IRMCF311 Internal Block Diagram .....	5
Figure 3.	IRMCF311 Pin Configuration .....	7
Figure 4.	Input/Output of IRMCF311 .....	8
Figure 5.	Application Connection of IRMCF311 .....	12
Figure 6.	Clock Frequency vs. Power Consumption.....	13

## TABLE OF TABLES

Table 1.	Absolute Maximum Ratings.....	13
Table 2.	System Clock Frequency.....	13
Table 3.	Digital I/O DC Characteristics .....	14
Table 4.	PLL DC Characteristics .....	15
Table 5.	Analog I/O DC Characteristics .....	15
Table 6.	Analog I/O DC Characteristics .....	16
Table 7.	UVcc DC Characteristics .....	17
Table 8.	CMEXT and AREF DC Characteristics.....	17
Table 9.	PLL AC Characteristics .....	18
Table 10.	A/D Converter AC Characteristics.....	19
Table 11.	Current Sensing OP Amp AC Characteristics.....	20
Table 12.	Voltage sensing OP Amp AC Characteristics.....	20
Table 13.	SYNC AC Characteristics.....	21
Table 14.	GATEKILL to SVPWM AC Timing.....	22
Table 15.	Interrupt AC Timing.....	22
Table 16.	I <sup>2</sup> C AC Timing .....	23
Table 17.	SPI Write AC Timing.....	24
Table 18.	SPI Read AC Timing.....	25
Table 19.	UART AC Timing.....	26
Table 20.	CAPTURE AC Timing .....	27
Table 21.	JTAG AC Timing.....	28
Table 22.	Pin List .....	31

# 1 Overview

IRMCF311 is a new International Rectifier integrated circuit device primarily designed as a one-chip solution for complete inverter controlled air conditioner motor control applications. Unlike a traditional microcontroller or DSP, the IRMCF311 provides a built-in closed loop sensorless control algorithm using the unique Motion Control Engine (MCE™) for permanent magnet motors. The MCE™ consists of a collection of control elements, motion peripherals, a dedicated motion control sequencer and dual port RAM to map internal signal nodes. IRMCF311 also employs a unique single shunt current reconstruction circuit to eliminate additional analog/digital circuitry and enables a direct shunt resistor interface to the IC. Motion control programming is achieved using a dedicated graphical compiler integrated into the MATLAB/Simulink™ development environment. Sequencing, user interface, host communication, and upper layer control tasks can be implemented in the 8051 high-speed 8-bit microcontroller. The 8051 microcontroller is equipped with a JTAG port to facilitate emulation and debugging tools. Figure 1 shows a typical application schematics using IRMCF311.

IRMCF311 is intended for development purpose and contains 48K bytes of RAM, which can be loaded from external EEPROM for 8051 program execution. For high volume production, IRMCK311 contains OTP ROM in place of program RAM to reduce the cost. Both IRMCF311 and IRMCK311 come in the same 64-pin QFP package with identical pin configuration to facilitate PC board layout and transition to mass production

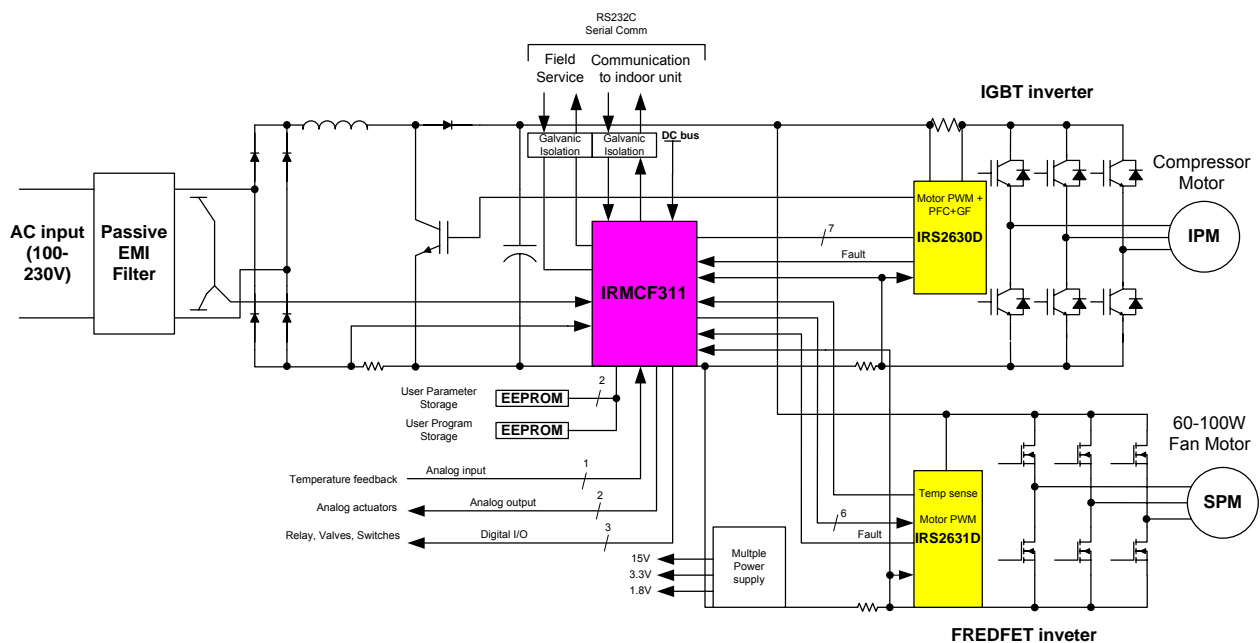
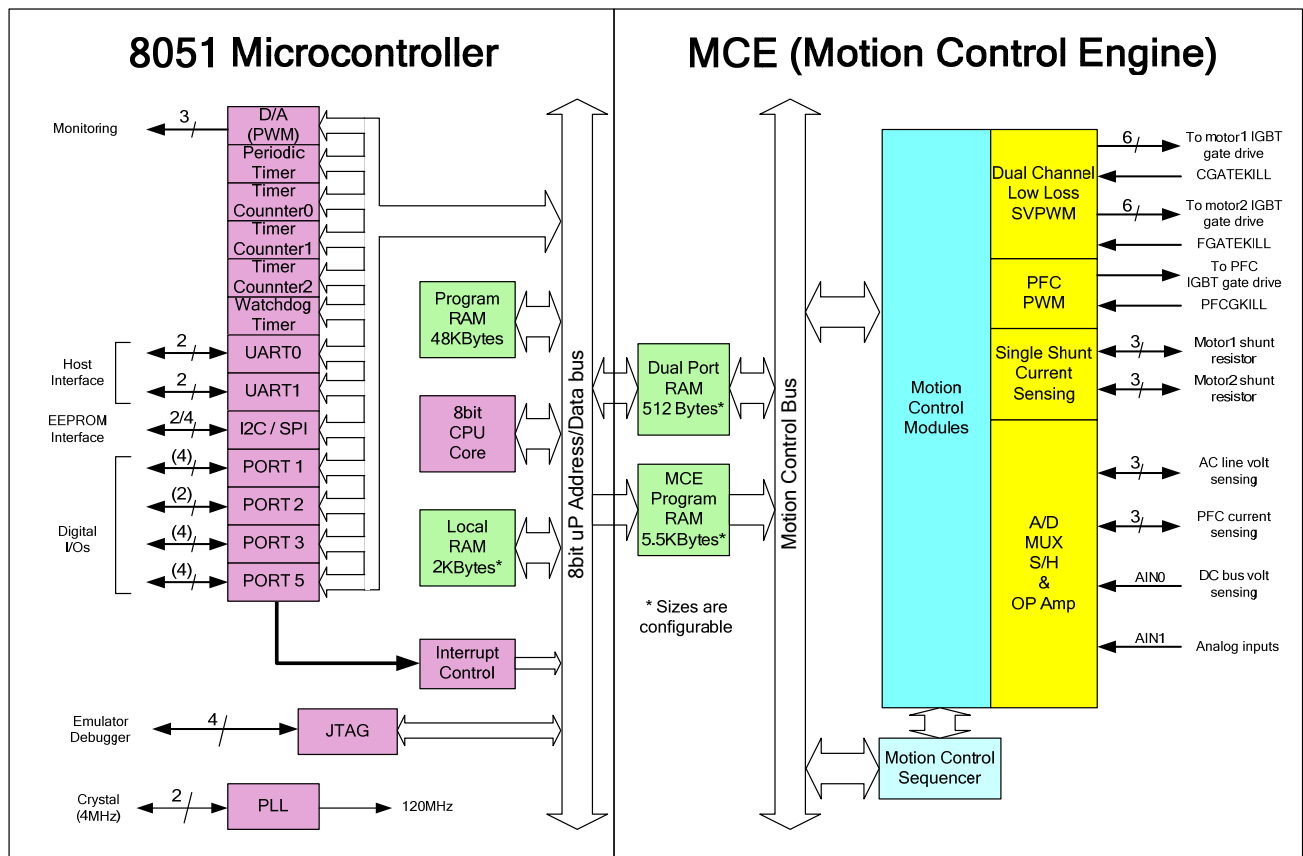

Figure 1. Typical Application Block Diagram Using IRMCF311

## 2 IRMCF311 Block Diagram and Main Functions

IRMCF311 block diagram is shown in Figure 2.



**Figure 2. IRMCF311 Internal Block Diagram**

IRMCF311 contains the following functions for sensorless AC motor control applications:

- Motion Control Engine (MCE™)
  - Proportional plus Integral block
  - Low pass filter
  - Differentiator and lag (high pass filter)
  - Ramp
  - Limit
  - Angle estimate (sensorless control)
  - Inverse Clark transformation
  - Vector rotator
  - Bit latch

- Peak detect
  - Transition
  - Multiply-divide (signed and unsigned)
  - Divide (signed and unsigned)
  - Adder
  - Subtractor
  - Comparator
  - Counter
  - Accumulator
  - Switch
  - Shift
  - ATAN (arc tangent)
  - Function block (any curve fitting, nonlinear function)
  - 16-bit wide Logic operations (AND, OR, XOR, NOT, NEGATE)
  - MCE™ program and data memory (6K byte).<sup>Note 1</sup>
  - MCE™ control sequencer
- 8051 microcontroller
    - Three 16-bit timer
    - 16-bit periodic timer
    - 16-bit analog watchdog timer
    - 16-bit capture timer
    - Up to 14 discrete I/Os
    - Six-channel 12-bit A/D
      - Four buffered channels (0 – 1.2V input)
      - Two unbuffered channels (0 – 1.2V input)
    - JTAG port (4 pins)
    - Up to two channels of analog output (8-bit PWM)
    - Two UART
    - I<sup>2</sup>C/SPI port
    - 48K byte program RAM loaded from external EEPROM
    - 2K byte data RAM.<sup>Note 1</sup>

Note 1: Total size of RAM is 8K byte including MCE program, MCE data, and 8051 data. Different sizes can be allocated depending on applications.

### 3 Pinout

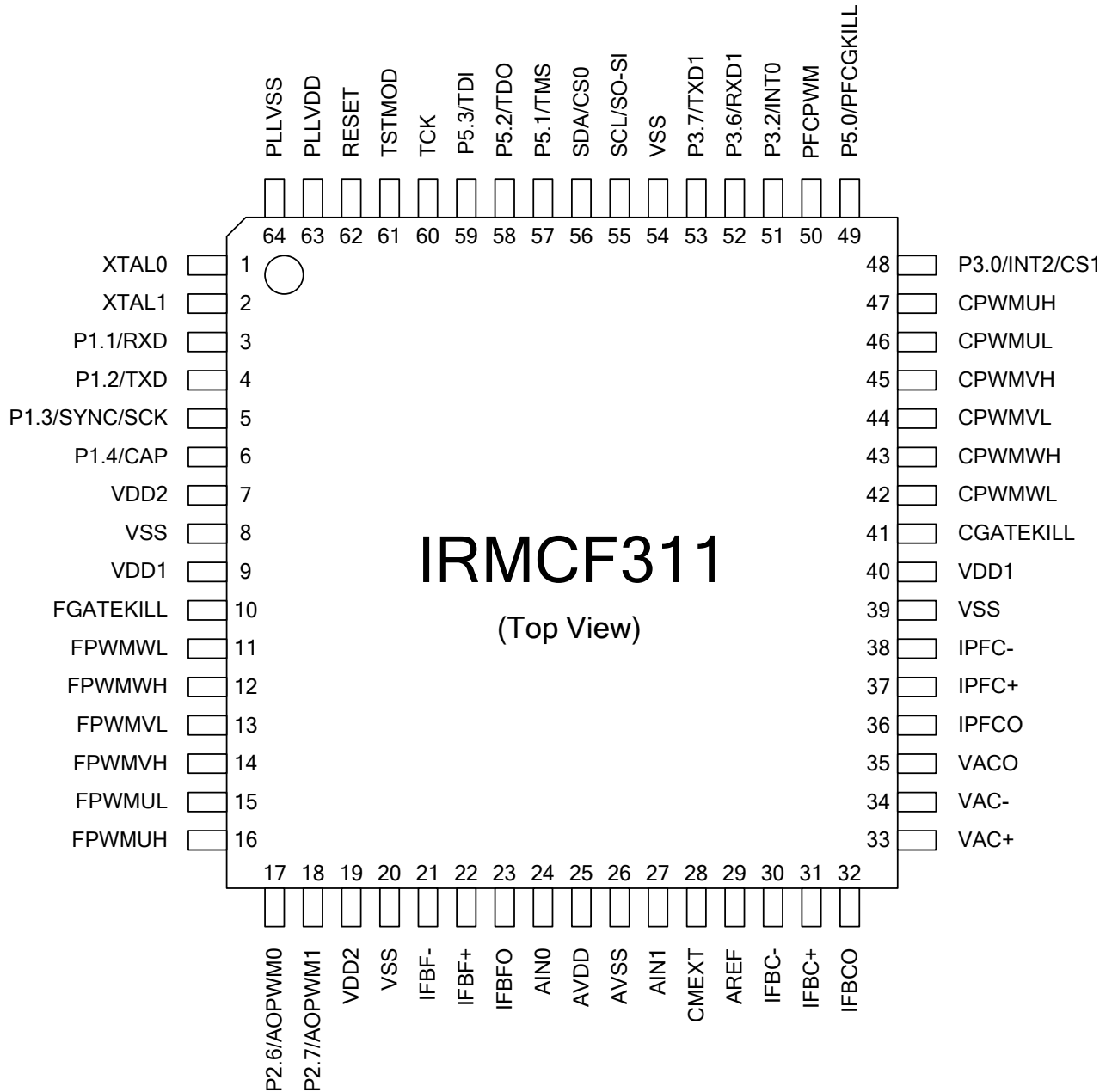

Figure 3. IRMCF311 Pin Configuration

## 4 Input/Output of IRMCF311

All I/O signals of IRMCF311 are shown in Figure 4. All I/O pins are 3.3V logic interface except A/D interface pins.

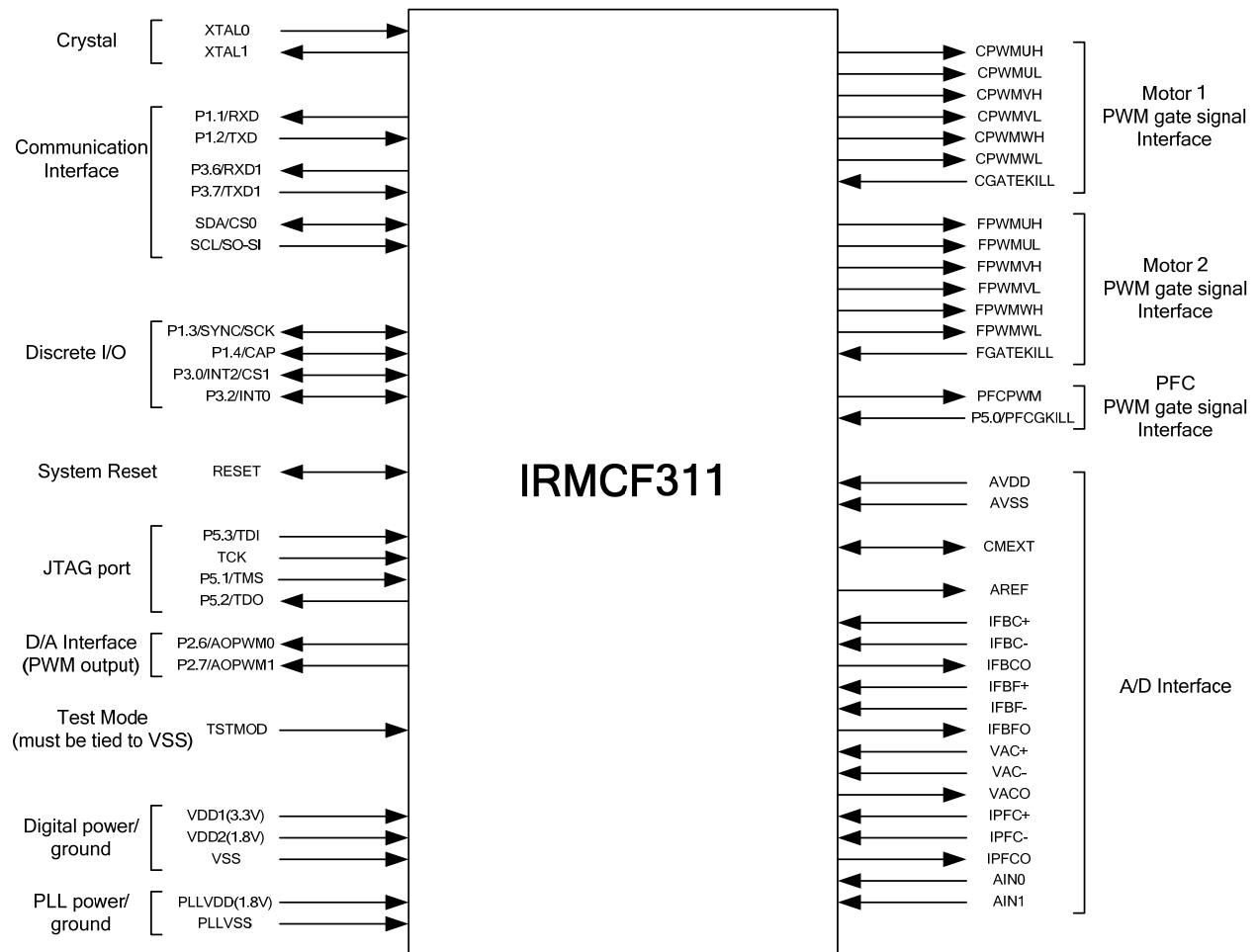

Figure 4. Input/Output of IRMCF311

### 4.1 8051 Peripheral Interface Group

#### UART Interface

P1.1/RXD	Input, Receive data to IRMCF311
P1.2/TXD	Output, Transmit data from IRMCF311
P3.6/RXD1	Input, 2 <sup>nd</sup> channel Receive data to IRMCF311
P3.7/TXD1	Output, 2 <sup>nd</sup> channel Transmit data from IRMCF311



**Discrete I/O Interface**

- P1.3/SYNC/SCK Input/output port 1.3, can be configured as SYNC output or SPI clock, needs to be pulled up to VDD1 in order to boot from I<sup>2</sup>C EEPROM
- P1.4/CAP Input/output port 1.4, can be configured as Capture Timer input
- P3.0/INT2/CS1 Input/output port 3.0, can be configured as external interrupt 2 or SPI chip select 1
- P3.2/INT0 Input/output port 3.2, can be configured as external interrupt 0

**Analog output Interface**

- P2.6/AOPWM0 Output, PWM output 0, 8-bit resolution, configurable carrier frequency
- P2.7/AOPWM1 Output, PWM output 1, 8-bit resolution, configurable carrier frequency

**Crystal Interface**

- XTAL0 Input, connected to crystal
- XTAL1 Output, connected to crystal

**Reset Interface**

- RESET Inout, system reset, needs to be pulled up to VDD1 but doesn't require external RC time constant

**I<sup>2</sup>C/SPI Interface**

- SCL/SO-SI Output, I<sup>2</sup>C clock output or SPI data
- SDA/CS0 Input/output, I<sup>2</sup>C data line or SPI chip select 0
- P3.0/INT2/CS1 Input/output, INT2 or SPI chip select 1
- P1.3/SYNC/SCK Input/output, SYNC output or SPI clock, needs to be pulled up to VDD1 in order boot from I<sup>2</sup>C EEPROM

**4.2 Motion Peripheral Interface Group**

**PWM**

- CPWMUH Output, motor 1 PWM phase U high side gate signal
- CPWMUL Output, motor 1 PWM phase U low side gate signal
- CPWMVH Output, motor 1 PWM phase V high side gate signal
- CPWMVL Output, motor 1 PWM phase V low side gate signal
- CPWMWH Output, motor 1 PWM phase W high side gate signal
- CPWMWL Output, motor 1 PWM phase W low side gate signal
- FPWMUH Output, motor 2 PWM phase U high side gate signal
- FPWMUL Output, motor 2 PWM phase U low side gate signal
- FPWMVH Output, motor 2 PWM phase V high side gate signal

FPWMVL	Output, motor 2 PWM phase V low side gate signal
FPWMWH	Output, motor 2 PWM phase W high side gate signal
FPWMWL	Output, motor 2 PWM phase W low side gate signal
PFCPWM	Output, PFC PWM

**Fault**

CGATEKILL	Input, upon assertion, this negates all six PWM signals for motor 1, programmable logic sense
P5.0/PFCGKILL	Input, upon assertion, this negates PFCPWM signal, programmable logic sense, can be configured as discrete I/O in which case CGATEKILL negates PFCPWM
FGATEKILL	Input, upon assertion, this negates all six PWM signals for motor 2, programmable logic sense

**4.3 Analog Interface Group**

AVDD	Analog power (1.8V)
AVSS	Analog power return
AREF	Buffered 0.6V output
CMEXT	Unbuffered 0.6V, input to the AREF buffer, capacitor needs to be connected.
IFBC+	Input, Operational amplifier positive input for shunt resistor current sensing of motor 1
IFBC-	Input, Operational amplifier negative input for shunt resistor current sensing of motor 1
IFBCO	Output, Operational amplifier output for shunt resistor current sensing of motor 1
IFBF+	Input, Operational amplifier positive input for shunt resistor current sensing of motor 2
IFBF-	Input, Operational amplifier negative input for shunt resistor current sensing of motor 2
IFBFO	Output, Operational amplifier output for shunt resistor current sensing of motor 2
IPFC+	Input, Operational amplifier positive input for PFC current sensing
IPFC-	Input, Operational amplifier negative input for PFC current sensing
IPFO	Output, Operational amplifier output for PFC current sensing
VAC+	Input, Operational amplifier positive input for PFC AC voltage sensing
VAC-	Input, Operational amplifier negative input for PFC AC voltage sensing
VACO	Output, Operational amplifier output for PFC AC voltage sensing
AIN0	Input, Analog input channel 0 (0 - 1.2V), typically configured for DC bus voltage input
AIN1	Input, Analog input channel 1 (0 - 1.2V), needs to be pulled down to AVSS if unused

#### 4.4 Power Interface Group

VDD1	Digital power for I/O (3.3V)
VDD2	Digital power for core logic (1.8V)
VSS	Digital common
PLLVDD	PLL power (1.8V)
PLLVSS	PLL ground return

#### 4.5 Test Interface Group

TSTMOD	Must be tied to VSS, used only for factory testing.
P5.3/TDI	Input, JTAG test data input, or programmable discrete I/O
P5.1/TMS	Input, JTAG test mode select, or programmable discrete I/O
TCK	Input, JTAG test clock
P5.2/TDO	Output, JTAG test data output, or programmable discrete I/O

## 5 Application Connections

Typical application connection is shown Figure 5. All components necessary to implement a complete sensorless drive control algorithm are shown connected to IRMCF311.

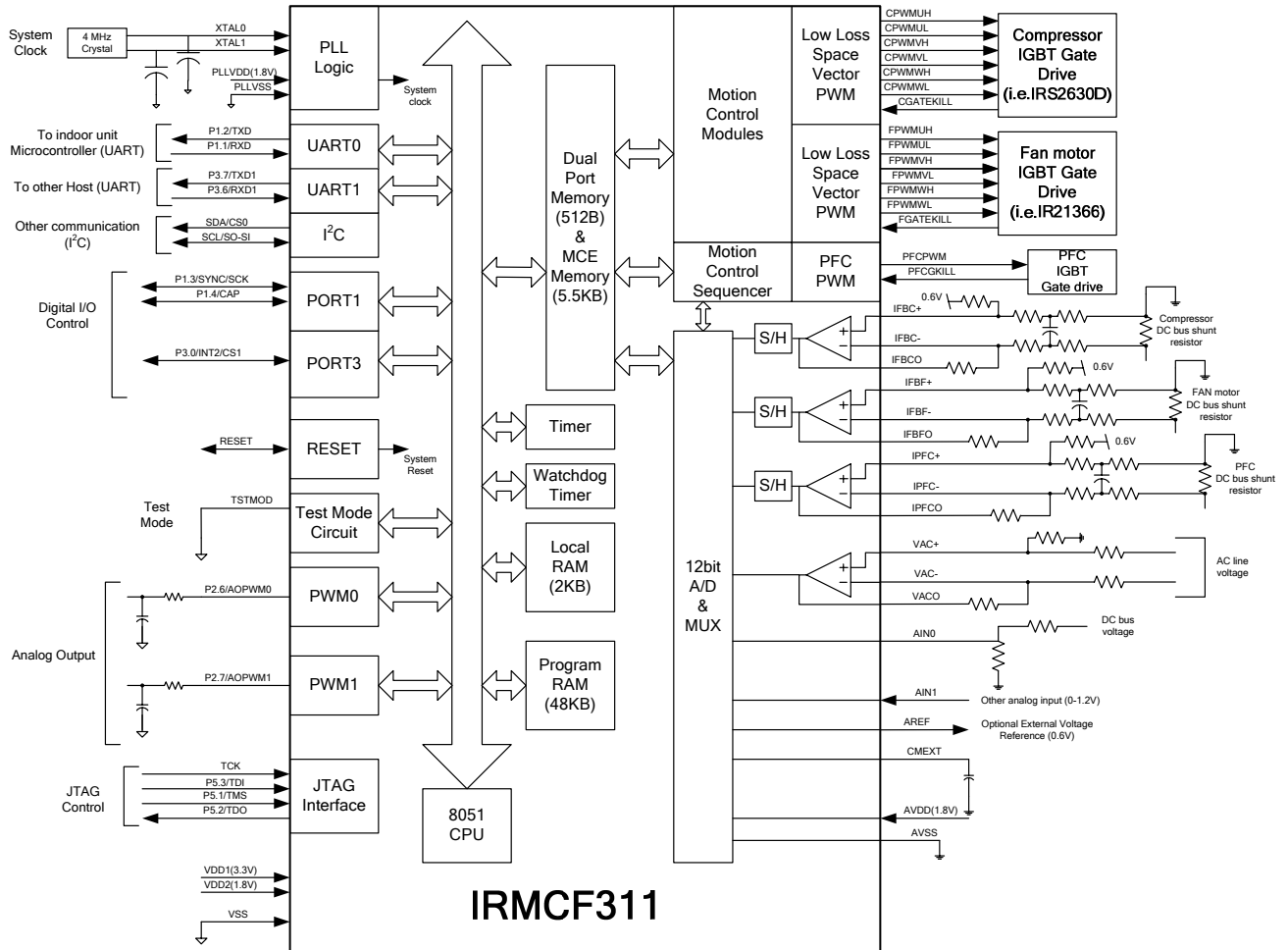

Figure 5. Application Connection of IRMCF311

## 6 DC Characteristics

### 6.1 Absolute Maximum Ratings

Symbol	Parameter	Min	Typ	Max	Condition
V <sub>DD1</sub>	Supply Voltage	-0.3 V	-	3.6 V	Respect to VSS
V <sub>DD2</sub>	Supply Voltage	-0.3 V	-	1.98 V	Respect to VSS
V <sub>IA</sub>	Analog Input Voltage	-0.3 V	-	1.98 V	Respect to AVSS
V <sub>ID</sub>	Digital Input Voltage	-0.3 V	-	3.65 V	Respect to VSS
T <sub>A</sub>	Ambient Temperature	-40 °C	-	85 °C	
T <sub>S</sub>	Storage Temperature	-65 °C	-	150 °C	

**Table 1. Absolute Maximum Ratings**

**Caution:** Stresses beyond those listed in “Absolute Maximum Ratings” may cause permanent damage to the device. These are stress ratings only and function of the device at these or any other conditions beyond those indicated in the operational sections of the specifications are not implied.

### 6.2 System Clock Frequency and Power Consumption

Symbol	Parameter	Min	Typ	Max	Unit
SYSCLK	System Clock	32	-	128	MHz

**Table 2. System Clock Frequency**

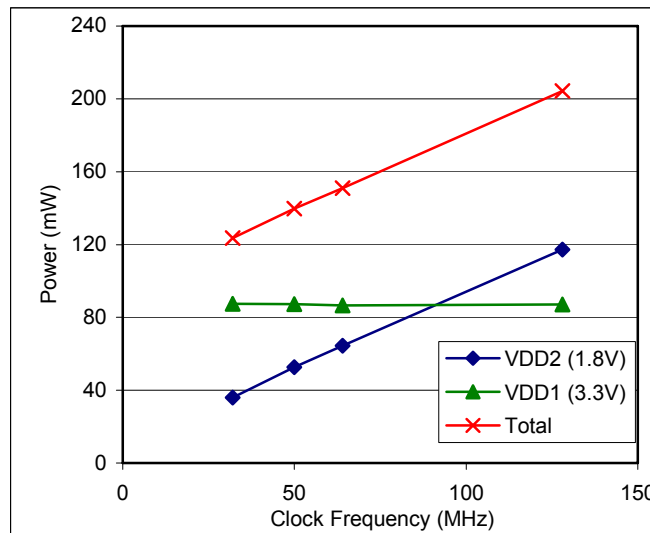

**Figure 6. Clock Frequency vs. Power Consumption**

### 6.3 Digital I/O DC Characteristics

Symbol	Parameter	Min	Typ	Max	Condition
$V_{DD1}$	Supply Voltage	3.0 V	3.3 V	3.6 V	Recommended
$V_{DD2}$	Supply Voltage	1.62 V	1.8 V	1.98 V	Recommended
$V_{IL}$	Input Low Voltage	-0.3 V	-	0.8 V	Recommended
$V_{IH}$	Input High Voltage	2.0 V		3.6 V	Recommended
$C_{IN}$	Input capacitance	-	3.6 pF	-	(1)
$I_L$	Input leakage current		$\pm 10$ nA	$\pm 1$ $\mu$ A	$V_O = 3.3$ V or 0 V
$I_{OL1}^{(2)}$	Low level output current	8.9 mA	13.2 mA	15.2 mA	$V_{OL} = 0.4$ V (1)
$I_{OH1}^{(2)}$	High level output current	12.4 mA	24.8 mA	38 mA	$V_{OH} = 2.4$ V (1)
$I_{OL2}^{(3)}$	Low level output current	17.9 mA	26.3 mA	33.4 mA	$V_{OL} = 0.4$ V (1)
$I_{OH2}^{(3)}$	High level output current	24.6 mA	49.5 mA	81 mA	$V_{OH} = 2.4$ V (1)

**Table 3. Digital I/O DC Characteristics**

Note:

- (1) Data guaranteed by design.
- (2) Applied to SCL/SO-SI, SDA/CS0 pins.
- (3) Applied to P1.1/RXD, P1.2/TXD, P1.3/SYNC/SCK, P1.4/CAP, P2.6/AOPWM0, P2.7/AOPWM1, P3.0/INT2/CS1, P3.2/INT0, P3.6/RXD1, P3.7/TXD1, P5.0/PFCGKILL, P5.1/TMS, P5.2/TDO, P5.3/TDI, CGATEKILL, FGATEKILL, CPWMUL, CPWMUH, CPWMVL, CPWMVH, CPWMWL, CPWMWH, FPWMUL, FPWMUH, FPWMVL, FPWMVH, FPWMWL, FPWMWH, and PFCPWM pins.

### 6.4 PLL and Oscillator DC Characteristics

Symbol	Parameter	Min	Typ	Max	Condition
V <sub>PLLVD</sub>	Supply Voltage	1.62 V	1.8 V	1.92 V	Recommended
V <sub>IL OSC</sub>	Oscillator Input Low Voltage	V <sub>PLLSS</sub>	-	0.2* V <sub>PLLVD</sub>	V <sub>PLLVD</sub> = 1.8 V (1)
V <sub>IH OSC</sub>	Oscillator Input High Voltage	0.8* V <sub>PLLVD</sub>		V <sub>PLLVD</sub>	V <sub>PLLVD</sub> = 1.8 V (1)

**Table 4. PLL DC Characteristics**

Note:

(1) Data guaranteed by design.

### 6.5 Analog I/O DC Characteristics

- OP amps for current sensing (IFBC+, IFBC-, IFBCO, IFBF+, IFBF-, IFBFO, IPFC+, IPFC-, IPFCO)

C<sub>AREF</sub> = 1nF, C<sub>MEXT</sub> = 100nF. Unless specified, Ta = 25°C.

Symbol	Parameter	Min	Typ	Max	Condition
V <sub>AVDD</sub>	Supply Voltage	1.71 V	1.8 V	1.89 V	Recommended
V <sub>OFFSET</sub>	Input Offset Voltage	-	-	26 mV	V <sub>AVDD</sub> = 1.8 V
V <sub>I</sub>	Input Voltage Range	0 V		1.2 V	Recommended
V <sub>OUTSW</sub>	OP amp output operating range	50 mV (1)	-	1.2 V	V <sub>AVDD</sub> = 1.8 V
C <sub>IN</sub>	Input capacitance	-	3.6 pF	-	(1)
R <sub>FDBK</sub>	OP amp feedback resistor	5 kΩ	-	20 kΩ	Requested between op amp output and negative input
OP <sub>GAINCL</sub>	Operating Close loop Gain	80 db	-	-	(1)
CMRR	Common Mode Rejection Ratio	-	80 db	-	(1)
I <sub>SRC</sub>	Op amp output source current	-	1 mA	-	V <sub>OUT</sub> = 0.6 V (1)
I <sub>SNK</sub>	Op amp output sink current	-	100 μA	-	V <sub>OUT</sub> = 0.6 V (1)

**Table 5. Analog I/O DC Characteristics**

Note:

(1) Data guaranteed by design.

## 6.6 Analog I/O DC Characteristics

- OP amp for voltage sensing (VAC+,VAC-,VACO)

$C_{REF} = 1nF$ ,  $C_{MEXT} = 100nF$ . Unless specified,  $T_a = 25^{\circ}C$ .

Symbol	Parameter	Min	Typ	Max	Condition
$V_{AVDD}$	Supply Voltage	1.71 V	1.8 V	1.89 V	
$V_{OFFSET}$	Input Offset Voltage	-	-	26 mV	$V_{AVDD} = 1.8 V$
$V_I$	Input Voltage Range	0 V		1.2 V	
$V_{OUTSW}$	OP amp output operating range	50 mV <sup>(1)</sup>	-	1.2 V	$V_{AVDD} = 1.8 V$
$C_{IN}$	Input capacitance	-	3.6 pF	-	(1)
$OP_{GAINCL}$	Operating Close loop Gain	80 db	-	-	(1)
CMRR	Common Mode Rejection Ratio	-	80 db	-	(1)
$I_{SRC}$	Op amp output source current	-	5 mA	-	$V_{OUT} = 0.6 V$ (1)
$I_{SNK}$	Op amp output sink current	-	500 $\mu A$	-	$V_{OUT} = 0.6 V$ (1)

**Table 6. Analog I/O DC Characteristics**

Note:

(1) Data guaranteed by design.



### 6.7 Under Voltage Lockout DC Characteristics

- Based on AVDD (1.8V)

Unless specified, Ta = 25°C.

Symbol	Parameter	Min	Typ	Max	Condition
UV <sub>CC+</sub>	UVcc positive going Threshold	1.53 V	1.66 V	1.71 V	V <sub>DD1</sub> = 3.3 V
UV <sub>CC-</sub>	UVcc negative going Threshold	1.52 V	1.62 V	1.71 V	V <sub>DD1</sub> = 3.3 V
UV <sub>CCH</sub>	UVcc Hysteresys	-	40 mV	-	

**Table 7. UVcc DC Characteristics**

### 6.8 CMEXT and AREF Characteristics

C<sub>AREF</sub> = 1nF, C<sub>CMEXT</sub> = 100nF. Unless specified, Ta = 25°C.

Symbol	Parameter	Min	Typ	Max	Condition
V <sub>CM</sub>	CMEXT voltage	495 mV	600 mV	700 mV	V <sub>AVDD</sub> = 1.8 V
V <sub>AREF</sub>	Buffer Output Voltage	495 mV	600 mV	700 mV	V <sub>AVDD</sub> = 1.8 V
ΔV <sub>o</sub>	Load regulation (V <sub>DC</sub> -0.6)	-	1 mV	-	(1)
PSRR	Power Supply Rejection Ratio	-	75 db	-	(1)

**Table 8. CMEXT and AREF DC Characteristics**

Note:

(1) Data guaranteed by design.

## 7 AC Characteristics

### 7.1 PLL AC Characteristics

Symbol	Parameter	Min	Typ	Max	Condition
F <sub>CLKIN</sub>	Crystal input frequency	3.2 MHz	4 MHz	60 MHz	(1) (see figure below)
F <sub>PLL</sub>	Internal clock frequency	32 MHz	50 MHz	128 MHz	(1)
F <sub>LWPW</sub>	Sleep mode output frequency	F <sub>CLKIN</sub> ÷ 256	-	-	(1)
J <sub>S</sub>	Short time jitter	-	200 psec	-	(1)
D	Duty cycle	-	50 %	-	(1)
T <sub>LOCK</sub>	PLL lock time	-	-	500 μsec	(1)

**Table 9. PLL AC Characteristics**

Note:

(1) Data guaranteed by design.

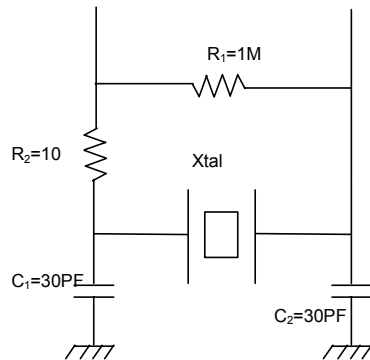

## 7.2 Analog to Digital Converter AC Characteristics

Unless specified,  $T_a = 25^\circ\text{C}$ .

Symbol	Parameter	Min	Typ	Max	Condition
$T_{\text{CONV}}$	Conversion time	-	-	2.05 $\mu\text{sec}$	<sup>(1)</sup>
$T_{\text{HOLD}}$	Sample/Hold maximum hold time	-	-	10 $\mu\text{sec}$	Voltage droop $\leq$ 15 LSB (see figure below)

**Table 10. A/D Converter AC Characteristics**

Note:

(1) Data guaranteed by design.

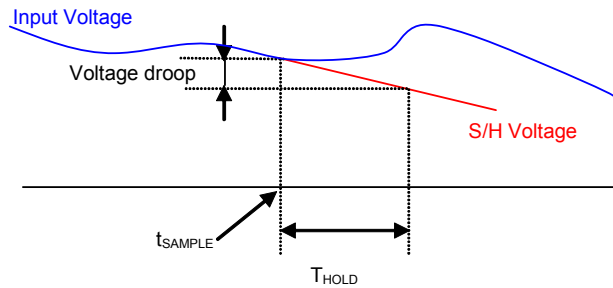

### 7.3 Op amp AC Characteristics

- OP amps for current sensing (IFBC+, IFBC-, IFBCO, IFBF+, IFBF-, IFBFO, IPFC+, IPFC-, IPFCO)

Unless specified, Ta = 25°C.

Symbol	Parameter	Min	Typ	Max	Condition
OP <sub>SR</sub>	OP amp slew rate	-	10 V/μsec	-	V <sub>AVDD</sub> = 1.8 V, CL = 33 pF <sup>(1)</sup>
OP <sub>IMP</sub>	OP input impedance	-	10 <sup>8</sup> Ω	-	<sup>(1)</sup>
T <sub>SET</sub>	Settling time	-	400 ns	-	V <sub>AVDD</sub> = 1.8 V, CL = 33 pF <sup>(1)</sup>

**Table 11. Current Sensing OP Amp AC Characteristics**

Note:

(1) Data guaranteed by design.

### 7.4 Op Amp AC Characteristics

- OP amp for voltage sensing (VAC+, VAC-, VACO)

Unless specified, Ta = 25°C.

Symbol	Parameter	Min	Typ	Max	Condition
OP <sub>SR</sub>	OP amp slew rate		2.5 V/μsec	-	V <sub>AVDD</sub> = 1.8 V, CL = 33 pF <sup>(1)</sup>
OP <sub>IMP</sub>	OP input impedance	-	10 <sup>8</sup> Ω	-	<sup>(1)</sup>
T <sub>SET</sub>	Settling time		650 ns		V <sub>AVDD</sub> = 1.8 V, CL = 33 pF <sup>(1)</sup>

**Table 12. Voltage sensing OP Amp AC Characteristics**

Note:

(1) Data guaranteed by design.

### 7.5 SYNC to SVPWM and A/D Conversion AC Timing

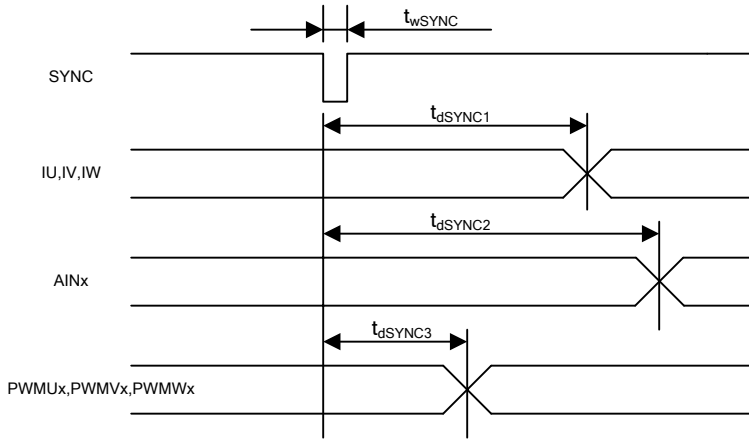

Unless specified,  $T_a = 25^\circ\text{C}$ .

Symbol	Parameter	Min	Typ	Max	Unit
$t_{wSYNC}$	SYNC pulse width	-	32	-	SYSClk
$t_{dSYNC1}$	SYNC to current feedback conversion time	-	-	100	SYSClk
$t_{dSYNC2}$	SYNC to AIN0-6 analog input conversion time	-	-	200	SYSClk (1)
$t_{dSYNC3}$	SYNC to PWM output delay time	-	-	2	SYSClk

**Table 13. SYNC AC Characteristics**

Note:

(1) AIN1 through AIN6 channels are converted once every 6 SYNC events

### 7.6 GATEKILL to SVPWM AC Timing

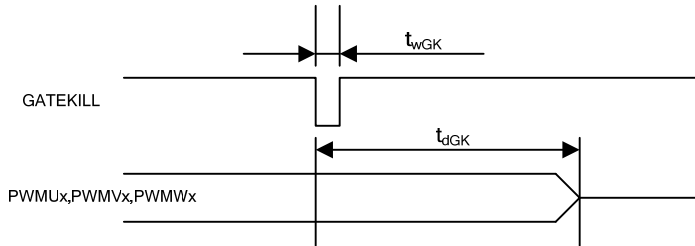

Unless specified, Ta = 25°C.

Symbol	Parameter	Min	Typ	Max	Unit
t <sub>wGK</sub>	GATEKILL pulse width	32	-	-	SYSCCLK
t <sub>dGK</sub>	GATEKILL to PWM output delay	-	-	100	SYSCCLK

**Table 14. GATEKILL to SVPWM AC Timing**

### 7.7 Interrupt AC Timing

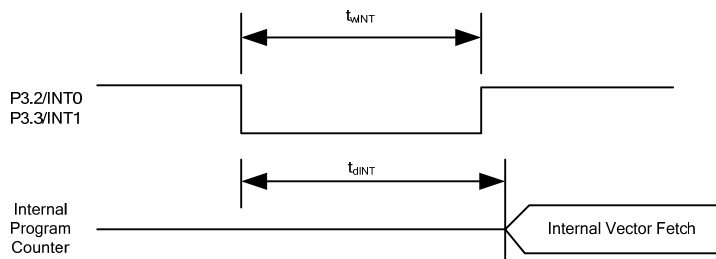

Unless specified, Ta = 25°C.

Symbol	Parameter	Min	Typ	Max	Unit
t <sub>wINT</sub>	INT0, INT1 Interrupt Assertion Time	4	-	-	SYSCCLK
t <sub>dINT</sub>	INT0, INT1 latency	-	-	4	SYSCCLK

**Table 15. Interrupt AC Timing**

### 7.8 I<sup>2</sup>C AC Timing

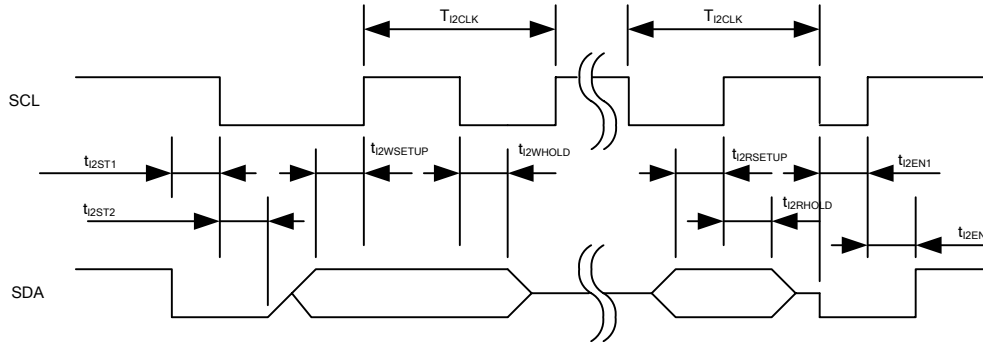

Unless specified, Ta = 25°C.

Symbol	Parameter	Min	Typ	Max	Unit
T <sub>I2CLK</sub>	I <sup>2</sup> C clock period	10	-	8192	SYCLK
t <sub>I2ST1</sub>	I <sup>2</sup> C SDA start time	0.25	-	-	T <sub>I2CLK</sub>
t <sub>I2ST2</sub>	I <sup>2</sup> C SCL start time	0.25	-	-	T <sub>I2CLK</sub>
t <sub>I2WSETUP</sub>	I <sup>2</sup> C write setup time	0.25	-	-	T <sub>I2CLK</sub>
t <sub>I2WHOLD</sub>	I <sup>2</sup> C write hold time	0.25	-	-	T <sub>I2CLK</sub>
t <sub>I2RSETUP</sub>	I <sup>2</sup> C read setup time	I <sup>2</sup> C filter time <sup>(1)</sup>	-	-	SYCLK
t <sub>I2RHOLD</sub>	I <sup>2</sup> C read hold time	1	-	-	SYCLK

**Table 16. I<sup>2</sup>C AC Timing**

Note:

- (1) I<sup>2</sup>C read setup time is determined by the programmable filter time applied to I<sup>2</sup>C communication.

## 7.9 SPI AC Timing

### 7.9.1 SPI Write AC timing

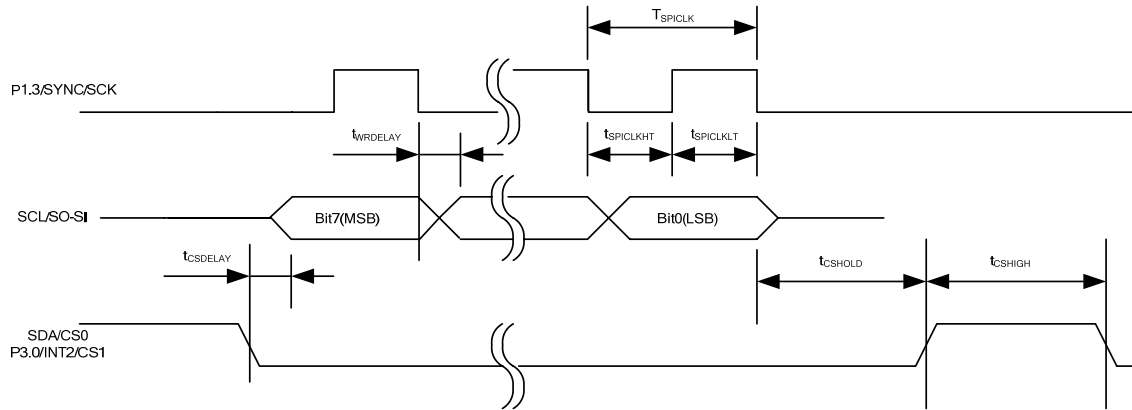

Unless specified,  $T_a = 25^\circ\text{C}$ .

Symbol	Parameter	Min	Typ	Max	Unit
$T_{SPICLK}$	SPI clock period	4	-	-	SYSCCLK
$t_{SPICLKHT}$	SPI clock high time	-	1/2	-	$T_{SPICLK}$
$t_{SPICLKLT}$	SPI clock low time	-	1/2	-	$T_{SPICLK}$
$t_{CSDELAY}$	CS to data delay time	-	-	10	nsec
$t_{WRDELAY}$	CLK falling edge to data delay time	-	-	10	nsec
$t_{CSHIGH}$	CS high time between two consecutive byte transfer	1	-	-	$T_{SPICLK}$
$t_{CSHOLD}$	CS hold time	-	1	-	$T_{SPICLK}$

**Table 17. SPI Write AC Timing**



7.9.2 SPI Read AC Timing

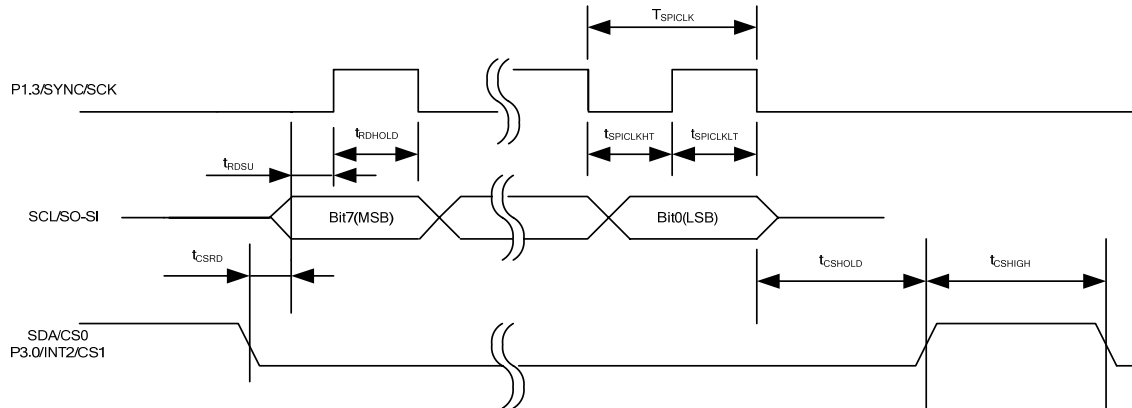

Unless specified, Ta = 25°C.

Symbol	Parameter	Min	Typ	Max	Unit
T <sub>SPICLK</sub>	SPI clock period	4	-	-	SYSCLK
t <sub>SPICLKHT</sub>	SPI clock high time	-	1/2	-	T <sub>SPICLK</sub>
t <sub>SPICLKLT</sub>	SPI clock low time	-	1/2	-	T <sub>SPICLK</sub>
t <sub>CSRD</sub>	CS to data delay time	-	-	10	nsec
t <sub>RDSU</sub>	SPI read data setup time	10	-	-	nsec
t <sub>RDHOLD</sub>	SPI read data hold time	10	-	-	nsec
t <sub>CSHIGH</sub>	CS high time between two consecutive byte transfer	1	-	-	T <sub>SPICLK</sub>
t <sub>CSHOLD</sub>	CS hold time	-	1	-	T <sub>SPICLK</sub>

Table 18. SPI Read AC Timing

### 7.10 UART AC Timing

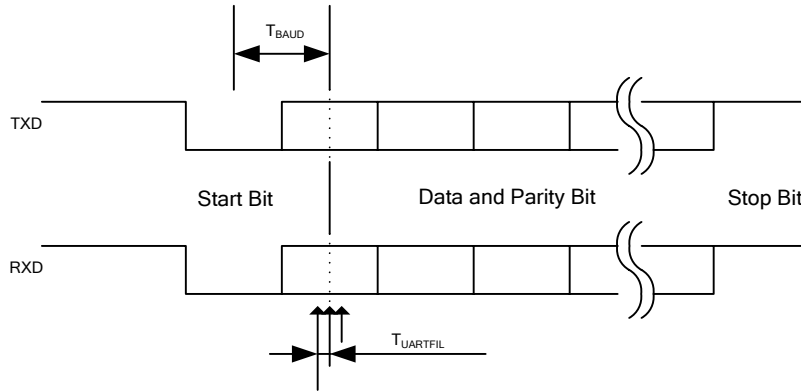

Unless specified,  $T_a = 25^\circ\text{C}$ .

Symbol	Parameter	Min	Typ	Max	Unit
$T_{BAUD}$	Baud Rate Period	-	57600	-	bit/sec
$T_{UARTFIL}$	UART sampling filter period <sup>(1)</sup>	-	1/16	-	$T_{BAUD}$

**Table 19. UART AC Timing**

Note:

- (1) Each bit including start and stop bit is sampled three times at center of a bit at an interval of  $1/16 T_{BAUD}$ . If three sampled values do not agree, then UART noise error is generated.

### 7.11 CAPTURE Input AC Timing

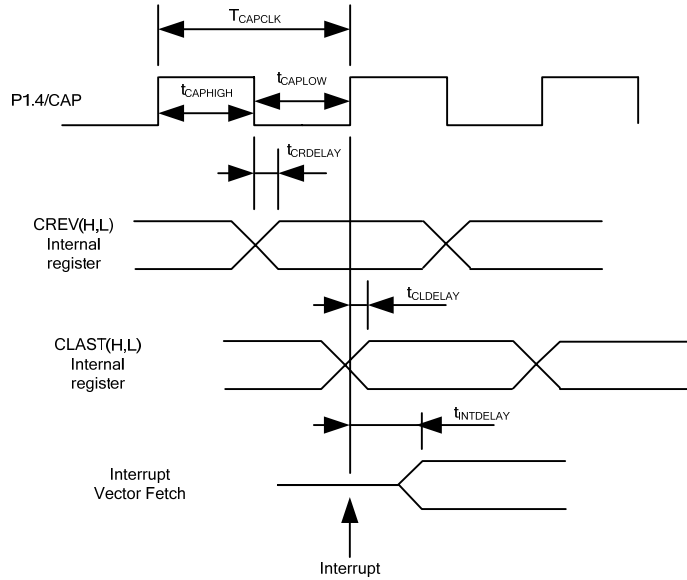

Unless specified,  $T_a = 25^\circ\text{C}$ .

Symbol	Parameter	Min	Typ	Max	Unit
$T_{CAPCLK}$	CAPTURE input period	8	-	-	SYSCCLK
$t_{CAPHIGH}$	CAPTURE input high time	4	-	-	SYSCCLK
$t_{CAPLOW}$	CAPTURE input low time	4	-	-	SYSCCLK
$t_{CRDELAY}$	CAPTURE falling edge to capture register latch time	-	-	4	SYSCCLK
$t_{CLDELAY}$	CAPTURE rising edge to capture register latch time	-	-	4	SYSCCLK
$t_{INTDELAY}$	CAPTURE input interrupt latency time	-	-	4	SYSCCLK

Table 20. CAPTURE AC Timing

### 7.12 JTAG AC Timing

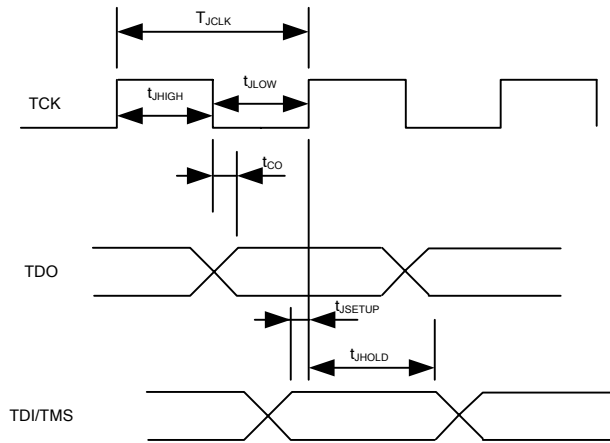

Unless specified,  $T_a = 25^\circ\text{C}$ .

Symbol	Parameter	Min	Typ	Max	Unit
$T_{JCLK}$	TCK Period	-	-	50	MHz
$t_{JHIGH}$	TCK High Period	10	-	-	nsec
$t_{JLOW}$	TCK Low Period	10	-	-	nsec
$t_{CO}$	TCK to TDO propagation delay time	0	-	5	nsec
$t_{JSETUP}$	TDI/TMS setup time	4	-	-	nsec
$t_{JHOLD}$	TDI/TMS hold time	0	-	-	nsec

**Table 21. JTAG AC Timing**

## 8 Pin List

Pin Number	Pin Name	Internal IC Pull-up /Pull-down	Pin Type	Description
1	XTAL0		I	Crystal input
2	XTAL1		O	Crystal output
3	P1.1/RXD		I/O	Discrete programmable I/O or UART receive input
4	P1.2/TXD		I/O	Discrete programmable I/O or UART transmit output
5	P1.3/SYNC/ SCK		I/O	Discrete programmable I/O or SYNC output or SPI clock, needs to be pulled up to VDD1 in order to boot from I <sup>2</sup> C EEPROM
6	P1.4/CAP		I/O	Discrete programmable I/O or Capture Timer input
7	VDD2		P	1.8V digital power
8	VSS		P	Digital common
9	VDD1		P	3.3V digital power
10	FGATEKILL		I	Fan PWM shutdown input, 2- $\mu$ sec digital filter, configurable either high or low true.
11	FPWMWL	70 k $\Omega$ Pull up	O	Fan PWM gate drive for phase W low side, configurable either high or low true
12	FPWMWH	70 k $\Omega$ Pull up	O	Fan PWM gate drive for phase W high side, configurable either high or low true
13	FPWMVL	70 k $\Omega$ Pull up	O	Fan PWM gate drive for phase V low side, configurable either high or low true
14	FPWMVH	70 k $\Omega$ Pull up	O	Fan PWM gate drive for phase V high side, configurable either high or low true
15	FPWMUL	70 k $\Omega$ Pull up	O	Fan PWM gate drive for phase U low side, configurable either high or low true
16	FPWMUH	70 k $\Omega$ Pull up	O	Fan PWM gate drive for phase U high side, configurable either high or low true
17	P2.6/ AOPWM0		I/O	Discrete programmable I/O or analog output 0 (PWM)
18	P2.7/ AOPWM1			Discrete programmable I/O or analog output 1 (PWM)
19	VDD2		P	1.8V digital power
20	VSS		P	Digital common
21	IFBF-		I	Fan single shunt current sensing OP amp input (-)
22	IFBF+		I	Fan single shunt current sensing OP amp input (+)
23	IFBFO		O	Fan single shunt current sensing OP amp output
24	AIN0		I	Analog input channel 0, 0-1.2V range, needs to be pulled down to AVSS if unused
25	AVDD		P	1.8V analog power

Pin Number	Pin Name	Internal IC Pull-up /Pull-down	Pin Type	Description
26	AVSS		P	Analog common
27	AIN1		I	Analog input channel 1, 0-1.2V range, needs to be pulled down to AVSS if unused
28	AREF		O	Analog reference voltage output (0.6V)
29	CMEXT		O	Unbuffered analog reference voltage output (0.6V)
30	IFBC-		I	Compressor single shunt current sensing OP amp input (-)
31	IFBC+		I	Compressor single shunt current sensing OP amp input (+)
32	IFBCO		O	Compressor single shunt current sensing OP amp output
33	VAC-		I	AC input voltage sensing OP amp input (-)
34	VAC+		I	AC input voltage sensing OP amp input (+)
35	VACO		O	AC input voltage sensing OP amp output
36	IPFCO		O	PFC shunt current sensing OP amp output
37	IPFC+		I	PFC shunt current sensing OP amp input (+)
38	IPFC-		I	PFC shunt current sensing OP amp input (-)
39	VSS		P	Digital common
40	VDD1		P	3.3V digital power
41	CGATEKILL		I	Compressor PWM shutdown input, 2- $\mu$ sec digital filter, configurable either high or low true.
42	CPWMWL	70 k $\Omega$ Pull up	O	Compressor PWM gate drive for phase W low side, configurable either high or low true
43	CPWMWH	70 k $\Omega$ Pull up	O	Compressor PWM gate drive for phase W high side, configurable either high or low true
44	CPWMVL	70 k $\Omega$ Pull up	O	Compressor PWM gate drive for phase V low side, configurable either high or low true
45	CPWMVH	70 k $\Omega$ Pull up	O	Compressor PWM gate drive for phase V high side, configurable either high or low true
46	CPWMUL	70 k $\Omega$ Pull up	O	Compressor PWM gate drive for phase U low side, configurable either high or low true
47	CPWMUH	70 k $\Omega$ Pull up	O	Compressor PWM gate drive for phase U high side, configurable either high or low true
48	P3.0/INT2		I/O	Discrete programmable I/O or INT2 digital input
49	P5.0/PFCGKILL		I	Discrete programmable I/O or PFC PWM shutdown input, 2- $\mu$ sec digital filter, configurable either high or low true.
50	PFCPWM	70 k $\Omega$ Pull up	O	PFC PWM gate drive, configurable either high or low true
51	P3.2/INT0		I/O	Discrete programmable I/O or INT0 input

Pin Number	Pin Name	Internal IC Pull-up /Pull-down	Pin Type	Description
52	P3.6/RXD1		I/O	Discrete programmable I/O or 2 <sup>nd</sup> UART receive input
53	P3.7/TXD1		I/O	Discrete programmable I/O or 2 <sup>nd</sup> UART transmit output
54	VSS		P	Digital common
55	SCL/SO-SI		I/O	I <sup>2</sup> C clock output or SPI data
56	SDA/CS0		I/O	I <sup>2</sup> C data or SPI chip select 0
57	P5.1/TMS		I/O	Discrete programmable I/O or JTAG test mode select
58	P5.2/TDO		I/O	Discrete programmable I/O or JTAG port test data output
59	P5.3/TDI		I/O	Discrete programmable I/O or JTAG test data input
60	TCK		I	JTAG test clock
61	TSTMOD	58 kΩ pull down	I	Test mode. Must be tied to VSS. Factory use only
62	RESET		I/O	Reset , low true, Schmitt trigger input
63	PLLVDD		P	1.8 V PLL power
64	PLLVSS		P	PLL ground

**Table 22. Pin List**

# 9 Package Dimensions

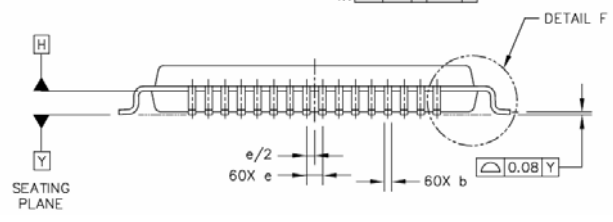
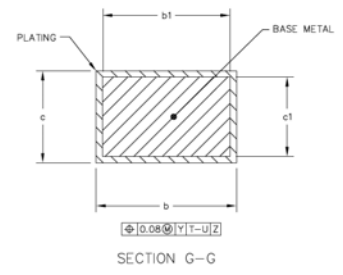
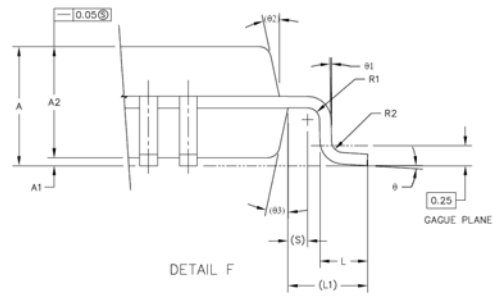
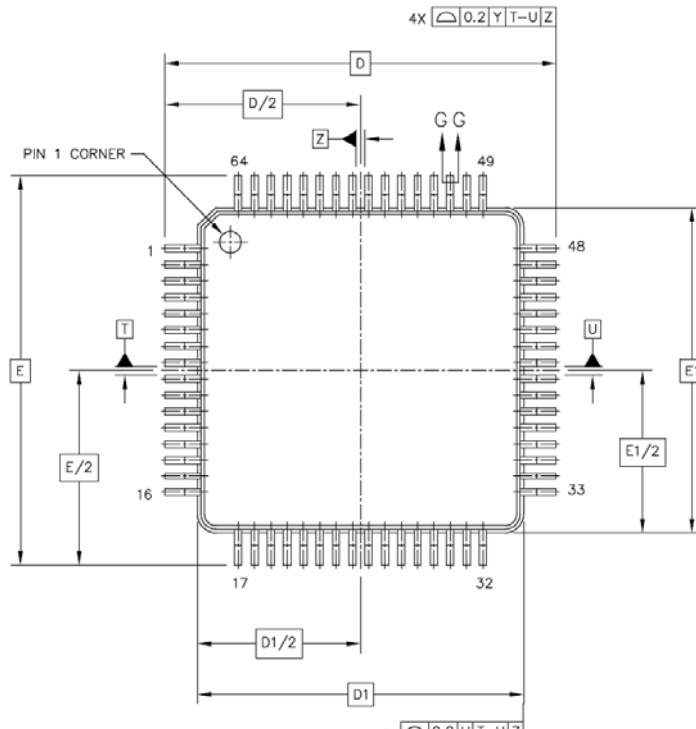

- NOTES:
1. DIMENSIONS ARE IN MILLIMETERS.
  2. INTERPRET DIMENSIONS AND TOLERANCES PER ASME Y14.5M-1994.
  3. DATUM PLANE DATUM H IS LOCATED AT BOTTOM OF LEAD AND IS COINCIDENT WITH THE LEAD WHERE THE LEAD EXITS THE PLASTIC BODY AT THE BOTTOM OF THE PARTING LINE.
  4. DATUM T, U, AND Z TO BE DETERMINED AT DATUM PLANE H.
  5. DIMENSIONS D AND E TO BE DETERMINED AT SEATING PLANE DATUM Y.
  6. DIMENSIONS D1 AND E1 DO NOT INCLUDE MOLD PROTRUSION. ALLOWABLE PROTRUSION IS 0.25 PER SIDE. DIMENSIONS D1 AND E1 DO INCLUDE MOLD MISMATCH AND ARE DETERMINED AT DATUM PLANE DATUM H.
  7. DIMENSION b DOES NOT INCLUDE DAMBAR PROTRUSION. DAMBAR PROTRUSION SHALL NOT CAUSE THE b DIMENSION TO EXCEED 0.35. MINIMUM SPACE BETWEEN PROTRUSION AND ADJACENT LEAD OR PROTRUSION 0.07.

DIM	MIN	MAX	DIM	MIN	MAX	DIM	MIN	MAX
A	---	1.6	L1		1 REF			
A1	0.05	0.15	R1	0.1	0.2			
A2	1.35	1.45	R2	0.1	0.2			
b	0.17	0.27	S		0.2 REF			
b1	0.17	0.23	θ	0°	7°			
c	0.09	0.2	θ1	0°	---			
c1	0.09	0.16	θ2		12° REF			
D		12 BSC	θ3		12° REF			
D1		10 BSC						
e		0.5 BSC						
E		12 BSC						
E1		10 BSC						
L	0.45	0.75						



## 10 Part Marking Information

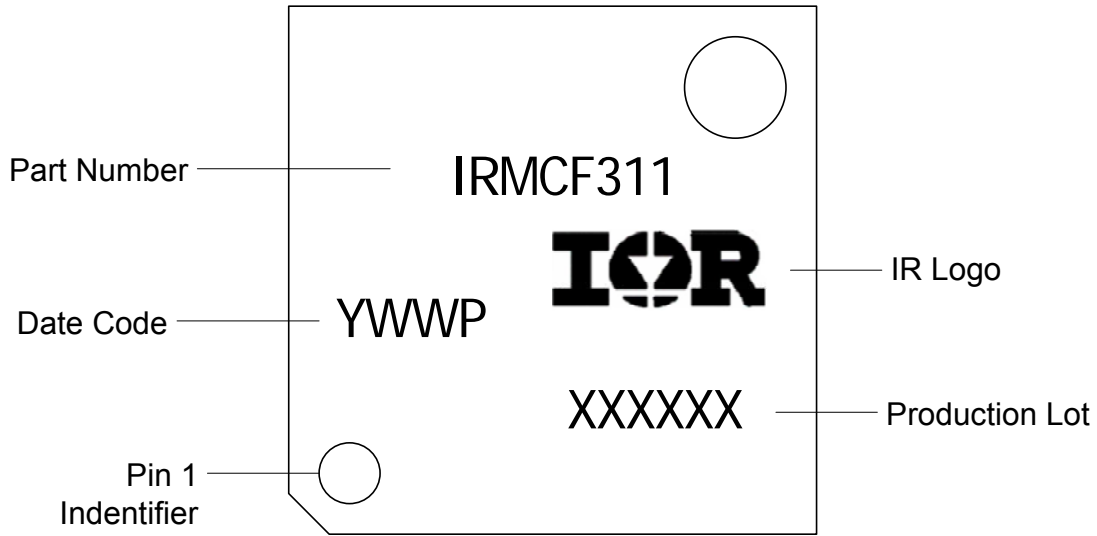

### Order Information

**Lead-Free Part in 64-lead QFP**  
**Moisture sensitivity rating – MSL3**

Part number	Order quantities
IRMCF311TR	1500 parts on tape and reel in dry pack
IRMCF311TY	1600 parts on trays (160 parts per tray) in dry pack