

Dual Channel Sensorless PM Motor Control IC MCE™(Motion Control Engine) based sinusoidal sensorless control

Features

- MCE™ based hardware computation for complex motor control algorithm
- Enable two sensorless PM motor control and digital PFC control
- Increase energy efficiency to exceed energy guideline
- Supports both interior and surface permanent magnet motors
- Built-in hardware peripheral of single shunt current feedback reconstruction for compressor and fan motor. No external OP amp required
- 2 channel loss minimization Space Vector PWM
- 3 channel analog output (PWM)
- Embedded 8-bit high speed microcontroller (8051) for flexible I/O and man-machine control
- JTAG programming port for emulation/debugger
- 2 channel serial communication interface (UART)
- I²C serial interface
- Analog watchdog timer, 4 Timer/counter
- External EEPROM and internal RAM facilitates debugging and code development
- Pin compatible with mask ROM version
- 3.3V/1.8V CMOS

Product Summary

Maximum clock input (crystal)	60 MHz
Internal max clock frequency (SYSCLK)	120 MHz
Sensorless control computation time	11 μsec typ
MCE™ computation data range	16 bit signed
Program RAM	48K byte
RAM	8K byte
GateKill latency (digital filtered)	2 μsec
PWM carrier frequency data range	16 bit
A/D input channels	11
A/D converter resolution	12 bit
A/D converter conversion speed	2 μsec
8051 instruction execution speed	2 SYSCLK
Analog output (PWM) resolution	8 bit
UART baud rate (typ)	57.6 kbps
Package	QFP100

Description

IRMCF312 is a high performance RAM based motion control IC designed primarily for appliance applications. IRMCF312 is designed to achieve low cost and high performance control solutions for advanced inverterized appliance motor control. IRMCF312 contains two computation engines. One is Motion Control Engine (MCE™) for sensorless control of permanent magnet motors; the other is an 8-bit high speed microcontroller (8051). Both computation engines are integrated into one monolithic chip. The MCE™ contains a collection of control elements such as Proportional plus Integral, Vector rotator, Angle estimator, Multiply/Divide, Low loss SVPWM, SingleShuntIFB, etc., which are implemented in hardware. The user can program a motion control algorithm by connecting these control elements using a graphic compiler. Key components of the sensorless control algorithms, such as the Angle Estimator, are provided as complete pre-defined control blocks. A unique analog/digital circuit and algorithm to fully support single shunt current reconstruction is also provided. The 8051 microcontroller performs 2-cycle instruction execution (60MIPS at 120MHz). The MCE and 8051 microcontroller are connected via dual port RAM to process signal monitoring and command input. An advanced graphic compiler for the MCE™ is seamlessly integrated into the MATLAB/Simulink environment, while third party JTAG based emulator tools are supported for 8051 development. IRMCF312 comes with a small QFP100 pin package.



1 Overview

IRMCF312 is a new International Rectifier integrated circuit device primarily designed as a one-chip solution for complete inverter controlled appliance dual motor control applications. Unlike a traditional microcontroller or DSP, the IRMCF312 provides a built-in closed loop sensorless control algorithm using the unique Motion Control Engine (MCE™) for permanent magnet motors. The MCE™ consists of a collection of control elements, motion peripherals, a dedicated motion control sequencer and dual port RAM to map internal signal nodes. IRMCF312 also employs a unique single shunt current reconstruction circuit to eliminate additional analog/digital circuitry and enables a direct shunt resistor interface to the IC. The sensorless control is the same for both motors with a single shunt current sensing capability. Motion control programming is achieved using a dedicated graphical compiler integrated into the MATLAB/Simulink™ development environment. Sequencing, user interface, host communication, and upper layer control tasks can be implemented in the 8051 high speed 8-bit microcontroller. The 8051 microcontroller is equipped with a JTAG port to facilitate emulation and debugging tools. Figure 1 shows a typical application schematic using IRMCF312.

IRMCF312 contains 48K bytes of RAM, which can be loaded from external EEPROM and is intended to be used for development purposes. For high volume production, the program RAM is replaced with 48K bytes of Mask ROM. Both development and mask-ROM versions come in a 100-pin QFP package with identical pin configuration to facilitate PC board layout and transition to mass production.

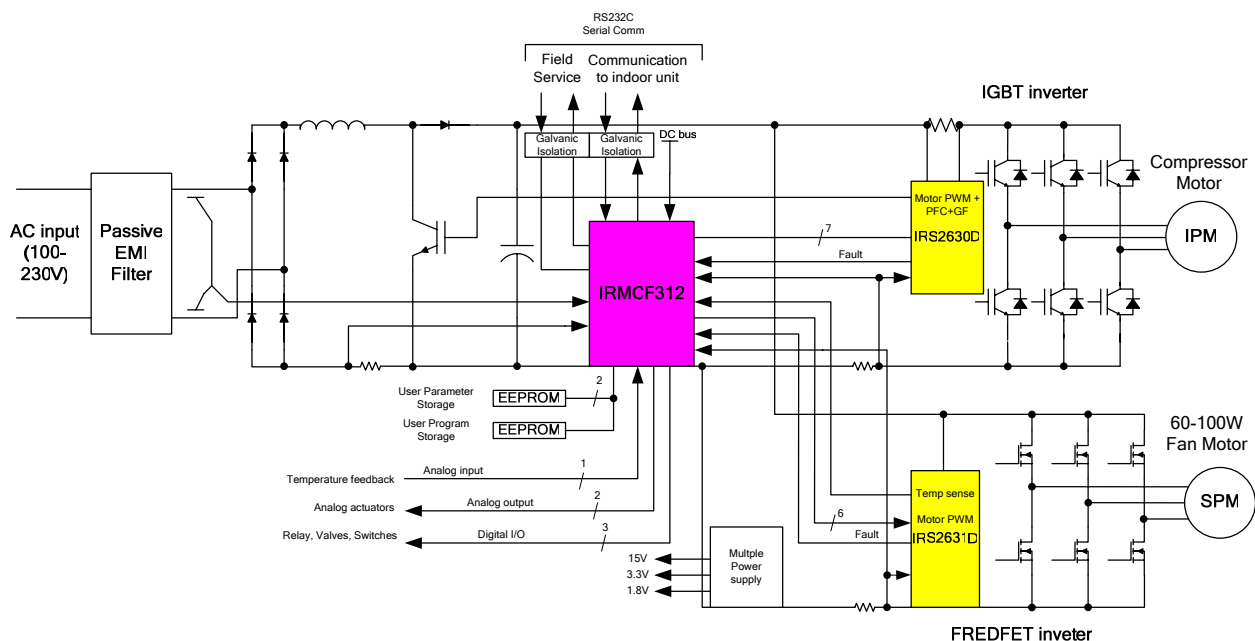

Figure 1. Typical Application Block Diagram Using IRMCF312

2 IRMCF312 Block Diagram and Main Functions

IRMCF312 block diagram is shown in Figure 2.

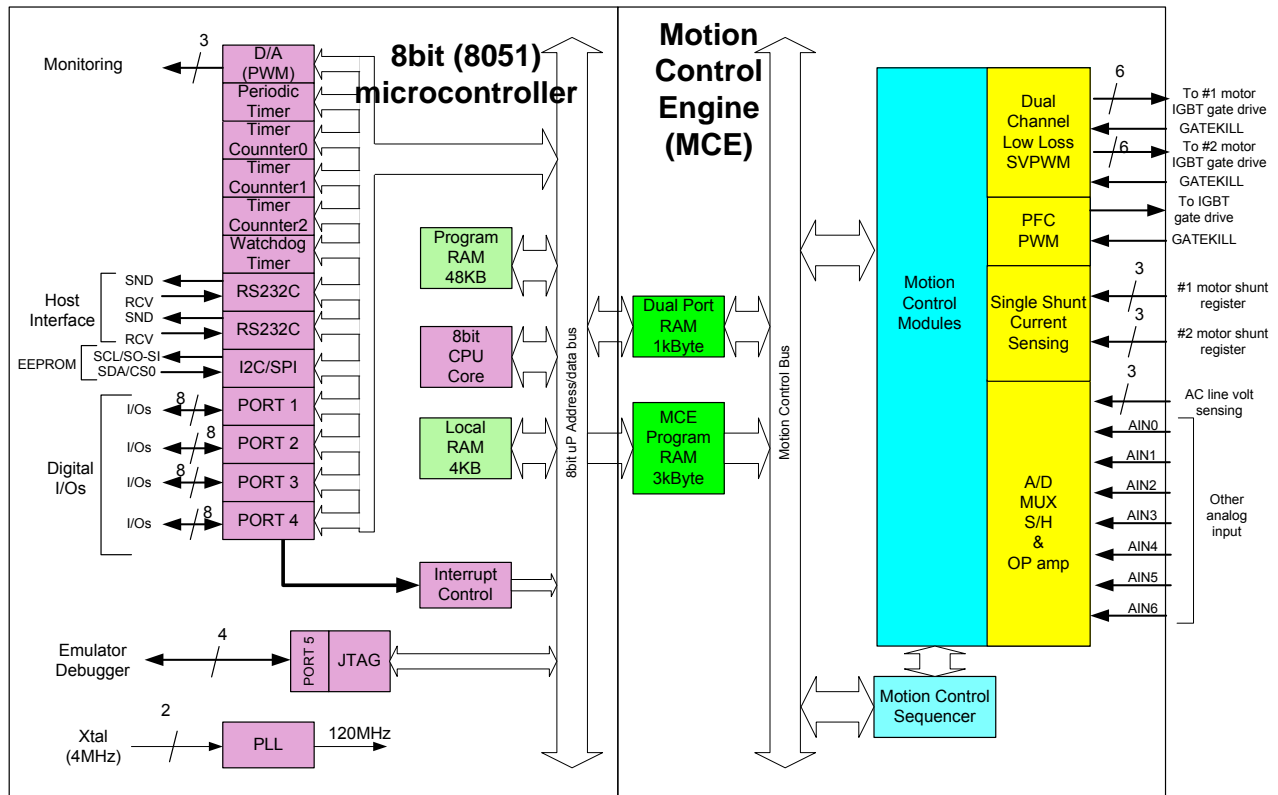

Figure 2. IRMCF312 Internal Block Diagram

IRMCF312 contains the following functions for sensorless AC motor control applications:

- Motion Control Engine (MCE™)
 - Proportional plus Integral block
 - Low pass filter
 - Differentiator and lag
 - Ramp
 - Limit
 - FOC Control block
 - Clark transformation
 - Inverse Clark transformation

- Vector rotator
- Multiply-divide (signed and unsigned)
- Adder
- Subtractor
- Comparator
- Switch
- ATAN (arc tangent)
- Function block (any curve fitting, nonlinear function)
- 16-bit wide Logic operation (AND/OR/XOR/NOT/NEGATE)
- MCE™ program memory (3K byte)
- Dual port RAM (1K byte)
- MCE™ control sequencer
- 8051 microcontroller
 - 3 x 16 bit timer/counter
 - One 16-bit periodic timer
 - 16-bit analog watchdog timer
 - One 16-bit capture timer
 - Up to 36 discrete I/Os
 - Eleven-channel 12-bit A/D
 - Buffered five channels (0 – 1.2V input)
 - Unbuffered six channels (0 – 1.2V input)
 - JTAG port (4 pins)
 - Up to three channels of analog output (8-bit PWM)
 - 2 channel UART
 - I²C port
 - 48K byte Program RAM
 - 8K byte RAM

3 Pinout

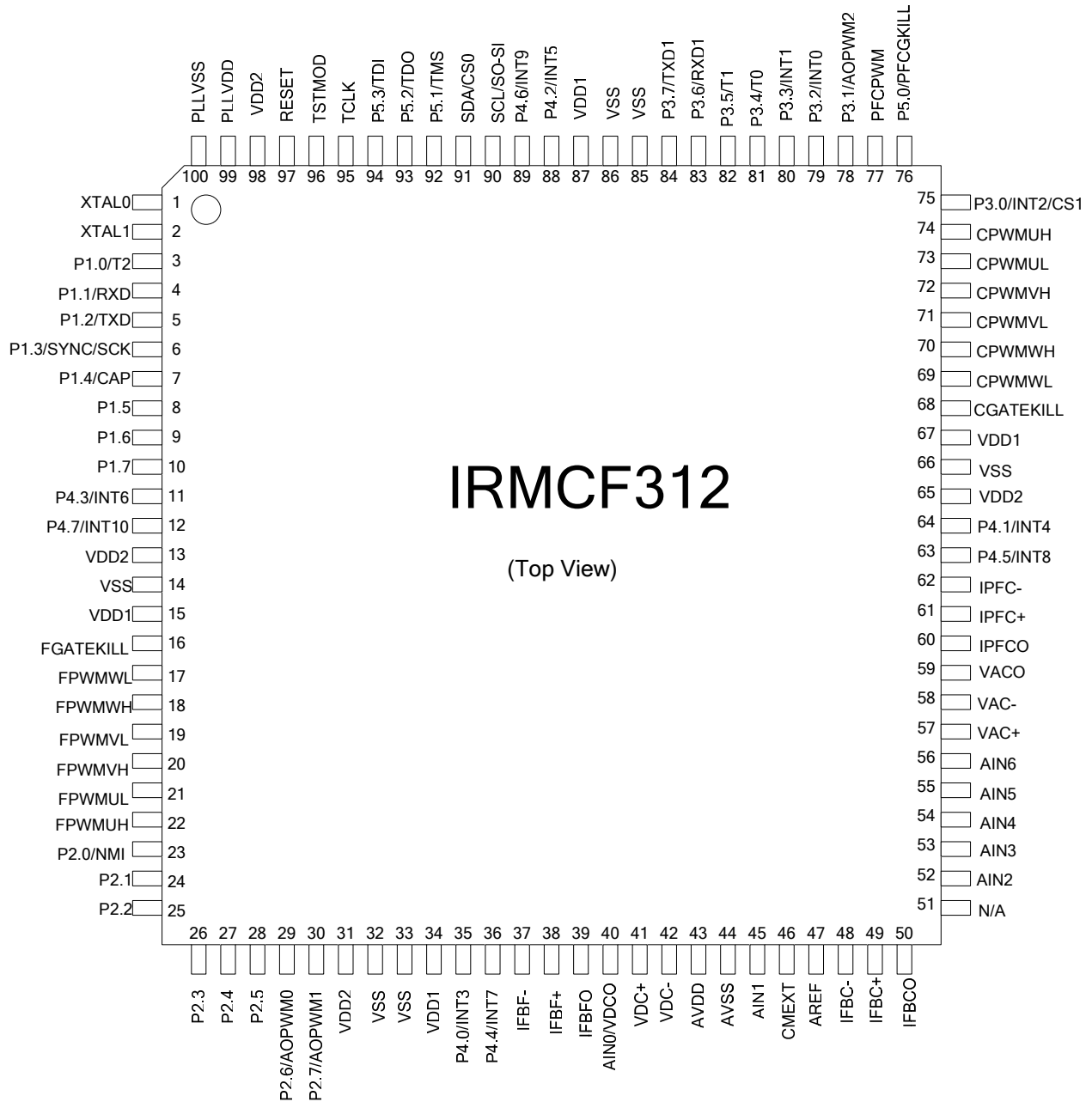

Figure 3. IRMCF312 Pin Configuration

4 4 Application Connections

Typical application connection is shown in Figure 4. In order to complete a Sensorless drive control, all necessary components are shown in connection to IRMCF312.

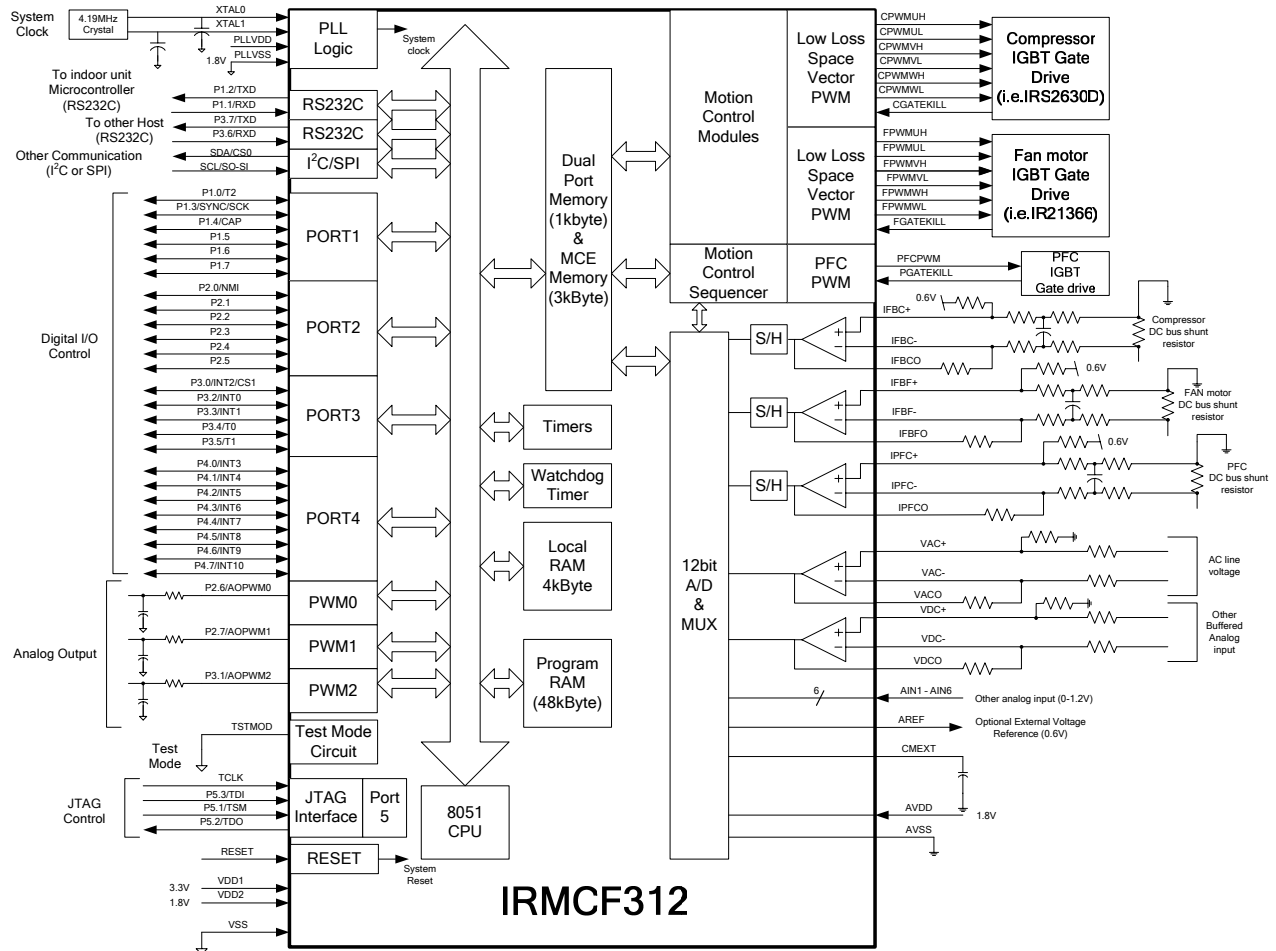
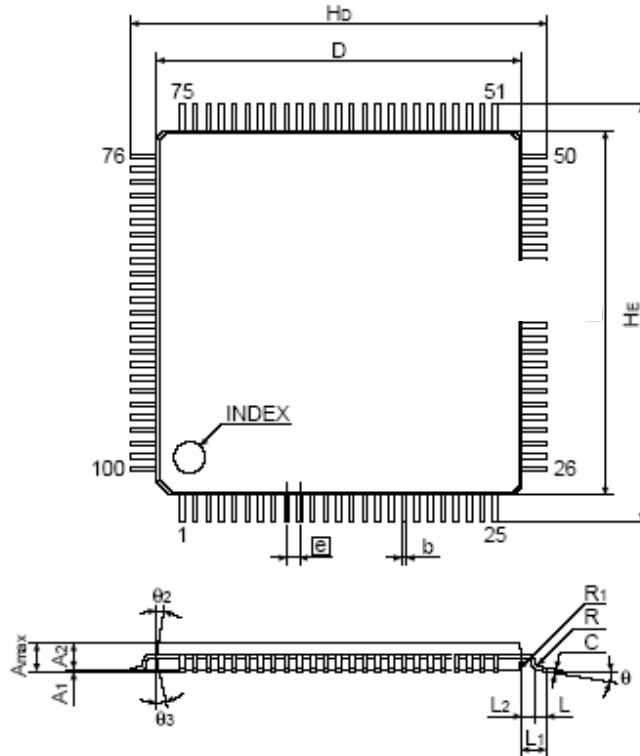

Figure 4. Application Connection of IRMCF312

Package Dimensions



Lead type STD (TQFP15-100pin STD)						
Symbol	Dimension in Millimeters			Dimension in Inches *		
	Min.	Nom.	Max.	Min.	Nom.	Max.
E	13.9	14	14.1	(0.548)	(0.551)	(0.555)
D	13.9	14	14.1	(0.548)	(0.551)	(0.555)
A			1.2			(0.047)
A ₁		0.1			(0.004)	
A ₂	0.9	1	1.1	(0.036)	(0.039)	(0.043)
e		0.5			(0.020)	
b	0.13	0.18	0.28	(0.006)	(0.007)	(0.011)
C	0.1	0.125	0.175	(0.004)	(0.005)	(0.006)
θ	0°		10°	(0°)		(10°)
L	0.3	0.5	0.7	(0.012)	(0.020)	(0.027)
L ₁		1			(0.039)	
L ₂		0.5			(0.020)	
H _E	15.6	16	16.4	(0.615)	(0.630)	(0.645)
H _D	15.6	16	16.4	(0.615)	(0.630)	(0.645)
θ_2		12°			(12°)	
θ_3		12°			(12°)	
R		0.2			(0.008)	
R ₁		0.2			(0.008)	

* for reference

International
IOR Rectifier

IR WORLD HEADQUARTERS: 233 Kansas St., El Segundo, California 90245, Tel: (310) 252-7105
<http://www.irf.com> *Data and specifications subject to change without notice. 9/15/2003*

Sales Offices, Agents and Distributors in Major Cities Throughout the World.