

LOW EMI CURRENT SENSE HIGH SIDE SWITCH

Features

- Load current feedback
- Programmable over current shutdown
- Active clamp
- ESD protection
- Input referenced to Vcc
- Over temperature shutdown
- Reverse battery protection
- Lead-Free

Description

The IR3315(S)PbF is a fully protected 4 terminals high side switch. The input signal is referenced to Vcc. When the input voltage $V_{cc} - V_{in}$ is higher than the specified threshold, the output power Mosfet is turned on. When the $V_{cc} - V_{in}$ is lower than the specified V_{il} threshold, the output Mosfet is turned off. A current proportional to the power Mosfet current is sourced to the Ifb pin. Over current shutdown occurs when $V_{st} - V_{in} > 4.5V$. The current shutdown threshold is adjusted by selecting the proper Rlfb. Either over current and over temperature latches off the switch. The device is reset by pulling the input pin high. Other integrated protections (ESD, reverse battery, active clamp) make the switch very rugged in automotive environment.

Typical Connection

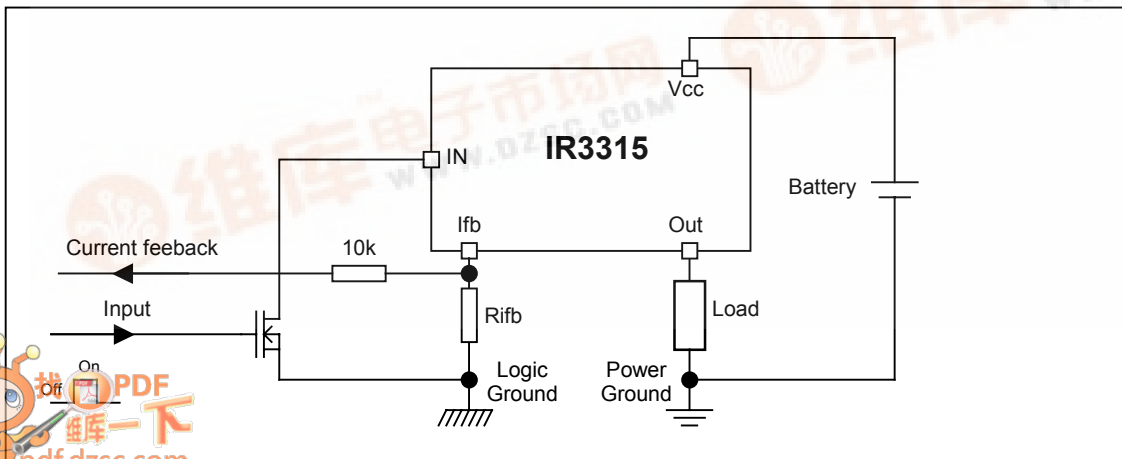

Product Summary

| | |
|-----------------|------------|
| Rds(on) | 20 mΩ max. |
| Vcc op. | 6 to 32V |
| Current Ratio | 2800 |
| Prog. Ishutdown | 3 to 30A |
| Vclamp | 40V |

Packages



TO-220
IR3315PbF

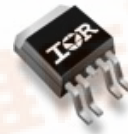

D²Pak
Pin 4 and 5 fused
IR3315SPbF

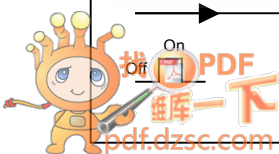

Absolute Maximum Ratings

Absolute maximum ratings indicate sustained limits beyond which damage to the device may occur. All voltage parameters are referenced to Vcc lead. (Tambient=25°C unless otherwise specified).

| Symbol | Parameter | Min. | Max. | Units |
|---------------|---|------|------|-------|
| Vcc-Vin | Maximum Vcc voltage | -16 | 37 | V |
| Vcc-Vin cont. | Maximum continuous Vcc voltage | -16 | 32 | |
| Vcc-Vfb | Maximum lfb voltage | -16 | 33 | |
| Vcc-Vout | Maximum output voltage | -0.3 | 37 | A |
| Ids cont. | Maximum body diode continuous current Rth=60°C/W (1) | — | 2.8 | |
| Ids pulsed | Maximum body diode pulsed current (1) | — | 100 | W |
| Pd | Maximum power dissipation Rth=60°C/W | — | 2 | |
| ESD1 | Electrostatic discharge voltage (Human body) C=100pF, R=1500Ω | — | 4 | kV |
| ESD2 | Electrostatic discharge voltage (Machine Model) C=200pF, R=0Ω | — | 0.5 | |
| Tj max. | Max. storage & operating temperature junction temperature | -40 | 150 | °C |
| Min Rfb | Minimum on the resistor on lfb pin | 0.3 | — | kΩ |
| lfb max. | Max. lfb current | -50 | 50 | mA |

(1) Limited by junction temperature. Pulsed is also limited by wiring

Thermal Characteristics

| Symbol | Parameter | Typ. | Max. | Units |
|--------|--|------|------|-------|
| Rth1 | Thermal resistance junction to ambient D ² -Pak Std footprint | 60 | — | °C/W |
| Rth2 | Thermal resistance junction to case D ² -Pak | 1.6 | — | |
| Rth3 | Thermal resistance junction to case TO-220 | 1.6 | — | |

Recommended Operating Conditions

These values are given for a quick design. For operation outside these conditions, please consult the application notes.

| Symbol | Parameter | Min. | Max. | Units | |
|------------|---------------------------------|------|-------------------------------------|-------|-----|
| Iout | Continuous output current | — | 14 | A | |
| | | | Tambient=85°C, Rth=5°C/W, Tj=125°C | | 3.9 |
| | | | Tambient=85°C, Rth=60°C/W, Tj=125°C | | — |
| Rifb | Recommended lfb resistor (2)(3) | 0.5 | 3.5 | kΩ | |
| Pulse min. | Minimum turn-on pulse width | 1 | — | ms | |
| Fmax. | Maximum operating frequency | — | 200 | Hz | |

2) If Rifb is too low, the device can be damaged.

3) If Rifb is too high, the device may not switch on.

Protection Characteristics

T_j=25°C, R_{ifb}=500 to 5kΩ

| Symbol | Parameter | Min. | Typ. | Max. | Units | Test Conditions |
|--------------------------|---------------------------------------|------|------|------|-------|--|
| V _{fb-Vin@Isd} | Over-current shutdown threshold | 4 | 4.7 | 5.6 | V | |
| T _{sd} | Over temperature threshold | — | 165 | — | °C | See fig. 5 |
| OV | Over voltage protection (not latched) | 33 | 35 | 39 | V | |
| Isdf | Fixed over current shutdown | 30 | 38 | 47 | A | V _{fb} <V _{fb-Vin@Isd} |
| Isd_1k | Programmable over current shutdown 1k | 9 | 12 | 16 | | R _{ifb} =1kΩ |
| T _{reset} | Time to reset protection | — | 50 | 500 | μs | See fig. 5 |
| Min. pulse | Min. pulse width (no WAIT state) | 200 | 400 | 1200 | | |
| WAIT | WAIT function timer | 0.4 | 1 | 2 | ms | See fig. 4 and 5 |
| R _{ds(on) rev.} | Reverse battery On state resistance | 10 | 16 | 28 | mΩ | V _{cc-Vin} =-14V, I _{out} =10A |

Static Electrical Characteristics

T_j=25°C, V_{cc}=14V (unless otherwise specified)

| Symbol | Parameter | Min. | Typ. | Max. | Units | Test Conditions |
|---------------------|---|------|------|------|-------|---|
| V _{cc op.} | Operating Voltage range | 6 | — | 32 | V | |
| I _{cc off} | Supply leakage current | — | 1.5 | 5 | μA | V _{in} =V _{cc} , V _{cc-Vout} =14V, V _{cc-Vifb} =14V |
| I _{in, on} | On state I _N positive current | 1.5 | 3 | 6 | mA | V _{cc-Vin} =14V |
| V _{ih} | High level Input threshold voltage (4) | — | 5.4 | 6.2 | V | |
| V _{il} | Low level Input threshold voltage (4) | 4 | 4.9 | 5.8 | | |
| V _{hyst} | Input hysteresis V _{ih} -V _{il} | 0.2 | 0.4 | 1 | | |
| I _{out} | Drain to source leakage current | — | 1.2 | 5 | μA | V _{in} =V _{cc} , V _{cc-Vifb} =0V, V _{cc-Vout} =14V |
| R _{ds(on)} | On state resistance (5) T _j =25°C | 10 | 15 | 20 | mΩ | V _{in} =10A, V _{cc-Vin} =14V |
| | On state resistance (5) T _j =25°C | 10 | 16 | 28 | | I _{out} =7A, V _{cc-Vin} =6V |
| | On state resistance (5) T _j =150°C | 20 | 28.5 | 38 | | I _{out} =10A, V _{cc-Vin} =14V |
| V _{clamp1} | V _{cc} to V _{out} clamp voltage 1 | 36 | 39 | — | V | I _{out} =50mA |
| V _{clamp2} | V _{cc} to V _{out} clamp voltage 2 | — | 40 | 43 | | I _{out} =10A |

(4) Input thresholds are measured directly between the input pin and the tab. Any parasitic resistance in common between the load current path and the input signal path can significantly affect the thresholds.

(5) R_{ds(on)} is measured between the tab and the Out pin, 5mm away from the package.

Switching Electrical Characteristics

V_{cc}=14V, Resistive load=4Ω, T_j=25°C

| Symbol | Parameter | Min. | Typ. | Max. | Units | Test Conditions |
|-------------------|---|------|------|------|-------|-----------------|
| T _{don} | Turn on delay time to 10% V _{cc} | 3 | 11 | 27 | μs | See figure 2 |
| Tr1 | Rise time to V _{cc-Vout} =5V | 1 | 4 | 10 | | |
| Tr2 | Rise time to V _{cc-Vout} =0.1V _{cc} | 2 | 8 | 20 | | |
| E _{on} | Turn on energy | — | 0.2 | — | mJ | |
| T _{doff} | Turn off delay time | 10 | 40 | 100 | μs | |
| T _f | Fall time to V _{out} =10% of V _{cc} | 2 | 8 | 20 | | |
| E _{off} | Turn off energy | — | 0.1 | — | mJ | |

Current Sense Characteristics

| Symbol | Parameter | Min. | Typ. | Max. | Units | Test Conditions |
|---------------------|---|-------|-------|-------|-------|--|
| Ratio | I Load/I _{fb} current ratio | 2,400 | 2,800 | 3,200 | — | T _j =25°C, R _{fb} =500Ω, I _{out} =20A |
| Ratio _{TC} | I Load/I _{fb} variation aver temperature | -5 | — | +5 | % | T _j =-40°C to 150°C |
| Offset | Load current diagnostic offset | -0.08 | 0 | +0.07 | A | I _{out} =1A |
| Trst | I _{fb} response time (low signal) | — | 1 | — | μs | 90% of the I _{out} step |

Functional Block Diagram

All values are typical

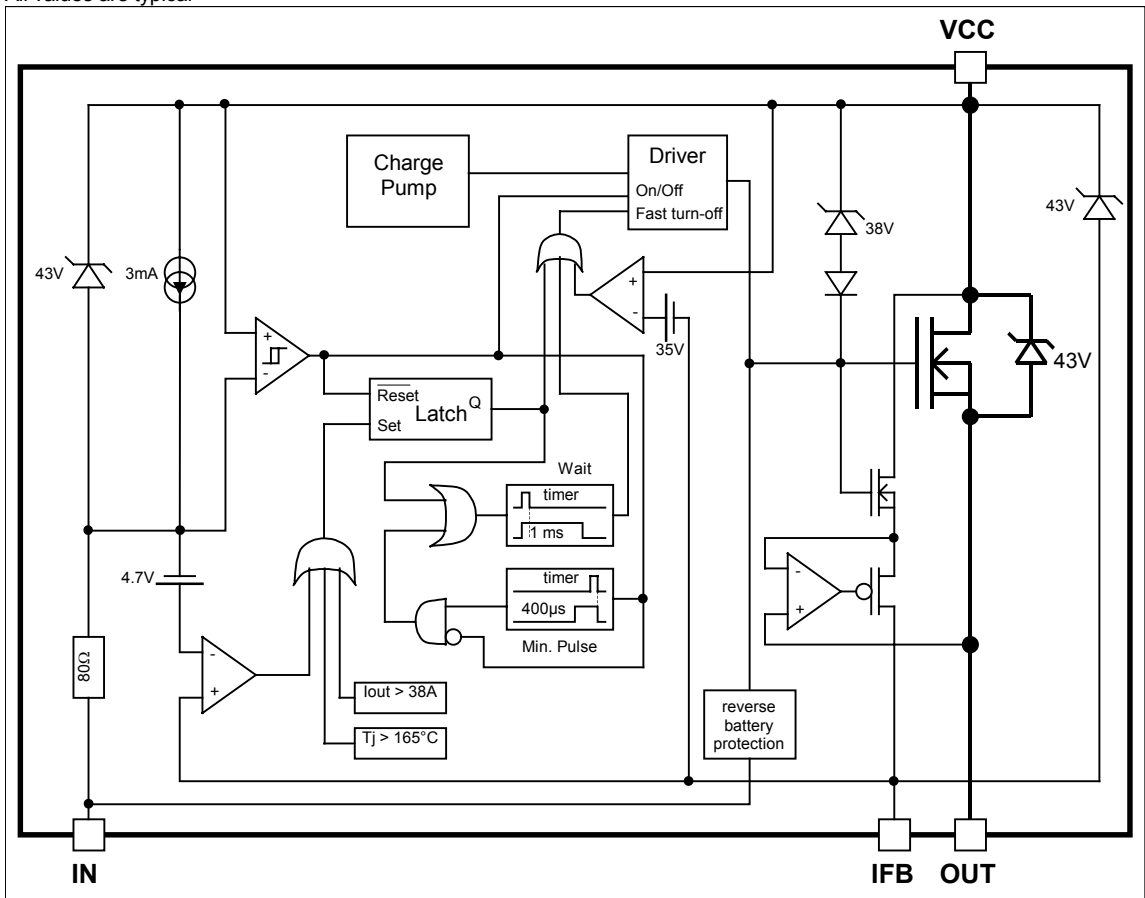

Lead Assignments

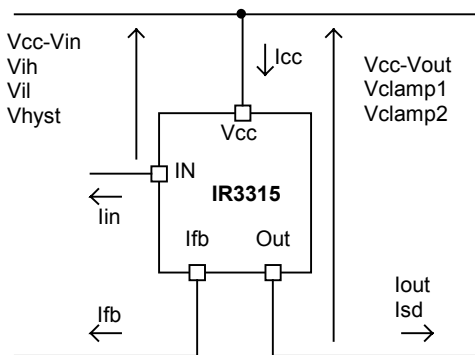
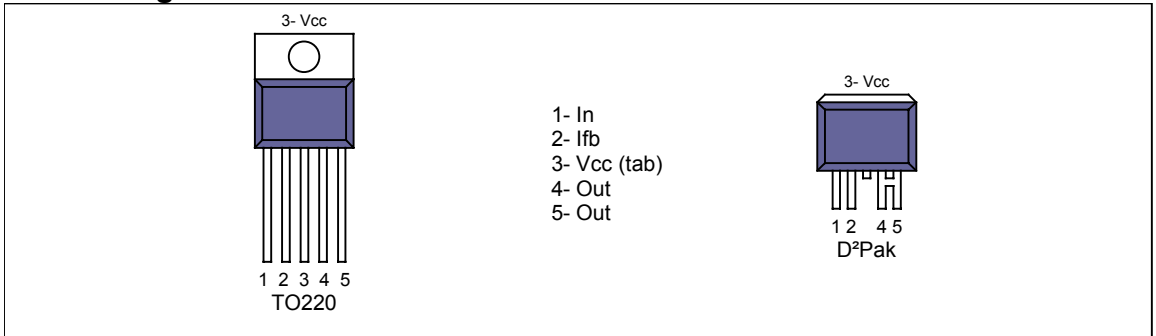

Figure 1 – Voltages and current definitions

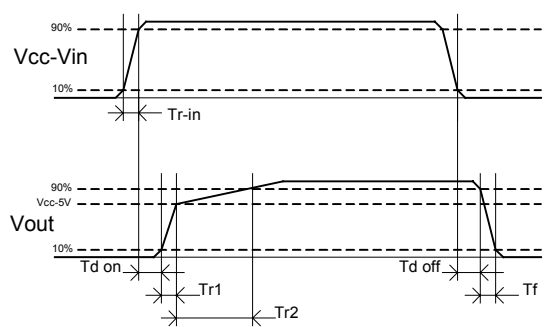

Figure 2 – Switching time definitions

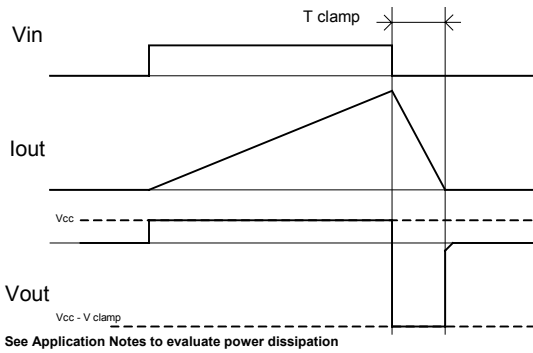

Figure 3 – Active clamp waveforms

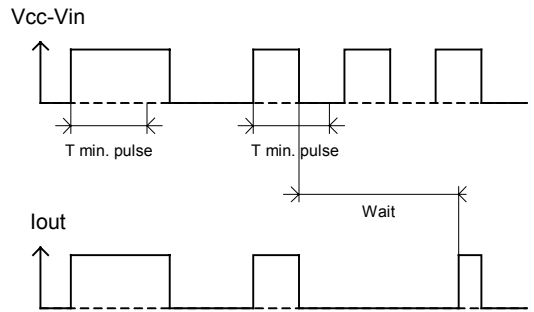

Figure 4 – Min. pulse and Wait function

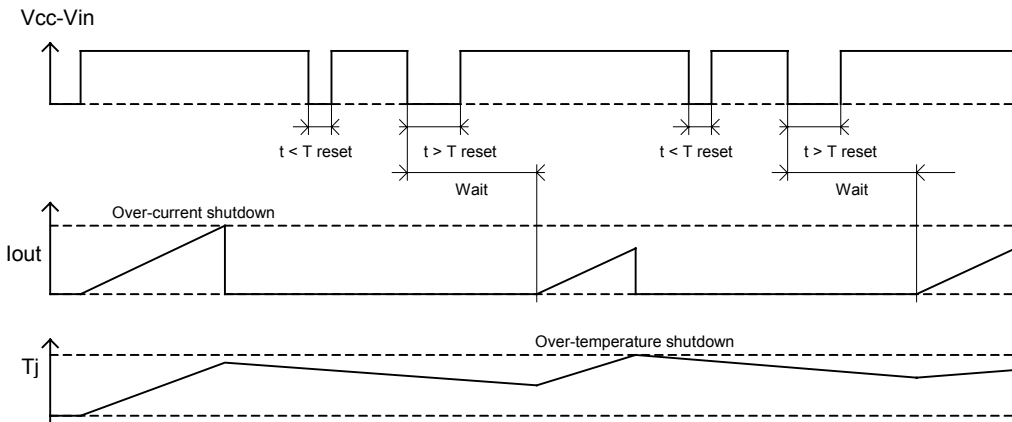

Figure 5 – Protection Timing Diagrams

All curves are typical characteristics. Operation in hatched areas is not recommended. $T_j=25^{\circ}\text{C}$, $R_{ifb}=500\text{ohm}$, $V_{cc}=14\text{V}$ (unless otherwise specified).

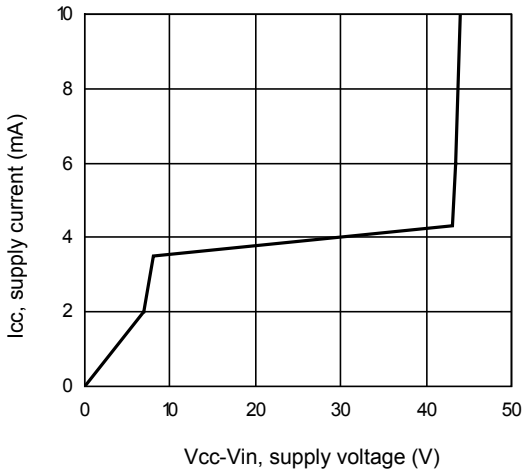

Figure 6 – Icc (mA) Vs Vcc-Vin (V)

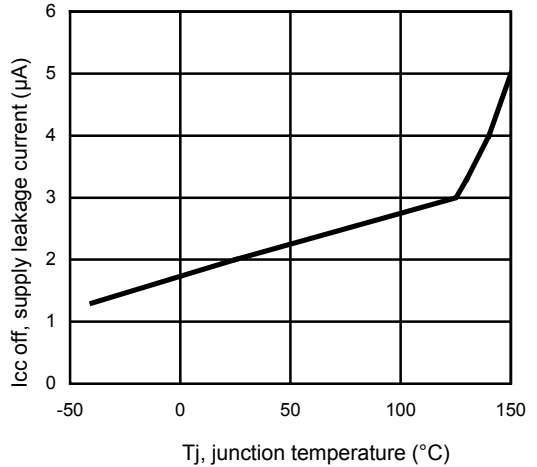

Figure 7 – Icc off (µA) Vs Tj (°C)

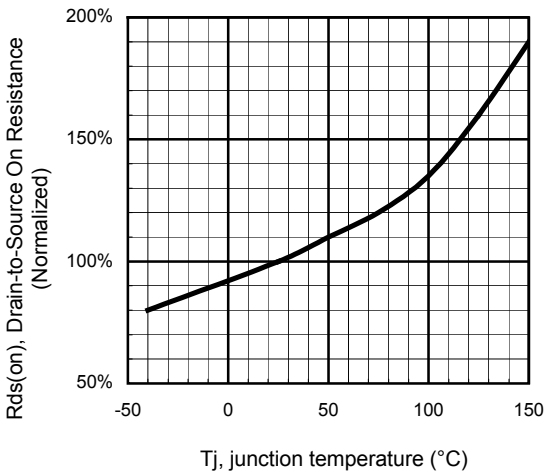

Figure 8 - Normalized Rds(on) (%) Vs Tj (°C)

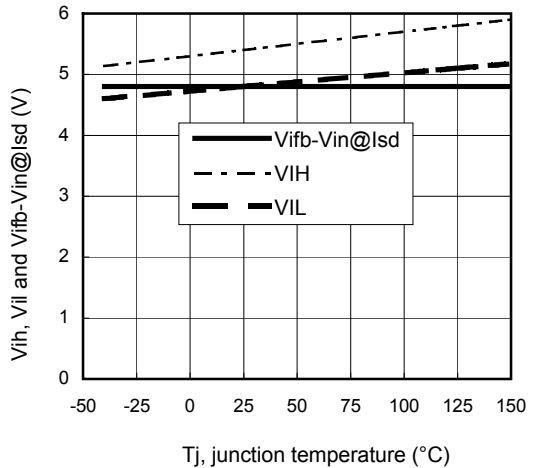

Figure 9 – Vih, Vil and Vifb-Vin@Isd (V) Vs Tj (°C)

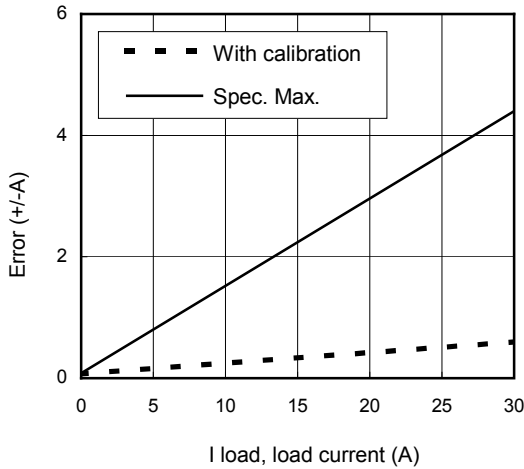

Figure 10 – Error (+/- A) Vs I load (A)

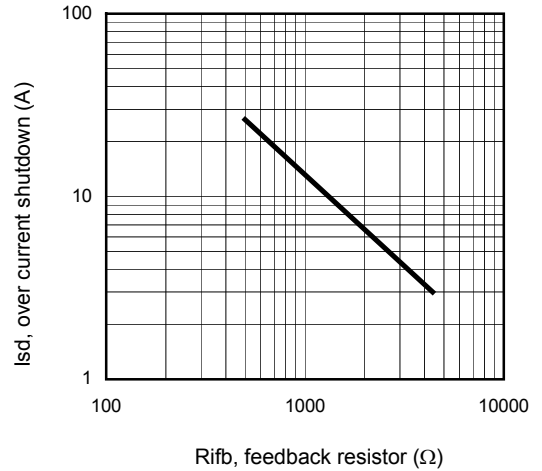

Figure 11 – Ids (A) Vs Rifb (Ω)

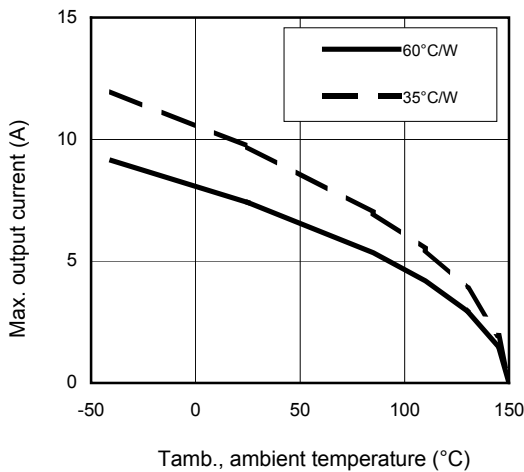

Figure 12 – Max. iout (A) Vs Tamb. (°C)

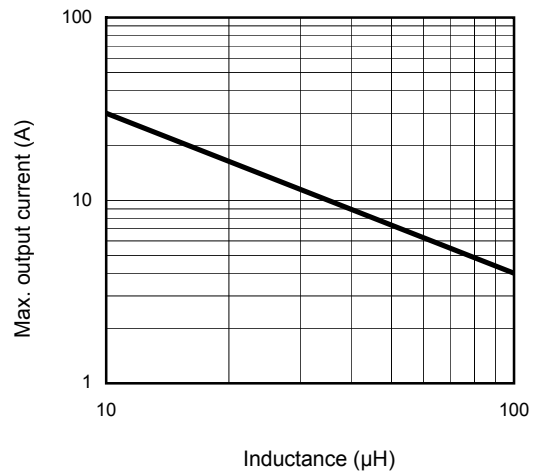

Figure 13 – Max. iout (A) Vs inductance (μH)

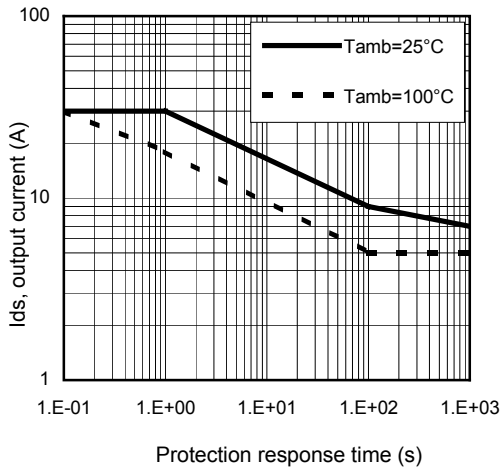

Figure 14 – I_{ds} (A) Vs over temperature protection response time (s)

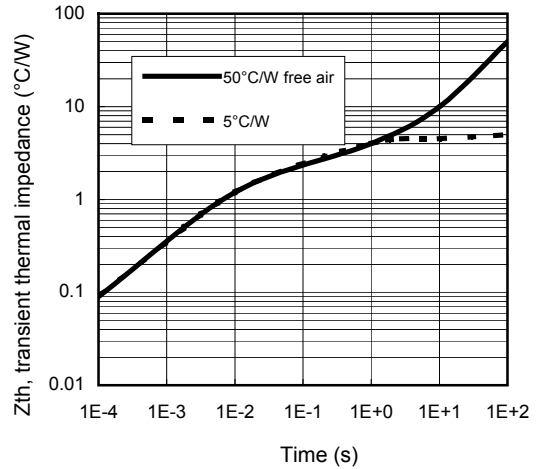
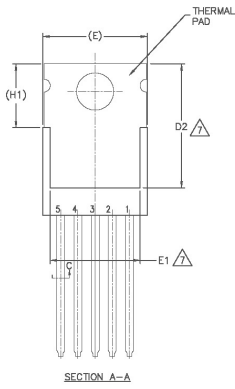
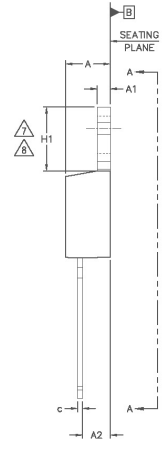
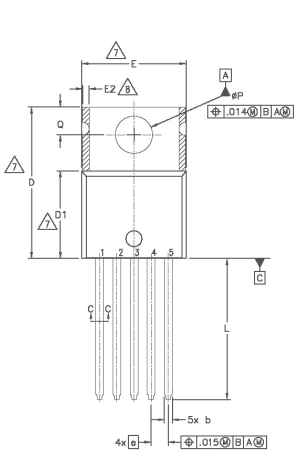
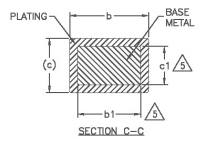

Figure 15 – Transient thermal impedance (°C/W) Vs time (s)

Case Outline – TO220 5 leads - Automotive Q100 PbF qualified



| SYMBOL | DIMENSIONS | | | | NOTES |
|--------|-------------|-------|----------|------|-------|
| | MILLIMETERS | | INCHES | | |
| | MIN. | MAX. | MIN. | MAX. | |
| A | 3.56 | 4.83 | .140 | .190 | 5 |
| A1 | 0.51 | 1.40 | .020 | .055 | |
| A2 | 2.03 | 2.92 | .080 | .115 | |
| b | 0.64 | 0.89 | .025 | .035 | |
| b1 | 0.64 | 0.84 | .025 | .033 | |
| c | 0.36 | 0.61 | .014 | .024 | 5 |
| c1 | 0.36 | 0.56 | .014 | .022 | |
| D | 14.22 | 16.51 | .560 | .650 | 4 |
| D1 | 8.36 | 9.02 | .330 | .355 | 7 |
| D2 | 11.68 | 12.88 | .460 | .507 | |
| E | 9.65 | 10.67 | .380 | .420 | 4,7 |
| E1 | 6.86 | 8.89 | .270 | .350 | 7 |
| E2 | - | 0.76 | - | .030 | 8 |
| e | 1.70 BSC | | .067 BSC | | 7,8 |
| H1 | 5.84 | 6.86 | .230 | .270 | |
| L | 12.70 | 14.73 | .500 | .580 | |
| ØP | 3.53 | 3.73 | .139 | .147 | |
| Q | 2.54 | 3.05 | .100 | .120 | |



- NOTES:
- 1.- DIMENSIONING AND TOLERANCING AS PER ASME Y14.5 M-1994.
 - 2.- DIMENSIONS ARE SHOWN IN INCHES [MILLIMETERS].
 - 3.- LEAD DIMENSION AND FINISH UNCONTROLLED IN L1.
 - 4.- DIMENSION D, D1 & E DO NOT INCLUDE MOLD FLASH. MOLD FLASH SHALL NOT EXCEED .005" (0.127) PER SIDE. THESE DIMENSIONS ARE MEASURED AT THE OUTERMOST EXTREMES OF THE PLASTIC BODY.
 - 5.- DIMENSION b1 & c1 APPLY TO BASE METAL ONLY.
 - 6.- CONTROLLING DIMENSION - INCHES.
 - 7.- THERMAL PAD CONTOUR OPTIONAL WITHIN DIMENSIONS E,H1,D2 & E1
 - 8.- DIMENSION E2 X H1 DEFINE A ZONE WHERE STAMPING AND SINGULATION IRREGULARITIES ARE ALLOWED.
 - 9.- OUTLINE CONFORMS TO JEDEC TO-220, EXCEPT A2 (max.) AND D2 (min.) WHERE DIMENSIONS ARE DERIVED FROM THE ACTUAL PACKAGE OUTLINE.
 - 10.- LEADS AND DRAIN ARE PLATED WITH 100% Sn

Case Outline 5 Lead - D2PAK - Automotive Q100 PbF MSL1 qualified

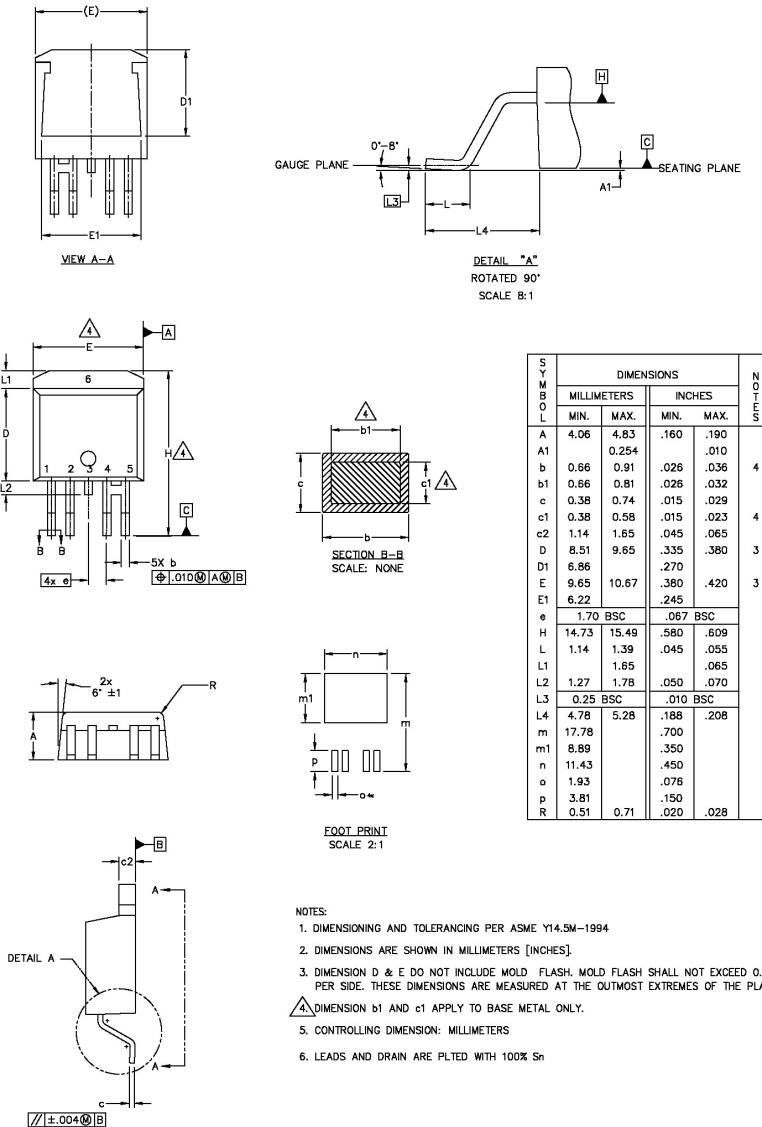

Tape & Reel 5 Lead - D2PAK

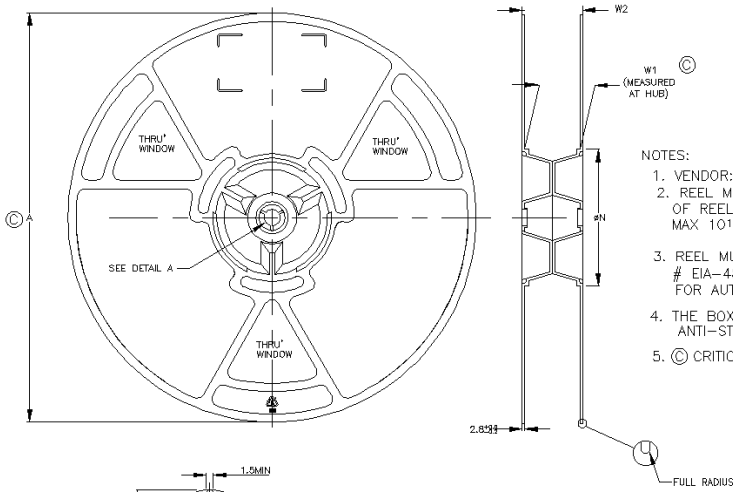

- NOTES:
1. VENDOR: OPTIONAL
 2. REEL MUST HAVE ANTI-STATIC COATING SURFACE RESISTIVITY OF REEL (AS PER EIA-541) min: 10^9 ohm/SQUARE; MAX: 10^{12} ohm/SQUARE
 3. REEL MUST ALSO MEET REQUIREMENTS OF EIA STANDARD # EIA-481A, TAPING OF SURFACE-MOUNT COMPONENTS FOR AUTOMATIC PLACEMENT.
 4. THE BOX OF PACKING MUST CONTAIN THE REELS INSIDE AN ANTI-STATIC BAG.
 5. Ⓢ CRITICAL

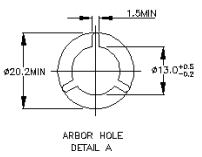

- Ⓢ A MAX = 3.30
- Ⓢ N MAX = 100
- W1 = 24.4 ± 0.3
- W2 MAX = 30.4

