

Driver IC

Laser Diodes Driver IC

Sharp manufactures a series of driver ICs (IR3C01/R3C01/R3C01N, IR3C02A/IR2C02AN) for use as laser diode APC circuits. Using these ICs, the power output of the laser is easily adjusted by means of an external resistance. Specifications are as follows:

IR3C01/IR3C01N, IR3C02A/IR3C02AN Pin Assignment

Pin No.	IR3C01/IR3C01N		IR3C02A/IR3C02AN	
	symbol	Function	Symbol	Function
1	OUT	Out	OUT	Output
2	Im	Monitor input	GND	Ground
3	Vaj	Output Setting	Im	Monitor Input
4	VEE	(-) Power Supply	VEE	(-)Power Supply
5	VIN	Control Input (on/off)	VIN	Control Input (on/off)
6	GND	Ground	So	Operating signal output
7	Cp	Phase Compensation	Cp	Phase Compensation
8	Vcc	(+) Power Supply	Vcc	(+) Power Supply



8pin DIP
IR3C01/IR3C02A

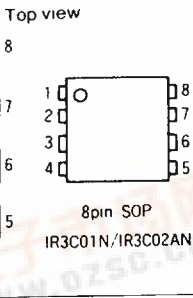

8pin SOP
IR3C01N/IR3C02AN

Absolute Maximum Ratings

(Ta=25°C)

Parameter	Symbol	Remarks	Ratings		Units
			IR3C01/IR3C01N	IR3C02A/IR3C02AN	
Supply Voltage	Vcc		13	10	V
Supply Voltage	VEE		-20	-10	V
Output Current	Io	Pin ①	170	-170	mA
Control Input Voltage	VIN	Pin ⑤	-0.2 to 6	-0.2 to Vcc	V
Power Dissipation	Pc	Ta ≤ 25°C	450/330	550/500	mW
Derating ratio	—	Ta > 25°C	4.6/3.3	4.4	mW/°C
Operating Temperature	Topr		-20 to +85	-30 to +85	°C
Storage Temperature	Tstg		-55 to +150	-55 to +150	°C
Output Current	Ios	Pin ⑥ with laser on	—	5	mA
Output Applied Voltage	Vos	Pin ⑥ with laser off	—	-0.2-Vcc	V

Electrical Characteristics

(a) IR3C01/IR3C01N

(Vcc = -5V, VEE = -12V, Ta = 25°C)

Parameter	Symbol	Condition	Rating			Units
			MIN	TYP	MAX	
Operating Supply Voltage	Vcc	—	4.5	5.0	5.5	V
	VEE	—	-10.0	-12.0	-13.2	
Circuit Current	Icc	VIN = 0V	—	2.8	4.5	mA
	IEE OFF	VIN = 0V	—	-1.3	-2.1	
	IEE ON	VIN = 5V	—	-2.8	-4.6	
Output Voltage	VOUT	Io = 150mA	3.6	4.1	—	V
		Io = 100mA	3.7	4.2	—	
		Io = 20mA	3.8	4.3	—	
Control Input Voltage (H)	VINH	—	2.0	—	6	V
Control Input Voltage (L)	VINL	—	0	—	0.8	V
Control Input Current	IIN	VIN = 5V	—	0.3	0.5	mA
Monitor Input pin Voltage	VM	—	—	-6.9	—	V
Output Adjustment Pin Voltage	Vaj	(Vaj - VEE)	3.5	3.9	4.3	V
Power Supply Ripple Reduction	ΔIo/ΔVcc	f = 120Hz	—	4 × 10 ⁻⁵	—	A/V
	ΔIo/ΔVEE	—	—	1 × 10 ⁻⁶	—	

(b) IR3C02A/IR3C02AN

(Vcc = 5V, VEE = -5V, Ta = 25°C)

Parameter	Symbol	Condition	Rating			Units	
			MIN	TYP	MAX		
Operating Supply Voltage	Vcc	—	4.5	5.0	5.5	V	
	VEE	—	-4.5	-5.0	-5.5		
Circuit Current	Icc ON	VIN = 5V	—	2.8	5.0	mA	
	IEE ON	—	—	-2.0	-5.0		
	Icc OFF	VIN = 0V	—	4.1	7.5		
	IEE OFF	—	—	-2.1	-3.8		
Output Voltage	VOUT	Io = -150mA	3.7	4.1	—	V	
		Io = -100mA	3.8	4.2	—		
		Io = -20mA	3.9	4.3	—		
Output Voltage	VOS1	Ios = 0mA	—	0.05	—	V	
		VOS2	Ios = 2mA	—	0.4		—
Control Voltage	H	VIN H	Vo Vos L → H	1.43	1.53	1.63	V
	L	VIN L	Vo Vos H → L	1.23	1.33	1.43	
Control Voltage Hysteresis	VIN HY	(VIN H - VIN L)	—	200	—	mV	
Control Input Current	IIN	—	—	-0.3	—	μA	
Monitor Input Pin Voltage	V	—	1.16	1.22	1.28	V	
Monitor Input Pin Current	I	—	—	-0.3	-5	μA	
Photo output power supply change	ΔP/ΔVcc	VEE = -5V, Vcc = 5V ± 10%	—	0.02	—	% / V	
	ΔP/ΔVEE	Vcc = -5V, VEE = -5V ± 10%	—	0.2	—		
Photo output changing width	ΔP/IPO	Ta = -30 to +85°C	—	0.2	—	%	



Common Data

Fig. 94-1 Optical Power Output Dependence of Far-Field Pattern

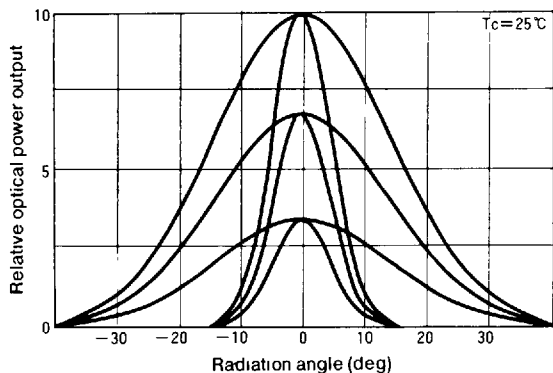

Fig. 94-4 Coupling Efficiency

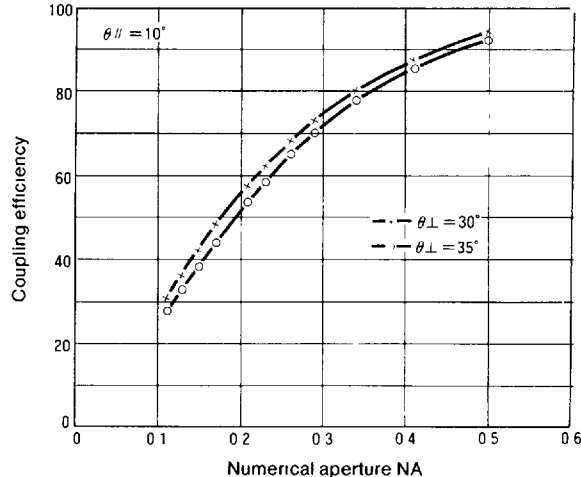

Fig. 94-2 Polarization Ratio vs. Optical Power Output (LT026 series, LT023 series)

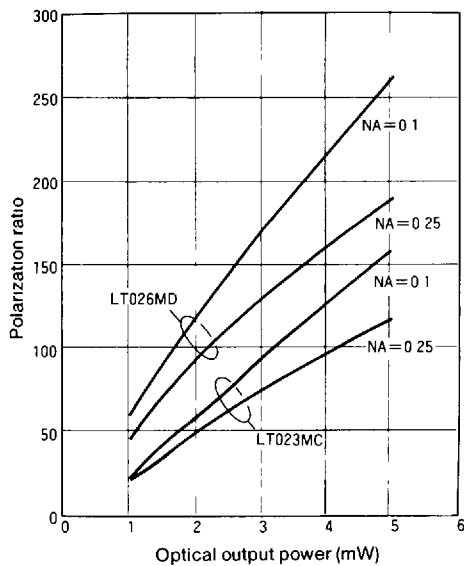

Fig. 94-5 Frequency Response

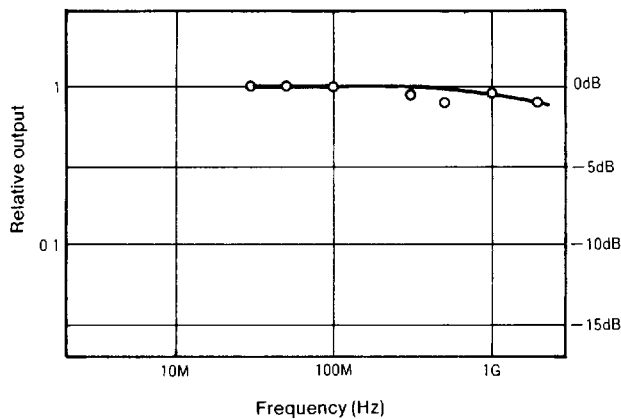
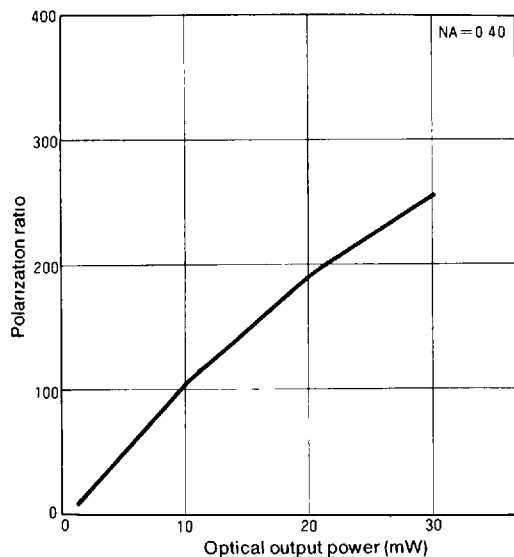

Fig. 94-3 Polarization Ratio vs. Optical Power Output (LT024 series, LT015 series)



Note: All data on this page is typical only, and is not intended as a specification. The shapes of these curves can be used as a general reference, but the actual characteristics will vary from device to device.

Built-in PIN Photodiode Characteristics

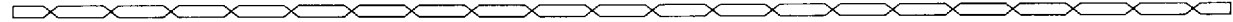

Fig. 95-1 Photodiode Frequency Response Characteristic

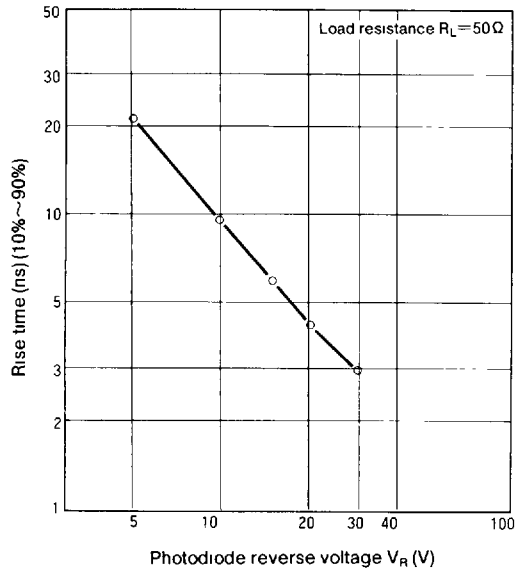
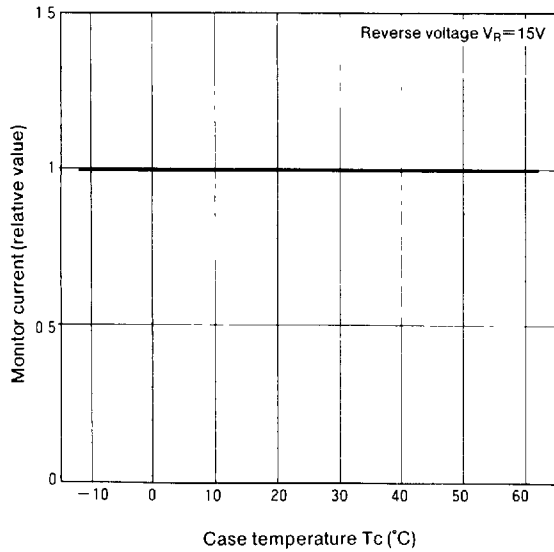

Fig. 95-2 Photodiode Temperature Characteristic



Note: All data on this page is typical only, and is not intended as a specification. The shapes of these curves can be used as a general reference, but the actual characteristics will vary from device to device.

Outline Dimensions

Unit: mm

Fig. 98-1 Standard Type (C Type)

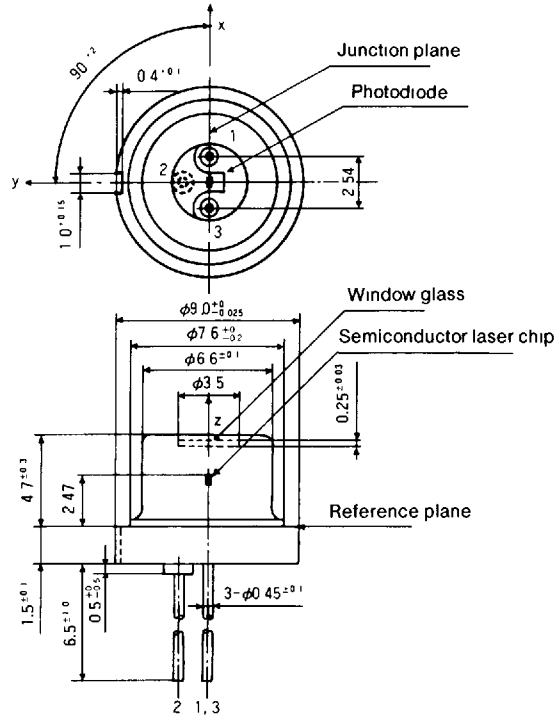

Fig. 98-2 Low-Cap Type (D Type)

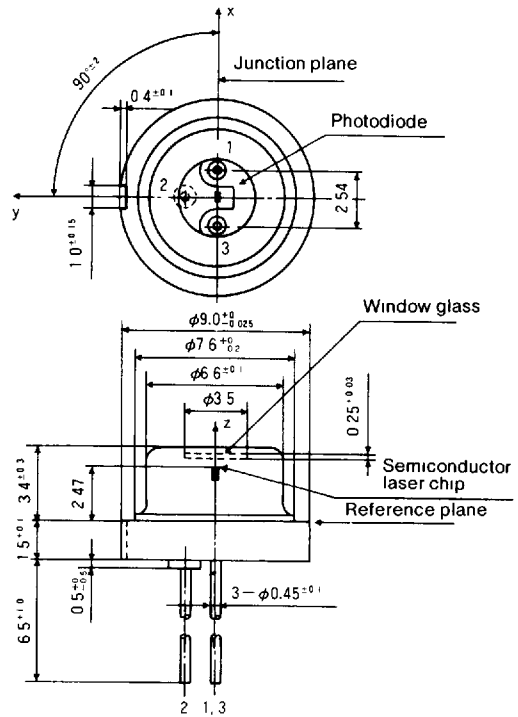

Fig. 98-3 Fin-Equipped Type (F Type)

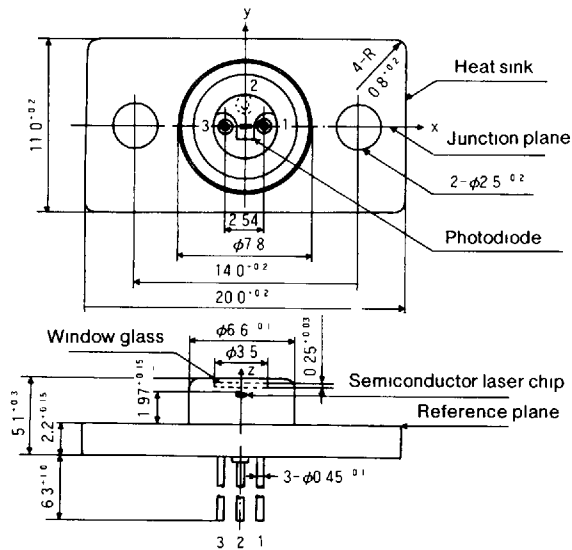
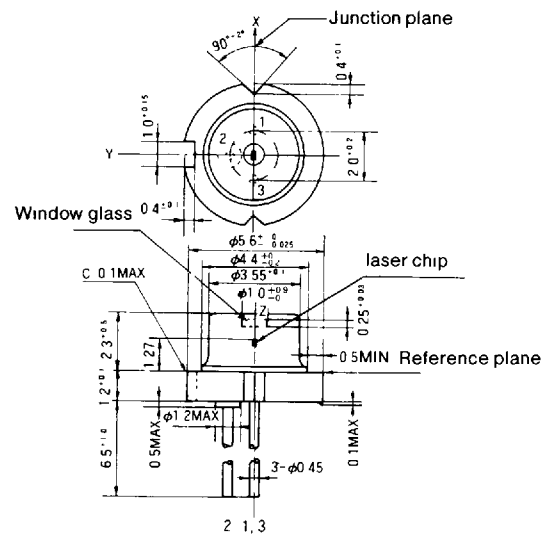

Fig. 98-4 Compact Package Type (S Type)



Terminal connections

