

The SN5405 is obsolete and no longer is supplied.

# SN54LS05, SN54S05, SN7405, SN74LS05, SN74S05 HEX INVERTERS WITH OPEN-COLLECTOR OUTPUTS

SDLS030A – DECEMBER 1983 – REVISED NOVEMBER 2003

- Package Options Include Plastic Small-Outline (D, NS), Shrink Small-Outline (DB), and Ceramic Flat (W) Packages, Ceramic Chip Carriers (FK), and Standard Plastic (N) and Ceramic (J) DIPs

- Dependable Texas Instrument Quality and Reliability

SN5405, SN54LS05, SN54S05 . . . J PACKAGE  
SN7405 . . . N PACKAGE

SN74LS05 . . . D, DB, N, OR NS PACKAGE  
SN74S05 . . . D, N, OR NS PACKAGE

(TOP VIEW)

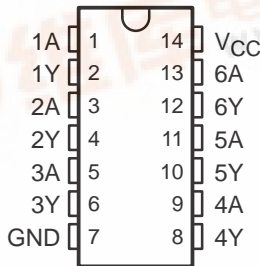

SN54LS05, SN54S05 . . . W PACKAGE  
(TOP VIEW)

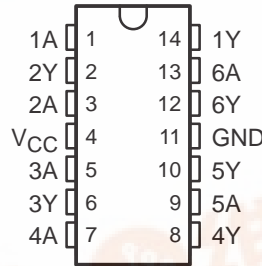

SN54LS05, SN54S05 . . . FK PACKAGE  
(TOP VIEW)

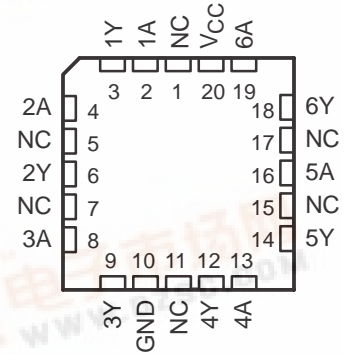

NC – No internal connection

## description/ordering information

These devices contain six independent inverters. To perform correctly, the open-collector outputs require pullup resistors. These devices may be connected to other open-collector outputs to implement active-low wired-OR or active-high wire-AND functions. Open-collector devices often are used to generate high V<sub>OH</sub> levels.

## ORDERING INFORMATION

TA	PACKAGE†		ORDERABLE PART NUMBER	TOP-SIDE MARKING	
0°C to 70°C	PDIP – N	Tube	SN7405N	SN7405N	
			SN74LS05N	SN74LS05N	
			SN74S05N	SN74S05N	
	SOIC – D	Tube	SN74LS05D	LS05	
			SN74LS05DR		
			Tape and reel	SN74S05D	S05
				SN74S05DR	
	SOP – NS	Tape and reel	SN74LS05NSR	74LS05	
SN74S05NSR			74S05		
SSOP – DB	Tape and reel	SN74LS05DBR	LS05		
–55°C to 125°C	CDIP – J	Tube	SNJ54LS05J	SNJ54LS05J	
			SNJ54S05J	SNJ54S05J	
	CDIP – W	Tube	SNJ54LS05W	SNJ54LS05W	
			SNJ54S05W	SNJ54S05W	
	LCCC – FK	Tube	SNJ54LS05FK	SNJ54LS05FK	
			SNJ54S05FK	SNJ54S05FK	

† Package drawings, standard packing quantities, thermal data, symbolization, and PCB design guidelines are available at [www.ti.com/sc/package](http://www.ti.com/sc/package).

Please be aware that an important notice concerning availability, standard warranty, and use in critical applications of Texas Instruments semiconductor products and disclaimers thereto appears at the end of this data sheet.



PRODUCTION DATA information is current as of publication date. Products conform to specifications per the terms of Texas Instruments standard warranty. Production processing does not necessarily include testing of all parameters.



Copyright © 2003, Texas Instruments Incorporated  
On products compliant to MIL-PRF-38535, all parameters are tested unless otherwise noted. On all other products, production processing does not necessarily include testing of all parameters.

**SN54LS05, SN54S05**  
**SN7405, SN74LS05, SN74S05**  
**HEX INVERTERS WITH OPEN-COLLECTOR OUTPUTS**  
SDLS030A – DECEMBER 1983 – REVISED NOVEMBER 2003

The SN5405 is obsolete  
and no longer is supplied.

FUNCTION TABLE  
(each inverter)

INPUT A	OUTPUT Y
H	L
L	H

logic diagram (positive logic)

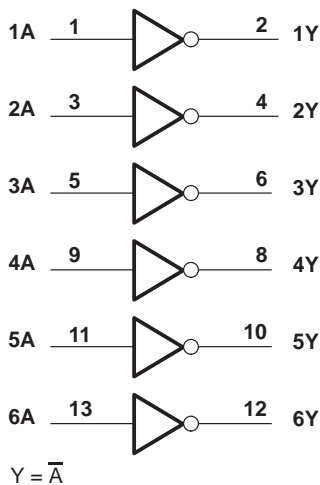

Pin numbers shown are for the D, DB, J, N, and NS packages.

The SN5405 is obsolete and no longer is supplied.

# SN54LS05, SN54S05 SN7405, SN74LS05, SN74S05 HEX INVERTERS WITH OPEN-COLLECTOR OUTPUTS

SDLS030A – DECEMBER 1983 – REVISED NOVEMBER 2003

## schematic (each inverter)

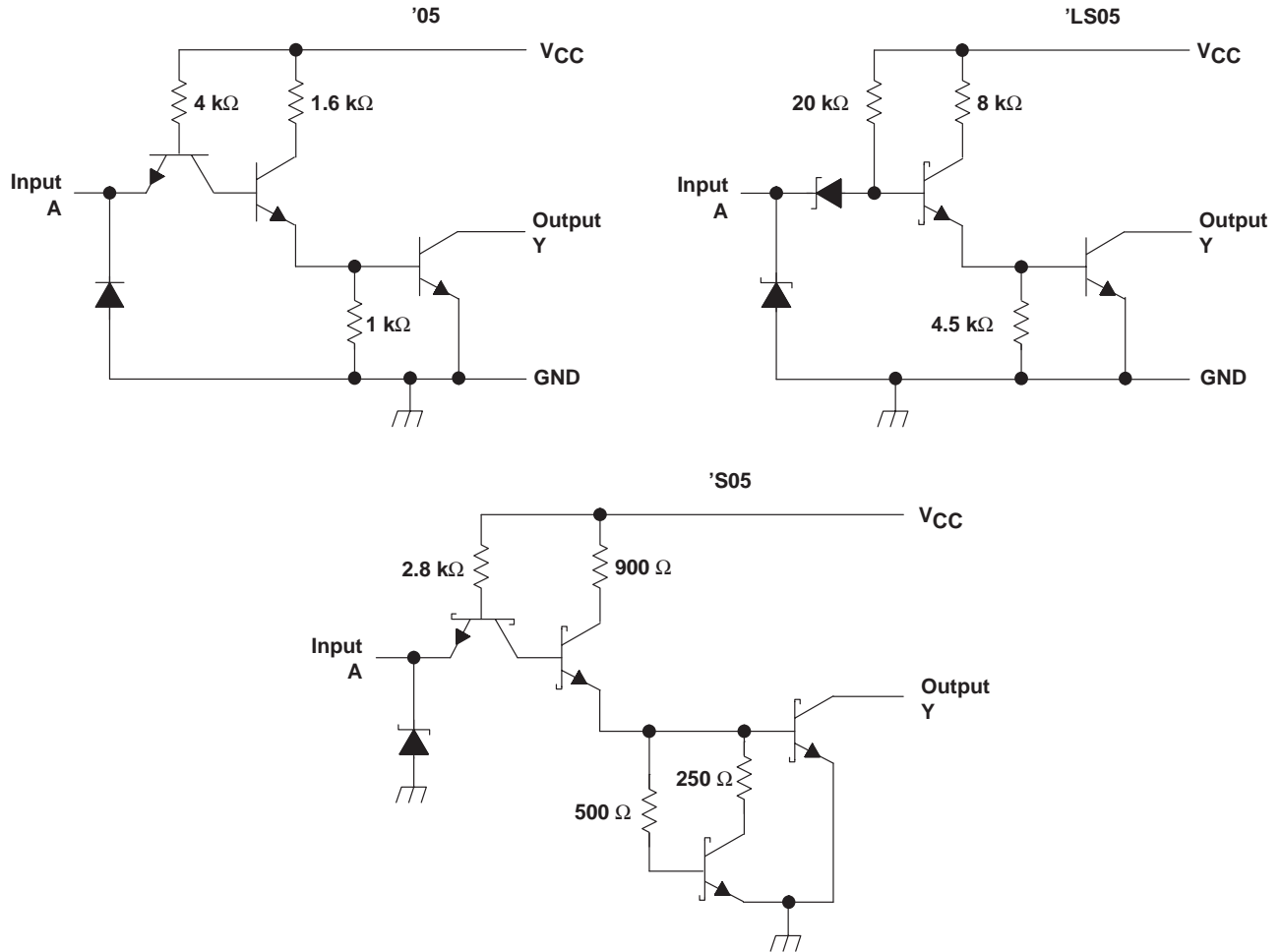

Resistor values shown are nominal.

## absolute maximum ratings over operating free-air temperature (unless otherwise noted)†

Supply voltage, $V_{CC}$ (see Note 1): '05, 'LS05, 'S05	7 V
Input voltage, $V_I$ : '05, 'S05	5.5 V
'LS05	7 V
Off-state output voltage, $V_O$	7 V
Package thermal impedance, $\theta_{JA}$ (see Note 2): D package	86°C/W
DB package	96°C/W
N package	80°C/W
NS package	76°C/W
Storage temperature range, $T_{Stg}$	-65°C to 150°C

† Stresses beyond those listed under "absolute maximum ratings" may cause permanent damage to the device. These are stress ratings only, and functional operation of the device at these or any other conditions beyond those indicated under "recommended operating conditions" is not implied. Exposure to absolute-maximum-rated conditions for extended periods may affect device reliability.

- NOTES: 1. Voltage values are with respect to network ground terminal.  
2. The package thermal impedance is calculated in accordance with JESD 51-7.

**SN54LS05, SN54S05  
SN7405, SN74LS05, SN74S05  
HEX INVERTERS WITH OPEN-COLLECTOR OUTPUTS**

SDLS030A – DECEMBER 1983 – REVISED NOVEMBER 2003

The SN5405 is obsolete and no longer is supplied.

**recommended operating conditions**

	SN5405			SN7405			UNIT
	MIN	NOM	MAX	MIN	NOM	MAX	
V <sub>CC</sub> Supply voltage	4.5	5	5.5	4.75	5	5.25	V
V <sub>IH</sub> High-level input voltage	2			2			V
V <sub>IL</sub> Low-level input voltage			0.8			0.8	V
V <sub>OH</sub> High-level output voltage			5.5			5.5	V
I <sub>OL</sub> Low-level output current			16			16	mA
T <sub>A</sub> Operating free-air temperature	-55		125	0		70	°C

**electrical characteristics over recommended operating free-air temperature range (unless otherwise noted)**

PARAMETER	TEST CONDITIONS†		SN5405			SN7405			UNIT
			MIN	TYP‡	MAX	MIN	TYP‡	MAX	
V <sub>IK</sub>	V <sub>CC</sub> = MIN,	I <sub>I</sub> = -12 mA			-1.5			-1.5	V
I <sub>OH</sub>	V <sub>CC</sub> = MIN,	V <sub>OH</sub> = 5.5 V						0.25	mA
		V <sub>IL</sub> = 0.8 V V <sub>IL</sub> = 0.7 V			0.25				
V <sub>OL</sub>	V <sub>CC</sub> = MIN,	V <sub>IH</sub> = 2 V, I <sub>OL</sub> = 16 mA	0.2	0.4		0.2	0.4	V	
I <sub>I</sub>	V <sub>CC</sub> = MAX,	V <sub>I</sub> = 5.5 V			1			1	mA
I <sub>IH</sub>	V <sub>CC</sub> = MAX,	V <sub>I</sub> = 2.4 V			40			40	µA
I <sub>IL</sub>	V <sub>CC</sub> = MAX,	V <sub>I</sub> = 0.4 V			-1.6			-1.6	mA
I <sub>CCH</sub>	V <sub>CC</sub> = MAX,	V <sub>I</sub> = 0 V	6	12		6	12	mA	
I <sub>CCL</sub>	V <sub>CC</sub> = MAX,	V <sub>I</sub> = 4.5 V	18	33		18	33	mA	

† For conditions shown as MIN or MAX, use the appropriate value specified under recommended operating conditions.

‡ All typical values are at V<sub>CC</sub> = 5 V, T<sub>A</sub> = 25°C.

**switching characteristics, V<sub>CC</sub> = 5 V, T<sub>A</sub> = 25°C (see Figure 1)**

PARAMETER	FROM (INPUT)	TO (OUTPUT)	TEST CONDITIONS		MIN	TYP	MAX	UNIT
t <sub>PLH</sub>	A	Y	R <sub>L</sub> = 4 kΩ	C <sub>L</sub> = 15 pF		40	55	ns
t <sub>PHL</sub>			R <sub>L</sub> = 400 Ω			8	15	

The SN5405 is obsolete  
and no longer is supplied.

**SN54LS05, SN54S05**  
**SN7405, SN74LS05, SN74S05**  
**HEX INVERTERS WITH OPEN-COLLECTOR OUTPUTS**

SDLS030A – DECEMBER 1983 – REVISED NOVEMBER 2003

**recommended operating conditions**

	SN54LS05			SN74LS05			UNIT
	MIN	NOM	MAX	MIN	NOM	MAX	
V <sub>CC</sub> Supply voltage	4.5	5	5.5	4.75	5	5.25	V
V <sub>IH</sub> High-level input voltage	2			2			V
V <sub>IL</sub> Low-level input voltage			0.7			0.8	V
V <sub>OH</sub> High-level output voltage			5.5			5.5	V
I <sub>OL</sub> Low-level output current			4			8	mA
T <sub>A</sub> Operating free-air temperature	-55		125	0		70	°C

**electrical characteristics over recommended operating free-air temperature range (unless otherwise noted)**

PARAMETER	TEST CONDITION <sup>†</sup>		SN54LS05		SN74LS05		UNIT	
			MIN	TYP <sup>‡</sup>	MAX	MIN		TYP <sup>‡</sup>
V <sub>IK</sub>	V <sub>CC</sub> = MIN,	I <sub>I</sub> = -18 mA		-1.5		-1.5	V	
I <sub>OH</sub>	V <sub>CC</sub> = MIN,	V <sub>IL</sub> = MAX, V <sub>OH</sub> = 5.5 V		0.1		0.1	mA	
V <sub>OL</sub>	V <sub>CC</sub> = MIN,	V <sub>IH</sub> = 2 V	I <sub>OL</sub> = 4 mA	0.25	0.4	0.25	0.4	V
			I <sub>OL</sub> = 8 mA			0.35	0.5	
I <sub>I</sub>	V <sub>CC</sub> = MAX,	V <sub>I</sub> = 7 V		0.1		0.1	mA	
I <sub>IH</sub>	V <sub>CC</sub> = MAX,	V <sub>I</sub> = 2.7 V		20		20	μA	
I <sub>IL</sub>	V <sub>CC</sub> = MAX,	V <sub>I</sub> = 0.4 V		-0.4		-0.4	mA	
I <sub>CCH</sub>	V <sub>CC</sub> = MAX,	V <sub>I</sub> = 0 V		1.2	2.4	1.2	2.4	mA
I <sub>CCL</sub>	V <sub>CC</sub> = MAX,	V <sub>I</sub> = 4.5 V		3.6	6.6	3.6	6.6	mA

<sup>†</sup> For conditions shown as MIN or MAX, use the appropriate value specified under recommended operating conditions.

<sup>‡</sup> All typical values are at V<sub>CC</sub> = 5 V, T<sub>A</sub> = 25°C.

**switching characteristics, V<sub>CC</sub> = 5 V, T<sub>A</sub> = 25°C (see Figure 2)**

PARAMETER	FROM (INPUT)	TO (OUTPUT)	TEST CONDITIONS	MIN	TYP	MAX	UNIT
t <sub>PLH</sub>	A	Y	R <sub>L</sub> = 2 kΩ, C <sub>L</sub> = 15 pF		17	32	ns
t <sub>PHL</sub>					15	28	

**SN54LS05, SN54S05  
SN7405, SN74LS05, SN74S05  
HEX INVERTERS WITH OPEN-COLLECTOR OUTPUTS**

SDLS030A – DECEMBER 1983 – REVISED NOVEMBER 2003

The SN5405 is obsolete and no longer is supplied.

**recommended operating conditions**

	SN54S05			SN74S05			UNIT
	MIN	NOM	MAX	MIN	NOM	MAX	
V <sub>CC</sub> Supply voltage	4.5	5	5.5	4.75	5	5.25	V
V <sub>IH</sub> High-level input voltage	2			2			V
V <sub>IL</sub> Low-level input voltage			0.8			0.8	V
V <sub>OH</sub> High-level output voltage			5.5			5.5	V
I <sub>OL</sub> Low-level output current			20			20	mA
T <sub>A</sub> Operating free-air temperature	-55		125	0		70	°C

**electrical characteristics over recommended operating free-air temperature range (unless otherwise noted)**

PARAMETER	TEST CONDITIONS†		SN54S05			SN74S05			UNIT	
			MIN	TYP‡	MAX	MIN	TYP‡	MAX		
V <sub>IK</sub>	V <sub>CC</sub> = MIN,	I <sub>I</sub> = -18 mA			-1.2			-1.2	V	
I <sub>OH</sub>	V <sub>CC</sub> = MIN,	V <sub>OH</sub> = 5.5 V						0.25	mA	
		V <sub>IL</sub> = 0.8 V								
		V <sub>IL</sub> = 0.7 V			0.25					
V <sub>OL</sub>	V <sub>CC</sub> = MIN,	V <sub>IH</sub> = 2 V, I <sub>OL</sub> = 20 mA			0.5			0.5	V	
I <sub>I</sub>	V <sub>CC</sub> = MAX,	V <sub>I</sub> = 5.5 V			1			1	mA	
I <sub>IH</sub>	V <sub>CC</sub> = MAX,	V <sub>I</sub> = 2.7 V			50			50	µA	
I <sub>IL</sub>	V <sub>CC</sub> = MAX,	V <sub>I</sub> = 0.5 V			-2			-2	mA	
I <sub>CCH</sub>	V <sub>CC</sub> = MAX,	V <sub>I</sub> = 0 V			9	19.8		9	19.8	mA
I <sub>CCL</sub>	V <sub>CC</sub> = MAX,	V <sub>I</sub> = 4.5 V			30	54		30	54	mA

† For conditions shown as MIN or MAX, use the appropriate value specified under recommended operating conditions.

‡ All typical values are at V<sub>CC</sub> = 5 V, T<sub>A</sub> = 25°C.

**switching characteristics, V<sub>CC</sub> = 5 V, T<sub>A</sub> = 25°C (see Figure 1)**

PARAMETER	FROM (INPUT)	TO (OUTPUT)	TEST CONDITIONS		MIN	TYP	MAX	UNIT
t <sub>PLH</sub>	A	Y	R <sub>L</sub> = 280 Ω	C <sub>L</sub> = 15 pF	2	5	7.5	ns
t <sub>PHL</sub>					2	4.5	7	
t <sub>PLH</sub>				C <sub>L</sub> = 50 pF	7.5	ns		
t <sub>PHL</sub>					7			

The SN5405 is obsolete and no longer is supplied.

**SN54LS05, SN54S05**  
**SN7405, SN74LS05, SN74S05**  
**HEX INVERTERS WITH OPEN-COLLECTOR OUTPUTS**  
 SDLS030A – DECEMBER 1983 – REVISED NOVEMBER 2003

**PARAMETER MEASUREMENT INFORMATION**  
**SERIES 54/74 AND 54S/74S DEVICES**

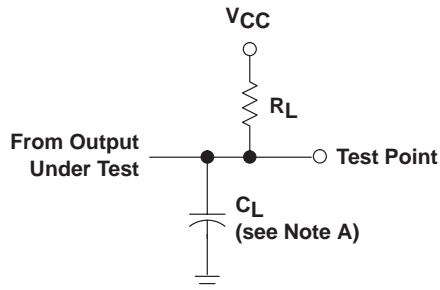

LOAD CIRCUIT

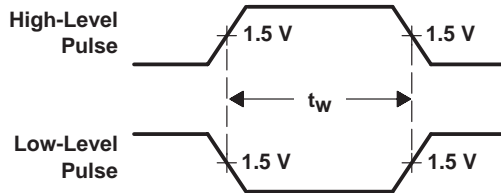

VOLTAGE WAVEFORMS  
PULSE WIDTHS

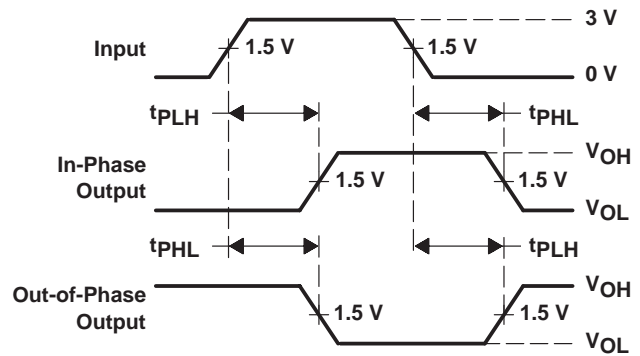

VOLTAGE WAVEFORMS  
PROPAGATION DELAY TIMES

- NOTES: A.  $C_L$  includes probe and jig capacitance.  
 B. In the examples above, the phase relationships between inputs and outputs have been chosen arbitrarily.  
 C. All input pulses are supplied by generators having the following characteristics:  $PRR \leq 1$  MHz,  $Z_O = 50 \Omega$ , and:  
 For Series 54/74,  $t_r \leq 7$  ns,  $t_f \leq 7$  ns.  
 For Series 54S/74S,  $t_r \leq 2.5$  ns,  $t_f \leq 2.5$  ns.  
 D. The outputs are measured one at a time with one input transition per measurement.

Figure 1. Load Circuit and Voltage Waveforms

**SN54LS05, SN54S05**  
**SN7405, SN74LS05, SN74S05**  
**HEX INVERTERS WITH OPEN-COLLECTOR OUTPUTS**  
 SDLS030A – DECEMBER 1983 – REVISED NOVEMBER 2003

The SN5405 is obsolete and no longer is supplied.

**PARAMETER MEASUREMENT INFORMATION**  
**SERIES 54LS/74LS DEVICES**

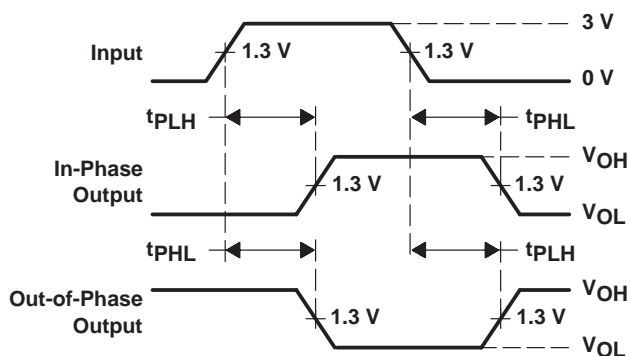
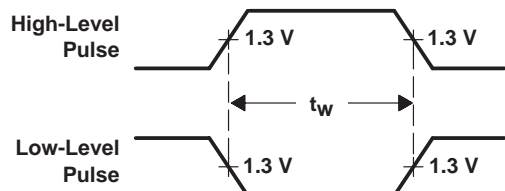
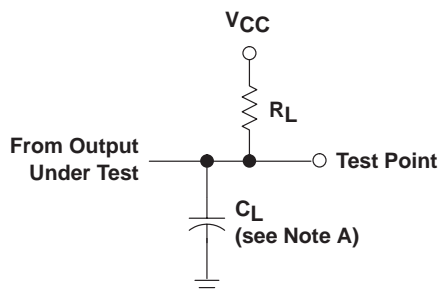

- NOTES: A.  $C_L$  includes probe and jig capacitance.  
 B. In the examples above, the phase relationships between inputs and outputs have been chosen arbitrarily.  
 C. All input pulses are supplied by generators having the following characteristics:  $PRR \leq 1 \text{ MHz}$ ,  $Z_O = 50 \Omega$ ,  $t_r \leq 1.5 \text{ ns}$ ,  $t_f \leq 2.6 \text{ ns}$ .  
 D. The outputs are measured one at a time with one input transition per measurement.

**Figure 2. Load Circuit and Voltage Waveforms**



**PACKAGING INFORMATION**

Orderable Device	Status <sup>(1)</sup>	Package Type	Package Drawing	Pins	Package Qty	Eco Plan <sup>(2)</sup>	Lead/Ball Finish	MSL Peak Temp <sup>(3)</sup>
JM38510/07003BDA	ACTIVE	CFP	W	14	1	TBD	A42	N / A for Pkg Type
JM38510/07004BCA	ACTIVE	CDIP	J	14	1	TBD	A42 SNPB	N / A for Pkg Type
SN54LS05J	ACTIVE	CDIP	J	14	1	TBD	A42 SNPB	N / A for Pkg Type
SN54S05J	ACTIVE	CDIP	J	14	1	TBD	A42 SNPB	N / A for Pkg Type
SN7405D	OBSOLETE	SOIC	D	14		TBD	Call TI	Call TI
SN7405DR	OBSOLETE	SOIC	D	14		TBD	Call TI	Call TI
SN7405N	ACTIVE	PDIP	N	14	25	Pb-Free (RoHS)	CU NIPDAU	N / A for Pkg Type
SN7405N3	OBSOLETE	PDIP	N	14		TBD	Call TI	Call TI
SN7405NE4	ACTIVE	PDIP	N	14	25	Pb-Free (RoHS)	CU NIPDAU	N / A for Pkg Type
SN74LS05D	ACTIVE	SOIC	D	14	50	Green (RoHS & no Sb/Br)	CU NIPDAU	Level-1-260C-UNLIM
SN74LS05DBLE	OBSOLETE	SSOP	DB	14		TBD	Call TI	Call TI
SN74LS05DBR	ACTIVE	SSOP	DB	14	2000	Green (RoHS & no Sb/Br)	CU NIPDAU	Level-1-260C-UNLIM
SN74LS05DBRE4	ACTIVE	SSOP	DB	14	2000	Green (RoHS & no Sb/Br)	CU NIPDAU	Level-1-260C-UNLIM
SN74LS05DE4	ACTIVE	SOIC	D	14	50	Green (RoHS & no Sb/Br)	CU NIPDAU	Level-1-260C-UNLIM
SN74LS05DR	ACTIVE	SOIC	D	14	2500	Green (RoHS & no Sb/Br)	CU NIPDAU	Level-1-260C-UNLIM
SN74LS05DRE4	ACTIVE	SOIC	D	14	2500	Green (RoHS & no Sb/Br)	CU NIPDAU	Level-1-260C-UNLIM
SN74LS05N	ACTIVE	PDIP	N	14	25	Pb-Free (RoHS)	CU NIPDAU	N / A for Pkg Type
SN74LS05N3	OBSOLETE	PDIP	N	14		TBD	Call TI	Call TI
SN74LS05NE4	ACTIVE	PDIP	N	14	25	Pb-Free (RoHS)	CU NIPDAU	N / A for Pkg Type
SN74LS05NSR	ACTIVE	SO	NS	14	2000	Green (RoHS & no Sb/Br)	CU NIPDAU	Level-1-260C-UNLIM
SN74LS05NSRG4	ACTIVE	SO	NS	14	2000	Green (RoHS & no Sb/Br)	CU NIPDAU	Level-1-260C-UNLIM
SN74S05D	ACTIVE	SOIC	D	14	50	Green (RoHS & no Sb/Br)	CU NIPDAU	Level-1-260C-UNLIM
SN74S05DE4	ACTIVE	SOIC	D	14	50	Green (RoHS & no Sb/Br)	CU NIPDAU	Level-1-260C-UNLIM
SN74S05DR	ACTIVE	SOIC	D	14	2500	Green (RoHS & no Sb/Br)	CU NIPDAU	Level-1-260C-UNLIM
SN74S05DRE4	ACTIVE	SOIC	D	14	2500	Green (RoHS & no Sb/Br)	CU NIPDAU	Level-1-260C-UNLIM
SN74S05N	ACTIVE	PDIP	N	14	25	Pb-Free (RoHS)	CU NIPDAU	N / A for Pkg Type
SN74S05N3	OBSOLETE	PDIP	N	14		TBD	Call TI	Call TI
SN74S05NE4	ACTIVE	PDIP	N	14	25	Pb-Free (RoHS)	CU NIPDAU	N / A for Pkg Type
SN74S05NSR	ACTIVE	SO	NS	14	2000	Green (RoHS & no Sb/Br)	CU NIPDAU	Level-1-260C-UNLIM

Orderable Device	Status <sup>(1)</sup>	Package Type	Package Drawing	Pins	Package Qty	Eco Plan <sup>(2)</sup>	Lead/Ball Finish	MSL Peak Temp <sup>(3)</sup>
SN74S05NSRE4	ACTIVE	SO	NS	14	2000	Green (RoHS & no Sb/Br)	CU NIPDAU	Level-1-260C-UNLIM
SNJ54LS05FK	ACTIVE	LCCC	FK	20	1	TBD	POST-PLATE	N / A for Pkg Type
SNJ54LS05J	ACTIVE	CDIP	J	14	1	TBD	A42 SNPB	N / A for Pkg Type
SNJ54LS05W	ACTIVE	CFP	W	14	1	TBD	A42	N / A for Pkg Type
SNJ54S05FK	ACTIVE	LCCC	FK	20	1	TBD	POST-PLATE	N / A for Pkg Type
SNJ54S05J	ACTIVE	CDIP	J	14	1	TBD	A42 SNPB	N / A for Pkg Type
SNJ54S05W	ACTIVE	CFP	W	14	1	TBD	A42	N / A for Pkg Type

<sup>(1)</sup> The marketing status values are defined as follows:

**ACTIVE:** Product device recommended for new designs.

**LIFEBUY:** TI has announced that the device will be discontinued, and a lifetime-buy period is in effect.

**NRND:** Not recommended for new designs. Device is in production to support existing customers, but TI does not recommend using this part in a new design.

**PREVIEW:** Device has been announced but is not in production. Samples may or may not be available.

**OBSELETE:** TI has discontinued the production of the device.

<sup>(2)</sup> Eco Plan - The planned eco-friendly classification: Pb-Free (RoHS), Pb-Free (RoHS Exempt), or Green (RoHS & no Sb/Br) - please check <http://www.ti.com/productcontent> for the latest availability information and additional product content details.

**TBD:** The Pb-Free/Green conversion plan has not been defined.

**Pb-Free (RoHS):** TI's terms "Lead-Free" or "Pb-Free" mean semiconductor products that are compatible with the current RoHS requirements for all 6 substances, including the requirement that lead not exceed 0.1% by weight in homogeneous materials. Where designed to be soldered at high temperatures, TI Pb-Free products are suitable for use in specified lead-free processes.

**Pb-Free (RoHS Exempt):** This component has a RoHS exemption for either 1) lead-based flip-chip solder bumps used between the die and package, or 2) lead-based die adhesive used between the die and leadframe. The component is otherwise considered Pb-Free (RoHS compatible) as defined above.

**Green (RoHS & no Sb/Br):** TI defines "Green" to mean Pb-Free (RoHS compatible), and free of Bromine (Br) and Antimony (Sb) based flame retardants (Br or Sb do not exceed 0.1% by weight in homogeneous material)

<sup>(3)</sup> MSL, Peak Temp. -- The Moisture Sensitivity Level rating according to the JEDEC industry standard classifications, and peak solder temperature.

**Important Information and Disclaimer:** The information provided on this page represents TI's knowledge and belief as of the date that it is provided. TI bases its knowledge and belief on information provided by third parties, and makes no representation or warranty as to the accuracy of such information. Efforts are underway to better integrate information from third parties. TI has taken and continues to take reasonable steps to provide representative and accurate information but may not have conducted destructive testing or chemical analysis on incoming materials and chemicals. TI and TI suppliers consider certain information to be proprietary, and thus CAS numbers and other limited information may not be available for release.

In no event shall TI's liability arising out of such information exceed the total purchase price of the TI part(s) at issue in this document sold by TI to Customer on an annual basis.

J (R-GDIP-T\*\*)

14 LEADS SHOWN

CERAMIC DUAL IN-LINE PACKAGE

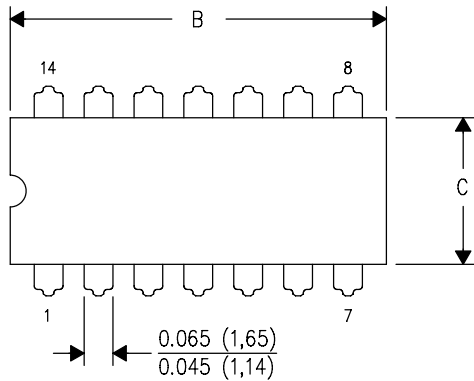

DIM \ PINS **	14	16	18	20
A	0.300 (7,62) BSC	0.300 (7,62) BSC	0.300 (7,62) BSC	0.300 (7,62) BSC
B MAX	0.785 (19,94)	.840 (21,34)	0.960 (24,38)	1.060 (26,92)
B MIN	—	—	—	—
C MAX	0.300 (7,62)	0.300 (7,62)	0.310 (7,87)	0.300 (7,62)
C MIN	0.245 (6,22)	0.245 (6,22)	0.220 (5,59)	0.245 (6,22)

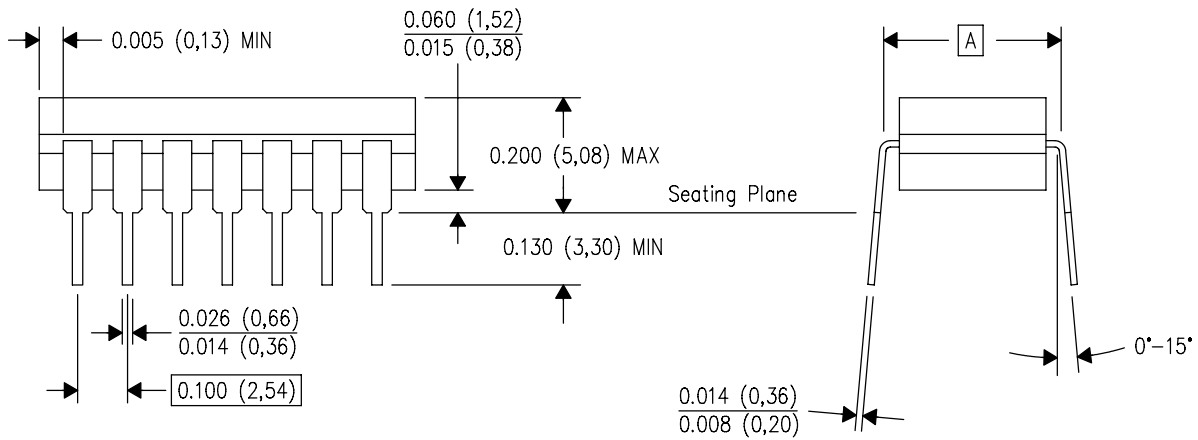

4040083/F 03/03

- NOTES:
- A. All linear dimensions are in inches (millimeters).
  - B. This drawing is subject to change without notice.
  - C. This package is hermetically sealed with a ceramic lid using glass frit.
  - D. Index point is provided on cap for terminal identification only on press ceramic glass frit seal only.
  - E. Falls within MIL STD 1835 GDIP1-T14, GDIP1-T16, GDIP1-T18 and GDIP1-T20.

# MECHANICAL DATA

W (R-GDFP-F14)

CERAMIC DUAL FLATPACK

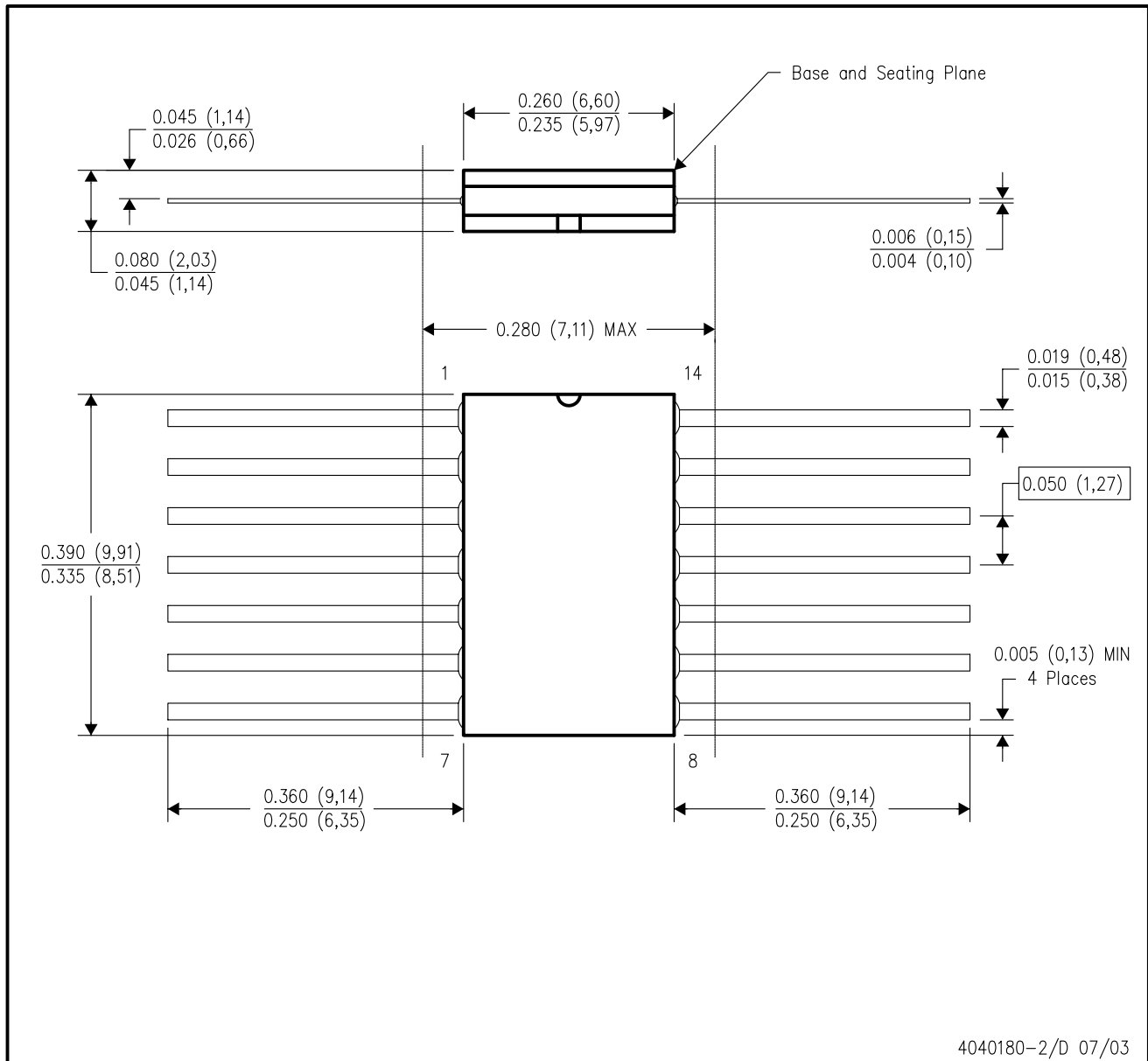

- NOTES:
- A. All linear dimensions are in inches (millimeters).
  - B. This drawing is subject to change without notice.
  - C. This package can be hermetically sealed with a ceramic lid using glass frit.
  - D. Index point is provided on cap for terminal identification only.
  - E. Falls within MIL STD 1835 GDFP1-F14 and JEDEC MO-092AB

# MECHANICAL DATA

MLCC006B – OCTOBER 1996

## FK (S-CQCC-N\*\*)

## LEADLESS CERAMIC CHIP CARRIER

28 TERMINAL SHOWN

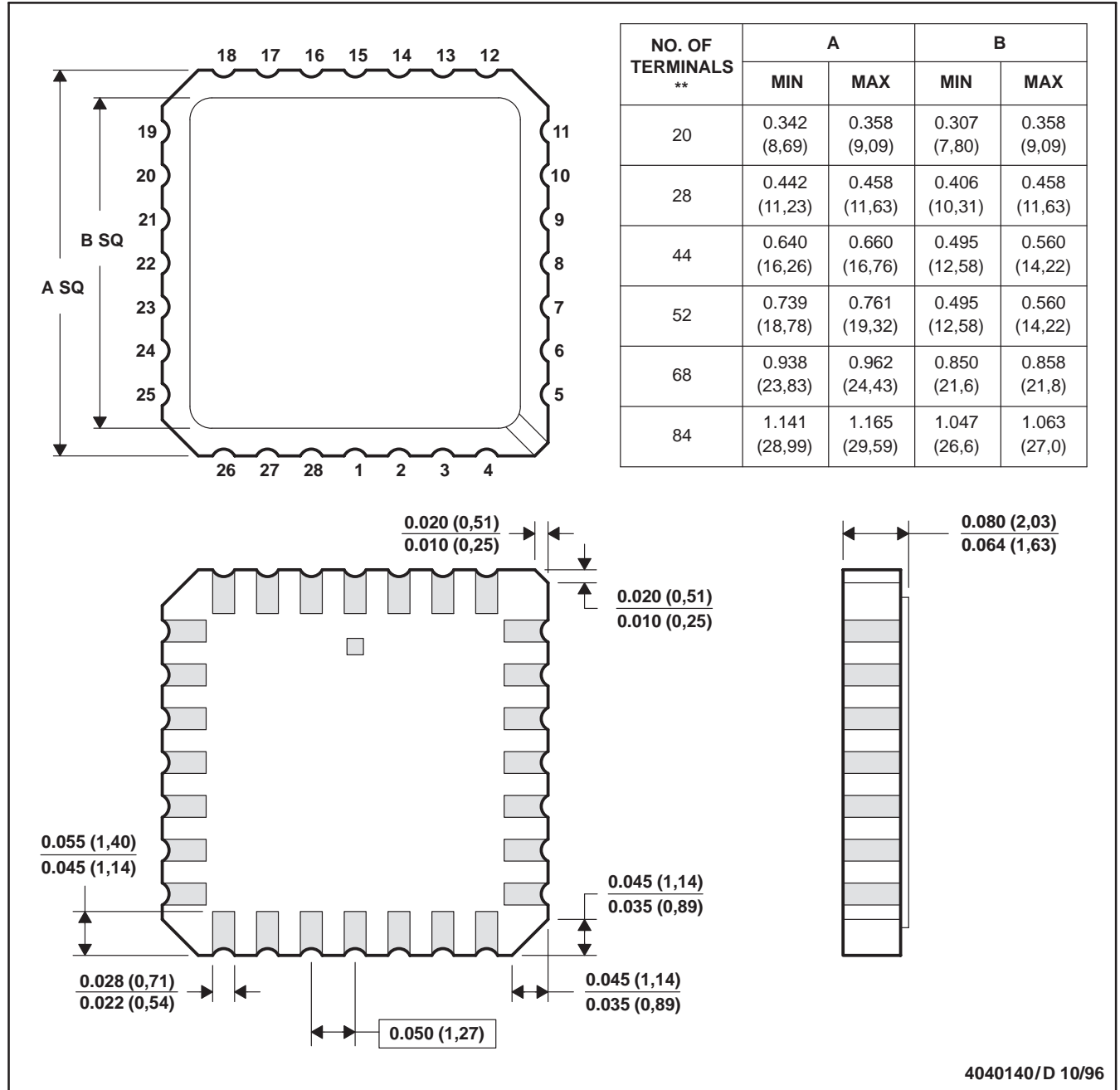

- NOTES:
- All linear dimensions are in inches (millimeters).
  - This drawing is subject to change without notice.
  - This package can be hermetically sealed with a metal lid.
  - The terminals are gold plated.
  - Falls within JEDEC MS-004

4040140/D 10/96

# MECHANICAL DATA

## N (R-PDIP-T\*\*)

## PLASTIC DUAL-IN-LINE PACKAGE

16 PINS SHOWN

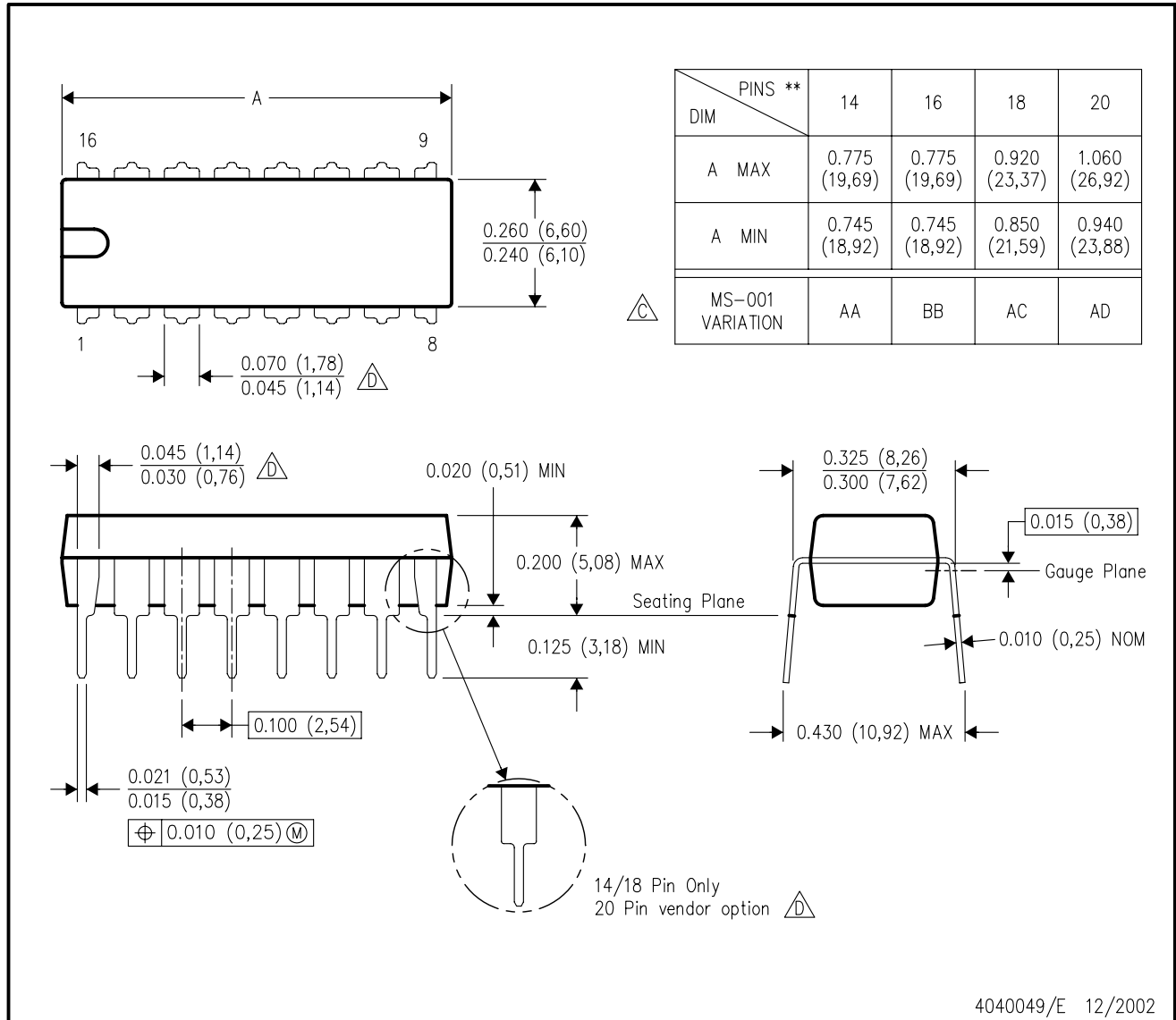

- NOTES:
- A. All linear dimensions are in inches (millimeters).
  - B. This drawing is subject to change without notice.
  - Falls within JEDEC MS-001, except 18 and 20 pin minimum body length (Dim A).
  - The 20 pin end lead shoulder width is a vendor option, either half or full width.

MECHANICAL DATA

D (R-PDSO-G14)

PLASTIC SMALL-OUTLINE PACKAGE

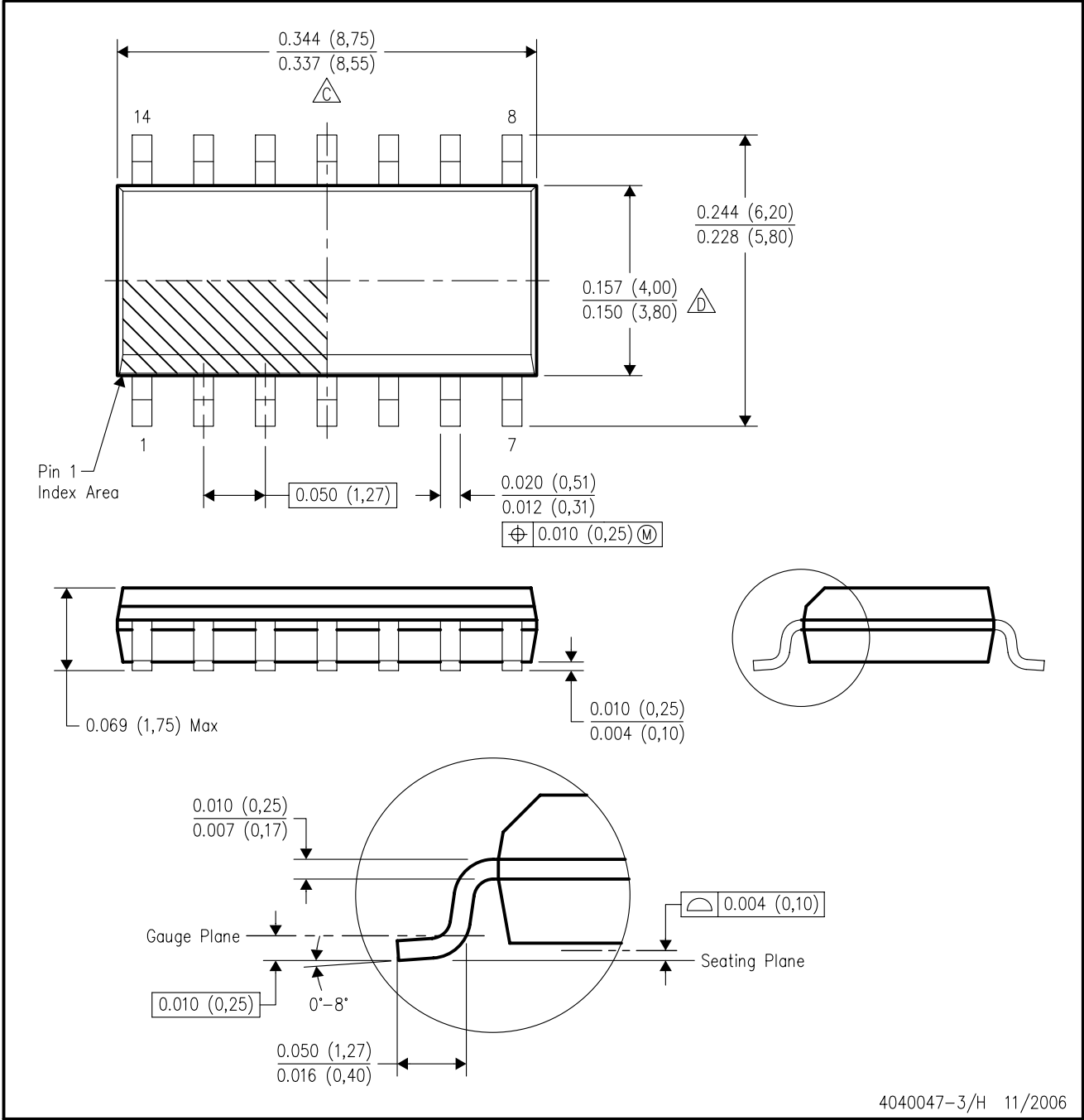

4040047-3/H 11/2006

- NOTES:
- A. All linear dimensions are in inches (millimeters).
  - B. This drawing is subject to change without notice.
  - C. Body length does not include mold flash, protrusions, or gate burrs. Mold flash, protrusions, or gate burrs shall not exceed .006 (0,15) per end.
  - D. Body width does not include interlead flash. Interlead flash shall not exceed .017 (0,43) per side.
  - E. Reference JEDEC MS-012 variation AB.

## MECHANICAL DATA

**NS (R-PDSO-G\*\*)**

**PLASTIC SMALL-OUTLINE PACKAGE**

**14-PINS SHOWN**

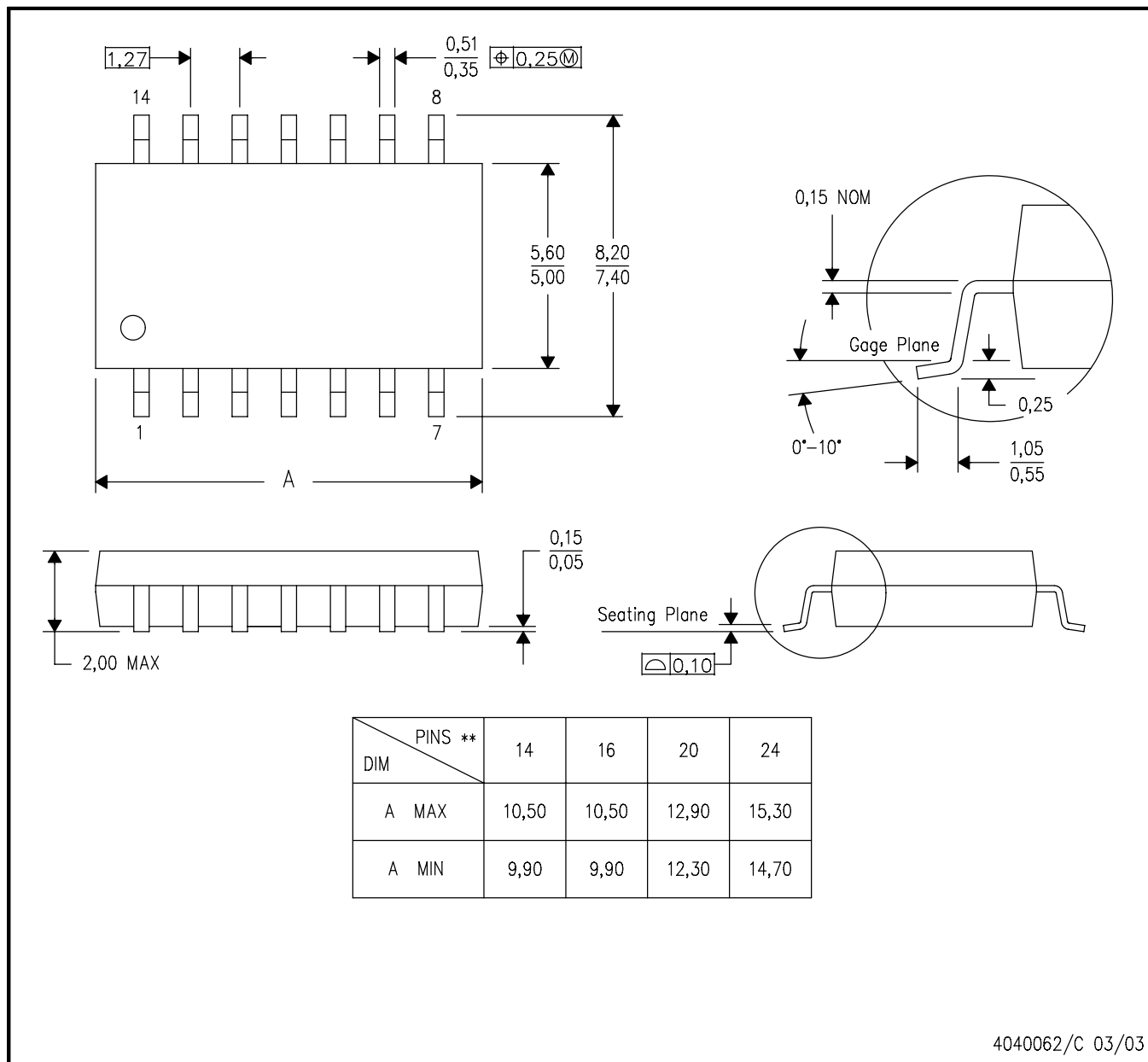

4040062/C 03/03

- NOTES:
- A. All linear dimensions are in millimeters.
  - B. This drawing is subject to change without notice.
  - C. Body dimensions do not include mold flash or protrusion, not to exceed 0,15.



# MECHANICAL DATA

MSS0002E – JANUARY 1995 – REVISED DECEMBER 2001

## DB (R-PDSO-G\*\*)

## PLASTIC SMALL-OUTLINE

28 PINS SHOWN

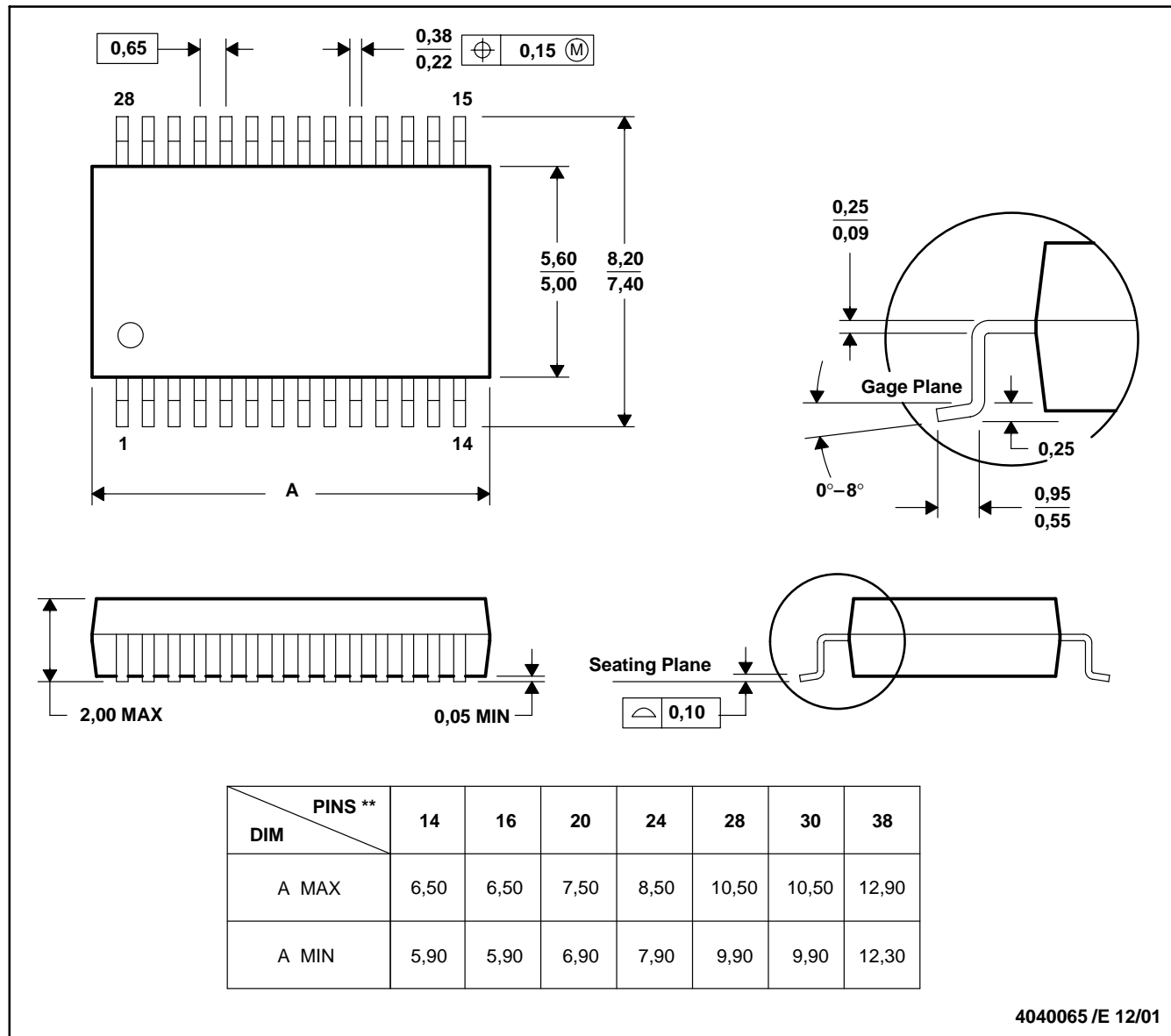

- NOTES:
- All linear dimensions are in millimeters.
  - This drawing is subject to change without notice.
  - Body dimensions do not include mold flash or protrusion not to exceed 0,15.
  - Falls within JEDEC MO-150

## IMPORTANT NOTICE

Texas Instruments Incorporated and its subsidiaries (TI) reserve the right to make corrections, modifications, enhancements, improvements, and other changes to its products and services at any time and to discontinue any product or service without notice. Customers should obtain the latest relevant information before placing orders and should verify that such information is current and complete. All products are sold subject to TI's terms and conditions of sale supplied at the time of order acknowledgment.

TI warrants performance of its hardware products to the specifications applicable at the time of sale in accordance with TI's standard warranty. Testing and other quality control techniques are used to the extent TI deems necessary to support this warranty. Except where mandated by government requirements, testing of all parameters of each product is not necessarily performed.

TI assumes no liability for applications assistance or customer product design. Customers are responsible for their products and applications using TI components. To minimize the risks associated with customer products and applications, customers should provide adequate design and operating safeguards.

TI does not warrant or represent that any license, either express or implied, is granted under any TI patent right, copyright, mask work right, or other TI intellectual property right relating to any combination, machine, or process in which TI products or services are used. Information published by TI regarding third-party products or services does not constitute a license from TI to use such products or services or a warranty or endorsement thereof. Use of such information may require a license from a third party under the patents or other intellectual property of the third party, or a license from TI under the patents or other intellectual property of TI.

Reproduction of information in TI data books or data sheets is permissible only if reproduction is without alteration and is accompanied by all associated warranties, conditions, limitations, and notices. Reproduction of this information with alteration is an unfair and deceptive business practice. TI is not responsible or liable for such altered documentation.

Resale of TI products or services with statements different from or beyond the parameters stated by TI for that product or service voids all express and any implied warranties for the associated TI product or service and is an unfair and deceptive business practice. TI is not responsible or liable for any such statements.

Following are URLs where you can obtain information on other Texas Instruments products and application solutions:

<b>Products</b>		<b>Applications</b>	
Amplifiers	<a href="http://amplifier.ti.com">amplifier.ti.com</a>	Audio	<a href="http://www.ti.com/audio">www.ti.com/audio</a>
Data Converters	<a href="http://dataconverter.ti.com">dataconverter.ti.com</a>	Automotive	<a href="http://www.ti.com/automotive">www.ti.com/automotive</a>
DSP	<a href="http://dsp.ti.com">dsp.ti.com</a>	Broadband	<a href="http://www.ti.com/broadband">www.ti.com/broadband</a>
Interface	<a href="http://interface.ti.com">interface.ti.com</a>	Digital Control	<a href="http://www.ti.com/digitalcontrol">www.ti.com/digitalcontrol</a>
Logic	<a href="http://logic.ti.com">logic.ti.com</a>	Military	<a href="http://www.ti.com/military">www.ti.com/military</a>
Power Mgmt	<a href="http://power.ti.com">power.ti.com</a>	Optical Networking	<a href="http://www.ti.com/opticalnetwork">www.ti.com/opticalnetwork</a>
Microcontrollers	<a href="http://microcontroller.ti.com">microcontroller.ti.com</a>	Security	<a href="http://www.ti.com/security">www.ti.com/security</a>
Low Power Wireless	<a href="http://www.ti.com/lpw">www.ti.com/lpw</a>	Telephony	<a href="http://www.ti.com/telephony">www.ti.com/telephony</a>
		Video & Imaging	<a href="http://www.ti.com/video">www.ti.com/video</a>
		Wireless	<a href="http://www.ti.com/wireless">www.ti.com/wireless</a>

Mailing Address: Texas Instruments  
Post Office Box 655303 Dallas, Texas 75265