

**SN55461 THRU SN55463  
SN75461 THRU SN75463  
DUAL PERIPHERAL DRIVERS**

SLRS022A – DECEMBER 1976 – REVISED OCTOBER 1995

**PERIPHERAL DRIVERS FOR  
HIGH-VOLTAGE, HIGH-CURRENT DRIVER  
APPLICATIONS**

- Characterized for Use to 300 mA
- High-Voltage Outputs
- No Output Latch-Up at 30 V (After Conducting 300 mA)
- Medium-Speed Switching
- Circuit Flexibility for Varied Applications and Choice of Logic Function
- TTL-Compatible Diode-Clamped Inputs
- Standard Supply Voltages
- Plastic DIP (P) With Copper Lead Frame for Cooler Operation and Improved Reliability
- Package Options Include Plastic Small Outline Packages, Ceramic Chip Carriers, and Standard Plastic and Ceramic 300-mil DIPs

SN55461, SN55462, SN55463 . . . JG PACKAGE  
SN75461, SN75462, SN75463 . . . D OR P PACKAGE  
(TOP VIEW)

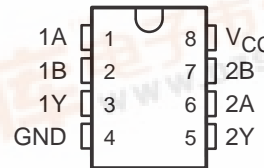

SN55461, SN55462, SN55463 . . . FK PACKAGE  
(TOP VIEW)

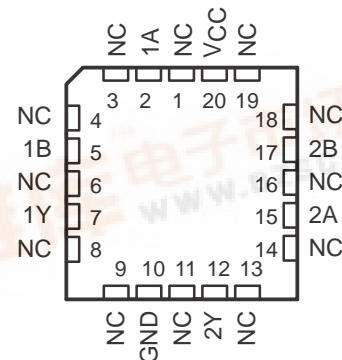

NC – No internal connection

SUMMARY OF SERIES 55461/75461

DEVICE	LOGIC	PACKAGES
SN55461	AND	FK, JG
SN55462	NAND	FK, JG
SN55463	OR	FK, JG
SN75461	AND	D, P
SN75462	NAND	D, P
SN75463	OR	D, P

**description**

These dual peripheral drivers are functionally interchangeable with SN55451B through SN55453B and SN75451B through SN75453B peripheral drivers, but are designed for use in systems that require higher breakdown voltages than those devices can provide at the expense of slightly slower switching speeds. Typical applications include logic buffers, power drivers, relay drivers, lamp drivers, MOS drivers, line drivers, and memory drivers.

The SN55461/SN75461, SN55462/SN75462, and SN55463/SN75463 are dual peripheral AND, NAND, and OR drivers respectively (assuming positive logic), with the output of the gates internally connected to the bases of the npn output transistors.

Series SN55461 drivers are characterized for operation over the full military temperature range of  $-55^{\circ}\text{C}$  to  $125^{\circ}\text{C}$ . Series SN75461 drivers are characterized for operation from  $0^{\circ}\text{C}$  to  $70^{\circ}\text{C}$ .



**SN55461 THRU SN55463**  
**SN75461 THRU SN75463**  
**DUAL PERIPHERAL DRIVERS**

SLRS022A – DECEMBER 1976 – REVISED OCTOBER 1995

**absolute maximum ratings over operating free-air temperature range (unless otherwise noted)†**

	SN55'	SN75'	UNIT
Supply voltage, $V_{CC}$ (see Note 1)	7	7	V
Input voltage, $V_I$	5.5	5.5	V
Intermitter voltage (see Note 2)	5.5	5.5	V
Off-state output voltage, $V_O$	35	35	V
Continuous collector or output current (see Note 3)	400	400	mA
Peak collector or output current ( $t_W \leq 10$ ms, duty cycle $\leq 50\%$ , see Note 4)	500	500	mA
Continuous total power dissipation	See Dissipation Rating Table		
Operating free-air temperature range, $T_A$	-55 to 125	0 to 70	°C
Storage temperature range, $T_{STG}$	-65 to 150	-65 to 150	°C
Case temperature for 60 seconds, $T_C$	FK package	260	°C
Lead temperature 1,6 mm (1/16 inch) from case for 60 seconds	JG package	300	°C
Lead temperature 1,6 mm (1/16 inch) from case for 10 seconds	D or P package	260	°C

† Stresses beyond those listed under "absolute maximum ratings" may cause permanent damage to the device. These are stress ratings only, and functional operation of the device at these or any other conditions beyond those indicated under "recommended operating conditions" is not implied. Exposure to absolute-maximum-rated conditions for extended periods may affect device reliability.

- NOTES:
1. Voltage values are with respect to network GND unless otherwise specified.
  2. This is the voltage between two emitters A and B.
  3. This value applies when the base-emitter resistance ( $R_{BE}$ ) is equal to or less than 500  $\Omega$ .
  4. Both halves of these dual circuits may conduct rated current simultaneously; however, power dissipation averaged over a short time interval must fall within the continuous dissipation rating.

**DISSIPATION RATING TABLE**

PACKAGE	$T_A \leq 25^\circ\text{C}$	DERATING FACTOR	$T_A = 70^\circ\text{C}$	$T_A = 125^\circ\text{C}$
	POWER RATING	ABOVE $T_A = 25^\circ\text{C}$	POWER RATING	POWER RATING
D	725 mW	5.8 mW/°C	464 mW	–
FK	1375 mW	11.0 mW/°C	880 mW	275 mW
JG	1050 mW	8.4 mW/°C	672 mW	210 mW
P	1000 mW	8.0 mW/°C	640 mW	–

**recommended operating conditions**

	SN55'			SN75'			UNIT
	MIN	NOM	MAX	MIN	NOM	MAX	
Supply voltage, $V_{CC}$	4.5	5	5.5	4.75	5	5.25	V
High-level input voltage, $V_{IH}$	2			2			V
Low-level input voltage, $V_{IL}$	0.8			0.8			V
Operating free-air temperature, $T_A$	-55			125			°C

# SN55461 THRU SN55463 SN75461 THRU SN75463 DUAL PERIPHERAL DRIVERS

SLRS022A – DECEMBER 1976 – REVISED OCTOBER 1995

## logic symbol†



† This symbol is in accordance with ANSI/IEEE Std 91-1984 and IEC Publication 617-12. Pin numbers shown are for D, JG, and P packages.

## logic diagram (positive logic)

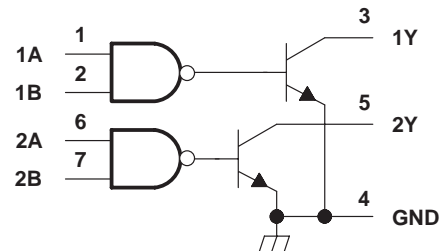

FUNCTION TABLE  
(each driver)

A	B	Y
L	L	L (on state)
L	H	L (on state)
H	L	L (on state)
H	H	H (off state)

positive logic:  
 $Y = AB \text{ or } \overline{A + B}$

## schematic (each driver)

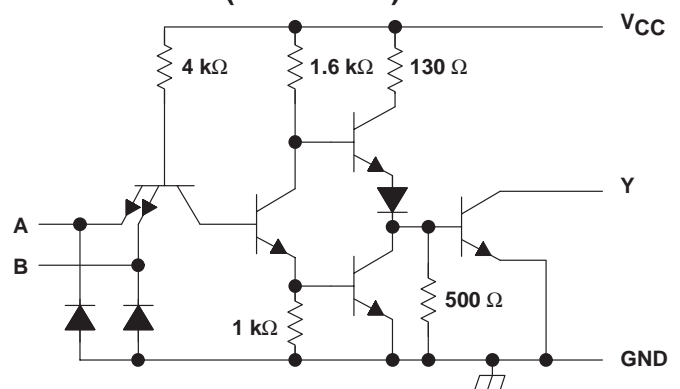

Resistor values shown are nominal.

## electrical characteristics over recommended operating free-air temperature range

PARAMETER	TEST CONDITIONS†	SN55461		SN75461		UNIT		
		MIN	TYP‡	MAX	MIN		TYP‡	MAX
$V_{IK}$ Input clamp voltage	$V_{CC} = \text{MIN}$ , $I_I = -12 \text{ mA}$	-1.2		-1.5	-1.2		-1.5	V
$I_{OH}$ High-level output current	$V_{CC} = \text{MIN}$ , $V_{IH} = \text{MIN}$ , $V_{OH} = 35 \text{ V}$			300			100	$\mu\text{A}$
$V_{OL}$ Low-level output voltage	$V_{CC} = \text{MIN}$ , $V_{IL} = 0.8 \text{ V}$ , $I_{OL} = 100 \text{ mA}$	0.25		0.5	0.25		0.4	V
	$V_{CC} = \text{MIN}$ , $V_{IL} = 0.8 \text{ V}$ , $I_{OL} = 300 \text{ mA}$	0.5		0.8	0.5		0.7	
$I_I$ Input current at maximum input voltage	$V_{CC} = \text{MAX}$ , $V_I = 5.5 \text{ V}$			1			1	mA
$I_{IH}$ High-level input current	$V_{CC} = \text{MAX}$ , $V_I = 2.4 \text{ V}$			40			40	$\mu\text{A}$
$I_{IL}$ Low-level input current	$V_{CC} = \text{MAX}$ , $V_I = 0.4 \text{ V}$	-1		-1.6	-1		-1.6	mA
$I_{CCH}$ Supply current, outputs high	$V_{CC} = \text{MAX}$ , $V_I = 5 \text{ V}$	8		11	8		11	mA
$I_{CCL}$ Supply current, outputs low	$V_{CC} = \text{MAX}$ , $V_I = 0$	56		76	56		76	mA

† For conditions shown as MIN or MAX, use the appropriate value specified under recommended operating conditions.

‡ All typical values are at  $V_{CC} = 5 \text{ V}$ ,  $T_A = 25^\circ\text{C}$ .

## switching characteristics, $V_{CC} = 5 \text{ V}$ , $T_A = 25^\circ\text{C}$

PARAMETER	TEST CONDITIONS	MIN	TYP	MAX	UNIT
$t_{PLH}$ Propagation delay time, low-to-high-level output	$I_O \approx 200 \text{ mA}$ , $C_L = 15 \text{ pF}$ , $R_L = 50 \Omega$ , See Figure 1		30	55	ns
$t_{PHL}$ Propagation delay time, high-to-low-level output			25	40	
$t_{TLH}$ Transition time, low-to-high-level output			8	20	
$t_{THL}$ Transition time, high-to-low-level output			10	20	
$V_{OH}$ High-level output voltage after switching	SN55461	$V_S = 30 \text{ V}$ , See Figure 2	$I_O \approx 300 \text{ mA}$ ,	$V_S - 10$	mV
	SN75461			$V_S - 10$	

# SN55461 THRU SN55463 SN75461 THRU SN75463 DUAL PERIPHERAL DRIVERS

SLRS022A – DECEMBER 1976 – REVISED OCTOBER 1995

## logic symbol†

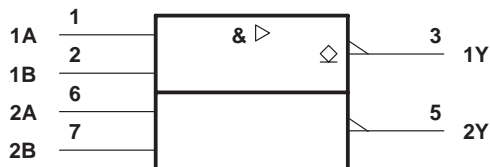

† This symbol is in accordance with ANSI/IEEE Std 91-1984 and IEC Publication 617-12.

Pin numbers shown are for D, JG, and P packages.

## logic diagram (positive logic)

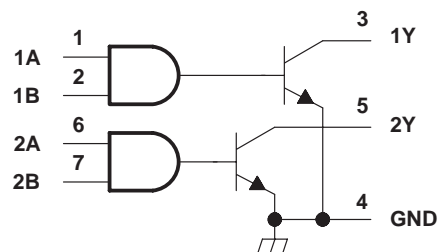

FUNCTION TABLE  
(each driver)

A	B	Y
L	L	H (off state)
L	H	H (off state)
H	L	H (off state)
H	H	L (on state)

positive logic:  
 $Y = AB \text{ or } \bar{A} + \bar{B}$

## schematic (each driver)

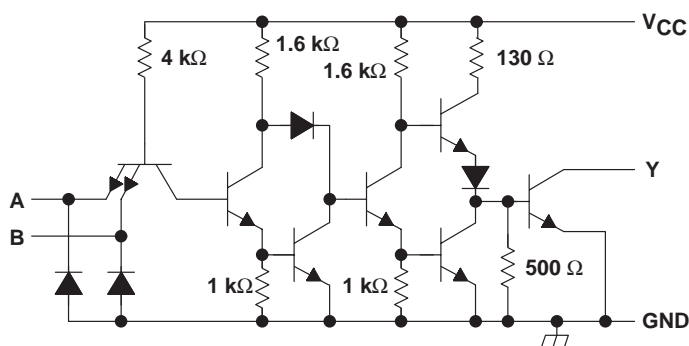

Resistor values shown are nominal.

## electrical characteristics over recommended operating free-air temperature range

PARAMETER	TEST CONDITIONS†	SN55462		SN75462		UNIT	
		MIN	TYP‡	MAX	MIN		TYP‡
$V_{IK}$ Input clamp voltage	$V_{CC} = \text{MIN}$ , $I_I = -12 \text{ mA}$	-1.2	-1.5	-1.2	-1.5	V	
$I_{OH}$ High-level output current	$V_{CC} = \text{MIN}$ , $V_{IL} = 0.8 \text{ V}$ , $V_{OH} = 35 \text{ V}$			300		100	$\mu\text{A}$
$V_{OL}$ Low-level output voltage	$V_{CC} = \text{MIN}$ , $V_{IH} = \text{MIN}$ , $I_{OL} = 100 \text{ mA}$	0.25	0.5	0.25	0.4	V	
	$V_{CC} = \text{MIN}$ , $V_{IH} = \text{MIN}$ , $I_{OL} = 300 \text{ mA}$	0.5	0.8	0.5	0.7		
$I_I$ Input current at maximum input voltage	$V_{CC} = \text{MAX}$ , $V_I = 5.5 \text{ V}$			1		1	mA
$I_{IH}$ High-level input current	$V_{CC} = \text{MAX}$ , $V_I = 2.4 \text{ V}$			40		40	$\mu\text{A}$
$I_{IL}$ Low-level input current	$V_{CC} = \text{MAX}$ , $V_I = 0.4 \text{ V}$	-1.1	-1.6	-1.1	-1.6		mA
$I_{CCH}$ Supply current, outputs high	$V_{CC} = \text{MAX}$ , $V_I = 0$	13	17	13	17		mA
$I_{CCL}$ Supply current, outputs low	$V_{CC} = \text{MAX}$ , $V_I = 5 \text{ V}$	61	76	61	76		mA

† For conditions shown as MIN or MAX, use the appropriate value specified under recommended operating conditions.

‡ All typical values are at  $V_{CC} = 5 \text{ V}$ ,  $T_A = 25^\circ\text{C}$ .

## switching characteristics, $V_{CC} = 5 \text{ V}$ , $T_A = 25^\circ\text{C}$

PARAMETER	TEST CONDITIONS	MIN	TYP	MAX	UNIT
$t_{PLH}$ Propagation delay time, low-to-high-level output	$I_O \approx 200 \text{ mA}$ , $C_L = 15 \text{ pF}$ , $R_L = 50 \Omega$ , See Figure 1		45	65	ns
$t_{PHL}$ Propagation delay time, high-to-low-level output			30	50	
$t_{TLH}$ Transition time, low-to-high-level output			13	25	
$t_{THL}$ Transition time, high-to-low-level output			10	20	
$V_{OH}$ High-level output voltage after switching	SN55462	$V_S - 10$		mV	
	SN75462	$V_S - 10$			

# SN55461 THRU SN55463 SN75461 THRU SN75463 DUAL PERIPHERAL DRIVERS

SLRS022A – DECEMBER 1976 – REVISED OCTOBER 1995

## logic symbol†



† This symbol is in accordance with ANSI/IEEE Std 91-1984 and IEC Publication 617-12.

Pin numbers shown are for D, JG, and P packages.

## logic diagram (positive logic)

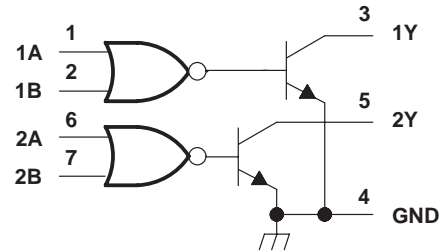

**FUNCTION TABLE**  
(each driver)

A	B	Y
L	L	L (on state)
L	H	H (off state)
H	L	H (off state)
H	H	H (off state)

positive logic:

$$Y = A + B \text{ or } \overline{A} \overline{B}$$

## schematic (each driver)

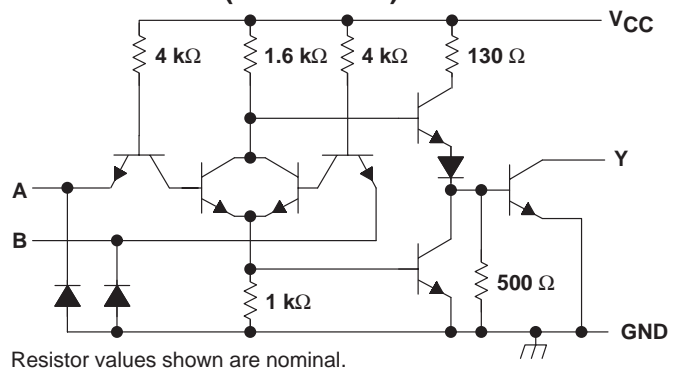

Resistor values shown are nominal.

## electrical characteristics over recommended operating free-air temperature range

PARAMETER	TEST CONDITIONS†	SN55463		SN75463		UNIT
		MIN	TYP‡	MAX	MIN	
$V_{IK}$ Input clamp voltage	$V_{CC} = \text{MIN}, I_I = -12 \text{ mA}$	-1.2	-1.5	-1.2	-1.5	V
$I_{OH}$ High-level output current	$V_{CC} = \text{MIN}, V_{IH} = \text{MIN}, V_{OH} = 35 \text{ V}$		300		100	$\mu\text{A}$
$V_{OL}$ Low-level output voltage	$V_{CC} = \text{MIN}, V_{IL} = 0.8 \text{ V}, I_{OL} = 100 \text{ mA}$	0.25	0.5	0.25	0.4	V
	$V_{CC} = \text{MIN}, V_{IL} = 0.8 \text{ V}, I_{OL} = 300 \text{ mA}$	0.5	0.8	0.5	0.7	
$I_I$ Input current at maximum input voltage	$V_{CC} = \text{MAX}, V_I = 5.5 \text{ V}$		1		1	mA
$I_{IH}$ High-level input current	$V_{CC} = \text{MAX}, V_I = 2.4 \text{ V}$		40		40	$\mu\text{A}$
$I_{IL}$ Low-level input current	$V_{CC} = \text{MAX}, V_I = 0.4 \text{ V}$	-1	-1.6	-1	-1.6	mA
$I_{CCH}$ Supply current, outputs high	$V_{CC} = \text{MAX}, V_I = 5 \text{ V}$	8	11	8	11	mA
$I_{CCL}$ Supply current, outputs low	$V_{CC} = \text{MAX}, V_I = 0$	58	76	58	76	mA

† For conditions shown as MIN or MAX, use the appropriate value specified under recommended operating conditions.

‡ All typical values are at  $V_{CC} = 5 \text{ V}, T_A = 25^\circ\text{C}$ .

## switching characteristics, $V_{CC} = 5 \text{ V}, T_A = 25^\circ\text{C}$

PARAMETER	TEST CONDITIONS	MIN	TYP	MAX	UNIT
$t_{PLH}$ Propagation delay time, low-to-high-level output	$I_O \approx 200 \text{ mA}, C_L = 15 \text{ pF}, R_L = 50 \Omega,$ See Figure 1		30	55	ns
$t_{PHL}$ Propagation delay time, high-to-low-level output			25	40	
$t_{TLH}$ Transition time, low-to-high-level output			8	25	
$t_{THL}$ Transition time, high-to-low-level output			10	25	
$V_{OH}$ High-level output voltage after switching	SN55463	$V_S - 10$		mV	
	SN75463	$V_S - 10$			

# SN55461 THRU SN55463 SN75461 THRU SN75463 DUAL PERIPHERAL DRIVERS

SLRS022A – DECEMBER 1976 – REVISED OCTOBER 1995

## PARAMETER MEASUREMENT INFORMATION

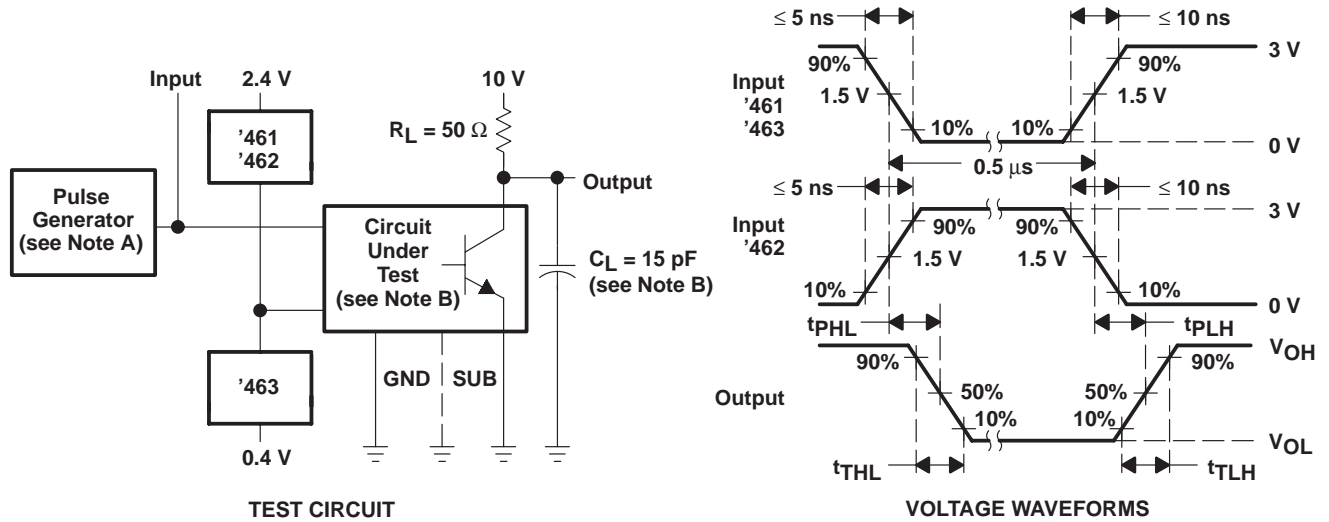

NOTES: A. The pulse generator has the following characteristics: PRR  $\leq$  1 MHz,  $Z_O \approx 50 \Omega$ .  
B.  $C_L$  includes probe and jig capacitance.

Figure 1. Test Circuit and Voltage Waveforms for Switching Times

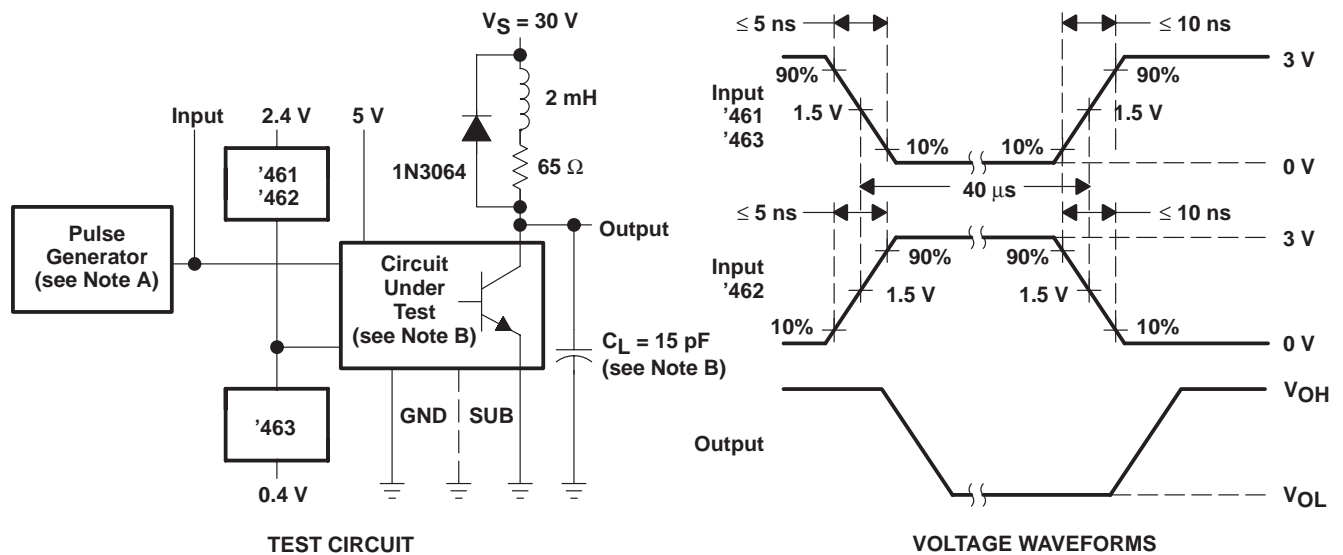

NOTES: A. The pulse generator has the following characteristics: PRR  $\leq$  12.5 kHz,  $Z_O = 50 \Omega$ .  
B.  $C_L$  includes probe and jig capacitance.

Figure 2. Test Circuit and Voltage Waveforms for Latch-Up Test

## PACKAGING INFORMATION

Orderable Device	Status <sup>(1)</sup>	Package Type	Package Drawing	Pins	Package Qty	Eco Plan <sup>(2)</sup>	Lead/Ball Finish	MSL Peak Temp <sup>(3)</sup>
JM38510/12908BPA	ACTIVE	CDIP	JG	8	1	TBD	A42 SNPB	Level-NC-NC-NC
JM38510/12909BPA	OBSOLETE	CDIP	JG	8		TBD	Call TI	Call TI
SN55461JG	OBSOLETE	CDIP	JG	8		TBD	Call TI	Call TI
SN55462JG	OBSOLETE	CDIP	JG	8		TBD	Call TI	Call TI
SN55463JG	OBSOLETE	CDIP	JG	8		TBD	Call TI	Call TI
SN75461D	OBSOLETE	SOIC	D	8		TBD	Call TI	Call TI
SN75461P	OBSOLETE	PDIP	P	8		TBD	Call TI	Call TI
SN75462D	ACTIVE	SOIC	D	8	75	Green (RoHS & no Sb/Br)	CU NIPDAU	Level-1-260C-UNLIM
SN75462DE4	ACTIVE	SOIC	D	8	75	Green (RoHS & no Sb/Br)	CU NIPDAU	Level-1-260C-UNLIM
SN75462DR	ACTIVE	SOIC	D	8	2500	Green (RoHS & no Sb/Br)	CU NIPDAU	Level-1-260C-UNLIM
SN75462DRE4	ACTIVE	SOIC	D	8	2500	Green (RoHS & no Sb/Br)	CU NIPDAU	Level-1-260C-UNLIM
SN75462P	ACTIVE	PDIP	P	8	50	Pb-Free (RoHS)	CU NIPDAU	Level-NC-NC-NC
SN75462PE4	ACTIVE	PDIP	P	8	50	Pb-Free (RoHS)	CU NIPDAU	Level-NC-NC-NC
SN75463D	OBSOLETE	SOIC	D	8		TBD	Call TI	Call TI
SN75463DR	OBSOLETE	SOIC	D	8		TBD	Call TI	Call TI
SN75463P	ACTIVE	PDIP	P	8	50	Pb-Free (RoHS)	CU NIPDAU	Level-NC-NC-NC
SN75463PE4	ACTIVE	PDIP	P	8	50	Pb-Free (RoHS)	CU NIPDAU	Level-NC-NC-NC
SNJ55461FK	OBSOLETE	LCCC	FK	20		TBD	Call TI	Call TI
SNJ55461JG	OBSOLETE	CDIP	JG	8		TBD	Call TI	Call TI
SNJ55462FK	ACTIVE	LCCC	FK	20	1	TBD	POST-PLATE	Level-NC-NC-NC
SNJ55462JG	ACTIVE	CDIP	JG	8	1	TBD	A42 SNPB	Level-NC-NC-NC
SNJ55463JG	OBSOLETE	CDIP	JG	8		TBD	Call TI	Call TI

<sup>(1)</sup> The marketing status values are defined as follows:

**ACTIVE:** Product device recommended for new designs.

**LIFEBUY:** TI has announced that the device will be discontinued, and a lifetime-buy period is in effect.

**NRND:** Not recommended for new designs. Device is in production to support existing customers, but TI does not recommend using this part in a new design.

**PREVIEW:** Device has been announced but is not in production. Samples may or may not be available.

**OBSOLETE:** TI has discontinued the production of the device.

<sup>(2)</sup> Eco Plan - The planned eco-friendly classification: Pb-Free (RoHS) or Green (RoHS & no Sb/Br) - please check <http://www.ti.com/productcontent> for the latest availability information and additional product content details.

**TBD:** The Pb-Free/Green conversion plan has not been defined.

**Pb-Free (RoHS):** TI's terms "Lead-Free" or "Pb-Free" mean semiconductor products that are compatible with the current RoHS requirements for all 6 substances, including the requirement that lead not exceed 0.1% by weight in homogeneous materials. Where designed to be soldered at high temperatures, TI Pb-Free products are suitable for use in specified lead-free processes.

**Green (RoHS & no Sb/Br):** TI defines "Green" to mean Pb-Free (RoHS compatible), and free of Bromine (Br) and Antimony (Sb) based flame retardants (Br or Sb do not exceed 0.1% by weight in homogeneous material)

<sup>(3)</sup> MSL, Peak Temp. -- The Moisture Sensitivity Level rating according to the JEDEC industry standard classifications, and peak solder temperature.

**Important Information and Disclaimer:**The information provided on this page represents TI's knowledge and belief as of the date that it is provided. TI bases its knowledge and belief on information provided by third parties, and makes no representation or warranty as to the accuracy of such information. Efforts are underway to better integrate information from third parties. TI has taken and continues to take reasonable steps to provide representative and accurate information but may not have conducted destructive testing or chemical analysis on incoming materials and chemicals. TI and TI suppliers consider certain information to be proprietary, and thus CAS numbers and other limited information may not be available for release.

In no event shall TI's liability arising out of such information exceed the total purchase price of the TI part(s) at issue in this document sold by TI to Customer on an annual basis.



# MECHANICAL DATA

MCER001A – JANUARY 1995 – REVISED JANUARY 1997

JG (R-GDIP-T8)

CERAMIC DUAL-IN-LINE

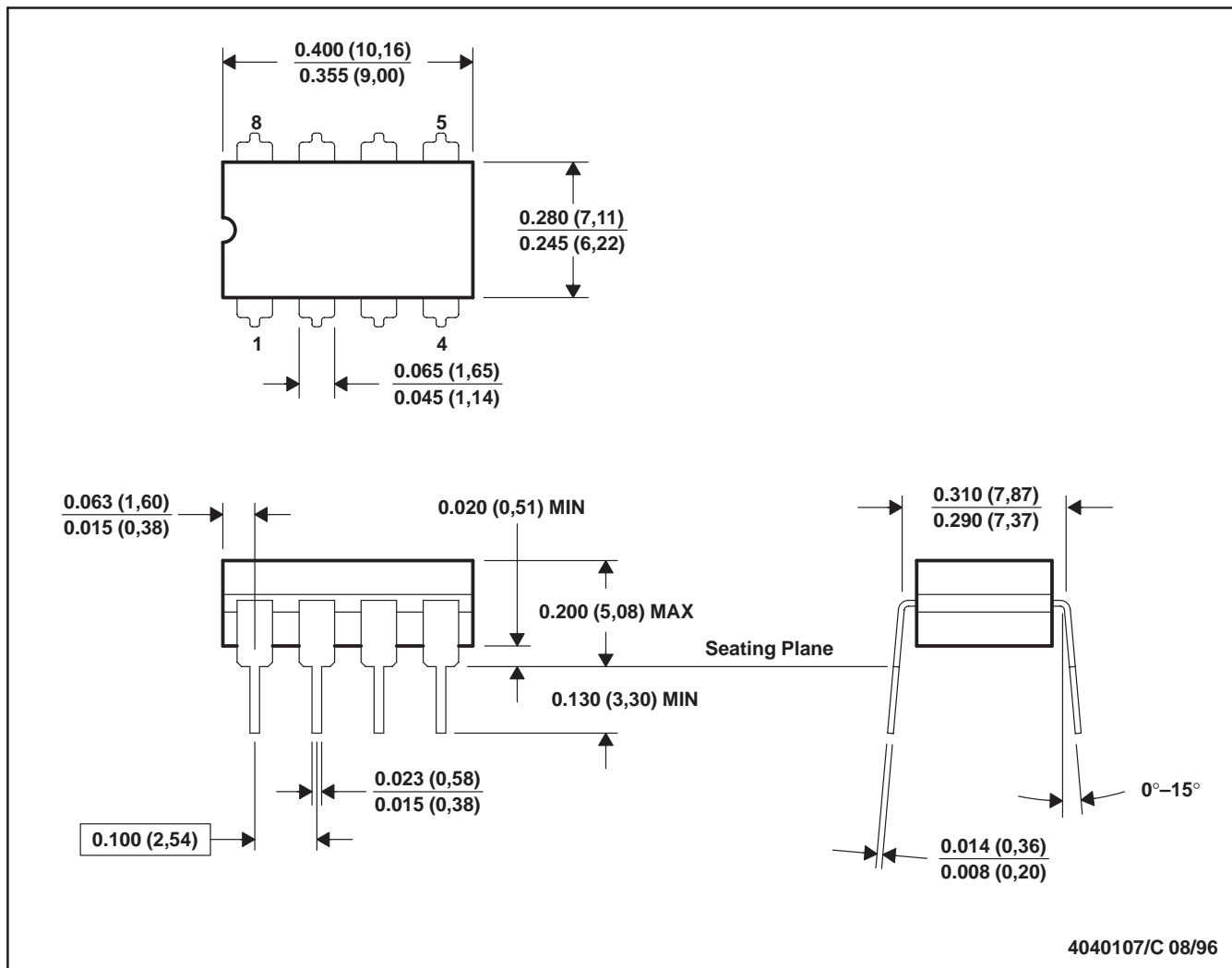

- NOTES:
- All linear dimensions are in inches (millimeters).
  - This drawing is subject to change without notice.
  - This package can be hermetically sealed with a ceramic lid using glass frit.
  - Index point is provided on cap for terminal identification.
  - Falls within MIL STD 1835 GDIP1-T8

# MECHANICAL DATA

MLCC006B – OCTOBER 1996

## FK (S-CQCC-N\*\*)

## LEADLESS CERAMIC CHIP CARRIER

28 TERMINAL SHOWN



- NOTES:
- All linear dimensions are in inches (millimeters).
  - This drawing is subject to change without notice.
  - This package can be hermetically sealed with a metal lid.
  - The terminals are gold plated.
  - Falls within JEDEC MS-004

4040140/D 10/96

# MECHANICAL DATA

MPDI001A – JANUARY 1995 – REVISED JUNE 1999

P (R-PDIP-T8)

PLASTIC DUAL-IN-LINE

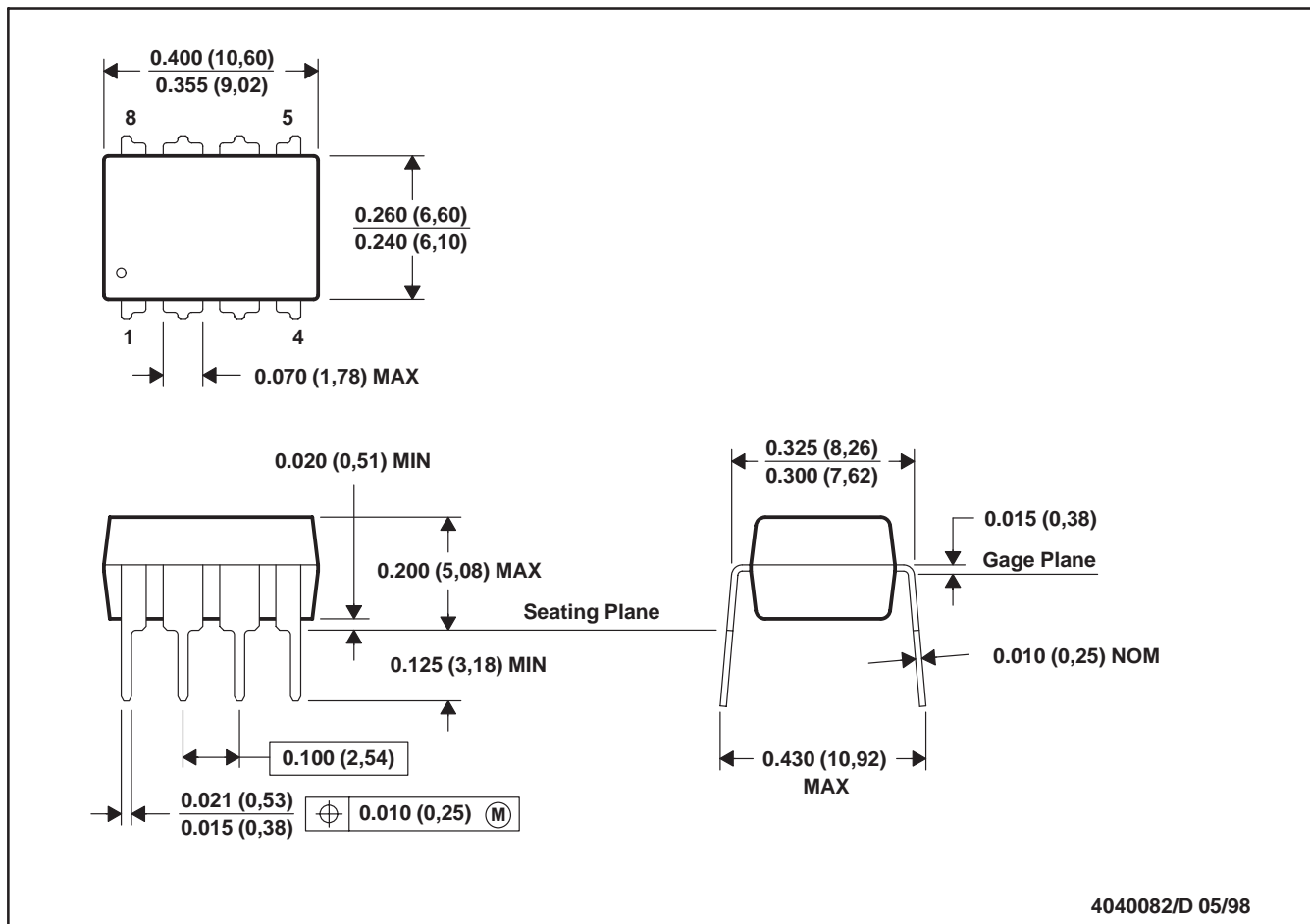

4040082/D 05/98

- NOTES: A. All linear dimensions are in inches (millimeters).  
 B. This drawing is subject to change without notice.  
 C. Falls within JEDEC MS-001

# MECHANICAL DATA

D (R-PDSO-G8)

PLASTIC SMALL-OUTLINE PACKAGE

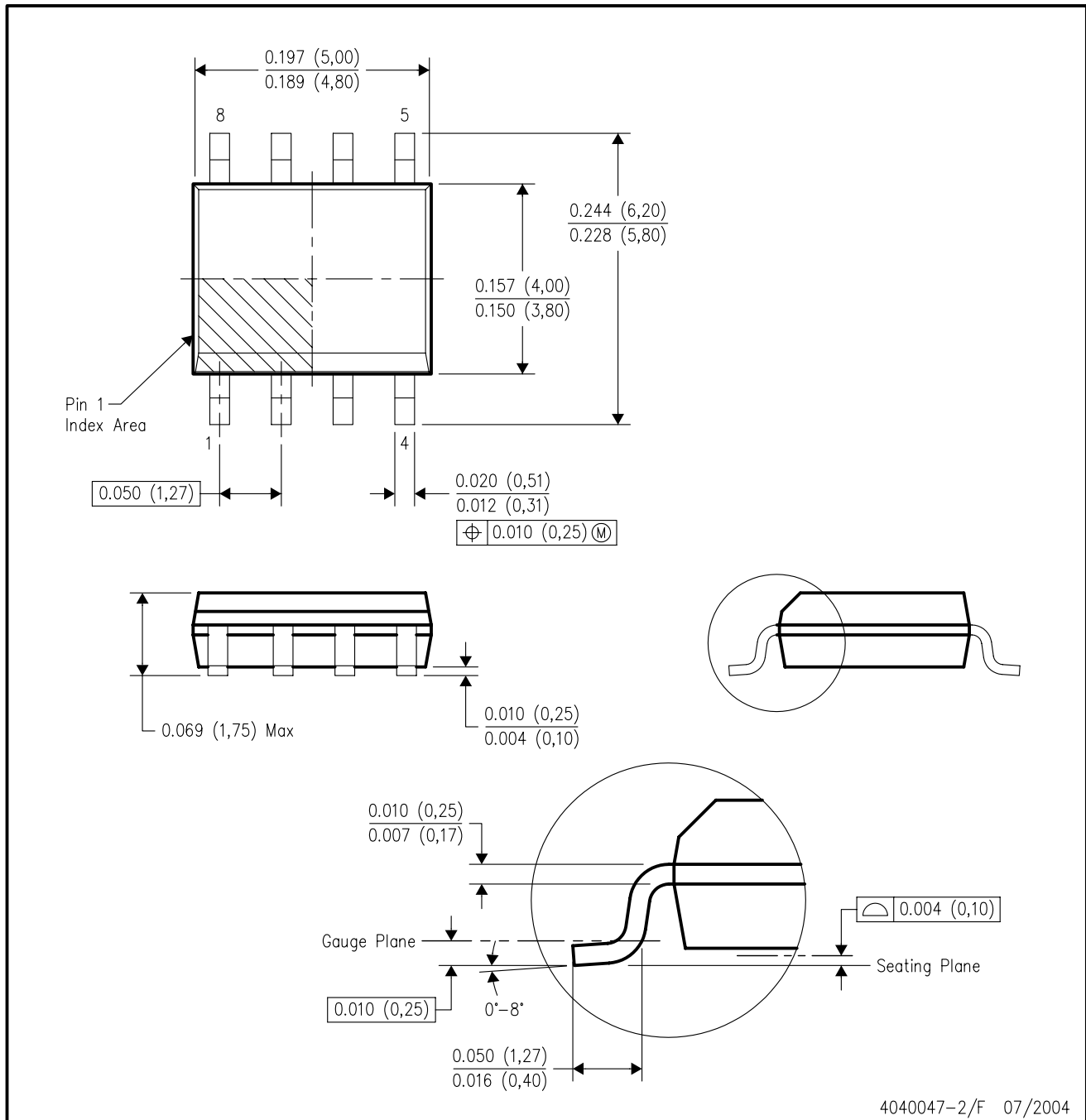

- NOTES:
- All linear dimensions are in inches (millimeters).
  - This drawing is subject to change without notice.
  - Body dimensions do not include mold flash or protrusion not to exceed 0.006 (0,15).
  - Falls within JEDEC MS-012 variation AA.

## IMPORTANT NOTICE

Texas Instruments Incorporated and its subsidiaries (TI) reserve the right to make corrections, modifications, enhancements, improvements, and other changes to its products and services at any time and to discontinue any product or service without notice. Customers should obtain the latest relevant information before placing orders and should verify that such information is current and complete. All products are sold subject to TI's terms and conditions of sale supplied at the time of order acknowledgment.

TI warrants performance of its hardware products to the specifications applicable at the time of sale in accordance with TI's standard warranty. Testing and other quality control techniques are used to the extent TI deems necessary to support this warranty. Except where mandated by government requirements, testing of all parameters of each product is not necessarily performed.

TI assumes no liability for applications assistance or customer product design. Customers are responsible for their products and applications using TI components. To minimize the risks associated with customer products and applications, customers should provide adequate design and operating safeguards.

TI does not warrant or represent that any license, either express or implied, is granted under any TI patent right, copyright, mask work right, or other TI intellectual property right relating to any combination, machine, or process in which TI products or services are used. Information published by TI regarding third-party products or services does not constitute a license from TI to use such products or services or a warranty or endorsement thereof. Use of such information may require a license from a third party under the patents or other intellectual property of the third party, or a license from TI under the patents or other intellectual property of TI.

Reproduction of information in TI data books or data sheets is permissible only if reproduction is without alteration and is accompanied by all associated warranties, conditions, limitations, and notices. Reproduction of this information with alteration is an unfair and deceptive business practice. TI is not responsible or liable for such altered documentation.

Resale of TI products or services with statements different from or beyond the parameters stated by TI for that product or service voids all express and any implied warranties for the associated TI product or service and is an unfair and deceptive business practice. TI is not responsible or liable for any such statements.

Following are URLs where you can obtain information on other Texas Instruments products and application solutions:

<b>Products</b>		<b>Applications</b>	
Amplifiers	<a href="http://amplifier.ti.com">amplifier.ti.com</a>	Audio	<a href="http://www.ti.com/audio">www.ti.com/audio</a>
Data Converters	<a href="http://dataconverter.ti.com">dataconverter.ti.com</a>	Automotive	<a href="http://www.ti.com/automotive">www.ti.com/automotive</a>
DSP	<a href="http://dsp.ti.com">dsp.ti.com</a>	Broadband	<a href="http://www.ti.com/broadband">www.ti.com/broadband</a>
Interface	<a href="http://interface.ti.com">interface.ti.com</a>	Digital Control	<a href="http://www.ti.com/digitalcontrol">www.ti.com/digitalcontrol</a>
Logic	<a href="http://logic.ti.com">logic.ti.com</a>	Military	<a href="http://www.ti.com/military">www.ti.com/military</a>
Power Mgmt	<a href="http://power.ti.com">power.ti.com</a>	Optical Networking	<a href="http://www.ti.com/opticalnetwork">www.ti.com/opticalnetwork</a>
Microcontrollers	<a href="http://microcontroller.ti.com">microcontroller.ti.com</a>	Security	<a href="http://www.ti.com/security">www.ti.com/security</a>
		Telephony	<a href="http://www.ti.com/telephony">www.ti.com/telephony</a>
		Video & Imaging	<a href="http://www.ti.com/video">www.ti.com/video</a>
		Wireless	<a href="http://www.ti.com/wireless">www.ti.com/wireless</a>

Mailing Address: Texas Instruments  
Post Office Box 655303 Dallas, Texas 75265