

KA2243

查询KA2243供应商

捷多部 专业PCB打样工厂 24小时加急出货

LINEAR INTEGRATED CIRCUIT

AM/FM IF SYSTEM

The KA2243 is a monolithic integrated circuit developed for radio cassette tape recorders which include AM/FM IF amplifier and detector.

FUNCTIONS

- AM Section:
 - IF amplifier with AGC detector.
 - Signal meter driver circuit.
 - Voltage regulator for RF external circuit.
- FM Section:
 - IF amplifier.
 - Quadrature detector.
 - Post amplifier.
 - Signal meter driver circuit.

FEATURES

- Suitable for radio cassettes and home stereos.
- **Wide operating supply voltage range:** $V_{CC} = 3V \sim 14V$.
- **Low quiescent circuit current.**
- **AM section.**
 - Simplified input circuit IFT (Ceramic filter type).
 - RF AGC available.
- **FM section.**
 - High limiting sensitivity ($33dB\mu$, Typ).
 - Low residual noise ($45dB$ at $V_i = -10dB\mu$).
 - Small side peak or detuned output voltage.

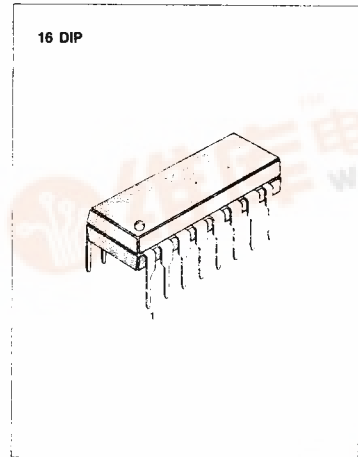

ORDERING INFORMATION

Device	Package	Operating Temperature
KA2243	16 DIP	-20°C ~ +70°C

BLOCK DIAGRAM

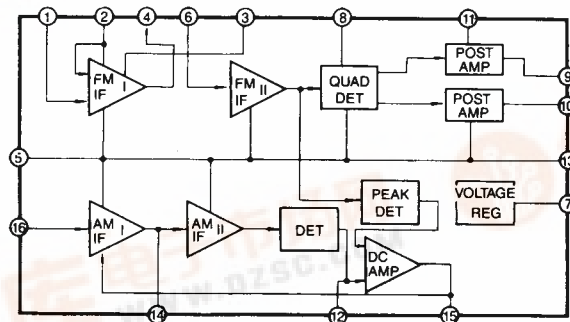

ABSOLUTE MAXIMUM RATINGS ($T_a = 25^\circ\text{C}$)

Characteristic	Symbol	Value	Unit
Supply Voltage	V_{CC}	16	V
Power Dissipation	P_D	600	mW
Operating Temperature	T_{OPR}	-20 ~ +70	$^\circ\text{C}$
Storage Temperature	T_{STG}	-40 ~ +125	$^\circ\text{C}$

ELECTRICAL CHARACTERISTICS

($T_a = 25^\circ\text{C}$, $V_{CC} = 5.5\text{V}$, unless otherwise specified)

Characteristic	Symbol	Test Conditions	Min	Typ	Max	Unit
----------------	--------	-----------------	-----	-----	-----	------

FM Section ($f = 10.7\text{MHz}$, $f_m = 1\text{KHz}$, $\Delta f = \pm 75\text{KHz}$)

Quiescent Circuit Current	I_{CCQ}	$V_i = 0$	7	11	16.5	mA
-3dB Limiting Sensitivity	$V_{i(LIM)}$	$V_o (V_i = 100\text{dB}\mu) - 3\text{dB}$		33	38	$\text{dB}\mu$
Detector Output Voltage	$V_{O(DET)}$	$V_i = 100\text{dB}\mu$	180	245	310	mV
Total Harmonic Distortion	THD	$V_i = 100\text{dB}\mu$		0.3	1.0	%
AM Rejection Ratio	AMR	$V_i = 100\text{dB}\mu$	50	60		dB
Signal to Noise Ratio	S/N	$V_i = 100\text{dB}\mu$	72	83		dB
Signal Meter Output	V_M	$V_i = 100\text{dB}\mu$	1.05	1.5	2.05	V
Residual Noise	V_N	$V_o (AF) (V_i = 100\text{dB}\mu)$ $V_o (AF) (V_i = -10\text{dB}\mu)$		45		dB
Muting Attenuation	ATT_{MUTE}	$V_i = 37\text{dB}\mu$, Mute SW on		35		dB

AM Section ($f = 455\text{KHz}$, $f_m = 1\text{KHz}$, 30% Mod)

Quiescent Circuit Current	I_{CCQ}	$V_i = 0$		8		mA
Maximum Sensitivity	S_{MAX}	$V_o (AF) = 10\text{mV}$		29		$\text{dB}\mu$
Detector Output Voltage	V_o	$V_i = 74\text{dB}\mu$	45	65	85	mV
Total Harmonic Distortion	THD	$V_i = 74\text{dB}\mu$		0.3	2.0	%
		$V_i = 100\text{dB}\mu$		0.7	3.5	%
Signal to Noise Ratio	S/N	$V_i = 74\text{dB}\mu$	45	55		$\text{dB}\mu$
Signal Meter Output	V_M	$V_i = 100\text{dB}\mu$	1.2	1.4	1.6	V
Input Impedance (Pin 16)	Z_i	Pin 16 0.8-0.9V _{DC}	1.45	2.12	2.8	K Ω

TEST CIRCUIT

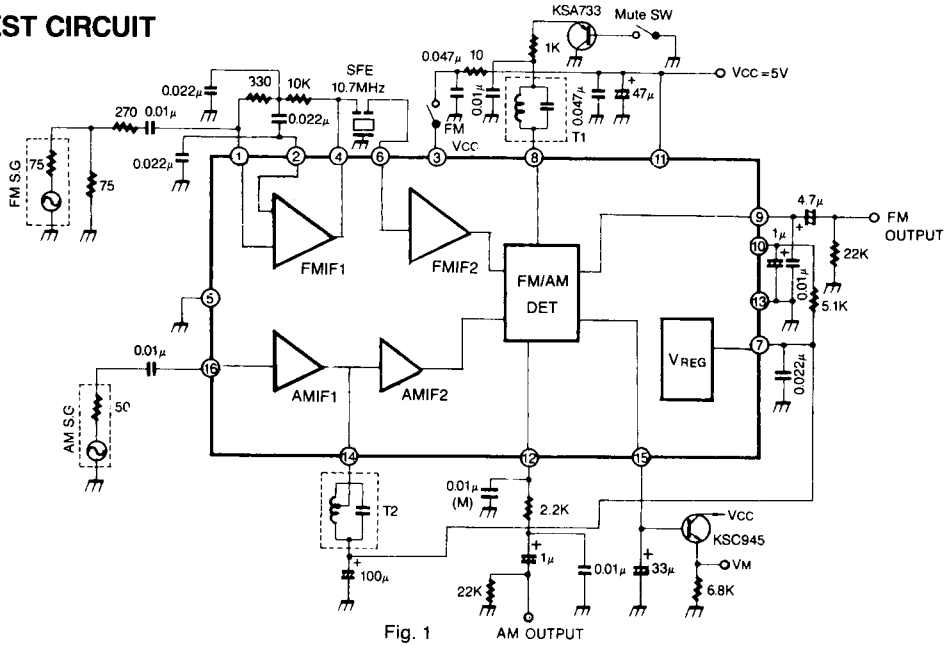
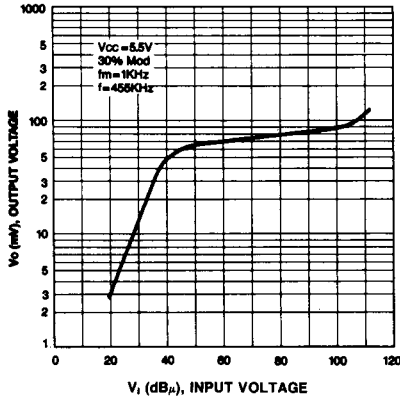

Fig. 1

(AM Section)

OUTPUT VOLTAGE-INPUT VOLTAGE



TOTAL HARMONIC DISTORTION-INPUT VOLTAGE

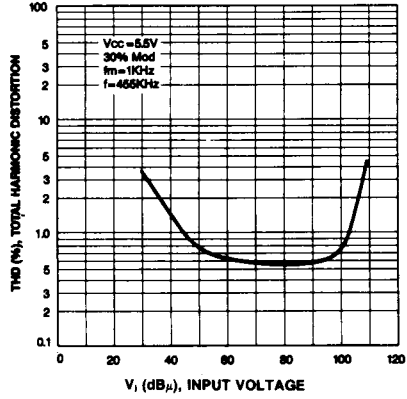

SIGNAL TO NOISE RATIO-INPUT VOLTAGE

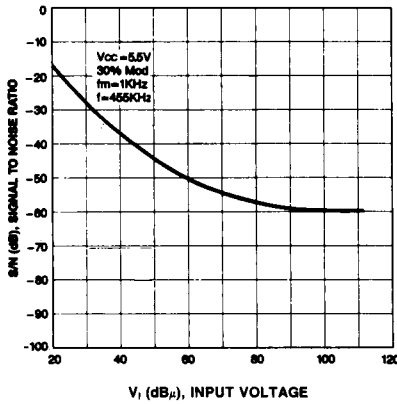

SIGNAL METER OUTPUT VOLTAGE-INPUT VOLTAGE

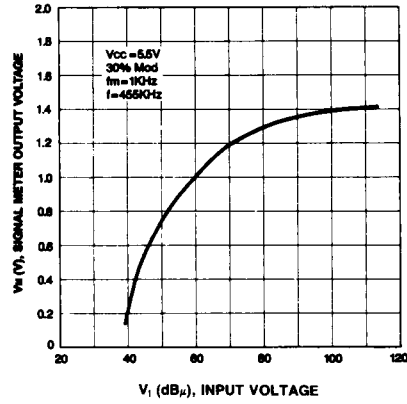

OUTPUT VOLTAGE-SUPPLY VOLTAGE

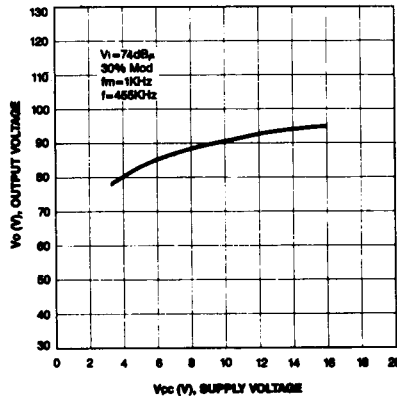

TOTAL HARMONIC DISTORTION-SUPPLY VOLTAGE

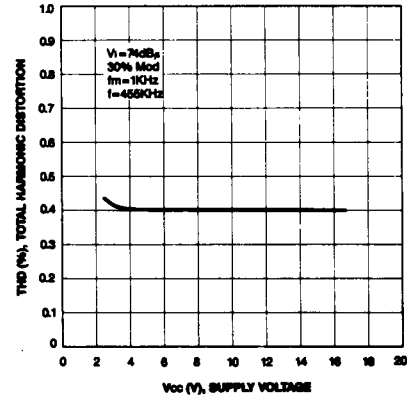

QUIESCENT CIRCUIT CURRENT-SUPPLY VOLTAGE

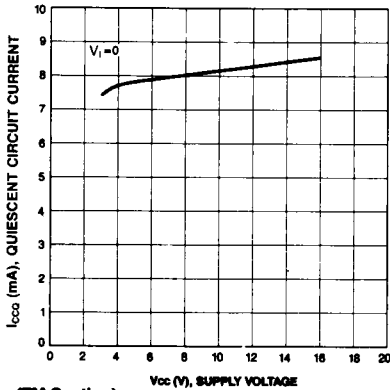

(FM Section)

OUTPUT VOLTAGE-INPUT VOLTAGE

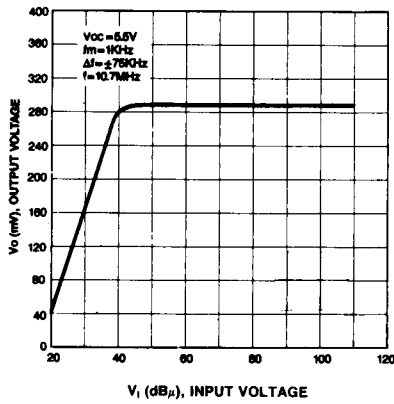

SIGNAL TO NOISE RATIO-INPUT VOLTAGE

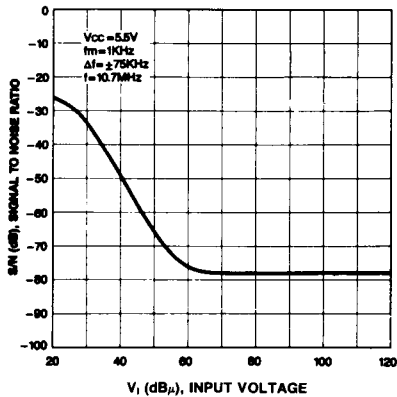

OUTPUT VOLTAGE — MODULATION
TOTAL HARMONIC DISTORTION

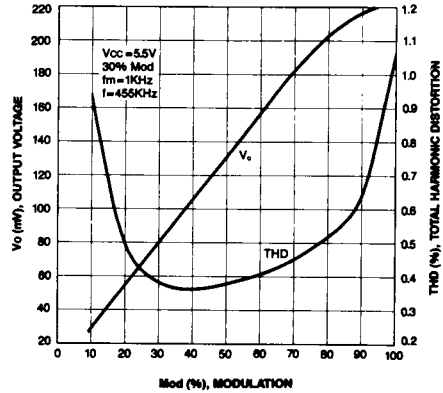

TOTAL HARMONIC DISTORTION-INPUT VOLTAGE

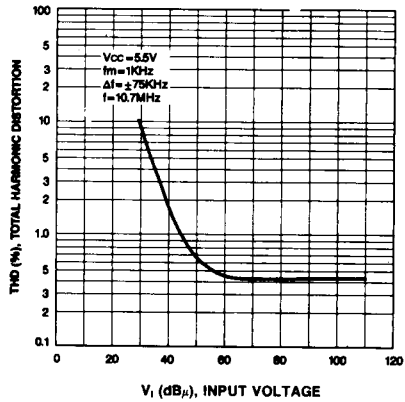

AM REJECTION RATIO-INPUT VOLTAGE

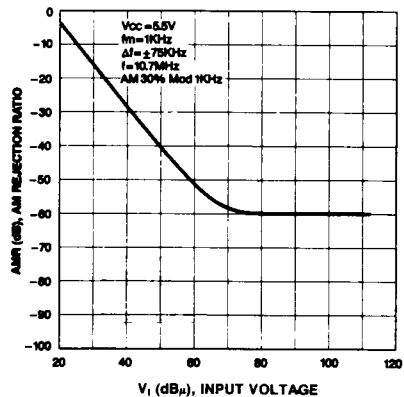

SIGNAL METER OUTPUT VOLTAGE-INPUT VOLTAGE

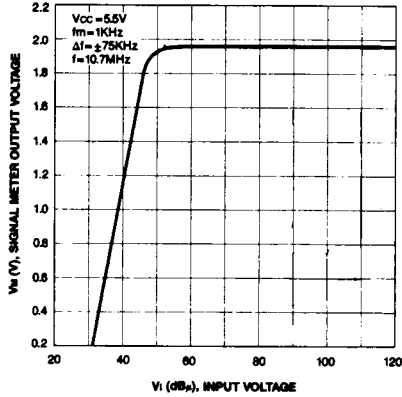

OUTPUT VOLTAGE-SUPPLY VOLTAGE

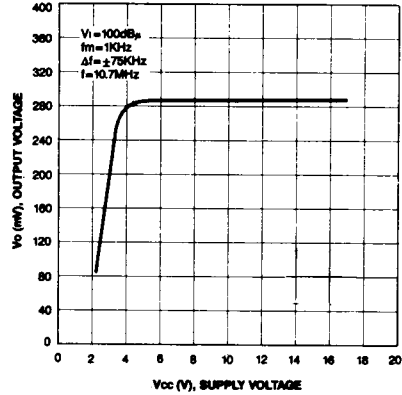

TOTAL HARMONIC DISTORTION-SUPPLY VOLTAGE

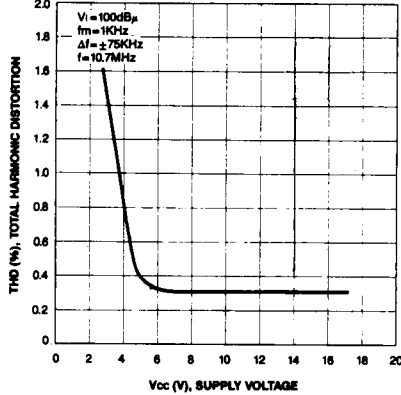

OUTPUT VOLTAGE-INPUT FREQUENCY

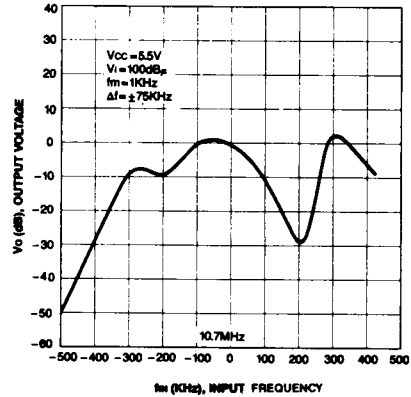

QUIESCENT CIRCUIT CURRENT-SUPPLY VOLTAGE

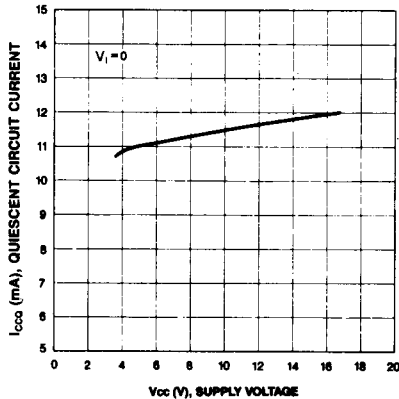

APPLICATION CIRCUIT

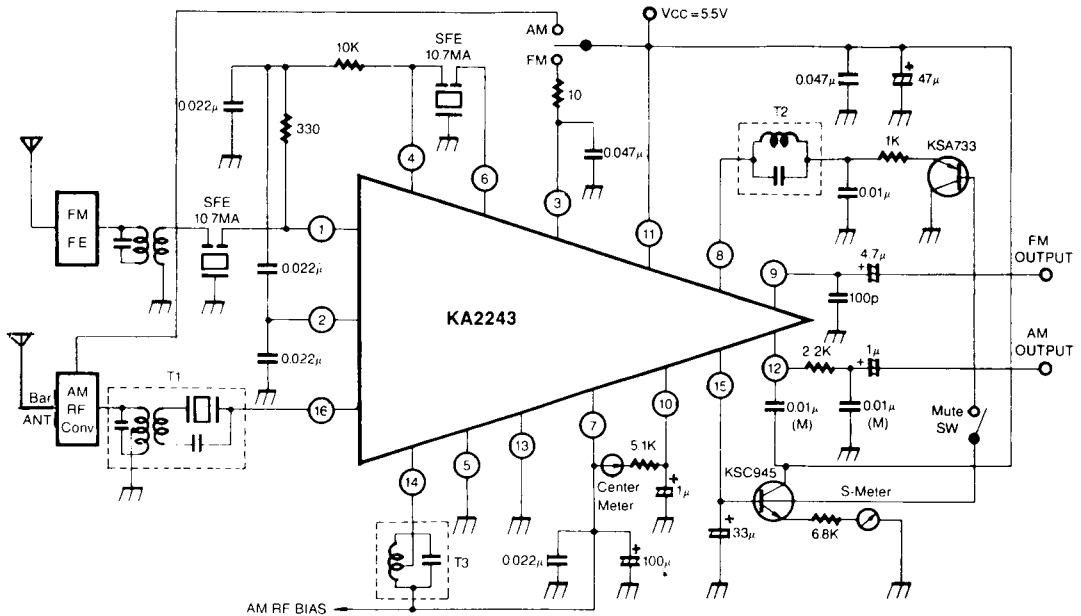
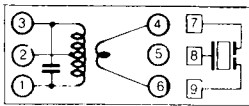

Fig. 2

COIL SPECIFICATION

1. T1



C _o (pF)	f (KHz)	Q _o (%)	TURNS		
			4-6	3-2	2-1
180	455	105	6	93	55

Seoul Jupa
SJ-015-552
0.06mmφ UEW

2. T2

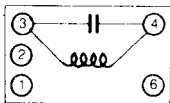

C _o (pF)	f (MHz)	Q _o (%)	TURNS		
			3-4		
82	10.7	65	9		

Seoul Jupa
SJ-59JG-043
0.07mmφ UEW

3. T3

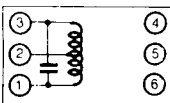

C _o (pF)	f (KHz)	Q _o (%)	TURNS	
			1-2	2-3
180	455	120	51	92

Seoul Jupa
SJ-015-521
0.07mmφ UEW