

KA78XXE/KA78XXAE

3-Terminal 1A Positive Voltage Regulator

Features

- Output Current up to 1A
- Output Voltages of 5, 6, 8, 9, 12, 15, 18, 24V
- Thermal Overload Protection
- Short Circuit Protection
- Output Transistor Safe Operating Area Protection

Description

The KA78XXE/KA78XXAE series of three-terminal positive regulator are available in the TO-220/D-PAK package and with several fixed output voltages, making them useful in a wide range of applications. Each type employs internal current limiting, thermal shut down and safe operating area protection, making it essentially indestructible. If adequate heat sinking is provided, they can deliver over 1A output current. Although designed primarily as fixed voltage regulators, these devices can be used with external components to obtain adjustable voltages and currents.

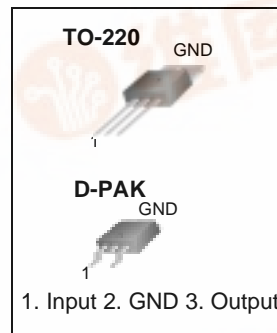

Internal Block Diagram

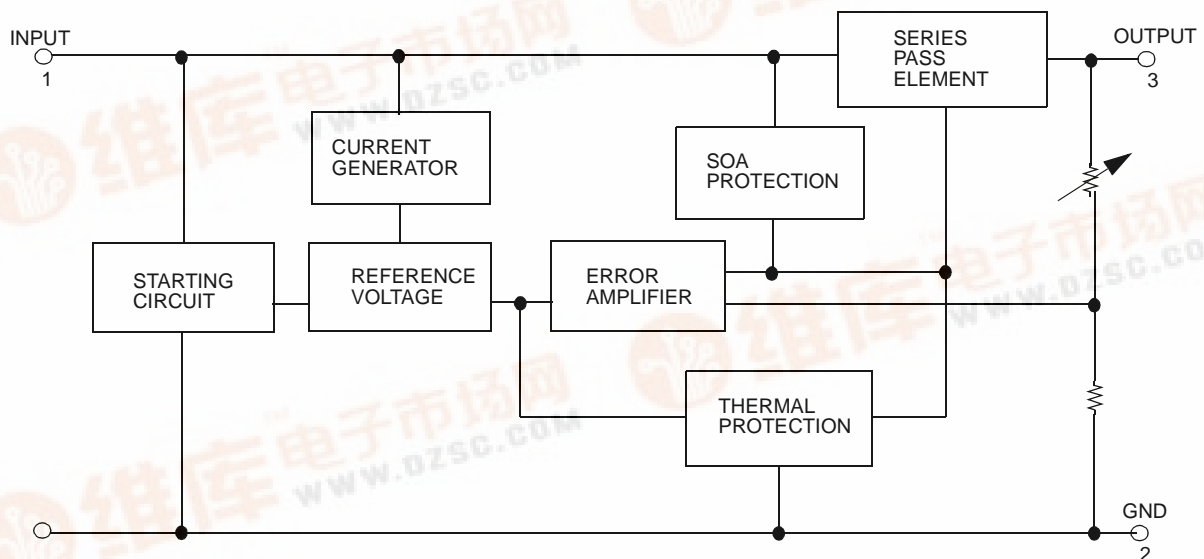

Absolute Maximum Ratings

Parameter	Symbol	Value	Unit
Input Voltage (for $V_O = 5V$ to $18V$) (for $V_O = 24V$)	V_I	35	V
	V_I	40	V
Thermal Resistance Junction-Cases (TO-220)	$R_{\theta JC}$	5	$^{\circ}C/W$
Thermal Resistance Junction-Air (TO-220)	$R_{\theta JA}$	65	$^{\circ}C/W$
Operating Temperature Range (KA78XXE/AE/ER)	TOPR	0 ~ +125	$^{\circ}C$
Storage Temperature Range	TSTG	-65 ~ +150	$^{\circ}C$

Electrical Characteristics (KA7805E/KA7805ER)

(Refer to test circuit, $0^{\circ}C < T_J < 125^{\circ}C$, $I_O = 500mA$, $V_I = 10V$, $C_I = 0.33\mu F$, $C_O = 0.1\mu F$, unless otherwise specified)

Parameter	Symbol	Conditions	KA7805E			Unit	
			Min.	Typ.	Max.		
Output Voltage	V_O	$T_J = +25^{\circ}C$	4.8	5.0	5.2	V	
		$5.0mA \leq I_O \leq 1.0A$, $P_O \leq 15W$ $V_I = 7V$ to $20V$	4.75	5.0	5.25		
Line Regulation (Note1)	Regline	$T_J = +25^{\circ}C$	$V_O = 7V$ to $25V$	-	4.0	100	mV
			$V_I = 8V$ to $12V$	-	1.6	50	
Load Regulation (Note1)	Regload	$T_J = +25^{\circ}C$	$I_O = 5.0mA$ to $1.5A$	-	9	100	mV
			$I_O = 250mA$ to $750mA$	-	4	50	
Quiescent Current	I_Q	$T_J = +25^{\circ}C$	-	5.0	8.0	mA	
Quiescent Current Change	ΔI_Q	$I_O = 5mA$ to $1.0A$	-	0.03	0.5	mA	
		$V_I = 7V$ to $25V$	-	0.3	1.3		
Output Voltage Drift (Note2)	$\Delta V_O / \Delta T$	$I_O = 5mA$	-	-0.8	-	$mV/^{\circ}C$	
Output Noise Voltage	V_N	$f = 10Hz$ to $100kHz$, $T_A = +25^{\circ}C$	-	42	-	$\mu V/V_O$	
Ripple Rejection (Note2)	RR	$f = 120Hz$ $V_O = 8V$ to $18V$	62	73	-	dB	
Dropout Voltage	V_{Drop}	$I_O = 1A$, $T_J = +25^{\circ}C$	-	2	-	V	
Output Resistance (Note2)	r_O	$f = 1kHz$	-	15	-	$m\Omega$	
Short Circuit Current	I_{SC}	$V_I = 35V$, $T_A = +25^{\circ}C$	-	230	-	mA	
Peak Current (Note2)	I_{PK}	$T_J = +25^{\circ}C$	-	2.2	-	A	

Note:

1. Load and line regulation are specified at constant junction temperature. Changes in V_O due to heating effects must be taken into account separately. Pulse testing with low duty is used.
2. These parameters, although guaranteed, are not 100% tested in production.

Electrical Characteristics (KA7806E/KA7806ER) (Continued)(Refer to test circuit, $0^{\circ}\text{C} < T_J < 125^{\circ}\text{C}$, $I_O = 500\text{mA}$, $V_I = 11\text{V}$, $C_I = 0.33\mu\text{F}$, $C_O = 0.1\mu\text{F}$, unless otherwise specified)

Parameter	Symbol	Conditions	KA7806E			Unit	
			Min.	Typ.	Max.		
Output Voltage	V_O	$T_J = +25^{\circ}\text{C}$	5.75	6.0	6.25	V	
		$5.0\text{mA} \leq I_O \leq 1.0\text{A}$, $P_O \leq 15\text{W}$ $V_I = 8.0\text{V to } 21\text{V}$	5.7	6.0	6.3		
Line Regulation (Note1)	Regline	$T_J = +25^{\circ}\text{C}$	$V_I = 8\text{V to } 25\text{V}$	-	5	120	mV
			$V_I = 9\text{V to } 13\text{V}$	-	1.5	60	
Load Regulation (Note1)	Regload	$T_J = +25^{\circ}\text{C}$	$I_O = 5\text{mA to } 1.5\text{A}$	-	9	120	mV
			$I_O = 250\text{mA to } 750\text{mA}$	-	3	60	
Quiescent Current	I_Q	$T_J = +25^{\circ}\text{C}$	-	5.0	8.0	mA	
Quiescent Current Change	ΔI_Q	$I_O = 5\text{mA to } 1\text{A}$	-	-	0.5	mA	
		$V_I = 8\text{V to } 25\text{V}$	-	-	1.3		
Output Voltage Drift (Note2)	$\Delta V_O / \Delta T$	$I_O = 5\text{mA}$	-	-0.8	-	mV/ $^{\circ}\text{C}$	
Output Noise Voltage	V_N	$f = 10\text{Hz to } 100\text{kHz}$, $T_A = +25^{\circ}\text{C}$	-	45	-	$\mu\text{V}/V_O$	
Ripple Rejection (Note2)	RR	$f = 120\text{Hz}$ $V_I = 9\text{V to } 19\text{V}$	59	75	-	dB	
Dropout Voltage	V_{Drop}	$I_O = 1\text{A}$, $T_J = +25^{\circ}\text{C}$	-	2	-	V	
Output Resistance(Note2)	r_O	$f = 1\text{kHz}$	-	19	-	$\text{m}\Omega$	
Short Circuit Current	I_{SC}	$V_I = 35\text{V}$, $T_A = +25^{\circ}\text{C}$	-	250	-	mA	
Peak Current (Note2)	I_{PK}	$T_J = +25^{\circ}\text{C}$	-	2.2	-	A	

Note:

1. Load and line regulation are specified at constant junction temperature. Changes in V_O due to heating effects must be taken into account separately. Pulse testing with low duty is used.
2. These parameters, although guaranteed, are not 100% tested in production.

Electrical Characteristics (KA7808E/KA7808ER) (Continued)(Refer to test circuit, $0^{\circ}\text{C} < T_J < 125^{\circ}\text{C}$, $I_O = 500\text{mA}$, $V_I = 14\text{V}$, $C_I = 0.33\mu\text{F}$, $C_O = 0.1\mu\text{F}$, unless otherwise specified)

Parameter	Symbol	Conditions	KA7808E			Unit	
			Min.	Typ.	Max.		
Output Voltage	V _O	T _J = +25°C	7.7	8.0	8.3	V	
		5.0mA ≤ I _O ≤ 1.0A, P _O ≤ 15W V _I = 10.5V to 23V	7.6	8.0	8.4		
Line Regulation (Note1)	Regline	T _J = +25°C	V _I = 10.5V to 25V	-	5.0	160	mV
			V _I = 11.5V to 17V	-	2.0	80	
Load Regulation (Note1)	Regload	T _J = +25°C	I _O = 5.0mA to 1.5A	-	10	160	mV
			I _O = 250mA to 750mA	-	5.0	80	
Quiescent Current	I _Q	T _J = +25°C	-	5.0	8.0	mA	
Quiescent Current Change	ΔI _Q	I _O = 5mA to 1.0A	-	0.05	0.5	mA	
		V _I = 10.5A to 25V	-	0.5	1.0		
Output Voltage Drift (Note2)	ΔV _O /ΔT	I _O = 5mA	-	-0.8	-	mV/°C	
Output Noise Voltage	V _N	f = 10Hz to 100kHz, T _A = +25°C	-	52	-	μV/V _O	
Ripple Rejection (Note2)	RR	f = 120Hz, V _I = 11.5V to 21.5V	56	73	-	dB	
Dropout Voltage	V _{Drop}	I _O = 1A, T _J = +25°C	-	2	-	V	
Output Resistance (Note2)	r _O	f = 1kHz	-	17	-	mΩ	
Short Circuit Current	I _{SC}	V _I = 35V, T _A = +25°C	-	230	-	mA	
Peak Current (Note2)	I _{PK}	T _J = +25°C	-	2.2	-	A	

Note:

1. Load and line regulation are specified at constant junction temperature. Changes in V_O due to heating effects must be taken into account separately. Pulse testing with low duty is used.
2. These parameters, although guaranteed, are not 100% tested in production.

Electrical Characteristics (KA7809E/KA7809ER) (Continued)(Refer to test circuit, $0^{\circ}\text{C} < T_J < 125^{\circ}\text{C}$, $I_O = 500\text{mA}$, $V_I = 15\text{V}$, $C_I = 0.33\mu\text{F}$, $C_O = 0.1\mu\text{F}$, unless otherwise specified)

Parameter	Symbol	Conditions	KA7809E			Unit	
			Min.	Typ.	Max.		
Output Voltage	V_O	$T_J = +25^{\circ}\text{C}$	8.65	9	9.35	V	
		$5.0\text{mA} \leq I_O \leq 1.0\text{A}$, $P_O \leq 15\text{W}$ $V_I = 11.5\text{V to } 24\text{V}$	8.6	9	9.4		
Line Regulation (Note1)	Regline	$T_J = +25^{\circ}\text{C}$	$V_I = 11.5\text{V to } 25\text{V}$	-	6	180	mV
			$V_I = 12\text{V to } 17\text{V}$	-	2	90	
Load Regulation (Note1)	Regload	$T_J = +25^{\circ}\text{C}$	$I_O = 5\text{mA to } 1.5\text{A}$	-	12	180	mV
			$I_O = 250\text{mA to } 750\text{mA}$	-	4	90	
Quiescent Current	I_Q	$T_J = +25^{\circ}\text{C}$	-	5.0	8.0	mA	
Quiescent Current Change	ΔI_Q	$I_O = 5\text{mA to } 1.0\text{A}$	-	-	0.5	mA	
		$V_I = 11.5\text{V to } 26\text{V}$	-	-	1.3		
Output Voltage Drift (Note2)	$\Delta V_O / \Delta T$	$I_O = 5\text{mA}$	-	-1	-	mV/ $^{\circ}\text{C}$	
Output Noise Voltage	V_N	$f = 10\text{Hz to } 100\text{kHz}$, $T_A = +25^{\circ}\text{C}$	-	58	-	$\mu\text{V}/V_O$	
Ripple Rejection (Note2)	RR	$f = 120\text{Hz}$ $V_I = 13\text{V to } 23\text{V}$	56	71	-	dB	
Dropout Voltage	V_{Drop}	$I_O = 1\text{A}$, $T_J = +25^{\circ}\text{C}$	-	2	-	V	
Output Resistance (Note2)	r_O	$f = 1\text{kHz}$	-	17	-	$\text{m}\Omega$	
Short Circuit Current	ISC	$V_I = 35\text{V}$, $T_A = +25^{\circ}\text{C}$	-	250	-	mA	
Peak Current (Note2)	IPK	$T_J = +25^{\circ}\text{C}$	-	2.2	-	A	

Note:

1. Load and line regulation are specified at constant junction temperature. Changes in V_O due to heating effects must be taken into account separately. Pulse testing with low duty is used.
2. These parameters, although guaranteed, are not 100% tested in production.

Electrical Characteristics (KA7812E/KA7812ER) (Continued)(Refer to test circuit, $0^{\circ}\text{C} < T_J < 125^{\circ}\text{C}$, $I_O = 500\text{mA}$, $V_I = 19\text{V}$, $C_I = 0.33\mu\text{F}$, $C_O = 0.1\mu\text{F}$, unless otherwise specified)

Parameter	Symbol	Conditions	KA7812E/KA7812ER			Unit	
			Min.	Typ.	Max.		
Output Voltage	V_O	$T_J = +25^{\circ}\text{C}$	11.5	12	12.5	V	
		$5.0\text{mA} \leq I_O \leq 1.0\text{A}$, $P_O \leq 15\text{W}$ $V_I = 14.5\text{V to } 27\text{V}$	11.4	12	12.6		
Line Regulation (Note1)	Regline	$T_J = +25^{\circ}\text{C}$	$V_I = 14.5\text{V to } 30\text{V}$	-	10	240	mV
			$V_I = 16\text{V to } 22\text{V}$	-	3.0	120	
Load Regulation (Note1)	Regload	$T_J = +25^{\circ}\text{C}$	$I_O = 5\text{mA to } 1.5\text{A}$	-	11	240	mV
			$I_O = 250\text{mA to } 750\text{mA}$	-	5.0	120	
Quiescent Current	I_Q	$T_J = +25^{\circ}\text{C}$	-	5.1	8.0	mA	
Quiescent Current Change	ΔI_Q	$I_O = 5\text{mA to } 1.0\text{A}$	-	0.1	0.5	mA	
		$V_I = 14.5\text{V to } 30\text{V}$	-	0.5	1.0		
Output Voltage Drift (Note2)	$\Delta V_O / \Delta T$	$I_O = 5\text{mA}$	-	-1	-	mV/ $^{\circ}\text{C}$	
Output Noise Voltage	V_N	$f = 10\text{Hz to } 100\text{kHz}$, $T_A = +25^{\circ}\text{C}$	-	76	-	$\mu\text{V}/V_O$	
Ripple Rejection (Note2)	RR	$f = 120\text{Hz}$ $V_I = 15\text{V to } 25\text{V}$	55	71	-	dB	
Dropout Voltage	V_{Drop}	$I_O = 1\text{A}$, $T_J = +25^{\circ}\text{C}$	-	2	-	V	
Output Resistance (Note2)	r_O	$f = 1\text{kHz}$	-	18	-	$\text{m}\Omega$	
Short Circuit Current	ISC	$V_I = 35\text{V}$, $T_A = +25^{\circ}\text{C}$	-	230	-	mA	
Peak Current (Note2)	IPK	$T_J = +25^{\circ}\text{C}$	-	2.2	-	A	

Note:

1. Load and line regulation are specified at constant junction temperature. Changes in V_O due to heating effects must be taken into account separately. Pulse testing with low duty is used.
2. These parameters, although guaranteed, are not 100% tested in production.

Electrical Characteristics (KA7815E) (Continued)(Refer to test circuit, $0^{\circ}\text{C} < T_J < 125^{\circ}\text{C}$, $I_O = 500\text{mA}$, $V_I = 23\text{V}$, $C_I = 0.33\mu\text{F}$, $C_O = 0.1\mu\text{F}$, unless otherwise specified)

Parameter	Symbol	Conditions	KA7815E			Unit	
			Min.	Typ.	Max.		
Output Voltage	V_O	$T_J = +25^{\circ}\text{C}$	14.4	15	15.6	V	
		$5.0\text{mA} \leq I_O \leq 1.0\text{A}$, $P_O \leq 15\text{W}$ $V_I = 17.5\text{V to } 30\text{V}$	14.25	15	15.75		
Line Regulation (Note1)	Regline	$T_J = +25^{\circ}\text{C}$	$V_I = 17.5\text{V to } 30\text{V}$	-	11	300	mV
			$V_I = 20\text{V to } 26\text{V}$	-	3	150	
Load Regulation (Note1)	Regload	$T_J = +25^{\circ}\text{C}$	$I_O = 5\text{mA to } 1.5\text{A}$	-	12	300	mV
			$I_O = 250\text{mA to } 750\text{mA}$	-	4	150	
Quiescent Current	I_Q	$T_J = +25^{\circ}\text{C}$	-	5.2	8.0	mA	
Quiescent Current Change	ΔI_Q	$I_O = 5\text{mA to } 1.0\text{A}$	-	-	0.5	mA	
		$V_I = 17.5\text{V to } 30\text{V}$	-	-	1.0		
Output Voltage Drift (Note2)	$\Delta V_O / \Delta T$	$I_O = 5\text{mA}$	-	-1	-	mV/ $^{\circ}\text{C}$	
Output Noise Voltage	V_N	$f = 10\text{Hz to } 100\text{kHz}$, $T_A = +25^{\circ}\text{C}$	-	90	-	$\mu\text{V}/V_O$	
Ripple Rejection (Note2)	RR	$f = 120\text{Hz}$ $V_I = 18.5\text{V to } 28.5\text{V}$	54	70	-	dB	
Dropout Voltage	V_{Drop}	$I_O = 1\text{A}$, $T_J = +25^{\circ}\text{C}$	-	2	-	V	
Output Resistance (Note2)	r_O	$f = 1\text{kHz}$	-	19	-	$\text{m}\Omega$	
Short Circuit Current	I_{SC}	$V_I = 35\text{V}$, $T_A = +25^{\circ}\text{C}$	-	250	-	mA	
Peak Current (Note2)	I_{PK}	$T_J = +25^{\circ}\text{C}$	-	2.2	-	A	

Note:

1. Load and line regulation are specified at constant junction temperature. Changes in V_O due to heating effects must be taken into account separately. Pulse testing with low duty is used.
2. These parameters, although guaranteed, are not 100% tested in production.

Electrical Characteristics (KA7818E) (Continued)(Refer to test circuit, $0^{\circ}\text{C} < T_J < 125^{\circ}\text{C}$, $I_O = 500\text{mA}$, $V_I = 27\text{V}$, $C_I = 0.33\mu\text{F}$, $C_O = 0.1\mu\text{F}$, unless otherwise specified)

Parameter	Symbol	Conditions	KA7818E			Unit	
			Min.	Typ.	Max.		
Output Voltage	V_O	$T_J = +25^{\circ}\text{C}$	17.3	18	18.7	V	
		$5.0\text{mA} \leq I_O \leq 1.0\text{A}$, $P_O \leq 15\text{W}$ $V_I = 21\text{V to } 33\text{V}$	17.1	18	18.9		
Line Regulation (Note1)	Regline	$T_J = +25^{\circ}\text{C}$	$V_I = 21\text{V to } 33\text{V}$	-	15	360	mV
			$V_I = 24\text{V to } 30\text{V}$	-	5	180	
Load Regulation (Note1)	Regload	$T_J = +25^{\circ}\text{C}$	$I_O = 5\text{mA to } 1.5\text{A}$	-	15	360	mV
			$I_O = 250\text{mA to } 750\text{mA}$	-	5.0	180	
Quiescent Current	I_Q	$T_J = +25^{\circ}\text{C}$	-	5.2	8.0	mA	
Quiescent Current Change	ΔI_Q	$I_O = 5\text{mA to } 1.0\text{A}$	-	-	0.5	mA	
		$V_I = 21\text{V to } 33\text{V}$	-	-	1		
Output Voltage Drift (Note2)	$\Delta V_O / \Delta T$	$I_O = 5\text{mA}$	-	-1	-	mV/ $^{\circ}\text{C}$	
Output Noise Voltage	V_N	$f = 10\text{Hz to } 100\text{kHz}$, $T_A = +25^{\circ}\text{C}$	-	110	-	$\mu\text{V}/V_O$	
Ripple Rejection (Note2)	RR	$f = 120\text{Hz}$ $V_I = 22\text{V to } 32\text{V}$	53	69	-	dB	
Dropout Voltage	V_{Drop}	$I_O = 1\text{A}$, $T_J = +25^{\circ}\text{C}$	-	2	-	V	
Output Resistance (Note2)	r_O	$f = 1\text{kHz}$	-	22	-	$\text{m}\Omega$	
Short Circuit Current	I_{SC}	$V_I = 35\text{V}$, $T_A = +25^{\circ}\text{C}$	-	250	-	mA	
Peak Current (Note2)	I_{PK}	$T_J = +25^{\circ}\text{C}$	-	2.2	-	A	

Note:

1. Load and line regulation are specified at constant junction temperature. Changes in V_O due to heating effects must be taken into account separately. Pulse testing with low duty is used.
2. These parameters, although guaranteed, are not 100% tested in production.

Electrical Characteristics (KA7824E) (Continued)(Refer to test circuit, $0^{\circ}\text{C} < T_J < 125^{\circ}\text{C}$, $I_O = 500\text{mA}$, $V_I = 33\text{V}$, $C_I = 0.33\mu\text{F}$, $C_O = 0.1\mu\text{F}$, unless otherwise specified)

Parameter	Symbol	Conditions	KA7824E			Unit	
			Min.	Typ.	Max.		
Output Voltage	V_O	$T_J = +25^{\circ}\text{C}$	23	24	25	V	
		$5.0\text{mA} \leq I_O \leq 1.0\text{A}$, $P_O \leq 15\text{W}$ $V_I = 27\text{V to } 38\text{V}$	22.8	24	25.25		
Line Regulation (Note1)	Regline	$T_J = +25^{\circ}\text{C}$	$V_I = 27\text{V to } 38\text{V}$	-	17	480	mV
			$V_I = 30\text{V to } 36\text{V}$	-	6	240	
Load Regulation (Note1)	Regload	$T_J = +25^{\circ}\text{C}$	$I_O = 5\text{mA to } 1.5\text{A}$	-	15	480	mV
			$I_O = 250\text{mA to } 750\text{mA}$	-	5.0	240	
Quiescent Current	I_Q	$T_J = +25^{\circ}\text{C}$	-	5.2	8.0	mA	
Quiescent Current Change	ΔI_Q	$I_O = 5\text{mA to } 1.0\text{A}$	-	0.1	0.5	mA	
		$V_I = 27\text{V to } 38\text{V}$	-	0.5	1		
Output Voltage Drift (Note2)	$\Delta V_O / \Delta T$	$I_O = 5\text{mA}$	-	-1.5	-	mV/ $^{\circ}\text{C}$	
Output Noise Voltage	V_N	$f = 10\text{Hz to } 100\text{kHz}$, $T_A = +25^{\circ}\text{C}$	-	60	-	$\mu\text{V}/V_O$	
Ripple Rejection (Note2)	RR	$f = 120\text{Hz}$ $V_I = 28\text{V to } 38\text{V}$	50	67	-	dB	
Dropout Voltage	V_{Drop}	$I_O = 1\text{A}$, $T_J = +25^{\circ}\text{C}$	-	2	-	V	
Output Resistance (Note2)	r_O	$f = 1\text{kHz}$	-	28	-	$\text{m}\Omega$	
Short Circuit Current	I_{SC}	$V_I = 35\text{V}$, $T_A = +25^{\circ}\text{C}$	-	230	-	mA	
Peak Current (Note2)	I_{PK}	$T_J = +25^{\circ}\text{C}$	-	2.2	-	A	

Note:

1. Load and line regulation are specified at constant junction temperature. Changes in V_O due to heating effects must be taken into account separately. Pulse testing with low duty is used.
2. These parameters, although guaranteed, are not 100% tested in production.

Electrical Characteristics (KA7805AE) (Continued)(Refer to the test circuits. $0^{\circ}\text{C} < T_J < +125^{\circ}\text{C}$, $I_O = 1\text{A}$, $V_I = 10\text{V}$, $C_I = 0.33\mu\text{F}$, $C_O = 0.1\mu\text{F}$, unless otherwise specified)

Parameter	Symbol	Conditions	Min.	Typ.	Max.	Unit	
Output Voltage	V_O	$T_J = +25^{\circ}\text{C}$	4.9	5	5.1	V	
		$I_O = 5\text{mA to } 1\text{A}$, $P_O \leq 15\text{W}$ $V_I = 7.5\text{V to } 20\text{V}$	4.8	5	5.2		
Line Regulation (Note1)	Regline	$V_I = 7.5\text{V to } 25\text{V}$ $I_O = 500\text{mA}$	-	5	50	mV	
		$V_I = 8\text{V to } 12\text{V}$	-	3	50		
		$T_J = +25^{\circ}\text{C}$	$V_I = 7.3\text{V to } 20\text{V}$	-	5		50
			$V_I = 8\text{V to } 12\text{V}$	-	1.5		25
Load Regulation (Note1)	Regload	$T_J = +25^{\circ}\text{C}$ $I_O = 5\text{mA to } 1.5\text{A}$	-	9	100	mV	
		$I_O = 5\text{mA to } 1\text{A}$	-	9	100		
		$I_O = 250\text{mA to } 750\text{mA}$	-	4	50		
Quiescent Current	I_Q	$T_J = +25^{\circ}\text{C}$	-	5.0	6.0	mA	
Quiescent Current Change	ΔI_Q	$I_O = 5\text{mA to } 1\text{A}$	-	-	0.5	mA	
		$V_I = 8\text{V to } 25\text{V}$, $I_O = 500\text{mA}$	-	-	0.8		
		$V_I = 7.5\text{V to } 20\text{V}$, $T_J = +25^{\circ}\text{C}$	-	-	0.8		
Output Voltage Drift (Note2)	$\Delta V/\Delta T$	$I_O = 5\text{mA}$	-	-0.8	-	mV/ $^{\circ}\text{C}$	
Output Noise Voltage	V_N	$f = 10\text{Hz to } 100\text{kHz}$ $T_A = +25^{\circ}\text{C}$	-	10	-	$\mu\text{V}/V_O$	
Ripple Rejection (Note2)	RR	$f = 120\text{Hz}$, $I_O = 500\text{mA}$ $V_I = 8\text{V to } 18\text{V}$	-	68	-	dB	
Dropout Voltage	V_{Drop}	$I_O = 1\text{A}$, $T_J = +25^{\circ}\text{C}$	-	2	-	V	
Output Resistance (Note2)	r_O	$f = 1\text{kHz}$	-	17	-	$\text{m}\Omega$	
Short Circuit Current	I_{SC}	$V_I = 35\text{V}$, $T_A = +25^{\circ}\text{C}$	-	250	-	mA	
Peak Current (Note2)	I_{PK}	$T_J = +25^{\circ}\text{C}$	-	2.2	-	A	

Note:

1. Load and line regulation are specified at constant junction temperature. Change in V_O due to heating effects must be taken into account separately. Pulse testing with low duty is used.
2. These parameters, although guaranteed, are not 100% tested in production.

Electrical Characteristics (KA7806AE) (Continued)(Refer to the test circuits. $0^{\circ}\text{C} < T_J < +125^{\circ}\text{C}$, $I_O = 1\text{A}$, $V_I = 11\text{V}$, $C_I = 0.33\mu\text{F}$, $C_O = 0.1\mu\text{F}$, unless otherwise specified)

Parameter	Symbol	Conditions	Min.	Typ.	Max.	Unit	
Output Voltage	V_O	$T_J = +25^{\circ}\text{C}$	5.58	6	6.12	V	
		$I_O = 5\text{mA to } 1\text{A}$, $P_O \leq 15\text{W}$ $V_I = 8.6\text{V to } 21\text{V}$	5.76	6	6.24		
Line Regulation (Note1)	Regline	$V_I = 8.6\text{V to } 25\text{V}$, $I_O = 500\text{mA}$	-	5	60	mV	
		$V_I = 9\text{V to } 13\text{V}$	-	3	60		
		$T_J = +25^{\circ}\text{C}$	$V_I = 8.3\text{V to } 21\text{V}$	-	5		60
			$V_I = 9\text{V to } 13\text{V}$	-	1.5		30
Load Regulation (Note1)	Regload	$T_J = +25^{\circ}\text{C}$, $I_O = 5\text{mA to } 1.5\text{A}$	-	9	100	mV	
		$I_O = 5\text{mA to } 1\text{A}$	-	4	100		
		$I_O = 250\text{mA to } 750\text{mA}$	-	5.0	50		
Quiescent Current	I_Q	$T_J = +25^{\circ}\text{C}$	-	4.3	6.0	mA	
Quiescent Current Change	ΔI_Q	$I_O = 5\text{mA to } 1\text{A}$	-	-	0.5	mA	
		$V_I = 9\text{V to } 25\text{V}$, $I_O = 500\text{mA}$	-	-	0.8		
		$V_I = 8.5\text{V to } 21\text{V}$, $T_J = +25^{\circ}\text{C}$	-	-	0.8		
Output Voltage Drift (Note2)	$\Delta V/\Delta T$	$I_O = 5\text{mA}$	-	-0.8	-	mV/ $^{\circ}\text{C}$	
Output Noise Voltage	V_N	$f = 10\text{Hz to } 100\text{kHz}$, $T_A = +25^{\circ}\text{C}$	-	10	-	$\mu\text{V}/V_O$	
Ripple Rejection (Note2)	RR	$f = 120\text{Hz}$, $I_O = 500\text{mA}$ $V_I = 9\text{V to } 19\text{V}$	-	65	-	dB	
Dropout Voltage	V_{Drop}	$I_O = 1\text{A}$, $T_J = +25^{\circ}\text{C}$	-	2	-	V	
Output Resistance (Note2)	r_O	$f = 1\text{kHz}$	-	17	-	$\text{m}\Omega$	
Short Circuit Current	I_{SC}	$V_I = 35\text{V}$, $T_A = +25^{\circ}\text{C}$	-	250	-	mA	
Peak Current (Note2)	I_{PK}	$T_J = +25^{\circ}\text{C}$	-	2.2	-	A	

Note:

1. Load and line regulation are specified at constant junction temperature. Change in V_O due to heating effects must be taken into account separately. Pulse testing with low duty is used.
2. These parameters, although guaranteed, are not 100% tested in production.

Electrical Characteristics (KA7808AE) (Continued)(Refer to the test circuits. $0^{\circ}\text{C} < T_J < +125^{\circ}\text{C}$, $I_O = 1\text{A}$, $V_I = 14\text{V}$, $C_I = 0.33\mu\text{F}$, $C_O = 0.1\mu\text{F}$, unless otherwise specified)

Parameter	Symbol	Conditions	Min.	Typ.	Max.	Unit	
Output Voltage	V_O	$T_J = +25^{\circ}\text{C}$	7.84	8	8.16	V	
		$I_O = 5\text{mA to } 1\text{A}$, $P_O \leq 15\text{W}$ $V_I = 10.6\text{V to } 23\text{V}$	7.7	8	8.3		
Line Regulation (Note1)	Regline	$V_I = 10.6\text{V to } 25\text{V}$, $I_O = 500\text{mA}$	-	6	80	mV	
		$V_I = 11\text{V to } 17\text{V}$	-	3	80		
		$T_J = +25^{\circ}\text{C}$	$V_I = 10.4\text{V to } 23\text{V}$	-	6		80
			$V_I = 11\text{V to } 17\text{V}$	-	2		40
Load Regulation (Note1)	Regload	$T_J = +25^{\circ}\text{C}$, $I_O = 5\text{mA to } 1.5\text{A}$	-	12	100	mV	
		$I_O = 5\text{mA to } 1\text{A}$	-	12	100		
		$I_O = 250\text{mA to } 750\text{mA}$	-	5	50		
Quiescent Current	I_Q	$T_J = +25^{\circ}\text{C}$	-	5.0	6.0	mA	
Quiescent Current Change	ΔI_Q	$I_O = 5\text{mA to } 1\text{A}$	-	-	0.5	mA	
		$V_I = 11\text{V to } 25\text{V}$, $I_O = 500\text{mA}$	-	-	0.8		
		$V_I = 10.6\text{V to } 23\text{V}$, $T_J = +25^{\circ}\text{C}$	-	-	0.8		
Output Voltage Drift (Note2)	$\Delta V/\Delta T$	$I_O = 5\text{mA}$	-	-0.8	-	mV/ $^{\circ}\text{C}$	
Output Noise Voltage	V_N	$f = 10\text{Hz to } 100\text{kHz}$, $T_A = +25^{\circ}\text{C}$	-	10	-	$\mu\text{V}/V_O$	
Ripple Rejection (Note2)	RR	$f = 120\text{Hz}$, $I_O = 500\text{mA}$ $V_I = 11.5\text{V to } 21.5\text{V}$	-	62	-	dB	
Dropout Voltage	V_{Drop}	$I_O = 1\text{A}$, $T_J = +25^{\circ}\text{C}$	-	2	-	V	
Output Resistance (Note2)	r_O	$f = 1\text{kHz}$	-	18	-	$\text{m}\Omega$	
Short Circuit Current	I_{SC}	$V_I = 35\text{V}$, $T_A = +25^{\circ}\text{C}$	-	250	-	mA	
Peak Current (Note2)	I_{PK}	$T_J = +25^{\circ}\text{C}$	-	2.2	-	A	

Note:

1. Load and line regulation are specified at constant junction temperature. Change in V_O due to heating effects must be taken into account separately. Pulse testing with low duty is used.
2. These parameters, although guaranteed, are not 100% tested in production.

Electrical Characteristics (KA7809AE) (Continued)(Refer to the test circuits. $0^{\circ}\text{C} < T_J < +125^{\circ}\text{C}$, $I_O = 1\text{A}$, $V_I = 15\text{V}$, $C_I = 0.33\mu\text{F}$, $C_O = 0.1\mu\text{F}$, unless otherwise specified)

Parameter	Symbol	Conditions	Min.	Typ.	Max.	Unit	
Output Voltage	V_O	$T_J = +25^{\circ}\text{C}$	8.82	9.0	9.18	V	
		$I_O = 5\text{mA to } 1\text{A}$, $P_O \leq 15\text{W}$ $V_I = 11.2\text{V to } 24\text{V}$	8.65	9.0	9.35		
Line Regulation (Note1)	Regline	$V_I = 11.7\text{V to } 25\text{V}$, $I_O = 500\text{mA}$	-	6	90	mV	
		$V_I = 12.5\text{V to } 19\text{V}$	-	4	45		
		$T_J = +25^{\circ}\text{C}$	$V_I = 11.5\text{V to } 24\text{V}$	-	6		90
			$V_I = 12.5\text{V to } 19\text{V}$	-	2		45
Load Regulation (Note1)	Regload	$T_J = +25^{\circ}\text{C}$, $I_O = 5\text{mA to } 1.0\text{A}$	-	12	100	mV	
		$I_O = 5\text{mA to } 1.0\text{A}$	-	12	100		
		$I_O = 250\text{mA to } 750\text{mA}$	-	5	50		
Quiescent Current	I_Q	$T_J = +25^{\circ}\text{C}$	-	5.0	6.0	mA	
Quiescent Current Change	ΔI_Q	$V_I = 11.7\text{V to } 25\text{V}$, $T_J = +25^{\circ}\text{C}$	-	-	0.8	mA	
		$V_I = 12\text{V to } 25\text{V}$, $I_O = 500\text{mA}$	-	-	0.8		
		$I_O = 5\text{mA to } 1.0\text{A}$	-	-	0.5		
Output Voltage Drift (Note2)	$\Delta V/\Delta T$	$I_O = 5\text{mA}$	-	-1.0	-	mV/ $^{\circ}\text{C}$	
Output Noise Voltage	V_N	$f = 10\text{Hz to } 100\text{kHz}$, $T_A = +25^{\circ}\text{C}$	-	10	-	$\mu\text{V}/V_O$	
Ripple Rejection (Note2)	RR	$f = 120\text{Hz}$, $I_O = 500\text{mA}$ $V_I = 12\text{V to } 22\text{V}$	-	62	-	dB	
Dropout Voltage	V_{Drop}	$I_O = 1\text{A}$, $T_J = +25^{\circ}\text{C}$	-	2.0	-	V	
Output Resistance (Note2)	r_O	$f = 1\text{kHz}$	-	17	-	$\text{m}\Omega$	
Short Circuit Current	ISC	$V_I = 35\text{V}$, $T_A = +25^{\circ}\text{C}$	-	250	-	mA	
Peak Current (Note2)	IPK	$T_J = +25^{\circ}\text{C}$	-	2.2	-	A	

Note:

1. Load and line regulation are specified at constant junction temperature. Change in V_O due to heating effects must be taken into account separately. Pulse testing with low duty is used.
2. These parameters, although guaranteed, are not 100% tested in production.

Electrical Characteristics (KA7812AE) (Continued)(Refer to the test circuits. $0^{\circ}\text{C} < T_J < +125^{\circ}\text{C}$, $I_O = 1\text{A}$, $V_I = 19\text{V}$, $C_I = 0.33\mu\text{F}$, $C_O = 0.1\mu\text{F}$, unless otherwise specified)

Parameter	Symbol	Conditions	Min.	Typ.	Max.	Unit	
Output Voltage	V_O	$T_J = +25^{\circ}\text{C}$	11.75	12	12.25	V	
		$I_O = 5\text{mA to } 1\text{A}$, $P_O \leq 15\text{W}$ $V_I = 14.8\text{V to } 27\text{V}$	11.5	12	12.5		
Line Regulation (Note1)	Regline	$V_I = 14.8\text{V to } 30\text{V}$, $I_O = 500\text{mA}$	-	10	120	mV	
		$V_I = 16\text{V to } 22\text{V}$	-	4	120		
		$T_J = +25^{\circ}\text{C}$	$V_I = 14.5\text{V to } 27\text{V}$	-	10		120
			$V_I = 16\text{V to } 22\text{V}$	-	3		60
Load Regulation (Note1)	Regload	$T_J = +25^{\circ}\text{C}$, $I_O = 5\text{mA to } 1.5\text{A}$	-	12	100	mV	
		$I_O = 5\text{mA to } 1.0\text{A}$	-	12	100		
		$I_O = 250\text{mA to } 750\text{mA}$	-	5	50		
Quiescent Current	I_Q	$T_J = +25^{\circ}\text{C}$	-	5.1	6.0	mA	
Quiescent Current Change	ΔI_Q	$V_I = 15\text{V to } 30\text{V}$, $T_J = +25^{\circ}\text{C}$	-		0.8	mA	
		$V_I = 14\text{V to } 27\text{V}$, $I_O = 500\text{mA}$	-		0.8		
		$I_O = 5\text{mA to } 1.0\text{A}$	-		0.5		
Output Voltage Drift (Note2)	$\Delta V/\Delta T$	$I_O = 5\text{mA}$	-	-1.0	-	mV/ $^{\circ}\text{C}$	
Output Noise Voltage	V_N	$f = 10\text{Hz to } 100\text{kHz}$, $T_A = +25^{\circ}\text{C}$	-	10	-	$\mu\text{V}/V_O$	
Ripple Rejection (Note2)	RR	$f = 120\text{Hz}$, $I_O = 500\text{mA}$ $V_I = 14\text{V to } 24\text{V}$	-	60	-	dB	
Dropout Voltage	V_{Drop}	$I_O = 1\text{A}$, $T_J = +25^{\circ}\text{C}$	-	2.0	-	V	
Output Resistance (Note2)	r_O	$f = 1\text{kHz}$	-	18	-	$\text{m}\Omega$	
Short Circuit Current	I_{SC}	$V_I = 35\text{V}$, $T_A = +25^{\circ}\text{C}$	-	250	-	mA	
Peak Current (Note2)	I_{PK}	$T_J = +25^{\circ}\text{C}$	-	2.2	-	A	

Note:

1. Load and line regulation are specified at constant junction temperature. Change in V_O due to heating effects must be taken into account separately. Pulse testing with low duty is used.
2. These parameters, although guaranteed, are not 100% tested in production.

Electrical Characteristics (KA7815AE) (Continued)(Refer to the test circuits. $0^{\circ}\text{C} < T_J < +125^{\circ}\text{C}$, $I_O = 1\text{A}$, $V_I = 23\text{V}$, $C_I = 0.33\mu\text{F}$, $C_O = 0.1\mu\text{F}$, unless otherwise specified)

Parameter	Symbol	Conditions	Min.	Typ.	Max.	Unit	
Output Voltage	V_O	$T_J = +25^{\circ}\text{C}$	14.7	15	15.3	V	
		$I_O = 5\text{mA}$ to 1A, $P_O \leq 15\text{W}$ $V_I = 17.7\text{V}$ to 30V	14.4	15	15.6		
Line Regulation (Note1)	Regline	$V_I = 17.9\text{V}$ to 30V, $I_O = 500\text{mA}$	-	10	150	mV	
		$V_I = 20\text{V}$ to 26V	-	5	150		
		$T_J = +25^{\circ}\text{C}$	$V_I = 17.5\text{V}$ to 30V	-	11		150
			$V_I = 20\text{V}$ to 26V	-	3		75
Load Regulation (Note1)	Regload	$T_J = +25^{\circ}\text{C}$, $I_O = 5\text{mA}$ to 1.5A	-	12	100	mV	
		$I_O = 5\text{mA}$ to 1.0A	-	12	100		
		$I_O = 250\text{mA}$ to 750mA	-	5	50		
Quiescent Current	I_Q	$T_J = +25^{\circ}\text{C}$	-	5.2	6.0	mA	
Quiescent Current Change	ΔI_Q	$V_I = 17.5\text{V}$ to 30V, $T_J = +25^{\circ}\text{C}$	-	-	0.8	mA	
		$V_I = 17.5\text{V}$ to 30V, $I_O = 500\text{mA}$	-	-	0.8		
		$I_O = 5\text{mA}$ to 1.0A	-	-	0.5		
Output Voltage Drift (Note2)	$\Delta V/\Delta T$	$I_O = 5\text{mA}$	-	-1.0	-	mV/ $^{\circ}\text{C}$	
Output Noise Voltage	V_N	$f = 10\text{Hz}$ to 100kHz, $T_A = +25^{\circ}\text{C}$	-	10	-	$\mu\text{V}/V_O$	
Ripple Rejection (Note2)	RR	$f = 120\text{Hz}$, $I_O = 500\text{mA}$ $V_I = 18.5\text{V}$ to 28.5V	-	58	-	dB	
Dropout Voltage	V_{Drop}	$I_O = 1\text{A}$, $T_J = +25^{\circ}\text{C}$	-	2.0	-	V	
Output Resistance (Note2)	r_O	$f = 1\text{kHz}$	-	19	-	$\text{m}\Omega$	
Short Circuit Current	I_{SC}	$V_I = 35\text{V}$, $T_A = +25^{\circ}\text{C}$	-	250	-	mA	
Peak Current (Note2)	I_{PK}	$T_J = +25^{\circ}\text{C}$	-	2.2	-	A	

Note:

1. Load and line regulation are specified at constant junction temperature. Change in V_O due to heating effects must be taken into account separately. Pulse testing with low duty is used.
2. These parameters, although guaranteed, are not 100% tested in production.

Electrical Characteristics (KA7818AE) (Continued)(Refer to the test circuits. $0^{\circ}\text{C} < T_J < +125^{\circ}\text{C}$, $I_O = 1\text{A}$, $V_I = 27\text{V}$, $C_I = 0.33\mu\text{F}$, $C_O = 0.1\mu\text{F}$, unless otherwise specified)

Parameter	Symbol	Conditions	Min.	Typ.	Max.	Unit	
Output Voltage	V_O	$T_J = +25^{\circ}\text{C}$	17.64	18	18.36	V	
		$I_O = 5\text{mA}$ to 1A, $P_O \leq 15\text{W}$ $V_I = 21\text{V}$ to 33V	17.3	18	18.7		
Line Regulation (Note1)	Regline	$V_I = 21\text{V}$ to 33V, $I_O = 500\text{mA}$	-	15	180	mV	
		$V_I = 21\text{V}$ to 33V	-	5	180		
		$T_J = +25^{\circ}\text{C}$	$V_I = 20.6\text{V}$ to 33V	-	15		180
			$V_I = 24\text{V}$ to 30V	-	5		90
Load Regulation (Note1)	Regload	$T_J = +25^{\circ}\text{C}$, $I_O = 5\text{mA}$ to 1.5A	-	15	100	mV	
		$I_O = 5\text{mA}$ to 1.0A	-	15	100		
		$I_O = 250\text{mA}$ to 750mA	-	7	50		
Quiescent Current	I_Q	$T_J = +25^{\circ}\text{C}$	-	5.2	6.0	mA	
Quiescent Current Change	ΔI_Q	$V_I = 21\text{V}$ to 33V, $T_J = +25^{\circ}\text{C}$	-	-	0.8	mA	
		$V_I = 21\text{V}$ to 33V, $I_O = 500\text{mA}$	-	-	0.8		
		$I_O = 5\text{mA}$ to 1.0A	-	-	0.5		
Output Voltage Drift (Note2)	$\Delta V/\Delta T$	$I_O = 5\text{mA}$	-	-1.0	-	mV/ $^{\circ}\text{C}$	
Output Noise Voltage	V_N	$f = 10\text{Hz}$ to 100kHz, $T_A = +25^{\circ}\text{C}$	-	10	-	$\mu\text{V}/V_O$	
Ripple Rejection (Note2)	RR	$f = 120\text{Hz}$, $I_O = 500\text{mA}$ $V_I = 22\text{V}$ to 32V	-	57	-	dB	
Dropout Voltage	V_{Drop}	$I_O = 1\text{A}$, $T_J = +25^{\circ}\text{C}$	-	2.0	-	V	
Output Resistance (Note2)	r_O	$f = 1\text{kHz}$	-	19	-	$\text{m}\Omega$	
Short Circuit Current	I_{SC}	$V_I = 35\text{V}$, $T_A = +25^{\circ}\text{C}$	-	250	-	mA	
Peak Current (Note2)	I_{PK}	$T_J = +25^{\circ}\text{C}$	-	2.2	-	A	

Note:

1. Load and line regulation are specified at constant junction temperature. Change in V_O due to heating effects must be taken into account separately. Pulse testing with low duty is used.
2. These parameters, although guaranteed, are not 100% tested in production.

Electrical Characteristics (KA7824AE) (Continued)(Refer to the test circuits. $0^{\circ}\text{C} < T_J < +125^{\circ}\text{C}$, $I_O = 1\text{A}$, $V_I = 33\text{V}$, $C_I = 0.33\mu\text{F}$, $C_O = 0.1\mu\text{F}$, unless otherwise specified)

Parameter	Symbol	Conditions	Min.	Typ.	Max.	Unit	
Output Voltage	V_O	$T_J = +25^{\circ}\text{C}$	23.5	24	24.5	V	
		$I_O = 5\text{mA}$ to 1A , $P_O \leq 15\text{W}$ $V_I = 27.3\text{V}$ to 38V	23	24	25		
Line Regulation (Note1)	Regline	$V_I = 27\text{V}$ to 38V , $I_O = 500\text{mA}$	-	18	240	mV	
		$V_I = 21\text{V}$ to 33V	-	6	240		
		$T_J = +25^{\circ}\text{C}$	$V_I = 26.7\text{V}$ to 38V	-	18		240
			$V_I = 30\text{V}$ to 36V	-	6		120
Load Regulation (Note1)	Regload	$T_J = +25^{\circ}\text{C}$, $I_O = 5\text{mA}$ to 1.5A	-	15	100	mV	
		$I_O = 5\text{mA}$ to 1.0A	-	15	100		
		$I_O = 250\text{mA}$ to 750mA	-	7	50		
Quiescent Current	I_Q	$T_J = +25^{\circ}\text{C}$	-	5.2	6.0	mA	
Quiescent Current Change	ΔI_Q	$V_I = 27.3\text{V}$ to 38V , $T_J = +25^{\circ}\text{C}$	-	-	0.8	mA	
		$V_I = 27.3\text{V}$ to 38V , $I_O = 500\text{mA}$	-	-	0.8		
		$I_O = 5\text{mA}$ to 1.0A	-	-	0.5		
Output Voltage Drift (Note2)	$\Delta V/\Delta T$	$I_O = 5\text{mA}$	-	-1.5	-	mV/ $^{\circ}\text{C}$	
Output Noise Voltage	V_N	$f = 10\text{Hz}$ to 100kHz , $T_A = 25^{\circ}\text{C}$	-	10	-	$\mu\text{V}/V_O$	
Ripple Rejection (Note2)	RR	$f = 120\text{Hz}$, $I_O = 500\text{mA}$ $V_I = 28\text{V}$ to 38V	-	54	-	dB	
Dropout Voltage	V_{Drop}	$I_O = 1\text{A}$, $T_J = +25^{\circ}\text{C}$	-	2.0	-	V	
Output Resistance (Note2)	r_O	$f = 1\text{kHz}$	-	20	-	$\text{m}\Omega$	
Short Circuit Current	I_{SC}	$V_I = 35\text{V}$, $T_A = +25^{\circ}\text{C}$	-	250	-	mA	
Peak Current (Note2)	I_{PK}	$T_J = +25^{\circ}\text{C}$	-	2.2	-	A	

Note:

1. Load and line regulation are specified at constant junction temperature. Change in V_O due to heating effects must be taken into account separately. Pulse testing with low duty is used.
2. These parameters, although guaranteed, are not 100% tested in production.

Typical Performance Characteristics

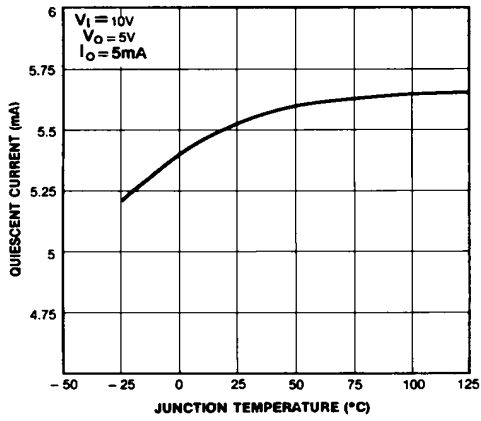

Figure 1. Quiescent Current

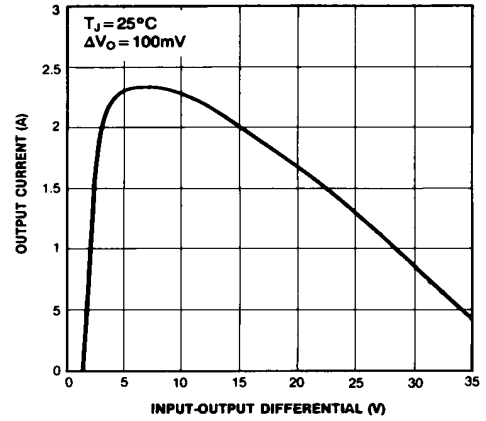

Figure 2. Peak Output Current

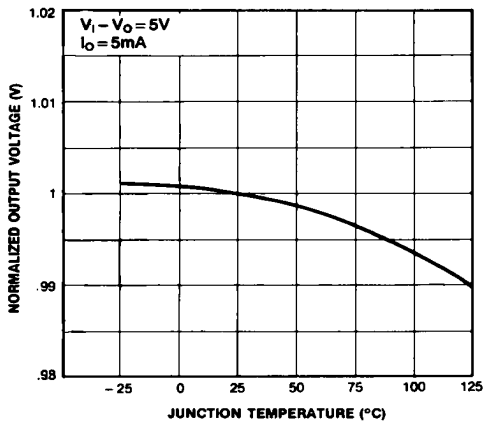

Figure 3. Output Voltage

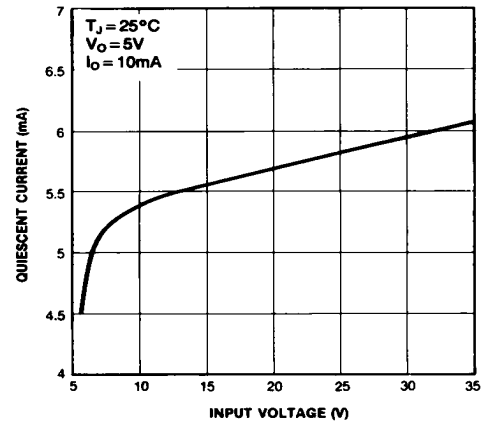

Figure 4. Quiescent Current

Typical Applications

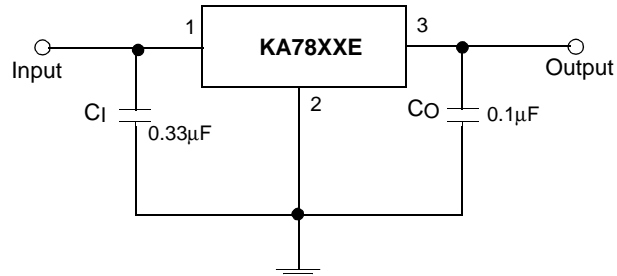

Figure 5. DC Parameters

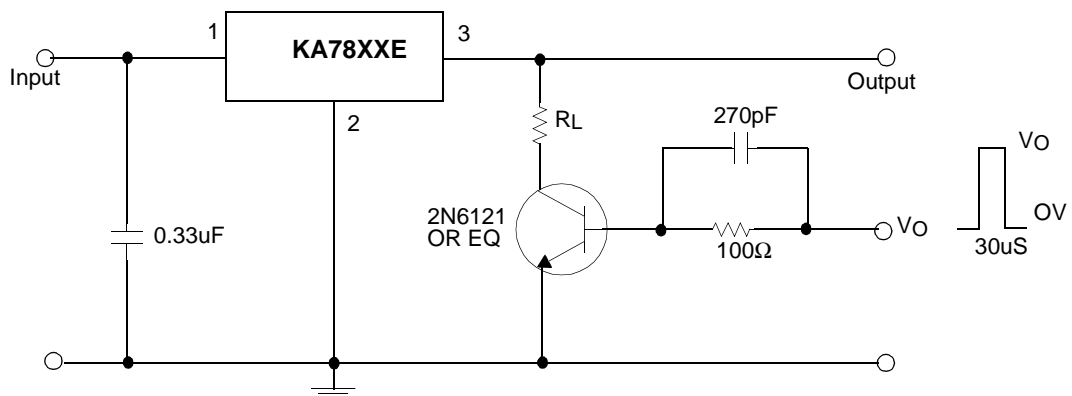

Figure 6. Load Regulation

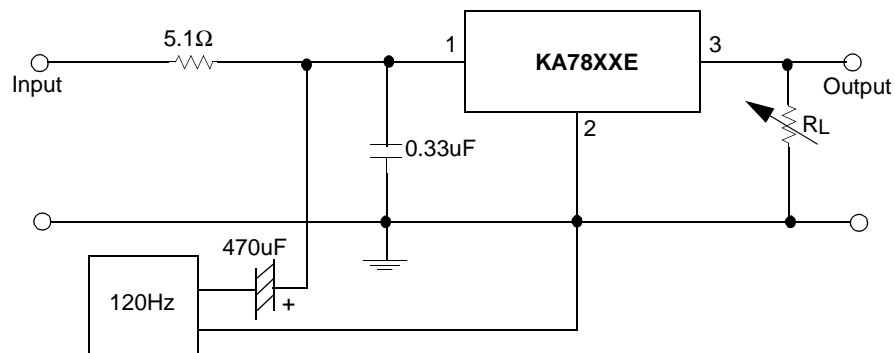

Figure 7. Ripple Rejection

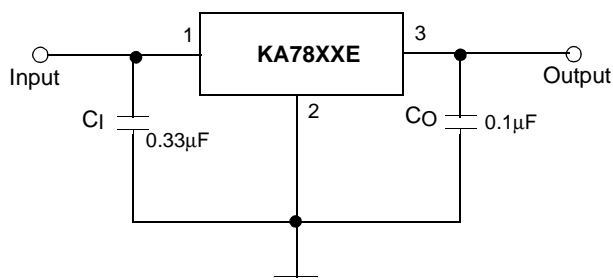

Figure 8. Fixed Output Regulator

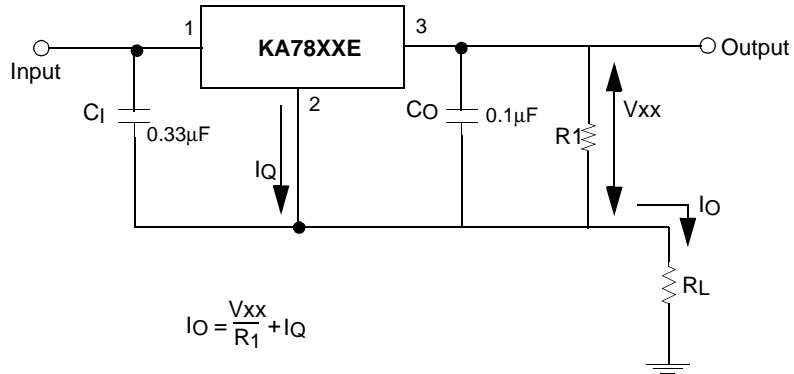
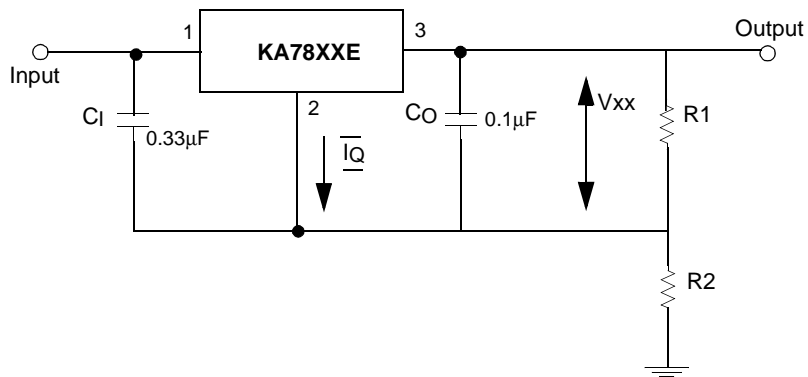

Figure 9. Constant Current Regulator

Notes:

1. To specify an output voltage, substitute voltage value for "XX." A common ground is required between the input and the Output voltage. The input voltage must remain typically 2.0V above the output voltage even during the low point on the input ripple voltage.
2. C1 is required if regulator is located an appreciable distance from power Supply filter.
3. C0 improves stability and transient response.



$$I_{R1} \geq 5I_Q$$

$$V_O = V_{XX}(1+R_2/R_1)+I_Q R_2$$

Figure 10. Circuit for Increasing Output Voltage

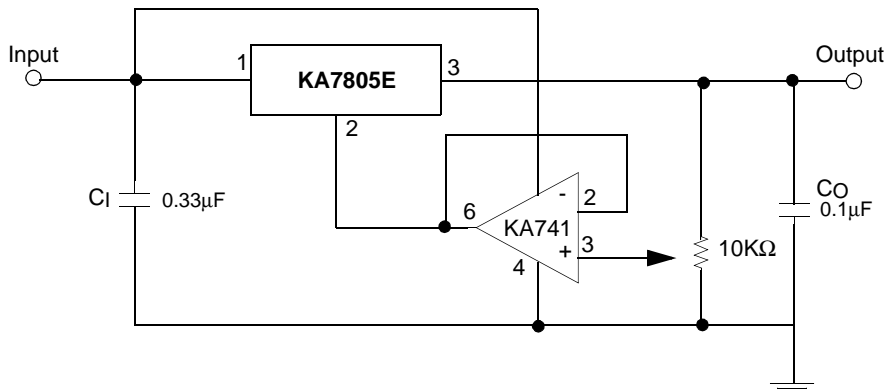

$$I_{R1} \geq 5 I_Q$$

$$V_O = V_{XX}(1+R_2/R_1)+I_Q R_2$$

Figure 11. Adjustable Output Regulator (7 to 30V)

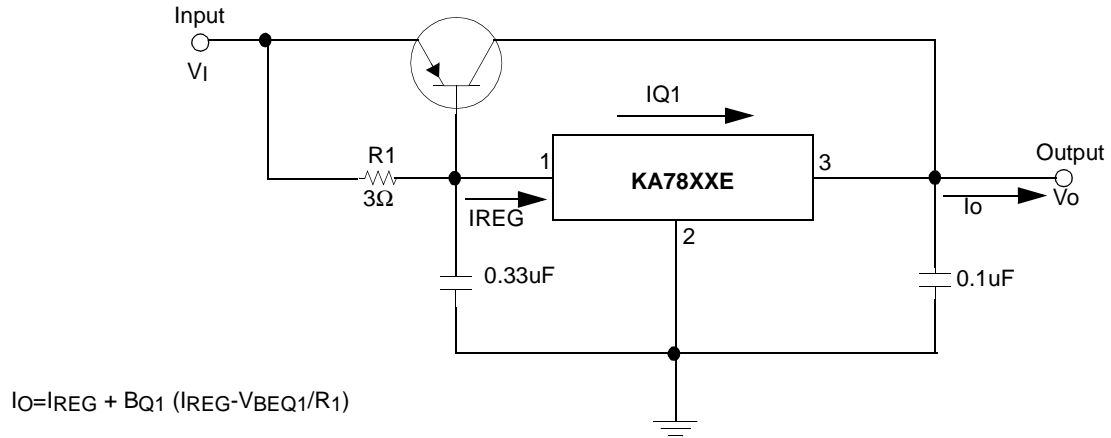

Figure 12. High Current Voltage Regulator

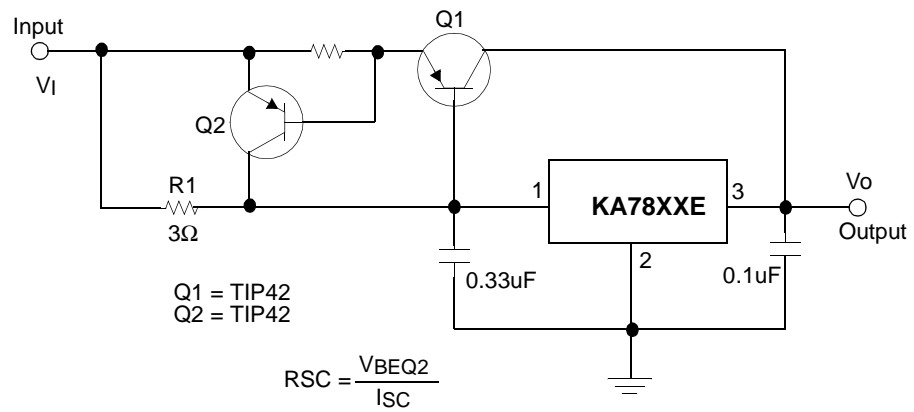

Figure 13. High Output Current with Short Circuit Protection

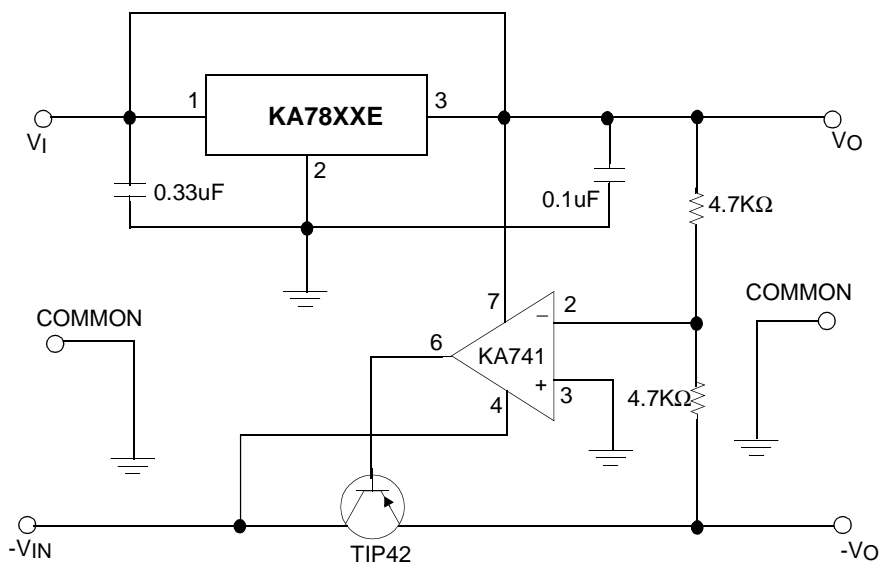

Figure 14. Tracking Voltage Regulator

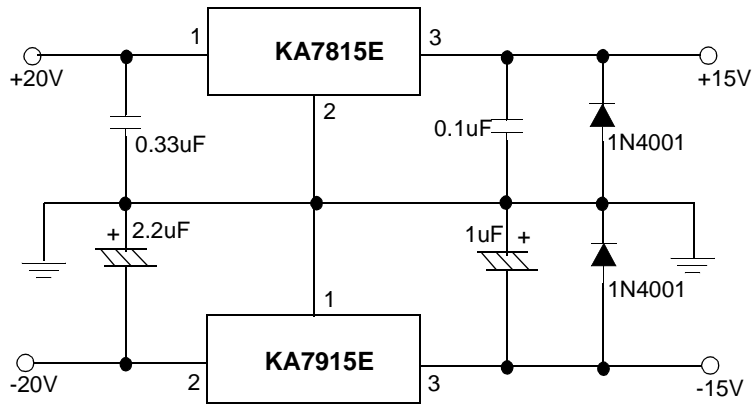

Figure 15. Split Power Supply ($\pm 15V-1A$)

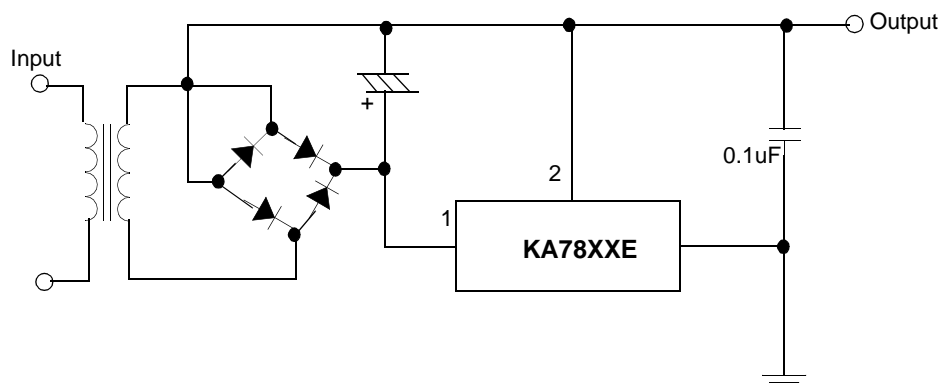

Figure 16. Negative Output Voltage Circuit

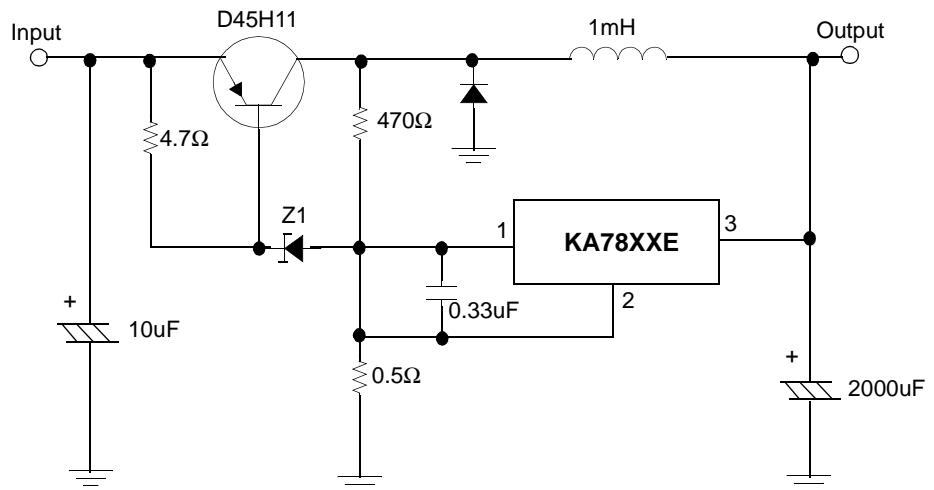

Figure 17. Switching Regulator

Mechanical Dimensions

Package

Dimensions in millimeters

TO-220

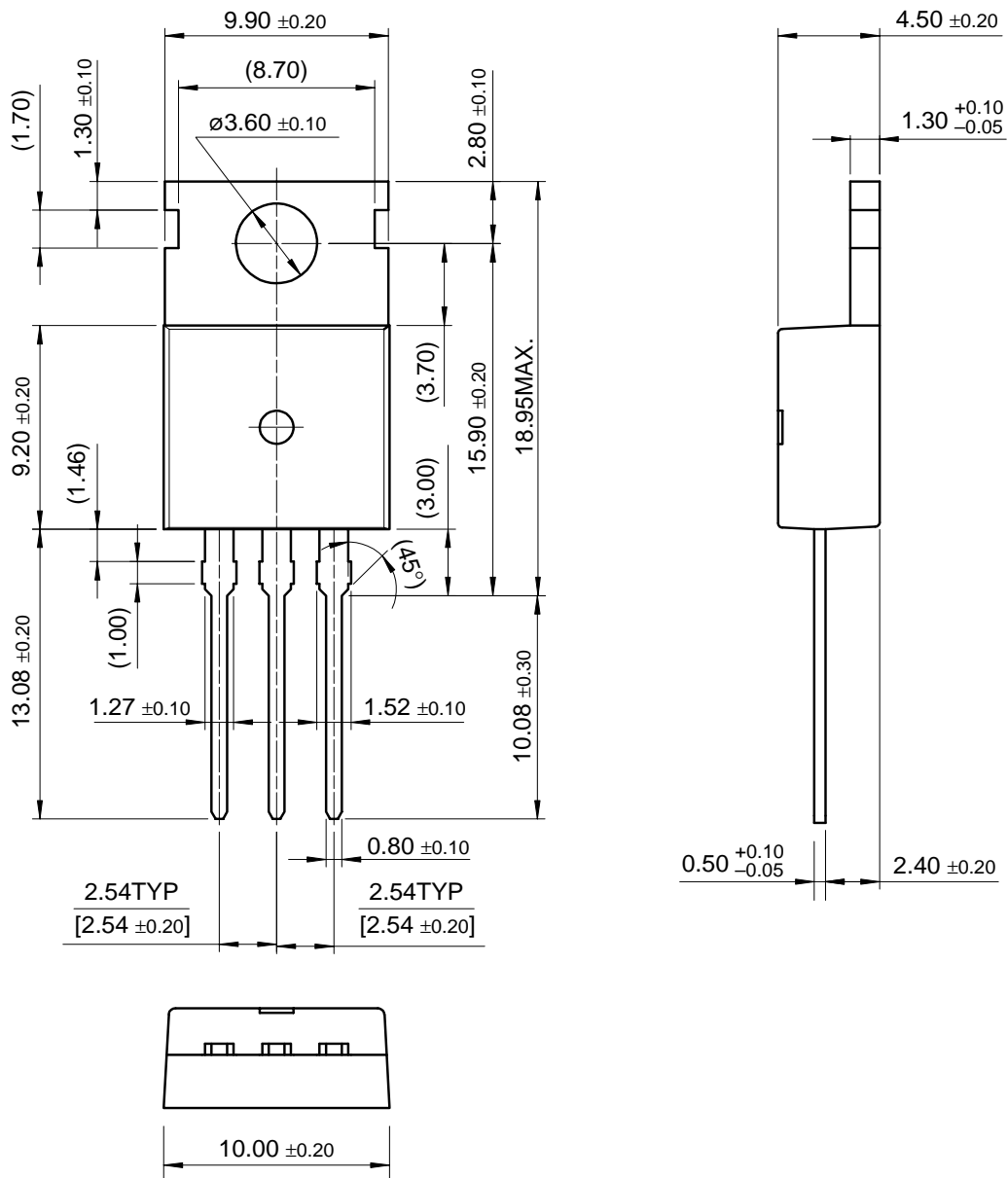

Mechanical Dimensions (Continued)

Package

Dimensions in millimeters

D-PAK

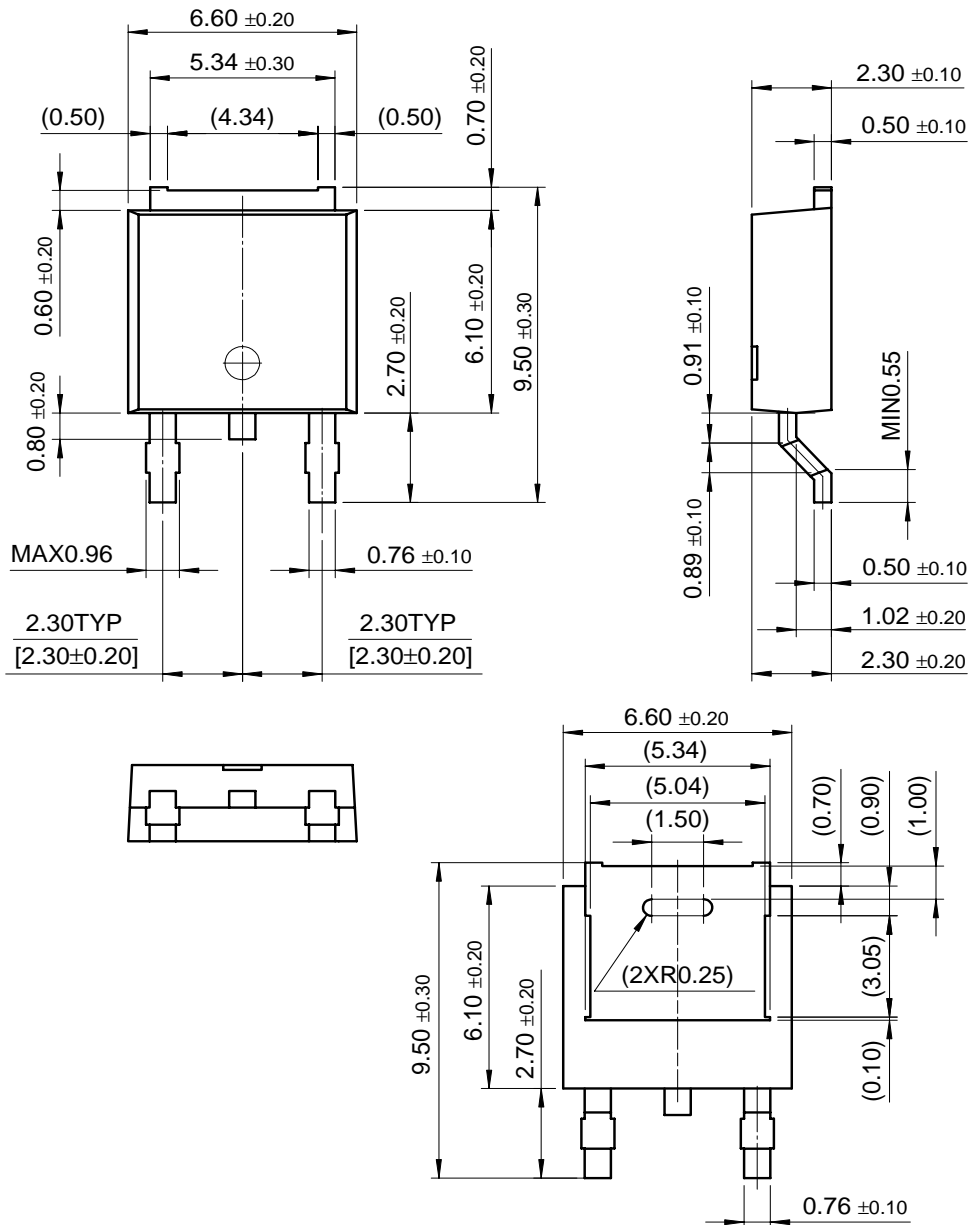

Ordering Information

Product Number	Output Voltage Tolerance	Package	Operating Temperature
KA7805E / KA7806E	±4%	TO-220	0 ~ +125°C
KA7808E / KA7809E			
KA7812E / KA7815E			
KA7818E / KA7824E			
KA7805AE / KA7806AE	±2%		
KA7808AE / KA7809AE			
KA7812AE/KA7815AE			
KA7818AE/KA7824AE			
KA7805ER / KA7806ER	±4%	D-PAK	
KA7808ER / KA7809ER			
KA7812ER			

DISCLAIMER

FAIRCHILD SEMICONDUCTOR RESERVES THE RIGHT TO MAKE CHANGES WITHOUT FURTHER NOTICE TO ANY PRODUCTS HEREIN TO IMPROVE RELIABILITY, FUNCTION OR DESIGN. FAIRCHILD DOES NOT ASSUME ANY LIABILITY ARISING OUT OF THE APPLICATION OR USE OF ANY PRODUCT OR CIRCUIT DESCRIBED HEREIN; NEITHER DOES IT CONVEY ANY LICENSE UNDER ITS PATENT RIGHTS, NOR THE RIGHTS OF OTHERS.

LIFE SUPPORT POLICY

FAIRCHILD'S PRODUCTS ARE NOT AUTHORIZED FOR USE AS CRITICAL COMPONENTS IN LIFE SUPPORT DEVICES OR SYSTEMS WITHOUT THE EXPRESS WRITTEN APPROVAL OF THE PRESIDENT OF FAIRCHILD SEMICONDUCTOR CORPORATION. As used herein:

1. Life support devices or systems are devices or systems which, (a) are intended for surgical implant into the body, or (b) support or sustain life, and (c) whose failure to perform when properly used in accordance with instructions for use provided in the labeling, can be reasonably expected to result in a significant injury of the user.
2. A critical component in any component of a life support device or system whose failure to perform can be reasonably expected to cause the failure of the life support device or system, or to affect its safety or effectiveness.