

KA8513B

FM IF RECEIVER

INTRODUCTION

The KA8513B is designed for FM IF Detection on the pager set. It includes voltage regulator, low battery detection circuit, Mixer, Oscillator, FSK comparator and limiting IF Amplifier.

FEATURES

- Operating Voltage Range : 1.0 ~ 4.0V
- Typical Supply Current : 1.1mA at 1.4V
- Low Battery Detection Circuit (alarm function) : 1.05V
- Voltage Regulator : Vreg = 1.0V (typ)
- Mixer Operating Frequency : 10 ~ 50MHz
- High Transmitting Rate : 1200bps
- FSK Data Reception
- Package Type : 20 ssop (0.65mm)

20-SSOP-225

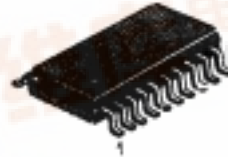

ORDERING INFORMATION

Device	Package	Operating Temperature
KA8513BD	20-SSOP-225	- 20 ~ + 70°C

BLOCK DIAGRAM

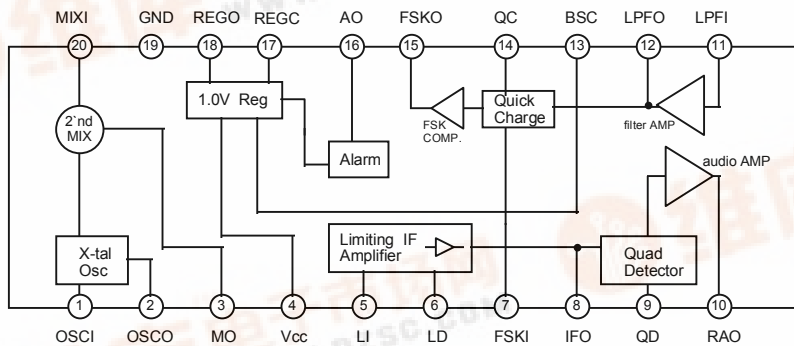

KA8513B

FM IF RECEIVER

PIN CONFIGURATION

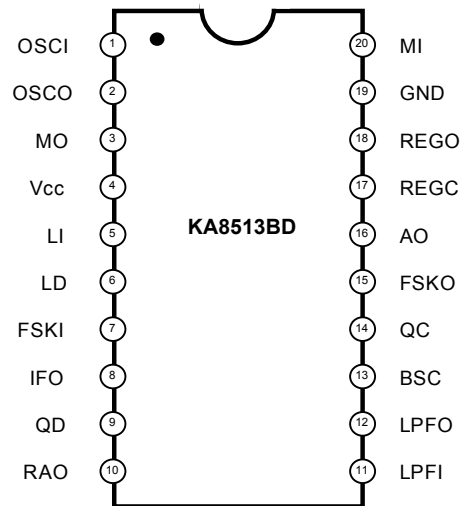

PIN DESCRIPTION

Pin No	Symbol	Description
1	OSCI	Oscillator input. The oscillator is an internally-biased colpitts type.
2	OSCO	Oscillator output.
3	MI	Mixer output pin Output impedance $\approx 2K\Omega$ Connect a 455KHz filter between this pin and the LI.
4	V _{cc}	V _{cc} pin.
5	LI	IF limiter amplifier input. Input impedance $\approx 2K\Omega$
6	LD	Bypass capacitor connect pin for the IF limiter amplifier.

PIN DESCRIPTION (Continued)

Pin No	Symbol	Description
7	FSKI	Differential Amp reference input on the FSK comparator.
8	IFO	IF Amp output.
9	QD	Quadrature detection phase shifter pin.
10	RAO	Recovered audio signal output.
11	LPFI	Low pass filter amplifier input Bias is supplied from pin 10.
12	LPFO	Low pass filter amplifier output.
13	BSC	Battery saving control pin. High : Battery saving off. Low : Battery saving on.
14	QC	Quick charge control pin. High : Quick charge-discharge on. Low : Quick charge-discharge off.
15	FSKO	FSK signal output pin.
16	AO	Alarm output. This pin becomes High when V_{CC} drops below 1.05V
17	REGC	Internal Transistor control pin. Normal mode : open
18	REGO	Regulated voltage output.
19	GND	Ground.
20	MI	Mixer input impedance $\approx 5K\Omega$.

ABSOLUTE MAXIMUM RATINGS (Ta = 25°C)

Characteristic	Symbol	Value	Unit
Max. Supply Voltage	V_{CC} (Max)	4	V
Power Dissipation	P_D	800	mW
Operating Temperature	T_{OPR}	- 20 ~ 70	°C
Storage Temperature	T_{STG}	- 55 ~ 125	°C

ELECTRICAL CHARACTERISTICS(V_{CC} = 1.4V ± 5%, f_{IN(2MIX)} = 21.4MHz, f_{DEV} = ± 4KHz, Ta = 25°C, Unless otherwise specified)

Characteristic	Symbol	Test Conditions	Min	Typ	Max	Unit
Operating Current	I _{CCN}	No Input Signal	-	1.1	1.6	mA
	I _{CCS}	Battery Saving	-	0	10	μA
Alarm Detection Voltage	V _{AD}	-	1.0	1.05	1.1	V
Alarm Low Level Output Voltage	V _{O(AL)}	I = 100μA	-	-	0.4	V
Alarm High Level Leakage Current	I _{LKG(AL)}	-	-	-	2	μA
FSK Low Level Output Voltage	V _{L(FSK)}	I = 100μA	-	-	0.4	V
FSK High Level Leakage Current	I _{LKG(FSK)}	-	-	-	2	μA
Regulator Output Voltage	V _{O(REG)}	-	0.95	1.0	1.05	V
Quick Charge Current	I _C	-	50	70	-	μA
Input for -3dB Sensitivity	V _{LIM}	Mixer Input	-	2.5	7.5	μVrms
Input for -12dB SINAD Sensitivity	V _{I(SEN)}	IF Input	-	6.0	18.0	μVrms
Recovered Audio Output Voltage	V _{O(RAD)}	V _{IN(2MIX)} = 500 μVrms	37	55	73	μVrms
Mixer Conversion Voltage Gain	ΔG _{V(M)}	Ceramic Filter loss = -1dB	8	12	16	dB
Signal to Noise Ratio	S/N	V _{IN(2MIX)} = 500 μVrms	38	55	-	dB
Total Harmonic Distortion	THD	V _{IN(2MIX)} = 500 μVrms	-	2.0	3.5	%
Mixer 3rd Order Intercept Point	3RD	-	-	-10	-	dBm
Mixer Input Resistance	R _{I(MX)}	-	3.5	5	6.5	KΩ
Limiting Amplifier Input Resistance	R _{I(LA)}	-	1.4	2	2.6	KΩ
AM Rejection Ratio	AMR	V _{IN(2MIX)} = 500 μVrms AM = 30%	25	40	-	dB
Data Shapping Output Duty Ratio	DR	V _{IN(2MIX)} = 500 μVrms	40	50	60	%

KA8513B

FM IF RECEIVER

APPLICATION CIRCUIT

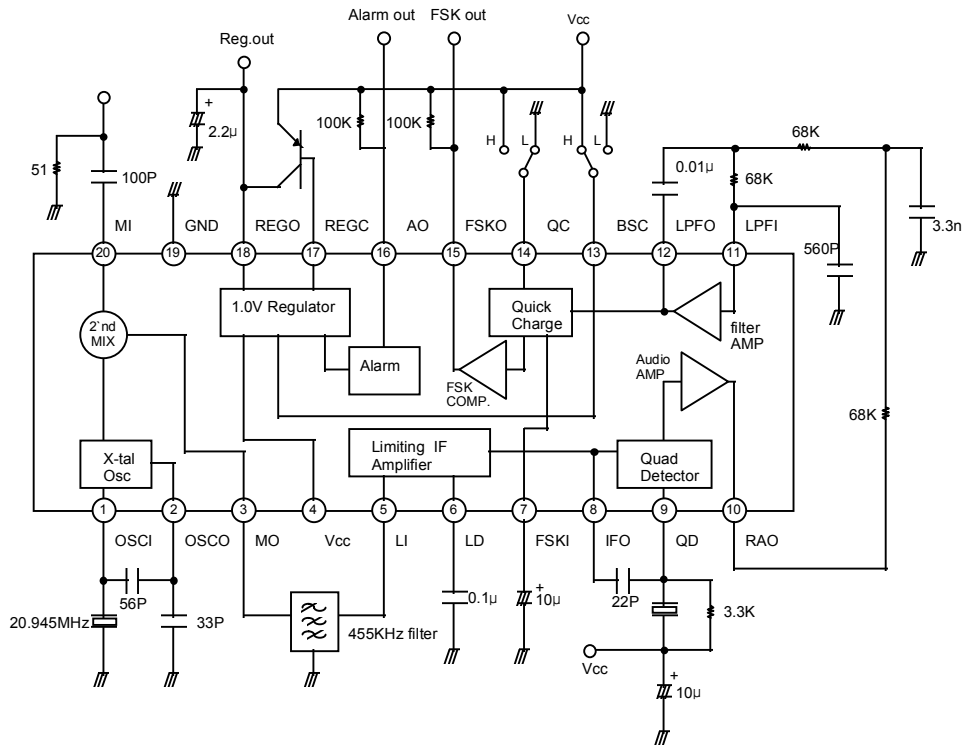

20-SSOP-225

Dimensions in Millimeters/inches

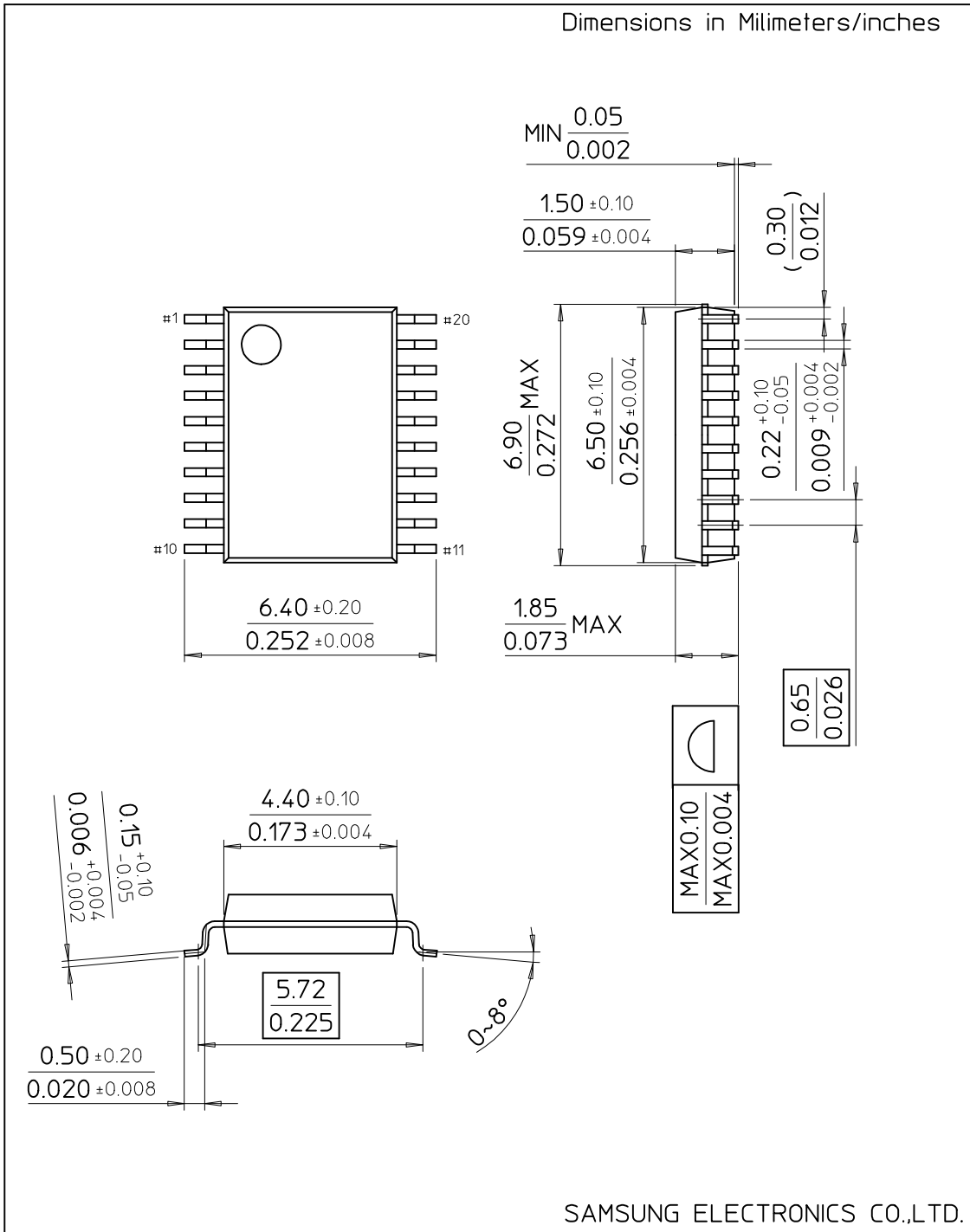

SAMSUNG ELECTRONICS CO.,LTD.