

E2Q0042-27 X2

[查询KGF1608供应商](#)

[捷多邦, 专业PCB打样工厂, 24小时加急
出货](#)

Preliminary

OKI electronic components

KGF1608

This version: Jan. 1998
Previous version: Jun. 1996

Power FET (Ceramic Package Type)

GENERAL DESCRIPTION

The KGF1608, housed in a SMD type ceramic package, is a discrete GaAs power FET that features high efficiency and high output power. The KGF1608 specifications are guaranteed to a fixed matching circuit for 3.4 V and 850 MHz; external impedance-matching circuits are also required. Because of its high efficiency (70% min.), high output power (more than 33 dBm), the KGF1608 is ideal as a transmitter-final-stage amplifier for personal handy phones, such as 3-V digital cellular phones.

FEATURES

- High output power: 33 dBm (min.)
- High efficiency: 70% (min.)
- Specifications guaranteed to a fixed matching circuit for 3.4 V and 850 MHz
- Low thermal resistance: 18°C/W (typ.)
- Package: 3PFP



MARKING

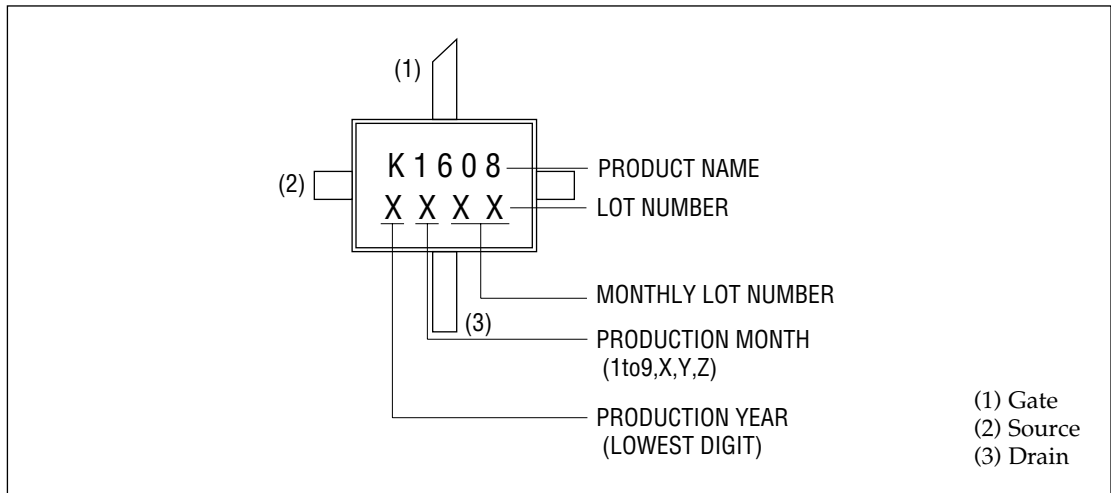

CIRCUIT

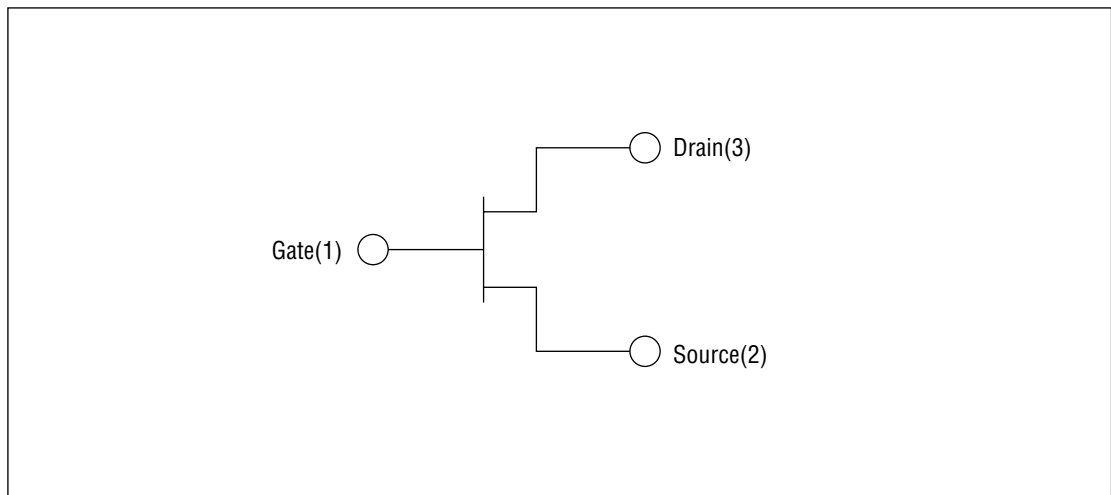

ABSOLUTE MAXIMUM RATINGS

Item	Symbol	Condition	Unit	Min.	Max.
Drain-source voltage	V_{DS}	$T_a = 25^\circ\text{C}$	V	—	8
Gate-source voltage	V_{GS}	$T_a = 25^\circ\text{C}$	V	-5	0.4
Drain current	I_{DS}	$T_a = 25^\circ\text{C}$	A	—	5.5
Total power dissipation	P_{tot}	$T_a = T_c = 25^\circ\text{C}$	W	—	5
Channel temperature	T_{ch}	—	$^\circ\text{C}$	—	150
Storage temperature	T_{stg}	—	$^\circ\text{C}$	-45	125

ELECTRICAL CHARACTERISTICS

(Ta = 25°C)

Item	Symbol	Condition	Unit	Min.	Typ.	Max.
Gate-source leakage current	I_{GSS}	$V_{GS} = -5\text{ V}$	μA	—	—	100
Gate-drain leakage current	I_{GDO}	$V_{GD} = -13\text{ V}$	mA	—	—	3
Drain-source cut-off current	$I_{DS(off)}$	$V_{DS} = 8\text{ V}, V_{GS} = -5\text{ V}$	mA	—	—	3
Drain current	I_{DSS}	$V_{DS} = 1.5\text{ V}, V_{GS} = 0\text{ V}$	A	4.5	—	—
Gate-source cut-off voltage	$V_{GS(off)}$	$V_{DS} = 3\text{ V}, I_{DS} = 11.2\text{ mA}$	V	-3.0	—	-2.0
Output power	P_O	(*1) $P_{IN} = 26\text{ dBm}$	dBm	33	—	—
Drain efficiency	η_D	(*1) $P_{IN} = 26\text{ dBm}$	%	70	—	—
Thermal resistance	R_{th}	Channel to case	$^\circ\text{C/W}$	—	18	—

*1 Condition: $f = 850\text{ MHz}$, $V_{DS} = 3.4\text{ V}$, $I_{DSQ} = 400\text{ mA}$,

RF CHARACTERISTICS

Matching conditions

Gamma S (Source impedance) : $2.29 + j7.27 (\Omega)$

Gamma L (Load impedance) : $4.04 - j0.06 (\Omega)$

Bias conditions

$V_{DS}=3.4 V$, $I_{DSQ}=400 mA$, $f=850 MHz$

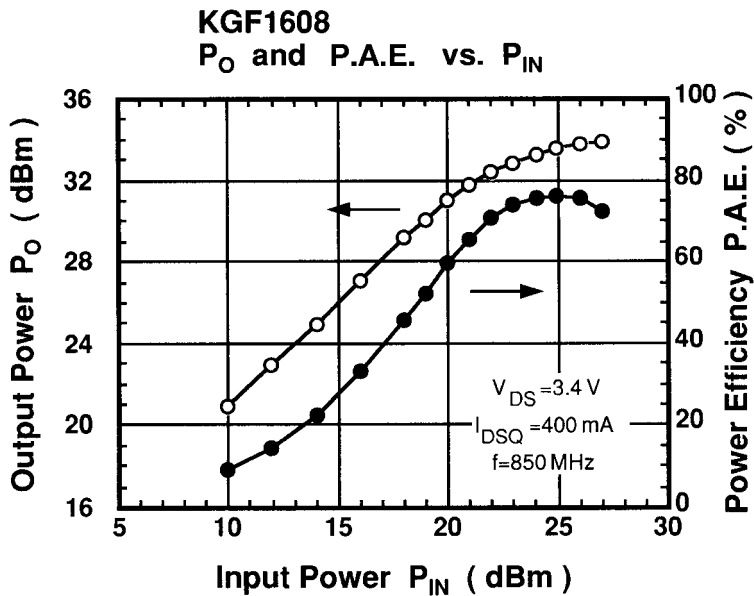
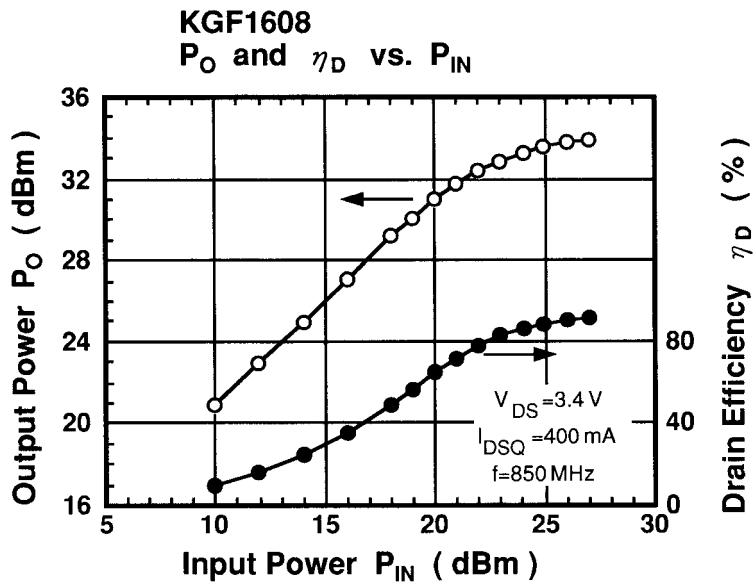

Matching conditions

Gamma S (Source impedance) : $2.29 + j7.27 (\Omega)$

Gamma L (Load impedance) : $4.04 - j0.06 (\Omega)$

Bias conditions

$V_{DS}=3.4\text{ V}$, $I_{DSQ}=400\text{ mA}$, $P_{IN}=26\text{ dBm}$, $f=850\text{ MHz}$

KGF1608

P_O and η_D vs. V_{DS}

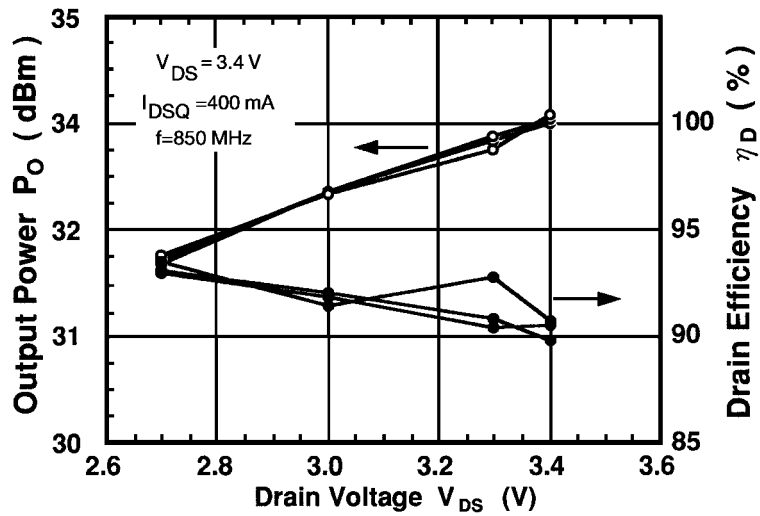

KGF1608

P_O and P.A.E. vs. V_{DS}

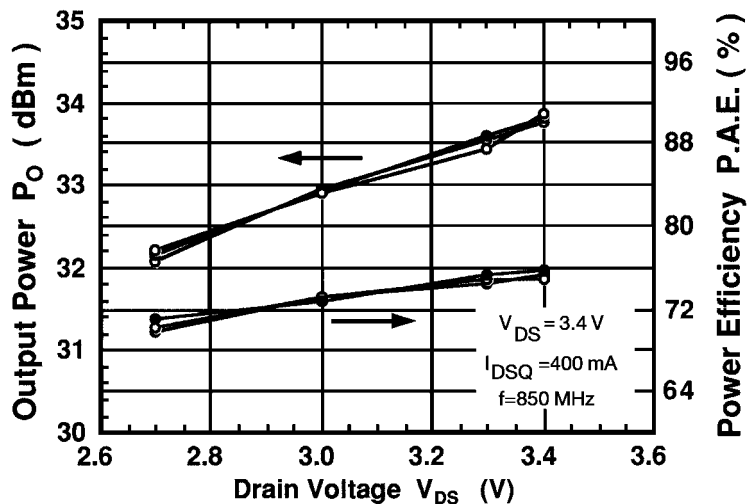

Typical S Parameters

 $V_{DS} = 3.4 \text{ V}$, $I_{DS} = 560 \text{ mA}$

Freq(MHz)	MAG(S ₁₁)	ANG(S ₁₁)	MAG(S ₂₁)	ANG(S ₂₁)	MAG(S ₁₂)	ANG(S ₁₂)	MAG(S ₂₂)	ANG(S ₂₂)
500.0	0.958	-168.53	1.762	87.95	0.016	28.84	0.898	178.40
600.0	0.959	-171.29	1.470	85.37	0.017	30.78	0.899	177.62
700.0	0.958	-173.31	1.257	82.85	0.018	33.13	0.898	177.29
800.0	0.955	-175.06	1.109	80.56	0.019	34.66	0.904	176.14
900.0	0.957	-176.39	0.986	78.66	0.019	36.58	0.898	175.81
1000.0	0.954	-177.67	0.887	76.34	0.020	37.51	0.900	174.70
1100.0	0.953	-178.63	0.813	74.74	0.021	39.65	0.900	174.77
1200.0	0.954	-179.67	0.745	72.54	0.022	40.13	0.898	173.68
1300.0	0.951	179.56	0.695	71.11	0.023	41.96	0.893	173.28
1400.0	0.953	178.68	0.642	69.33	0.024	42.04	0.899	172.53
1500.0	0.949	177.76	0.606	67.29	0.025	43.11	0.891	171.81
1600.0	0.949	177.04	0.569	65.99	0.027	43.61	0.900	171.47
1700.0	0.945	176.52	0.539	63.77	0.028	44.63	0.889	170.58
1800.0	0.947	175.74	0.514	63.03	0.028	44.29	0.901	170.35
1900.0	0.944	174.85	0.490	61.09	0.030	45.10	0.887	169.32
2000.0	0.944	174.49	0.469	59.69	0.031	45.21	0.899	168.90
2100.0	0.943	173.49	0.450	58.28	0.032	45.64	0.887	168.11
2200.0	0.942	173.09	0.433	56.51	0.033	45.49	0.894	167.59
2300.0	0.941	172.34	0.417	55.27	0.035	45.64	0.893	166.58
2400.0	0.939	171.67	0.405	54.21	0.035	45.64	0.889	166.01
2500.0	0.939	171.15	0.389	52.05	0.037	45.69	0.889	164.90
2600.0	0.937	170.39	0.381	51.64	0.037	45.57	0.884	164.75
2700.0	0.935	169.68	0.367	49.25	0.039	45.53	0.887	163.54
2800.0	0.935	169.08	0.362	48.87	0.040	45.27	0.881	163.26
2900.0	0.934	168.44	0.349	46.91	0.042	45.08	0.884	161.99
3000.0	0.932	167.71	0.345	45.70	0.043	44.96	0.879	161.45

Typical S Parameters

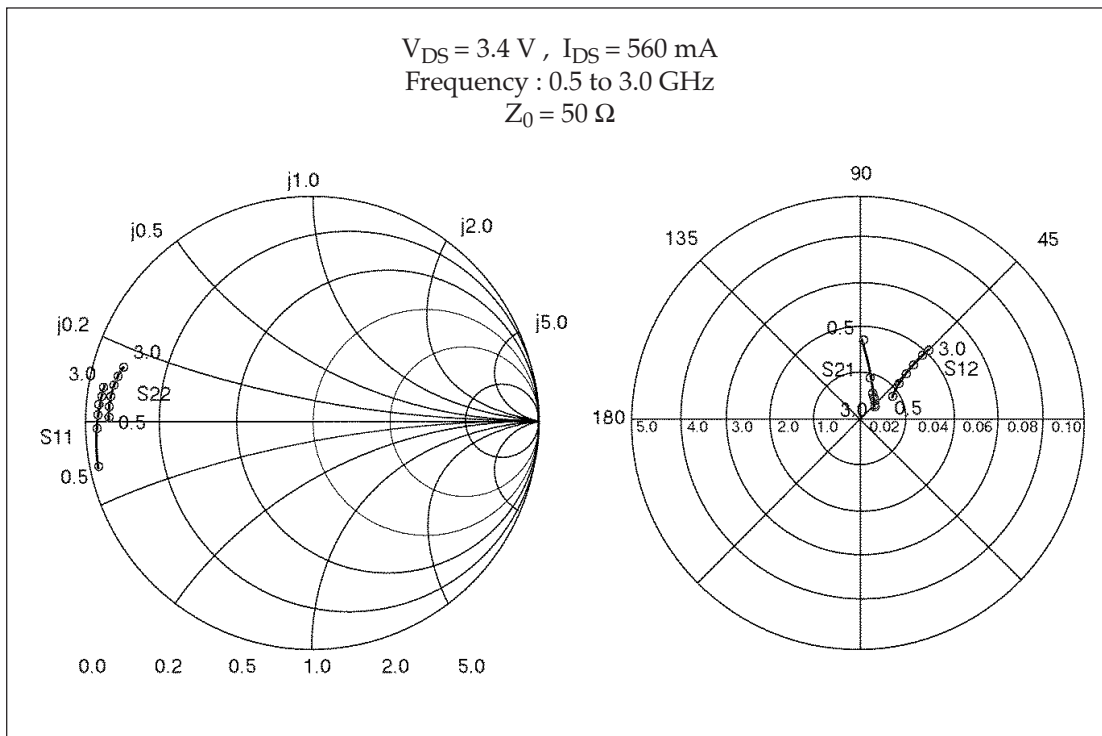

PACKAGE DIMENSIONS

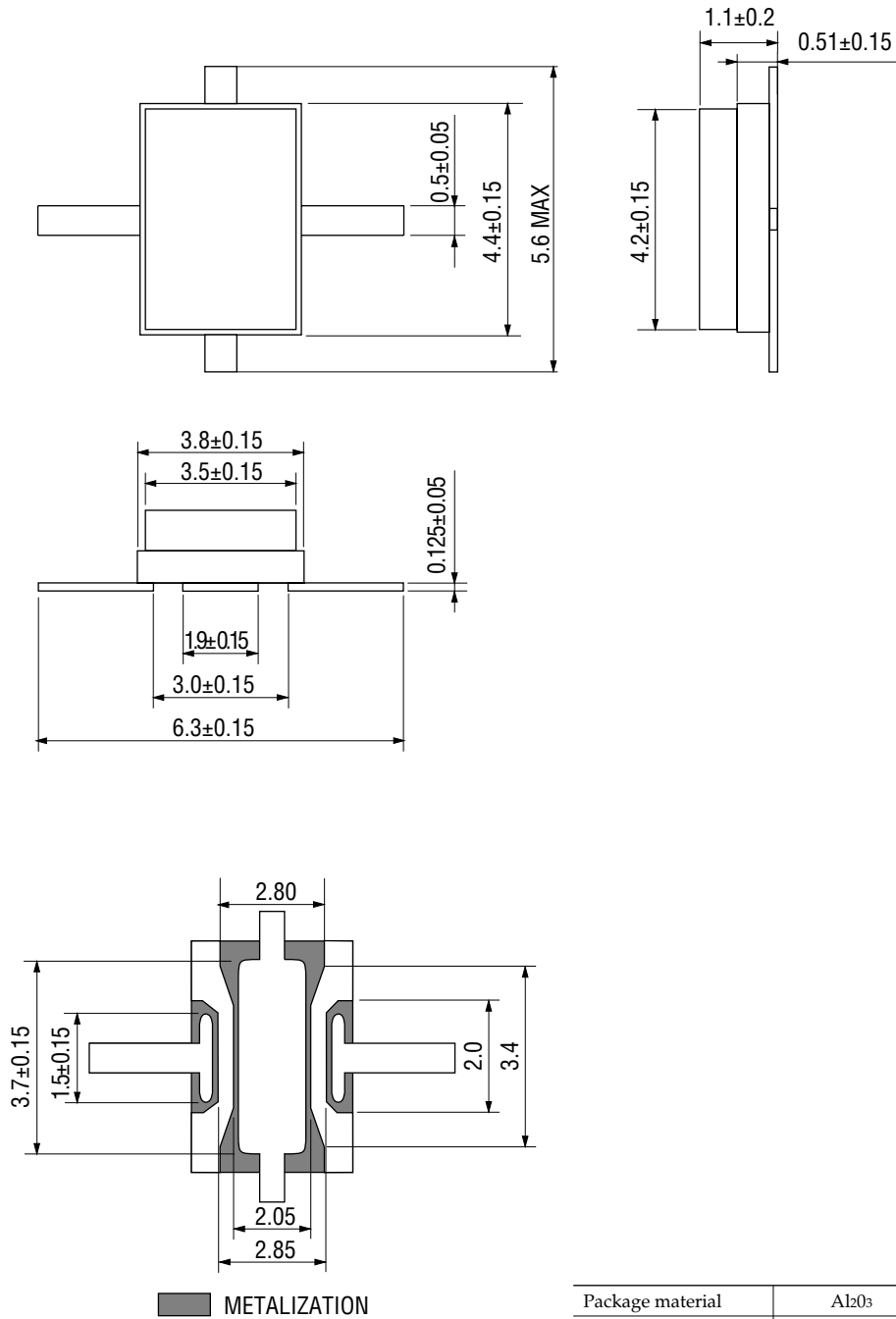

(Unit: mm)

Package material	Al ₂ O ₃
Lead frame material	Fe-Ni-Co alloy
Pin treatment	Ni/Au plating
plate thickness	Au:1.0 μm or more