

KEC

KOREA ELECTRONICS CO.,LTD.

**SEMICONDUCTOR
TECHNICAL DATA**

KIA8231L

BIPOLAR LINEAR INTEGRATED CIRCUIT

42W BTL×2CH AUDIO POWER IC

The KIA8231L is BTL audio power amplifier for consumer application. It is designed for high power, low distortion and low noise. It contains various kind of protectors and the function of stand-by.

FEATURES

- High Power
 - : $P_{OUT(1)}=42W(Typ.)$
($V_{CC}=14.4V, f=1kHz, THD=10\%, R_L=2\Omega$)
 - : $P_{OUT(2)}=37W(Typ.)$
($V_{CC}=13.2V, f=1kHz, THD=10\%, R_L=2\Omega$)
 - : $P_{OUT(3)}=22W(Typ.)$
($V_{CC}=13.2V, f=1kHz, THD=10\%, R_L=4\Omega$)
- Excellent Output Power Bandwidth
 - : $P_{OUT(4)}=17W(Typ.)$
($V_{CC}=13.2V, f=20Hz\sim 20kHz, THD=1\%, R_L=4\Omega$)
- Fixed Voltage Gain
 - : $G_v=32dB(Typ.)$
($V_{CC}=13.2V, V_{out}=0.775V_{rms} (0dBm)$)
- Low Thermal Resistance
 - : $\theta_{j-c}=1.5^{\circ}C/W(Typ.)$
- Low Distortion
 - : $THD=0.02\%(Typ.)$
($V_{CC}=13.2V, f=1kHz, P_{out}=4W, R_L=4\Omega$)
- Built-in Stand-by Switch Function
 - : $I_{STBY}=100\mu A(Typ.)$
(With pin ① set at high, power is turned ON)
- Built-in various protection circuit
 - : Thermal shut down, over voltage, out to GND, out to out short
- Operating supply voltage.
 - : $V_{CC(opr)}=9\sim 18V.$

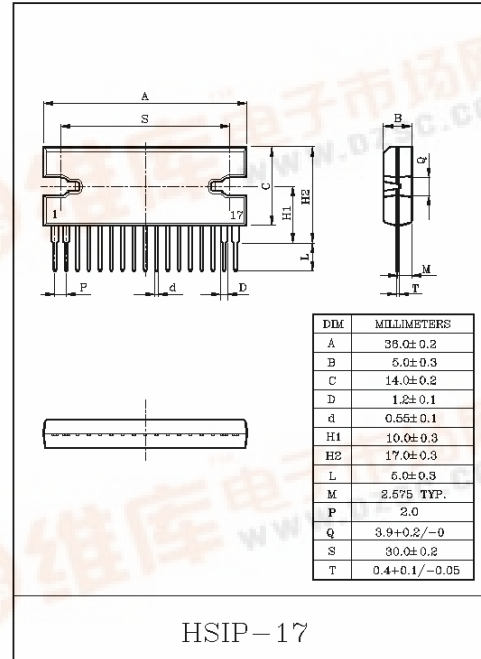

KIA8231L

MAXIMUM RATINGS (Ta=25°C)

CHARACTERISTIC	SYMBOL	RATING	UNIT
Peak Supply Voltage (0.2s)	V _{CC(surge)}	50	V
DC Supply Voltage	V _{CC(DC)}	25	V
Operating Supply Voltage	V _{CC(opr)}	18	V
Output Current (peak)	I _{O(peak)}	9	A
Power Dissipation	P _D	50	W
Operating Temperature	T _{opr}	-30~85	°C
Storage Temperature	T _{stg}	-55~150	°C

ELECTRICAL CHARACTERISTICS

(Unless otherwise specified, V_{CC}=13.2V, R_g=600Ω, R_L=4Ω, f=1kHz, Ta=25°C)

CHARACTERISTIC	SYMBOL	TEST CIRCUIT	TEST CONDITION	MIN.	TYP.	MAX.	UNIT
Quiescent Current	I _{CCQ}	-	V _{IN} =0	-	150	250	mA
Output Power	P _{OUT(1)}	-	V _{CC} =14.4V, THD=10%, R _L =2Ω	-	42	-	W
	P _{OUT(2)}	-	THD=10%, R _L =2Ω	28	37	-	
	P _{OUT(3)}	-	THD=10%, R _L =4Ω	19	22	-	
	P _{OUT(4)}	-	THD=1%, f=20Hz~20kHz, R _L =4Ω	-	17	-	
Total Harmonic Distortion	THD	-	P _{OUT} =4W	-	0.02	0.2	%
Voltage Gain	G _V	-	V _{OUT} =0.775V _{rms} (0dBm)	30.5	32	33.5	dB
Voltage Gain Ratio	ΔG _V	-	V _{OUT} =0.775V _{rms} (0dBm)	-1	0	1	dB
Output Noise Voltage	V _{NO(1)}	-	R _g =0Ω, DIN45405 Noise Filter	-	0.07	-	mV _{rms}
	V _{NO(2)}	-	R _g =0Ω, BW=20Hz~20kHz	-	0.06	0.1	mV _{rms}
Ripple Rejection Ratio	R.R.	-	f _{ripple} =100Hz, R _g =600Ω, V _{OUT} =0.775V _{rms} (0dBm)	40	60	-	dB
Cross Talk	C.T.	-	R _g =600Ω, V _{OUT} =0.775V _{rms} (0dBm)	-	60	-	dB
Input Resistance	R _{IN}	-	-	-	30	-	kΩ
Output Offset Voltage	V _{offset}	-	V _{IN} =0	-200	0	200	mV
Stand-By Current	I _{STBY}	-	Pin① : GND	-	100	150	μA

KIA8231L

BLOCK DIAGRAM

($G_V=32\text{dB}$)

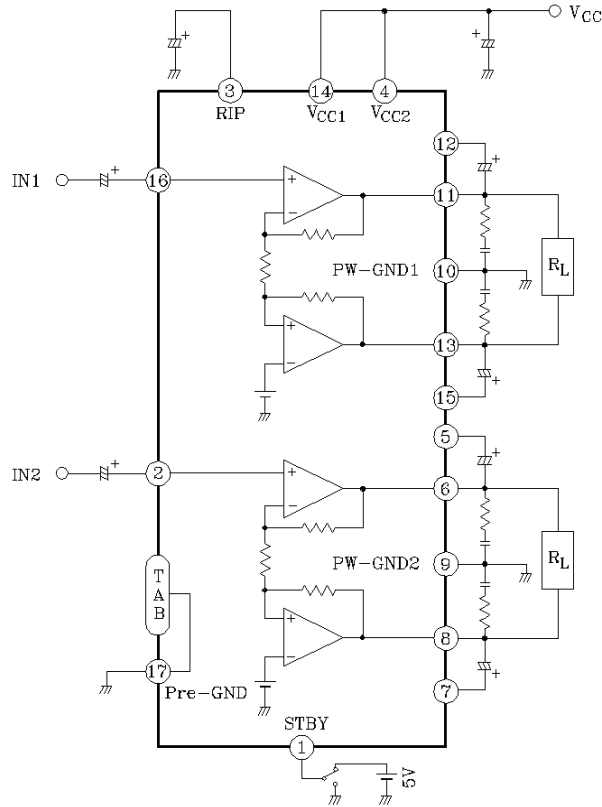

CAUTION AND APPLICATION METHOD

(Description is made only on the single channel.)

1. Voltage gain adjustment

This IC has no NF(negative feedback) terminals. Therefore, the voltage gain can't adjusted, but it makes the device a space and total costs saver.

The voltage gain is decided only internal by expression below.

$$G_V = 20 \log \frac{R_{f1}}{R_{f2}} + 6(\text{dB}) = 32(\text{dB})$$

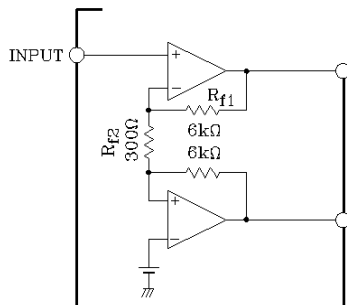

KIA8231L

2. Stand-By SW Function

By means of controlling pin ① (Stand-by terminal) to High and Low, the power supply can be set to ON and OFF. The threshold voltage of pin ① is set at about 3V(Typ.), and the power supply current is about 100μA(Typ.) at the stand-by state.

pin ① control voltage : $V_{(SB)}$

Stand-By	Power	$V_{(SB)}$ (V)
ON	OFF	0 ~ 2
OFF	ON	3 ~ V_{CC}

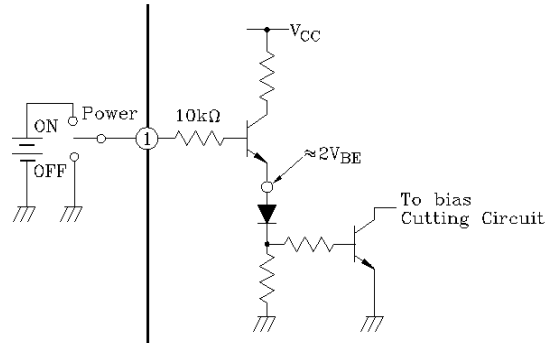

(Fig.2) With pin ① set to High, Power is turned ON.

~ Advantage of Stand-By SW ~

- (1) Since V_{CC} can directly be controlled to ON/OFF by the microcomputer, the switching relay can be omitted.
- (2) Since the control current is microscopic, the switching relay of small current capacity is satisfactory for switching.

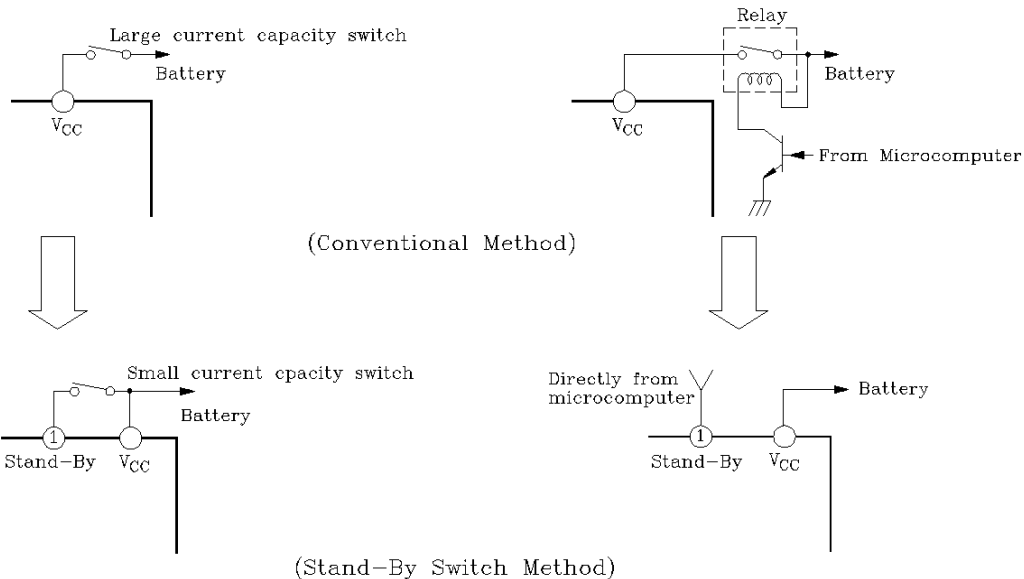

3. Preventive measure against oscillation

For preventing the oscillation, it is advisable to use C4, the condenser of polyester film having small characteristic fluctuation of the temperature and the frequency.

The resistance R to be series applied to C4 is effective for phase correction of high frequency, and improves the oscillation allowance.

Since the oscillation allowance is varied according to the caused described below, perform the temperature test to check the oscillation allowance.

- (1) Capacity value of condenser
- (2) Kind of condenser
- (3) Layout of printed board

KIA8231L

TEST CIRCUIT

($G_V=32\text{dB}$)

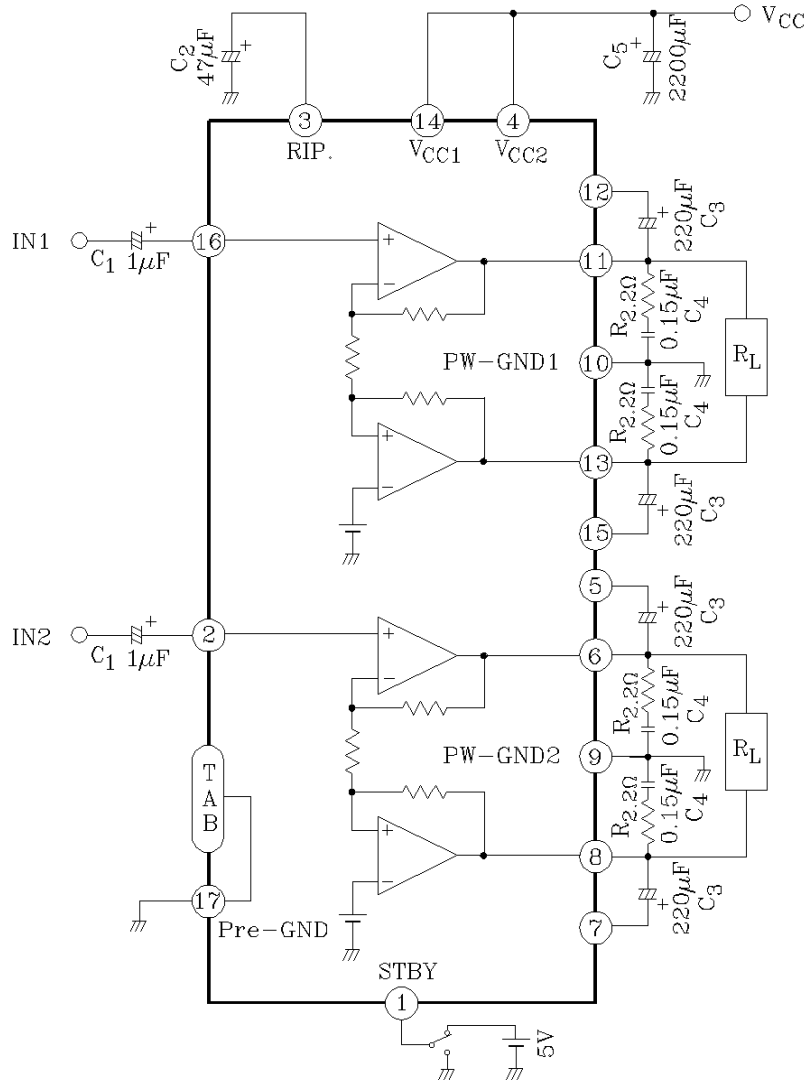

KIA8231L

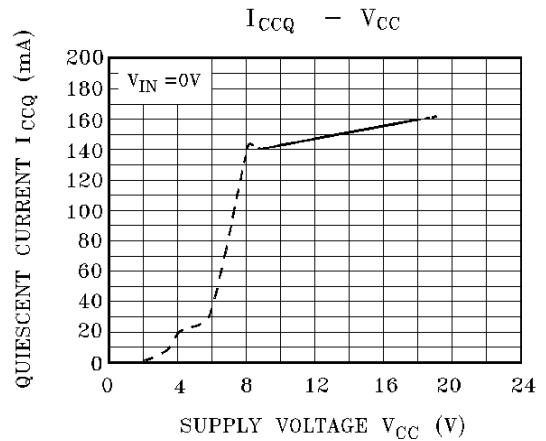
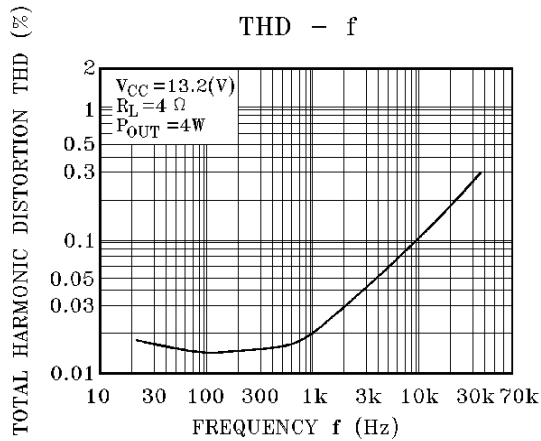
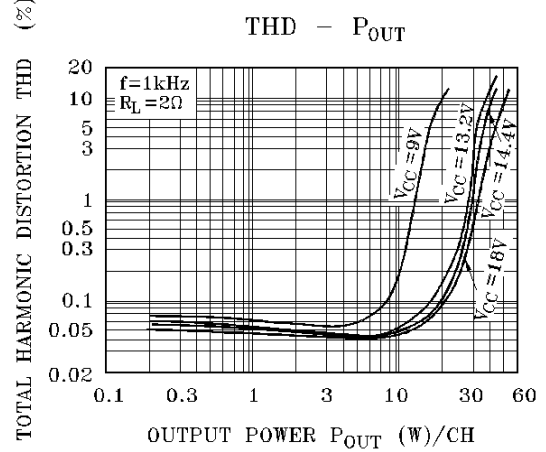
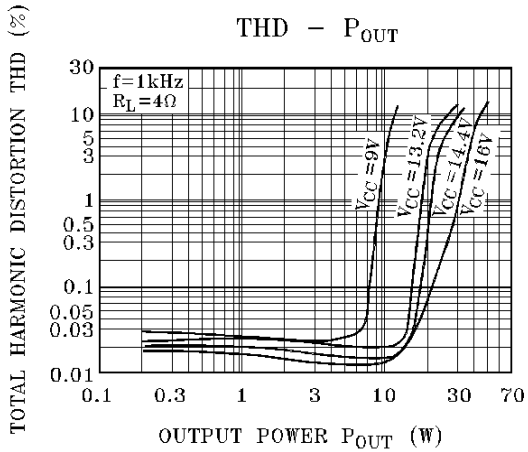
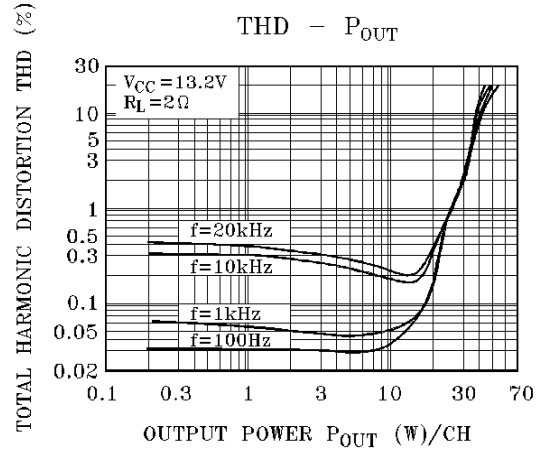
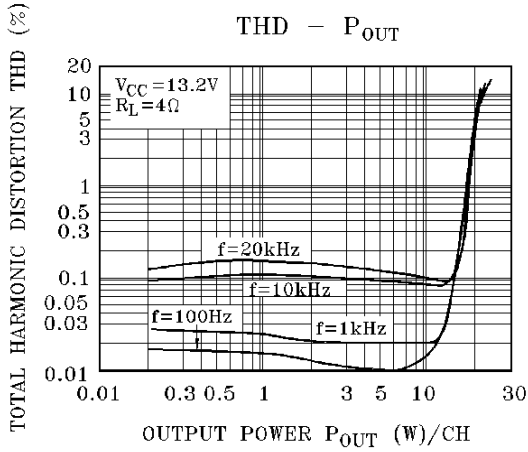

KIA8231L

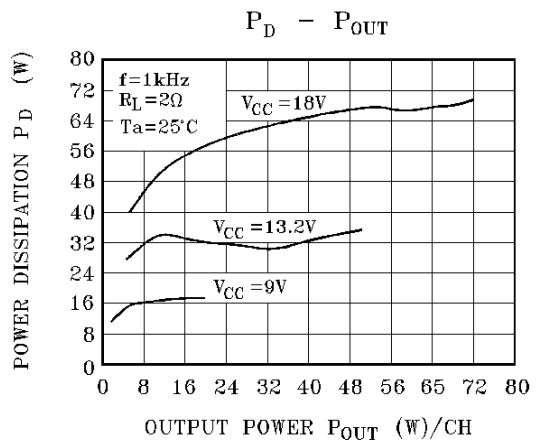
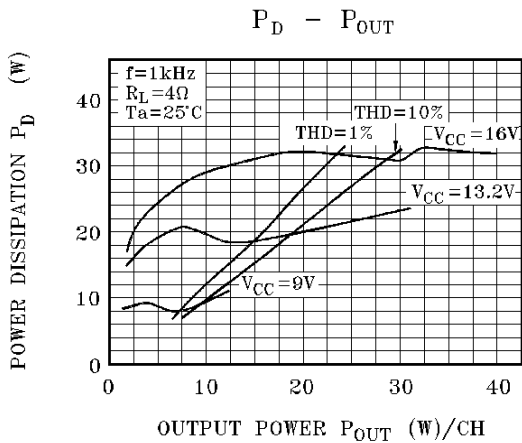
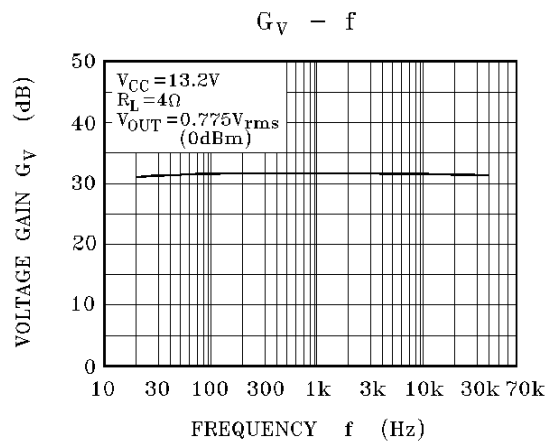
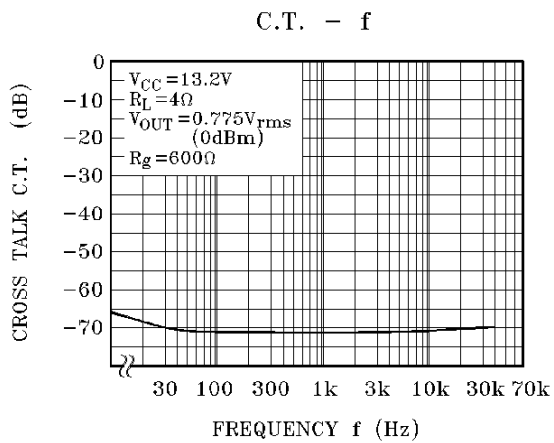
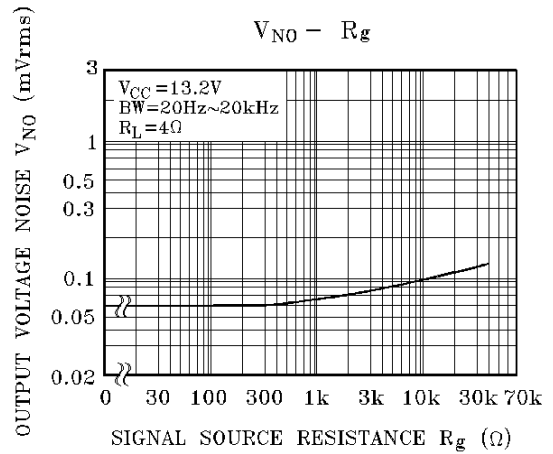
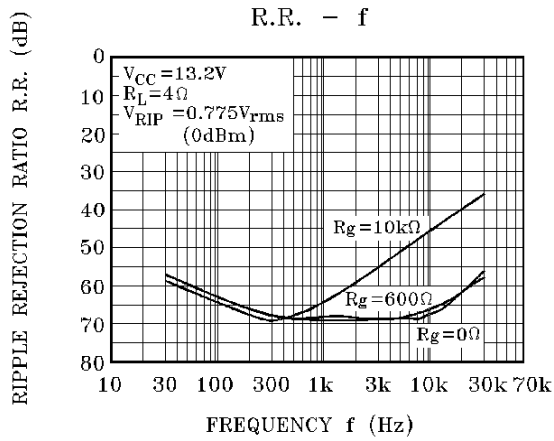

KIA8231L

