



TBB1012

Twin Built in Biasing Circuit MOS FET IC UHF/VHF RF Amplifier

REJ03G1245-0200
Rev.2.00
Aug 22, 2006

Features

- Small SMD package CMPAK-6 built in twin BBFET; To reduce using parts cost & PC board space.
- Very useful for total tuner cost reduction.
- Suitable for World Standard Tuner RF amplifier.
- High gain
- Low noise
- Low output capacitance
- Power supply voltage: 5 V

Outline

RENESAS Package code: PTSP0006JA-A
(Package name: CMPAK-6)

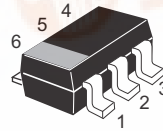

1. Drain(1)
2. Source
3. Drain(2)
4. Gate-1(2)
5. Gate-2
6. Gate-1(1)

- Notes:
1. Marking is "MM".
 2. TBB1012 is individual type number of Renesas TWIN BBFET.

Absolute Maximum Ratings

(Ta = 25°C)

Item	Symbol	Ratings	Unit
Drain to source voltage	V_{DS}	6	V
Gate1 to source voltage	V_{G1S}	+6 -0	V
Gate2 to source voltage	V_{G2S}	+6 -0	V
Drain current	I_D	30	mA
Channel power dissipation	P_{ch} ^{Note3}	250	mW
Channel temperature	T_{ch}	150	°C
Storage temperature	T_{stg}	-55 to +150	°C

Notes: 3. Value on the glass epoxy board (50mm × 40mm × 1mm).



Electrical Characteristics

• FET1

(Ta = 25°C)

Item	Symbol	Min	Typ	Max	Unit	Test Conditions
Drain to source breakdown voltage	$V_{(BR)DSS}$	6	—	—	V	$I_D = 200 \mu A, V_{G1S} = V_{G2S} = 0$
Gate1 to source breakdown voltage	$V_{(BR)G1SS}$	+6	—	—	V	$I_{G1} = +10 \mu A, V_{G2S} = V_{DS} = 0$
Gate2 to source breakdown voltage	$V_{(BR)G2SS}$	+6	—	—	V	$I_{G2} = +10 \mu A, V_{G1S} = V_{DS} = 0$
Gate1 to source cutoff current	I_{G1SS}	—	—	+100	nA	$V_{G1S} = +5 V, V_{G2S} = V_{DS} = 0$
Gate2 to source cutoff current	I_{G2SS}	—	—	+100	nA	$V_{G2S} = +5 V, V_{G1S} = V_{DS} = 0$
Gate1 to source cutoff voltage	$V_{G1S(off)}$	0.5	0.8	1.1	V	$V_{DS} = 5 V, V_{G2S} = 4 V, I_D = 100 \mu A$
Gate2 to source cutoff voltage	$V_{G2S(off)}$	0.4	0.7	1.0	V	$V_{DS} = 5 V, V_{G1S} = 5 V, I_D = 100 \mu A$
Drain current	$I_{D(op)}$	12	16	20	mA	$V_{DS} = 5 V, V_{G1} = 5 V$ $V_{G2S} = 4 V, R_G = 100 k\Omega$
Forward transfer admittance	$ y_{fs} $	27	32	38	mS	$V_{DS} = 5 V, V_{G1} = 5 V, V_{G2S} = 4 V,$ $f = 1 kHz, R_G = 100 k\Omega$
Input capacitance	C_{iss}	1.2	1.6	2.0	pF	$V_{DS} = 5 V, V_{G1} = 5 V, V_{G2S} = 4 V,$ $f = 1 MHz, R_G = 100 k\Omega$
Output capacitance	C_{oss}	0.7	1.1	1.5	pF	$f = 1 MHz, R_G = 100 k\Omega$
Power gain	PG	15	20.5	25	dB	$V_{DS} = 5 V, V_{G1} = 5 V, V_{G2S} = 4 V,$ $R_G = 100 k\Omega, f = 900 MHz$
Noise figure	NF	—	1.95	2.7	dB	$R_G = 100 k\Omega, f = 900 MHz$

• FET2

(Ta = 25°C)

Item	Symbol	Min	Typ	Max	Unit	Test Conditions
Drain to source breakdown voltage	$V_{(BR)DSS}$	6	—	—	V	$I_D = 200 \mu A, V_{G1S} = V_{G2S} = 0$
Gate1 to source breakdown voltage	$V_{(BR)G1SS}$	+6	—	—	V	$I_{G1} = +10 \mu A, V_{G2S} = V_{DS} = 0$
Gate2 to source breakdown voltage	$V_{(BR)G2SS}$	+6	—	—	V	$I_{G2} = +10 \mu A, V_{G1S} = V_{DS} = 0$
Gate1 to source cutoff current	I_{G1SS}	—	—	+100	nA	$V_{G1S} = +5 V, V_{G2S} = V_{DS} = 0$
Gate2 to source cutoff current	I_{G2SS}	—	—	+100	nA	$V_{G2S} = +5 V, V_{G1S} = V_{DS} = 0$
Gate1 to source cutoff voltage	$V_{G1S(off)}$	0.5	0.8	1.1	V	$V_{DS} = 5 V, V_{G2S} = 4 V, I_D = 100 \mu A$
Gate2 to source cutoff voltage	$V_{G2S(off)}$	0.4	0.7	1.0	V	$V_{DS} = 5 V, V_{G1S} = 5 V, I_D = 100 \mu A$
Drain current	$I_{D(op)}$	13	17	21	mA	$V_{DS} = 5 V, V_{G1} = 5 V$ $V_{G2S} = 4 V, R_G = 82 k\Omega$
Forward transfer admittance	$ y_{fs} $	25	30	35	mS	$V_{DS} = 5 V, V_{G1} = 5 V, V_{G2S} = 4 V,$ $f = 1 kHz, R_G = 82 k\Omega$
Input capacitance	C_{iss}	2.3	2.7	3.1	pF	$V_{DS} = 5 V, V_{G1} = 5 V, V_{G2S} = 4 V,$ $f = 1 MHz, R_G = 82 k\Omega$
Output capacitance	C_{oss}	0.9	1.3	1.7	pF	$f = 1 MHz, R_G = 82 k\Omega$
Power gain	PG	24	29.5	34	dB	$V_{DS} = 5 V, V_{G1} = 5 V, V_{G2S} = 4 V,$ $R_G = 82 k\Omega, f = 200 MHz$
Noise figure	NF	—	0.95	1.6	dB	$R_G = 82 k\Omega, f = 200 MHz$

DC Biasing Circuit for Operating Characteristic Items ($I_{D(op)}$, $|y_{fs}|$, C_{iss} , C_{oss} , NF , PG)

• Measurement of FET1

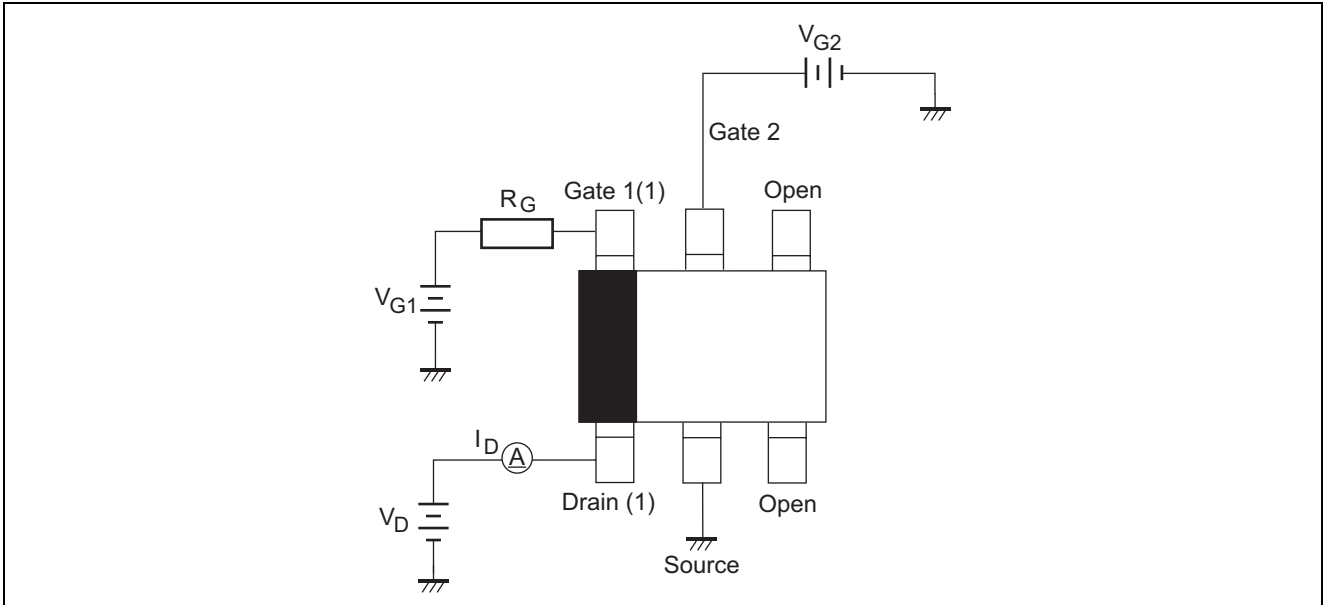

• Measurement of FET2

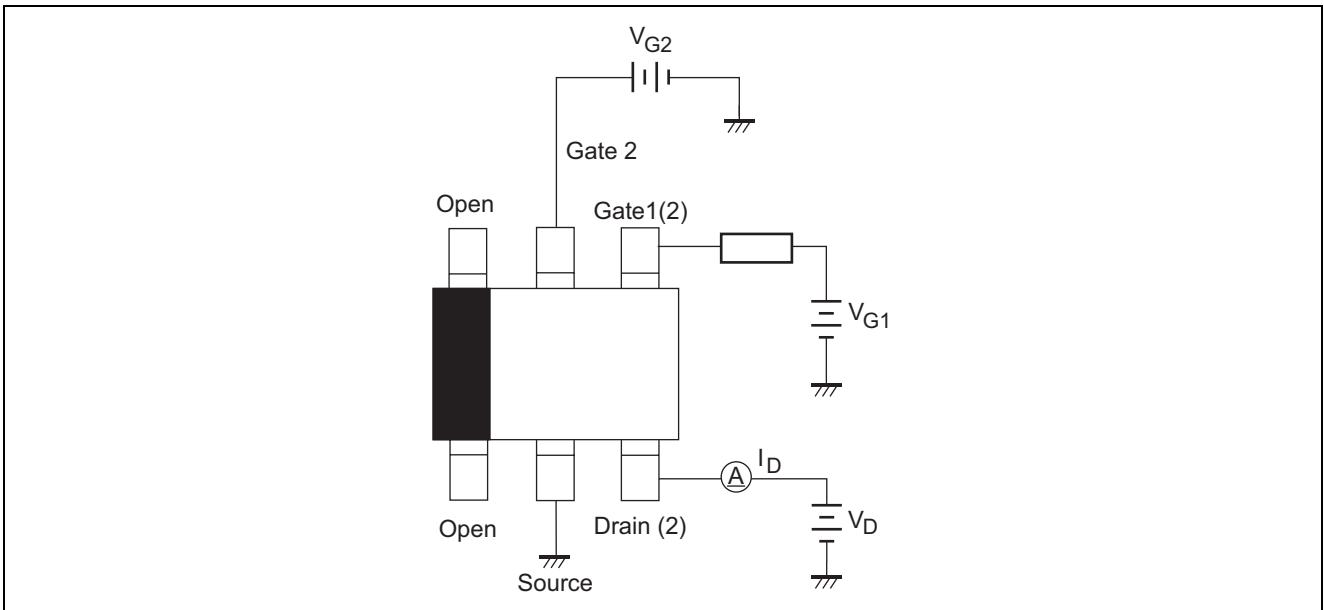

900 MHz Power Gain, Noise Figure Test Circuit

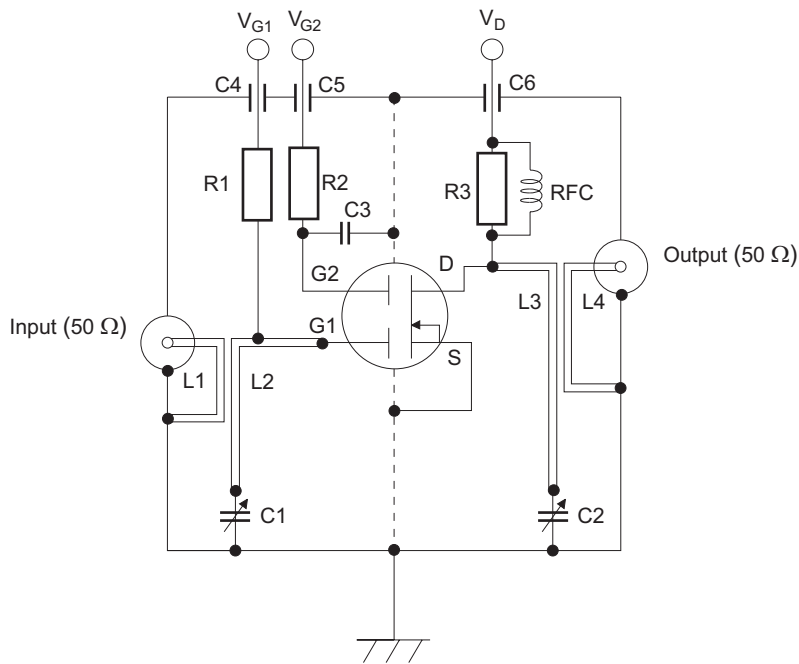

- C1, C2 : Variable Capacitor (10 pF MAX)
- C3 : Disk Capacitor (1000 pF)
- C4 ~ C6 : Air Capacitor (1000 pF)
- R1 : 100 kΩ
- R2 : 47 kΩ
- R3 : 4.7 kΩ

L1:

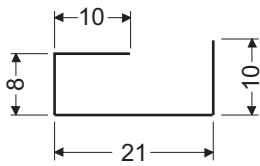

L2:

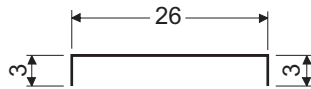

(φ 1 mm Copper wire)
Unit: mm

L3:

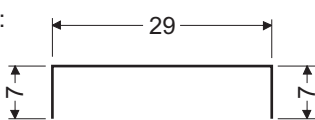

L4:

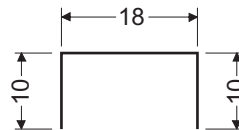

RFC : φ1 mm Copper wire with enamel 4 turns inside dia 6 mm

Main Characteristics

- FET1

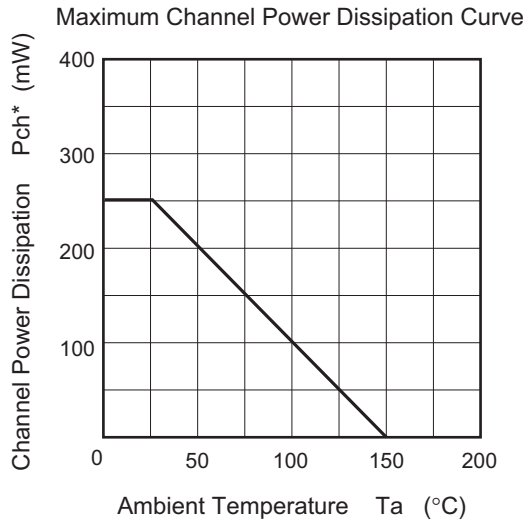

* Value on the glass epoxy board (50 mm × 40 mm × 1 mm)

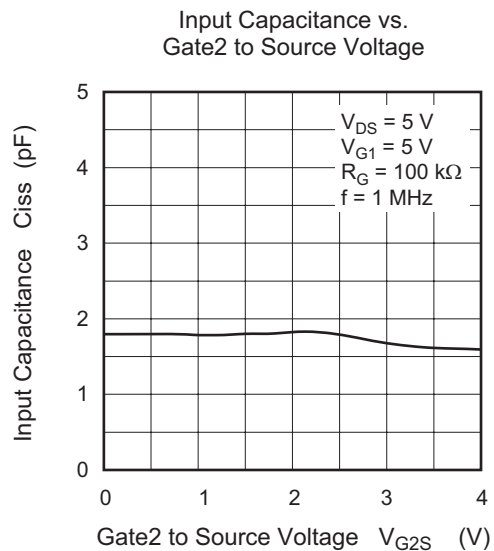
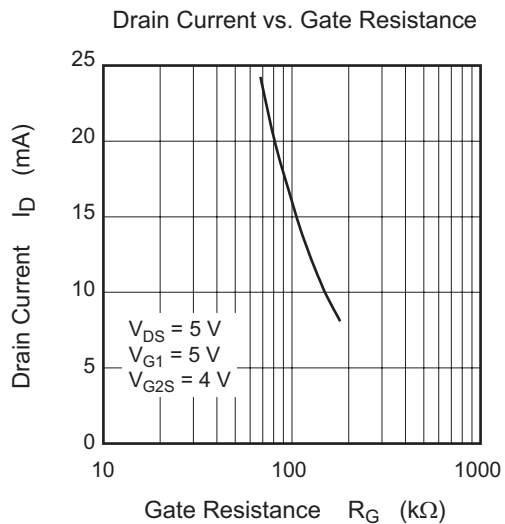
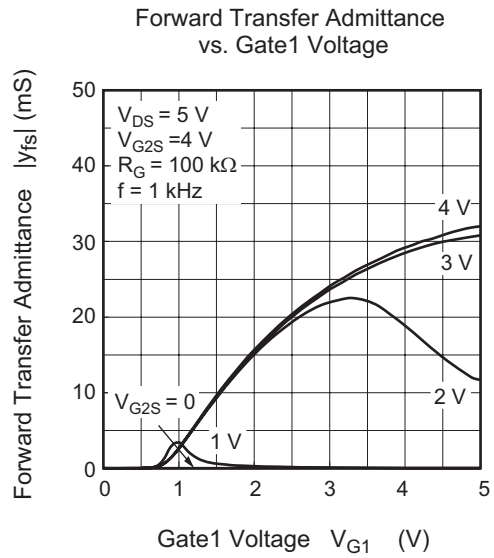
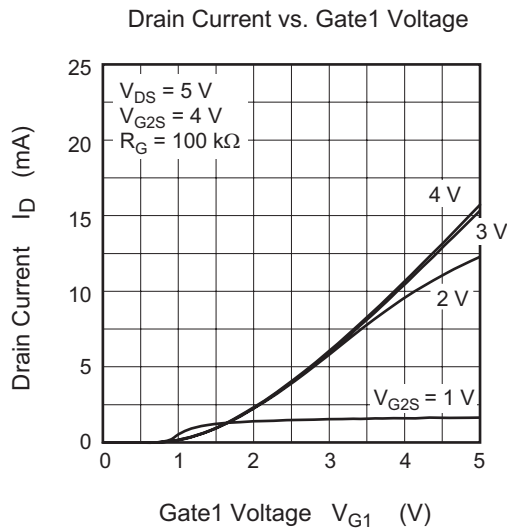
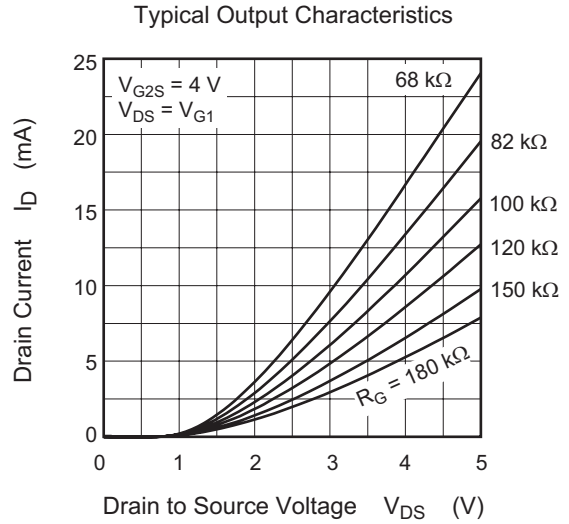

Power Gain vs. Gate Resistance

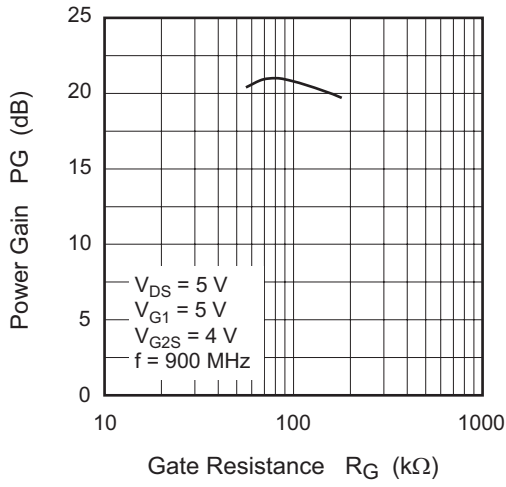

Noise Figure vs. Gate Resistance

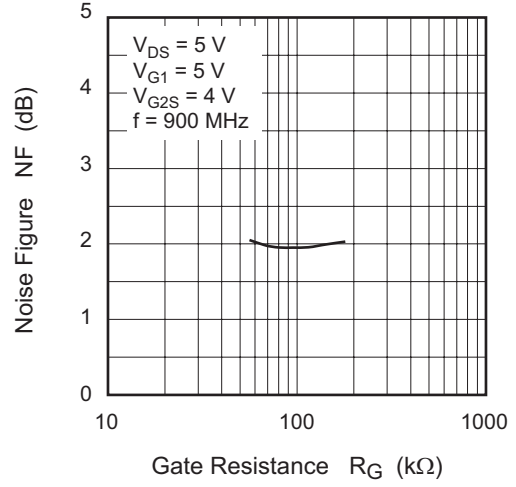

Power Gain vs. Gate2 to Source Voltage

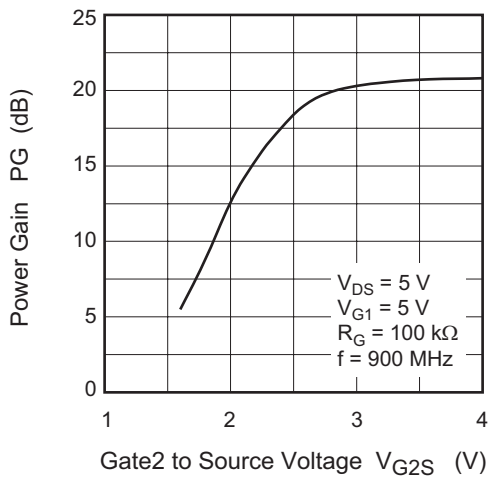

Noise Figure vs. Gate2 to Source Voltage

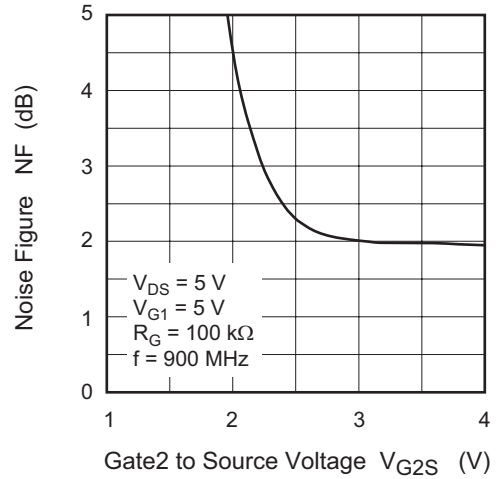

Gain Reduction vs. Gate2 to Source Voltage

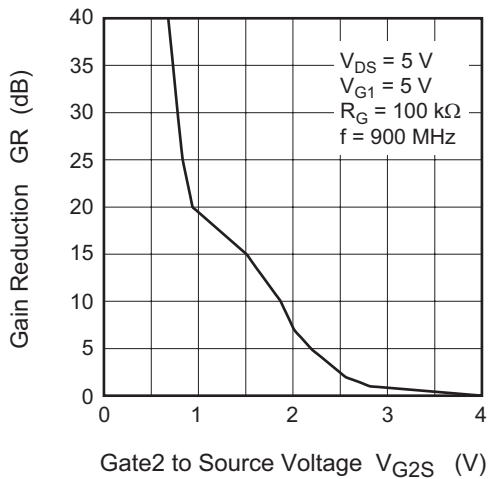

• FET2

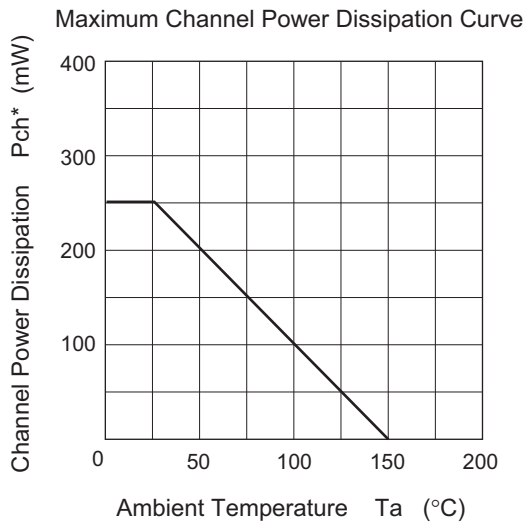

* Value on the glass epoxy board (50 mm × 40 mm × 1 mm)

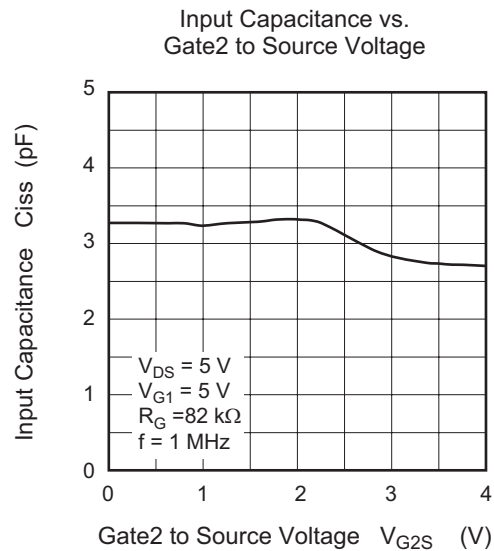
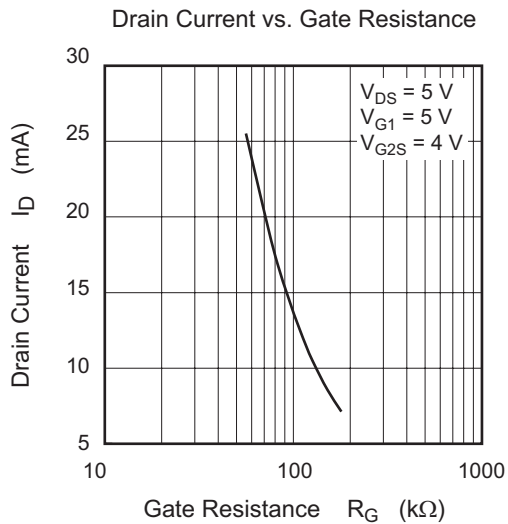
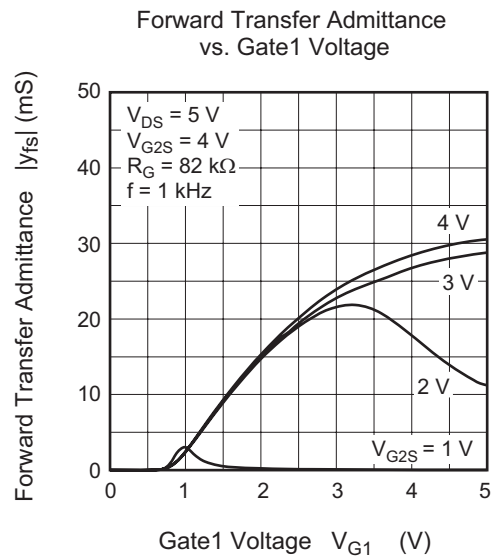
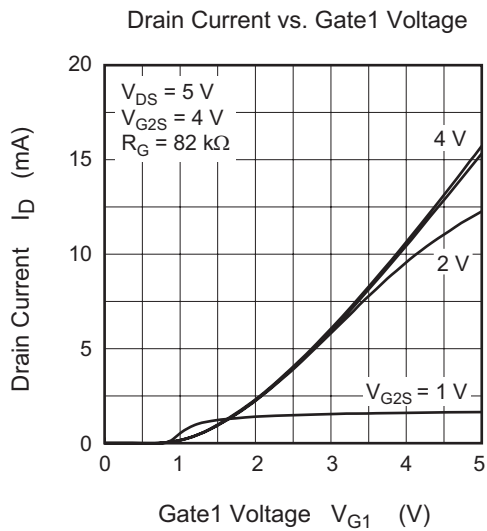
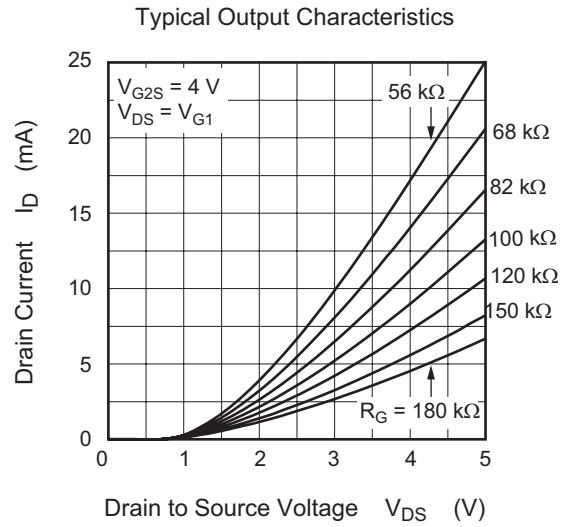

Power Gain vs. Gate Resistance

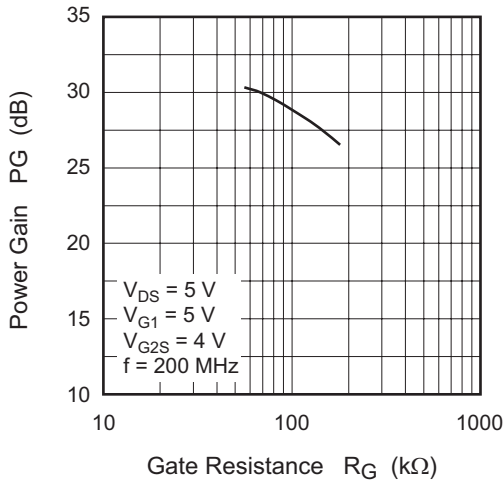

Noise Figure vs. Gate Resistance

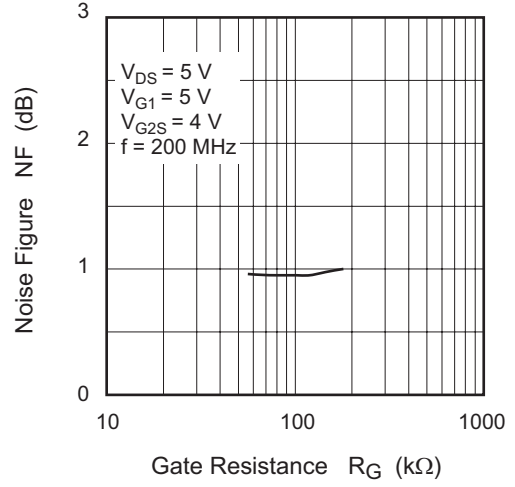

Power Gain vs. Gate2 to Source Voltage

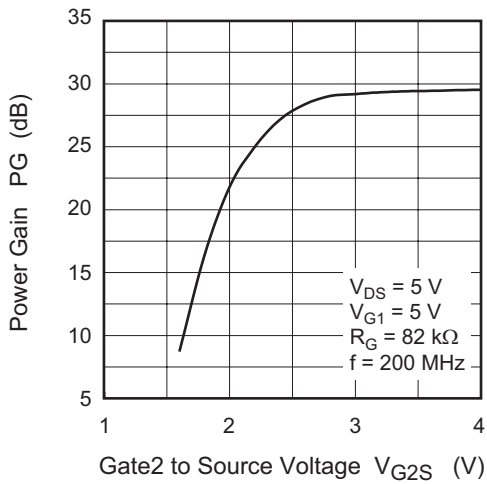

Noise Figure vs. Gate2 to Source Voltage

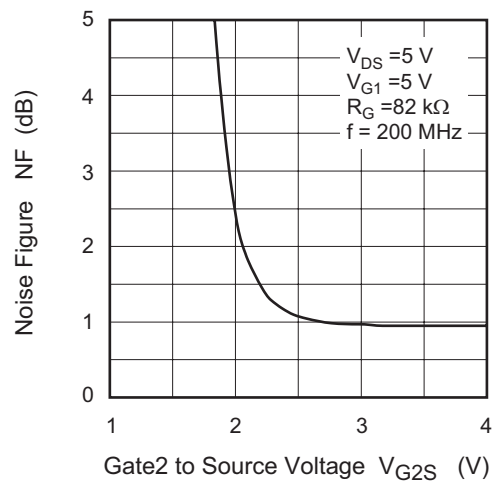

Gain Reduction vs. Gate2 to Source Voltage

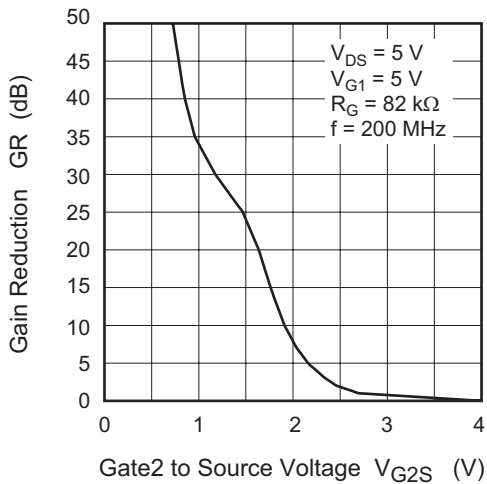

• FET1

S11 Parameter vs. Frequency

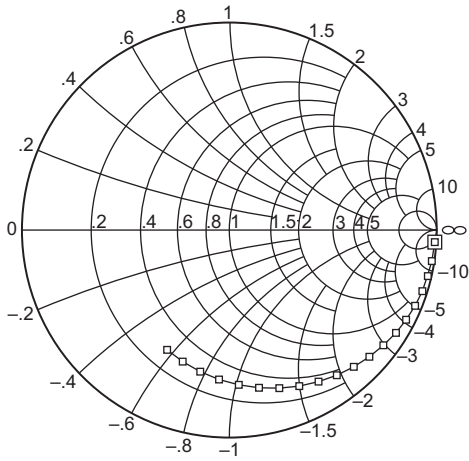

Test condition: $V_{DS} = 5\text{ V}$, $V_{G1} = 5\text{ V}$,
 $V_{G2S} = 4\text{ V}$, $R_G = 100\text{ k}\Omega$
 0.05 to 1.05 GHz (0.05 GHz step)

S21 Parameter vs. Frequency

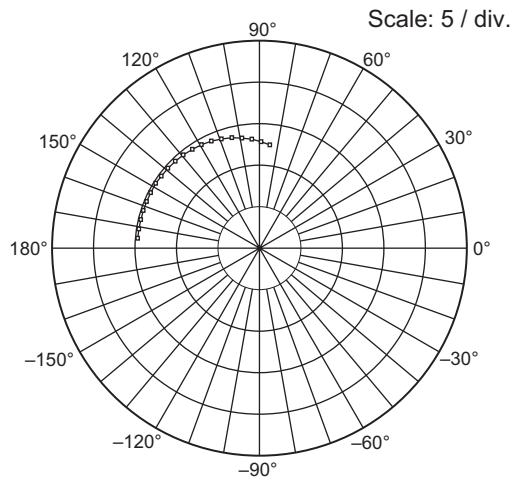

Test condition: $V_{DS} = 5\text{ V}$, $V_{G1} = 5\text{ V}$,
 $V_{G2S} = 4\text{ V}$, $R_G = 100\text{ k}\Omega$
 0.05 to 1.05 GHz (0.05 GHz step)

S12 Parameter vs. Frequency

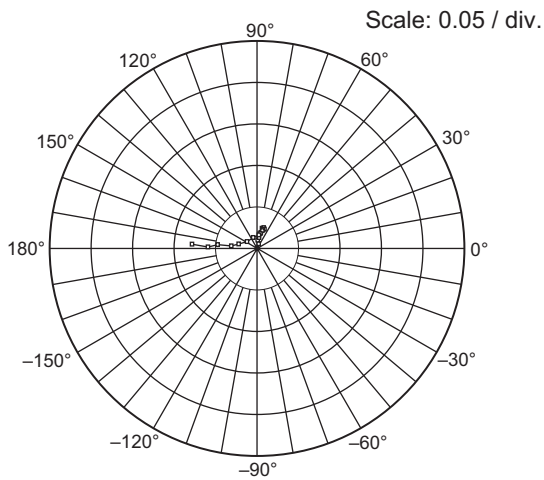

Test condition: $V_{DS} = 5\text{ V}$, $V_{G1} = 5\text{ V}$,
 $V_{G2S} = 4\text{ V}$, $R_G = 100\text{ k}\Omega$
 0.05 to 1.05 GHz (0.05 GHz step)

S22 Parameter vs. Frequency

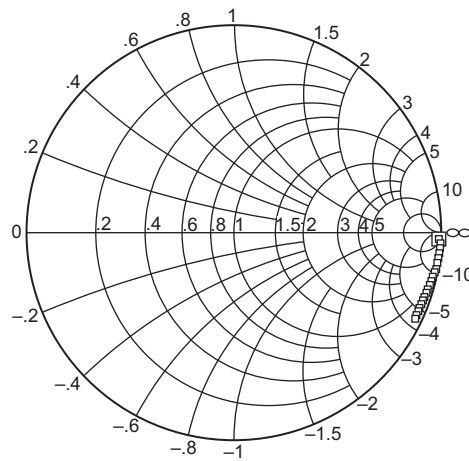

Test condition: $V_{DS} = 5\text{ V}$, $V_{G1} = 5\text{ V}$,
 $V_{G2S} = 4\text{ V}$, $R_G = 100\text{ k}\Omega$
 0.05 to 1.05 GHz (0.05 GHz step)

• FET2

S11 Parameter vs. Frequency

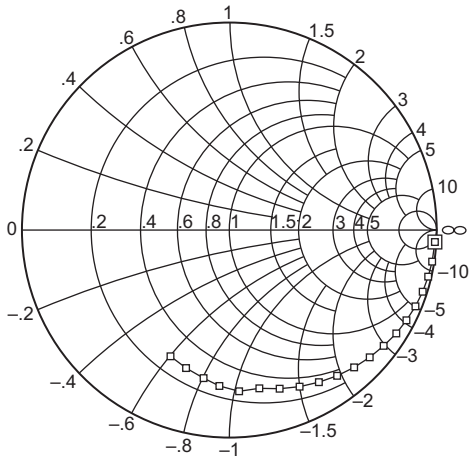

Test condition: $V_{DS} = 5\text{ V}$, $V_{G1} = 5\text{ V}$,
 $V_{G2S} = 4\text{ V}$, $R_G = 82\text{ k}\Omega$
 0.05 to 1.05 GHz (0.05 GHz step)

S21 Parameter vs. Frequency

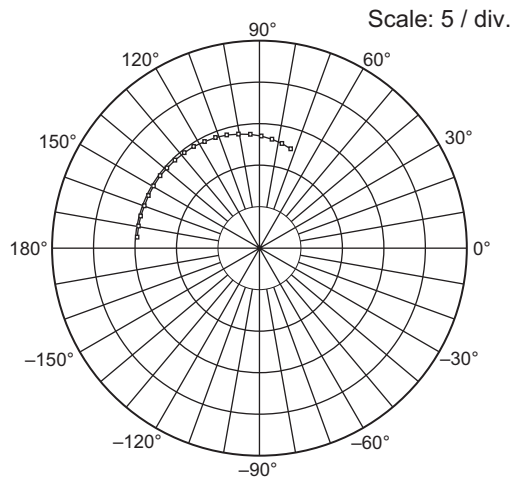

Test condition: $V_{DS} = 5\text{ V}$, $V_{G1} = 5\text{ V}$,
 $V_{G2S} = 4\text{ V}$, $R_G = 82\text{ k}\Omega$
 0.05 to 1.05 GHz (0.05 GHz step)

S12 Parameter vs. Frequency

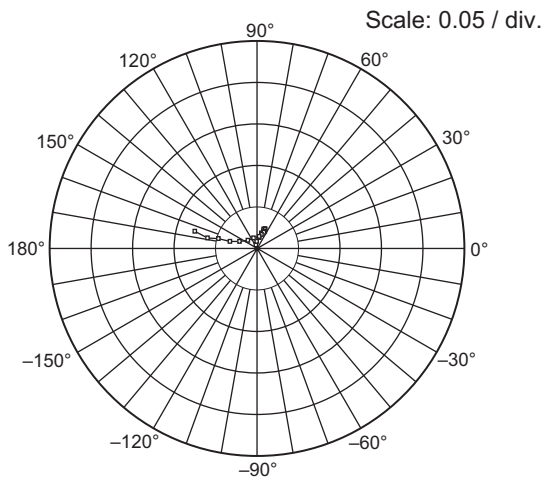

Test condition: $V_{DS} = 5\text{ V}$, $V_{G1} = 5\text{ V}$,
 $V_{G2S} = 4\text{ V}$, $R_G = 82\text{ k}\Omega$
 0.05 to 1.05 GHz (0.05 GHz step)

S22 Parameter vs. Frequency

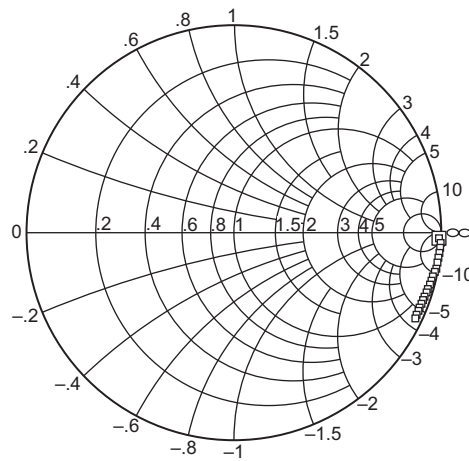

Test condition: $V_{DS} = 5\text{ V}$, $V_{G1} = 5\text{ V}$,
 $V_{G2S} = 4\text{ V}$, $R_G = 82\text{ k}\Omega$
 0.05 to 1.05 GHz (0.05 GHz step)

S parameter

• FET1

($V_{DS} = 5\text{ V}$, $V_{G1} = 5\text{ V}$, $V_{G2S} = 4\text{ V}$, $R_G = 100\text{ k}\Omega$, $Z_o = 50\ \Omega$)

Freq. (MHz)	S11		S21		S12		S22	
	Mag	Deg	Mag	Deg	Mag	Deg	Mag	Deg
50	0.994	-4.3	2.97	175.6	0.001	74.4	0.999	-1.3
100	0.990	-8.8	2.97	171.1	0.002	89.6	0.998	-2.8
150	0.985	-13.1	2.97	166.7	0.002	81.5	0.997	-4.2
200	0.978	-17.6	2.97	162.2	0.003	81.6	0.995	-5.6
250	0.970	-22.2	2.97	157.8	0.004	77.8	0.993	-7.0
300	0.958	-26.9	2.96	153.1	0.005	76.9	0.992	-8.3
350	0.946	-31.7	2.97	148.1	0.005	73.8	0.991	-10.1
400	0.930	-36.8	2.96	143.8	0.005	72.9	0.987	-11.0
450	0.913	-42.1	2.95	139.0	0.005	69.4	0.982	-12.4
500	0.894	-47.7	2.94	134.2	0.004	73.3	0.980	-13.6
550	0.873	-53.4	2.93	129.4	0.004	73.7	0.978	-14.8
600	0.850	-59.5	2.91	124.3	0.003	78.4	0.973	-16.2
650	0.826	-65.8	2.89	119.4	0.003	83.8	0.972	-17.2
700	0.801	-72.4	2.85	114.4	0.003	113.5	0.969	-18.5
750	0.775	-79.2	2.81	109.4	0.003	151.7	0.968	-19.6
800	0.749	-86.4	2.77	104.3	0.005	169.5	0.967	-20.7
850	0.723	-93.8	2.71	99.3	0.006	176.7	0.965	-22.0
900	0.698	-101.4	2.66	94.4	0.010	176.0	0.966	-22.9
950	0.674	-109.3	2.59	89.4	0.012	179.6	0.965	-24.2
1000	0.651	-117.2	2.52	84.7	0.016	177.3	0.967	-25.3

• FET2

($V_{DS} = 5\text{ V}$, $V_{G1} = 5\text{ V}$, $V_{G2S} = 4\text{ V}$, $R_G = 82\text{ k}\Omega$, $Z_o = 50\ \Omega$)

Freq (MHz)	S11		S21		S12		S22	
	Mag	Deg	Mag	Deg	Mag	Deg	Mag	Deg
50	0.986	-4.8	2.96	175.1	0.001	109.6	1.000	-1.9
100	0.983	-10.1	2.96	169.9	0.002	93.5	0.998	-4.0
150	0.979	-14.9	2.96	165.0	0.003	77.5	0.998	-5.9
200	0.971	-20.0	2.95	159.9	0.004	73.2	0.995	-8.0
250	0.963	-25.2	2.96	154.7	0.004	72.4	0.994	-9.9
300	0.951	-30.4	2.96	149.6	0.004	69.1	0.992	-11.9
350	0.937	-35.9	2.96	143.9	0.005	70.2	0.991	-14.2
400	0.923	-41.6	2.95	139.0	0.005	67.3	0.987	-15.7
450	0.905	-47.4	2.95	133.8	0.005	66.2	0.982	-17.7
500	0.887	-53.7	2.93	128.2	0.004	64.6	0.981	-19.5
550	0.868	-60.0	2.92	122.9	0.004	65.8	0.977	-21.4
600	0.843	-66.6	2.90	117.3	0.003	71.3	0.973	-23.3
650	0.821	-73.6	2.88	111.6	0.003	79.4	0.972	-25.0
700	0.796	-80.6	2.85	106.1	0.003	109.7	0.969	-26.9
750	0.769	-88.1	2.80	100.5	0.003	139.9	0.967	-28.6
800	0.744	-95.9	2.76	94.7	0.004	159.6	0.966	-30.3
850	0.719	-103.8	2.71	89.2	0.007	166.6	0.964	-32.2
900	0.692	-112.2	2.65	83.6	0.010	166.5	0.965	-33.7
950	0.669	-120.7	2.58	78.0	0.012	168.6	0.964	-35.6
1000	0.646	-129.1	2.51	72.8	0.015	165.0	0.966	-37.3

Package Dimensions

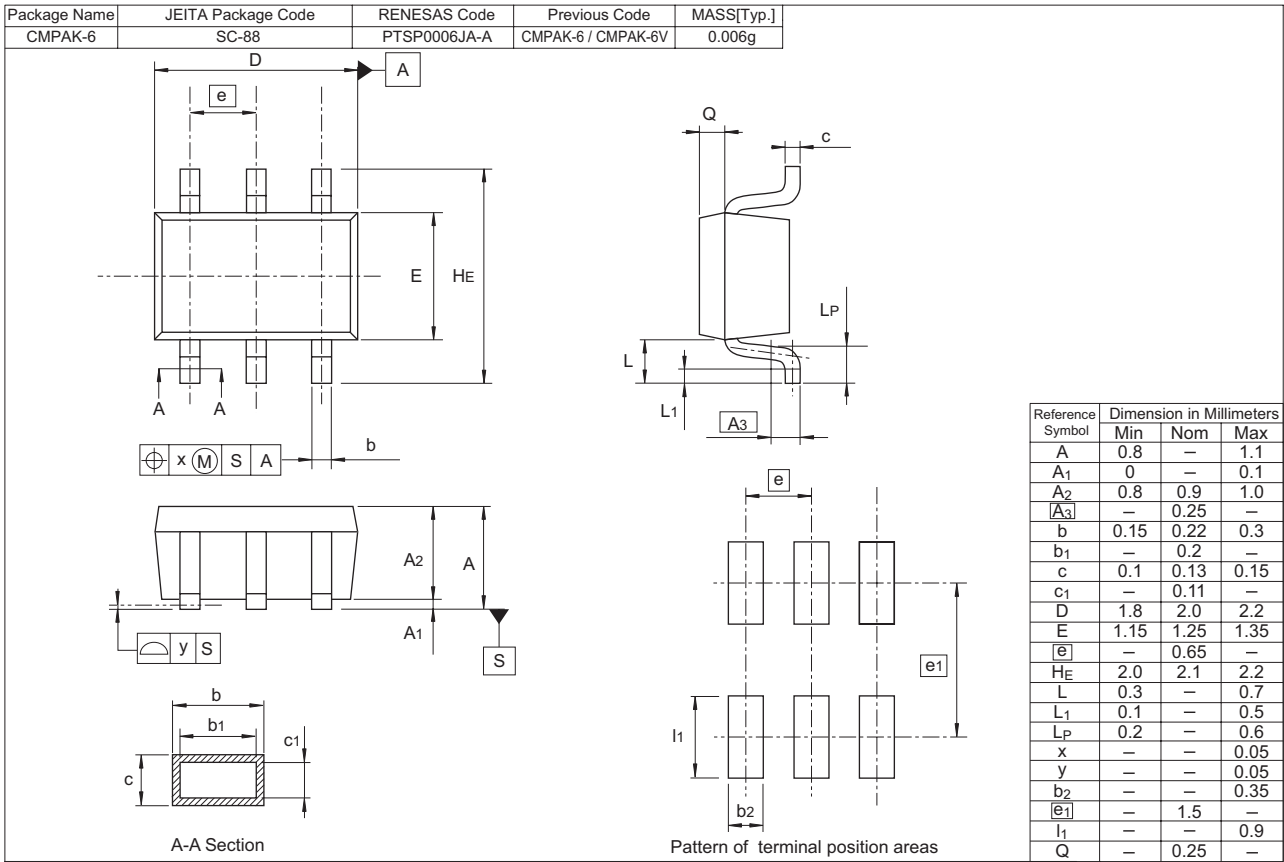

Ordering Information

Part Name	Quantity	Shipping Container
TBB1012MRTL-E	3000 pcs	φ178mm reel, 8mm emboss taping

Note: For some grades, production may be terminated. Please contact the Renesas sales office to check the state of production before ordering the product.

Renesas Technology Corp. Sales Strategic Planning Div. Nippon Bldg., 2-6-2, Ohte-machi, Chiyoda-ku, Tokyo 100-0004, Japan

Keep safety first in your circuit designs!

1. Renesas Technology Corp. puts the maximum effort into making semiconductor products better and more reliable, but there is always the possibility that trouble may occur with them. Trouble with semiconductors may lead to personal injury, fire or property damage. Remember to give due consideration to safety when making your circuit designs, with appropriate measures such as (i) placement of substitutive, auxiliary circuits, (ii) use of nonflammable material or (iii) prevention against any malfunction or mishap.

Notes regarding these materials

1. These materials are intended as a reference to assist our customers in the selection of the Renesas Technology Corp. product best suited to the customer's application; they do not convey any license under any intellectual property rights, or any other rights, belonging to Renesas Technology Corp. or a third party.
2. Renesas Technology Corp. assumes no responsibility for any damage, or infringement of any third-party's rights, originating in the use of any product data, diagrams, charts, programs, algorithms, or circuit application examples contained in these materials.
3. All information contained in these materials, including product data, diagrams, charts, programs and algorithms represents information on products at the time of publication of these materials, and are subject to change by Renesas Technology Corp. without notice due to product improvements or other reasons. It is therefore recommended that customers contact Renesas Technology Corp. or an authorized Renesas Technology Corp. product distributor for the latest product information before purchasing a product listed herein.
The information described here may contain technical inaccuracies or typographical errors.
Renesas Technology Corp. assumes no responsibility for any damage, liability, or other loss rising from these inaccuracies or errors.
Please also pay attention to information published by Renesas Technology Corp. by various means, including the Renesas Technology Corp. Semiconductor home page (<http://www.renesas.com>).
4. When using any or all of the information contained in these materials, including product data, diagrams, charts, programs, and algorithms, please be sure to evaluate all information as a total system before making a final decision on the applicability of the information and products. Renesas Technology Corp. assumes no responsibility for any damage, liability or other loss resulting from the information contained herein.
5. Renesas Technology Corp. semiconductors are not designed or manufactured for use in a device or system that is used under circumstances in which human life is potentially at stake. Please contact Renesas Technology Corp. or an authorized Renesas Technology Corp. product distributor when considering the use of a product contained herein for any specific purposes, such as apparatus or systems for transportation, vehicular, medical, aerospace, nuclear, or undersea repeater use.
6. The prior written approval of Renesas Technology Corp. is necessary to reprint or reproduce in whole or in part these materials.
7. If these products or technologies are subject to the Japanese export control restrictions, they must be exported under a license from the Japanese government and cannot be imported into a country other than the approved destination.
Any diversion or reexport contrary to the export control laws and regulations of Japan and/or the country of destination is prohibited.
8. Please contact Renesas Technology Corp. for further details on these materials or the products contained therein.



RENESAS SALES OFFICES

<http://www.renesas.com>

Refer to "<http://www.renesas.com/en/network>" for the latest and detailed information.

Renesas Technology America, Inc.

450 Holger Way, San Jose, CA 95134-1368, U.S.A
Tel: <1> (408) 382-7500, Fax: <1> (408) 382-7501

Renesas Technology Europe Limited

Dukes Meadow, Millboard Road, Bourne End, Buckinghamshire, SL8 5FH, U.K.
Tel: <44> (1628) 585-100, Fax: <44> (1628) 585-900

Renesas Technology (Shanghai) Co., Ltd.

Unit 204, 205, AZIACenter, No.1233 Lujiazui Ring Rd, Pudong District, Shanghai, China 200120
Tel: <86> (21) 5877-1818, Fax: <86> (21) 6887-7898

Renesas Technology Hong Kong Ltd.

7th Floor, North Tower, World Finance Centre, Harbour City, 1 Canton Road, Tsimshatsui, Kowloon, Hong Kong
Tel: <852> 2265-6688, Fax: <852> 2730-6071

Renesas Technology Taiwan Co., Ltd.

10th Floor, No.99, Fushing North Road, Taipei, Taiwan
Tel: <886> (2) 2715-2888, Fax: <886> (2) 2713-2999

Renesas Technology Singapore Pte. Ltd.

1 Harbour Front Avenue, #06-10, Keppel Bay Tower, Singapore 098632
Tel: <65> 6213-0200, Fax: <65> 6278-8001

Renesas Technology Korea Co., Ltd.

Kukje Center Bldg. 18th Fl., 191, 2-ka, Hangang-ro, Yongsan-ku, Seoul 140-702, Korea
Tel: <82> (2) 796-3115, Fax: <82> (2) 796-2145

Renesas Technology Malaysia Sdn. Bhd

Unit 906, Block B, Menara Amcorp, Amcorp Trade Centre, No.18, Jalan Persiaran Barat, 46050 Petaling Jaya, Selangor Darul Ehsan, Malaysia
Tel: <603> 7955-9390, Fax: <603> 7955-9510