

**TOSHIBA**

Tentative

**TB62750FTG**

TOSHIBA BiCD Digital Integrated Circuit Silicon Monolithic

**TB62750FTG**

Step Up Type DC-DC Converter for White LED

TB62750FTG is the high efficient STEP-UP type DC/DC converter by which the optimal design was carried out at constant current driver of white LED. It is possible to drive white LEDs whose constant output current is 800mA by the lithium ion battery. This IC contains the Nch-MOS transistor required for switching of external inductor. The forward current of LED is set up by the external resistor. This IC is the most suitable as a driver of camera flashes and strobes in the cellular phone, the PDA, the DSC, and other mobiles.

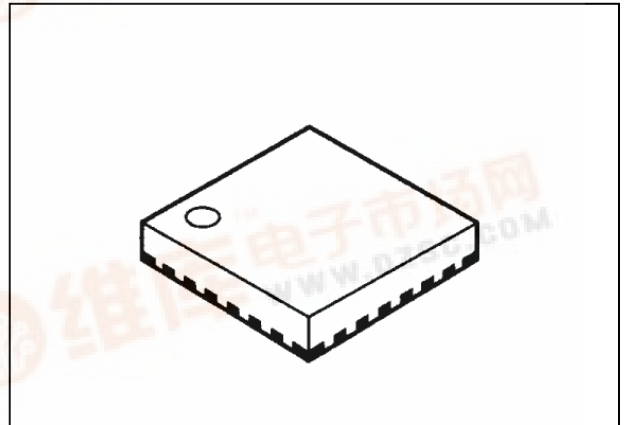

(VQON24-0404-0.65)

Weight : 0.09g (Typ.)

現品表示 ;

■ Features

- Switching terminal current : 1.8A(Typ.)
- Maximum output power :
- Maximum output voltage : 10V
- Operating frequency : 2MHz
- Four operating modes
- Light mode :ILED=350mA(Typ.) (R3=8.2kΩ, R2=62kΩ)
- Flash mode :ILED=800mA(Typ.) (RSENS=0.375Ω)
- Shutdown mode :Icc=0.01μA(Typ.)
- High efficiency :Maximum efficiency : 80%(In the flash mode)

Application

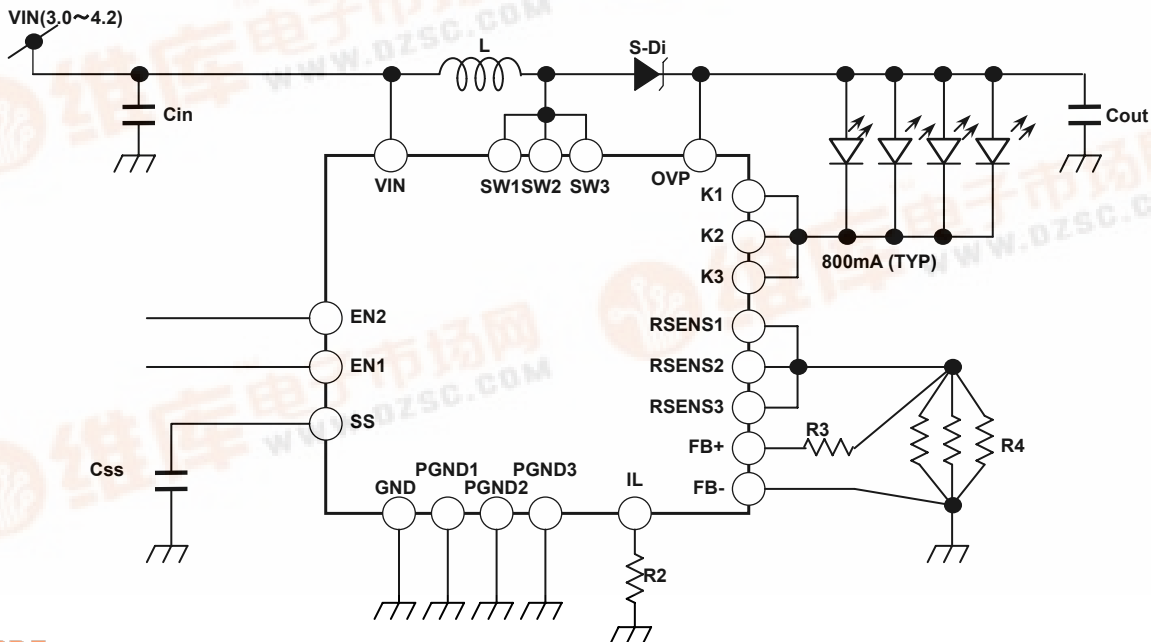

■ Pin Assignment (top view)

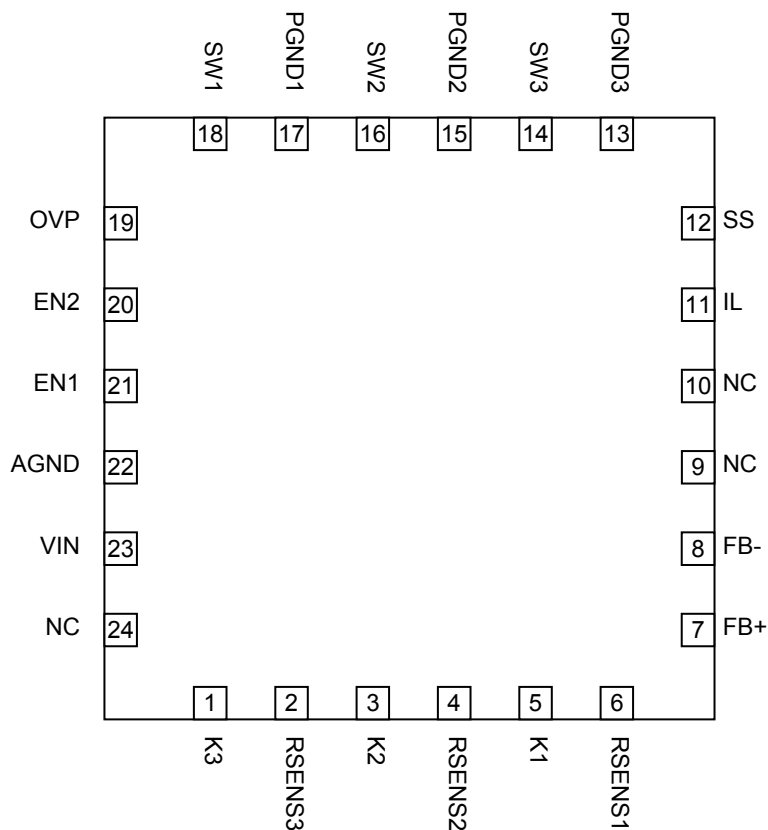

■ Block Diagram

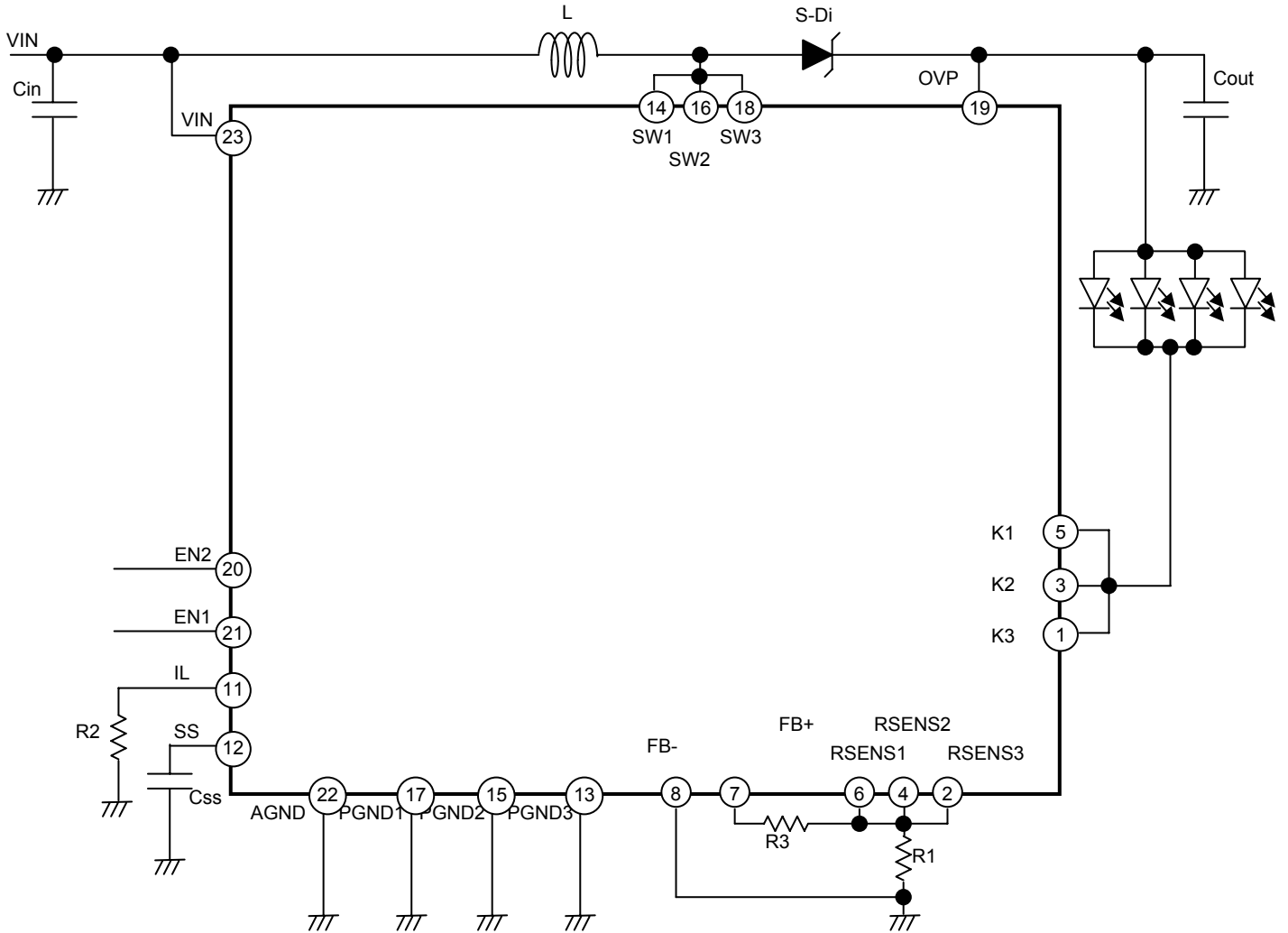

## ■ Explanation of the Terminal

No.	Symbol	Function
1	K3	Connected to the LED cathode.
2	RSENS3	Connected to the current-setting resistor: R1 for the flash.
3	K2	Connected to the LED cathode.
4	RSENS2	Connected to the current-setting resistor: R1 for the flash.
5	K1	Connected to the LED cathode.
6	RSENS1	Connected to the current-setting resistor: R1 for the flash.
7	FB+	Detecting the voltage of the current-setting resistor: R1 for the flash. It can change the light-mode-current with the resistor: R3 which is connected to FB+.
8	FB-	
9	NC	No Connect
10	NC	No Connect
11	IL	Connected to the ILED setting resistor: R2 in the light mode. The light-mode-current is changed depending on the setting ratio of R2 and R3.
12	SS	Setting the constant to limit the current when DC-DC operation starts. The rising time is changed depending on the constant of the condenser.
13	PGND3	Ground terminal for the power device.
14	SW3	Switching the DC-DC converter. Nch MOSFET is built-in.
15	PGND2	Ground terminal for the power device.
16	SW2	Switching the DC-DC converter. Nch MOSFET is built-in.
17	PGND1	Ground terminal for the power device.
18	SW1	Switching the DC-DC converter. Nch MOSFET is built-in.
19	OVP	Detecting the over-voltage.
20	EN2	Inputting the logic signals which set the modes. "ON" :Flash mode "OFF" :Lighting mode
21	EN1	Inputting the logic signals which set the modes. "ON" :DC-DC operation "OFF" :Stop
22	AGND	Ground terminal for analog.
23	VIN	Inputting the power supply voltage to the IC. The operating voltage is 2.8 to 5.5V.
24	NC	No Connect

### ■ Absolute Maximum Ratings (T<sub>opr</sub> = 25°C if not specified)

Characteristics	Symbol	Ratings	Unit
Power supply voltage	VCC	- 0.3 ~ 6.0	V
Input voltage	Vin	- 0.3 ~ VIN + 0.3	V
Switching terminal voltage	Vo(SW)	- 0.3 ~ 12	V
Output current	Iout	1000	mA
Operating temperature range	Topr	- 40 ~ 85	°C
Storage temperature	Tstg	- 55 ~ 150	°C

### ■ Recommended Operating Condition (T<sub>opr</sub> = -40 to 85°C if not specified)

Characteristics		Symbol	Test Conditions	Min.	Typ.	Max.	Unit
Power supply voltage		VIN	-	2.8	-	5.5	V
Logic Input Voltage	HIGH	VIH	EN1,EN2	0.7XVIN	-	VIN +0.15	V
	LOW	VIL		-0.15	-	0.3X VIN	
Constant-current output		Iout	-	-	800	1000	mA
ISET Resistor	Flash mode	R1	-	-	0.375	-	Ω
	Light mode	R2	-	51	62	75	kΩ
		R3	-	-	8.2	-	kΩ
Input condenser		Cin	-	-	20	-	μF
Output condenser		Cout	-	-	10	-	μF
Condenser for soft start		Css	-	2200	3300	10000	pF
External inductor		L	-	-	3.9	-	μH

**■ Electrical Characteristics (T<sub>opr</sub> = -40~85°C V<sub>CC</sub> = 2.8~5.5 V if not specified.)**
**Characteristics of DC-DC regulator. (T<sub>opr</sub> = -40~85°C, V<sub>IN</sub> = 2.8~5.5V if not specified)**

Characteristics	Symbol	Test Conditions	Min.	Typ.	Max.	Unit
Power supply voltage	V <sub>IN</sub>	-	2.8	-	5.5	V
Operating consumption current	I <sub>IN(On)</sub>	EN1="H", EN2="L" V <sub>in</sub> =3.6V, R2=62kΩ R3=8.2kΩ, R1=0.375Ω	-	TBD	-	mA
Quiescent consumption current	I <sub>IN(Off)</sub>	EN1="L", EN2="L" V <sub>in</sub> =3.6V	-	0.01	0.5	μA
Input current (Logic input terminal)	I <sub>INEN1</sub> I <sub>INEN2</sub>	V <sub>in</sub> =3.6V	-	-	0.5	μA
Integrated MOS-Tr switching frequency	f <sub>osc</sub>	V <sub>in</sub> =3.6V	1.6	2	2.4	MHz
SW terminal protection voltage	V <sub>o(SW)</sub>	-	-	12	-	V
Switching terminal current	I <sub>o(SW)</sub>	-	-	1.8	-	A
Switching terminal leakage current	I <sub>oz(SW)</sub>	-	-	0.5	1	μA
FB terminal feedback voltage	V <sub>FB</sub>	EN1="H", EN2="H" V <sub>in</sub> =3.6V, R1=0.375Ω T <sub>opr</sub> =25°C	285	300	315	mV
		EN1="H", EN2="L" V <sub>in</sub> =3.6V, R1=0.375Ω R2 = 62kΩ, R3 = 8.2kΩ T <sub>opr</sub> =25°C	TBD	130	TBD	mV
FB terminal line regulation	ΔV <sub>FB</sub>	V <sub>in</sub> =3.6V (typ.) V <sub>in</sub> =3.0~4.2V	-	2	-	%
OVD voltage (OVD terminal)	V <sub>OVD</sub>	-	-	10.7	-	V
TSD			120	157	180	°C

## Characteristics of constant-current of SINK(Topr = 25°C, Vcc = 3.6V if not specified.)

Characteristics	Symbol	Test Conditions	Min.	Typ.	Max.	Unit
ISET output current (Light mode)	ISET	EN1 = "H" EN2 = "L" R2= 62kΩ, R3= 8.2kΩ R1 = 0.375Ω	-	20	-	μA
ISET output voltage (Light mode)	VISET	EN1 = "H" EN2 = "L" R2= 62kΩ	-	TBD	-	V
Lighting time in flash mode	t FLASH	Tolerance time under EN2 = "H" and EN1 = "H". R1 = 0.375Ω	-	100	300	ms

■ **Explanation of operation**

**【Setting the operating mode】**

1. Selecting the four modes shown below with logic input terminals: EN1 and EN2.

EN1	EN2	MODE
L	L	Shutdown mode
L	H	
H	L	Light mode
H	H	Flash mode

• Flash mode

It can be driven with the constant-current at 800mA (max.). The maximum lightning time is 300ms. Because it controls the FB+ at 300mV, the equation shown below is obtained.

$$I_{out}(mA) = 300(mV) \div R1(\Omega)$$

Pay attentions to the differences of the connected resistors and the power consumption.

The recommended resistor is as follows;

- Three or more resistors (1/4 W) in parallel.

• Light mode

It can light continually by driving at constant-current (350mA in max.).

It sets the current of K1 to K3 based on the resistors: R1, R2, and R3.

$$I_{out} (mA) = \frac{0.3V - \left( 1.2V \text{ (Internal Vref)} \times \frac{R3}{R2} \right)}{R1}$$

The current value of IL is recommended at about 20 μA.

Set R2 at 51kΩ to 75kΩ.

When R3 is set at 0Ω, the same current is set in the flash mode and the light mode.

• Shutdown mode

It stops the operation.



**【Setting the input condenser】**

TBD

**【Setting the output condenser】**

TBD

**【Setting the external inductor】**

Operating frequency : 2MHz

The circuit operation has the consecutive mode method. The ability of the output current is changed by the constant of the inductor.

**【Soft start function】**

This function is built-in to avoid the over-inserting current and the power drop when the flash mode and the light mode switch.

When the condenser (Approximately 3300pF) is connected to the SS terminal, the rising time becomes about 300  $\mu$ s in the flash mode.

**【OVD function】**

OVP voltage: Detecting the over-load at 10.7V(TYP).

When the loaded voltage of OVP rises because of the LED opening or something other, this function shutdowns the IC.

The operation recovers just after the voltage of OVP falls to 10.7V or less.

**【TSD function】**

MAX 180°C

MIN 120°C

**SOLDERABILITY**

The following conditions apply to solderability.

- Solderability

- (1) Use of Sn-63Pb solder bath

- solder bath temperature = 230°C, dipping time = 5 seconds, number of times = once, use of R-type flux

- (2) Use of Sn-3.0Ag-0.5Cu solder bath

**CAUTION**

- Particular care is necessary in the design of the output, VCC, COMMON and GND lines since the IC may be destroyed by short circuits between outputs, air contamination faults, or faults arising from improper grounding.
- Do not insert devices in the wrong orientation. Make sure that the positive and negative terminals of power supplies are connected correctly. Otherwise the rated maximum current or power dissipation may be exceeded and the device may break down or undergo performance degradation, causing it to catch fire or explode and resulting in injury.
- Note that the IC may be destroyed as a result of damage to or misconnection of external components.

**RESTRICTIONS ON PRODUCT USE**

030619EBA

- The information contained herein is subject to change without notice.
- The information contained herein is presented only as a guide for the applications of our products. No responsibility is assumed by TOSHIBA for any infringements of patents or other rights of the third parties which may result from its use. No license is granted by implication or otherwise under any patent or patent rights of TOSHIBA or others.
- TOSHIBA is continually working to improve the quality and reliability of its products. Nevertheless, semiconductor devices in general can malfunction or fail due to their inherent electrical sensitivity and vulnerability to physical stress. It is the responsibility of the buyer, when utilizing TOSHIBA products, to comply with the standards of safety in making a safe design for the entire system, and to avoid situations in which a malfunction or failure of such TOSHIBA products could cause loss of human life, bodily injury or damage to property.  
In developing your designs, please ensure that TOSHIBA products are used within specified operating ranges as set forth in the most recent TOSHIBA products specifications. Also, please keep in mind the precautions and conditions set forth in the "Handling Guide for Semiconductor Devices," or "TOSHIBA Semiconductor Reliability Handbook" etc..
- The TOSHIBA products listed in this document are intended for usage in general electronics applications (computer, personal equipment, office equipment, measuring equipment, industrial robotics, domestic appliances, etc.). These TOSHIBA products are neither intended nor warranted for usage in equipment that requires extraordinarily high quality and/or reliability or a malfunction or failure of which may cause loss of human life or bodily injury ("Unintended Usage"). Unintended Usage include atomic energy control instruments, airplane or spaceship instruments, transportation instruments, traffic signal instruments, combustion control instruments, medical instruments, all types of safety devices, etc.. Unintended Usage of TOSHIBA products listed in this document shall be made at the customer's own risk.
- The products described in this document are subject to the foreign exchange and foreign trade laws.
- TOSHIBA products should not be embedded to the downstream products which are prohibited to be produced and sold, under any law and regulations.