

**Preliminary**

TOSHIBA Bi-CMOS Integrated Circuit Silicon Monolithic

# TB6562ANG

## Dual Full-Bridge Driver IC for Stepping Motors

The TB6562ANG is a 2-phase bipolar stepping motor driver that contains DMOS transistors in the output stage. The driver achieves high efficiency through the use of low ON-resistance DMOS transistors and PWM current control circuitry.

### Features

- 2-phase/1-2 phase/W 1-2 phase excitation
- PWM current control
- Power supply voltage: 40 V (max)
- Output current: 1.5 A (max)
- Low ON-resistance: 1.5  $\Omega$  (upper and lower transistors/typ.)
- Power-saving function
- Overcurrent protection:  $I_{lim}=2.5$  A (typ.)
- Thermal shutdown
- Package: SDIP24-P-300-1.78

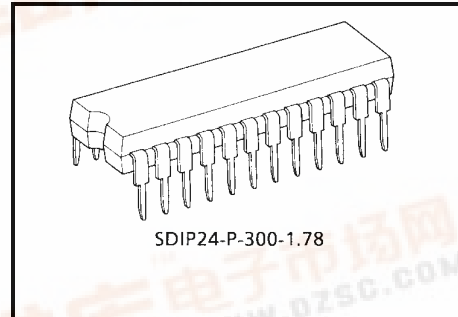

SDIP24-P-300-1.78

Weight: 1.62 g (typ.)

### TB6562ANG:

TB6562ANG is Pb-free product.

The following conditions apply to solderability:

#### \*Solderability

1. Use of Sn-63Pb solder bath
  - \*solder bath temperature = 230°C
  - \*dipping time = 5 seconds
  - \*number of times = once
  - \*use of R-type flux
2. Use of Sn-3.0Ag-0.5Cu solder bath
  - \*solder bath temperature = 245°C
  - \*dipping time = 5 seconds
  - \*number of times = once
  - \*use of R-type flux

**Block Diagram**

Some functional blocks, circuits, or constants may be omitted or simplified in the block diagram for explanatory purposes.

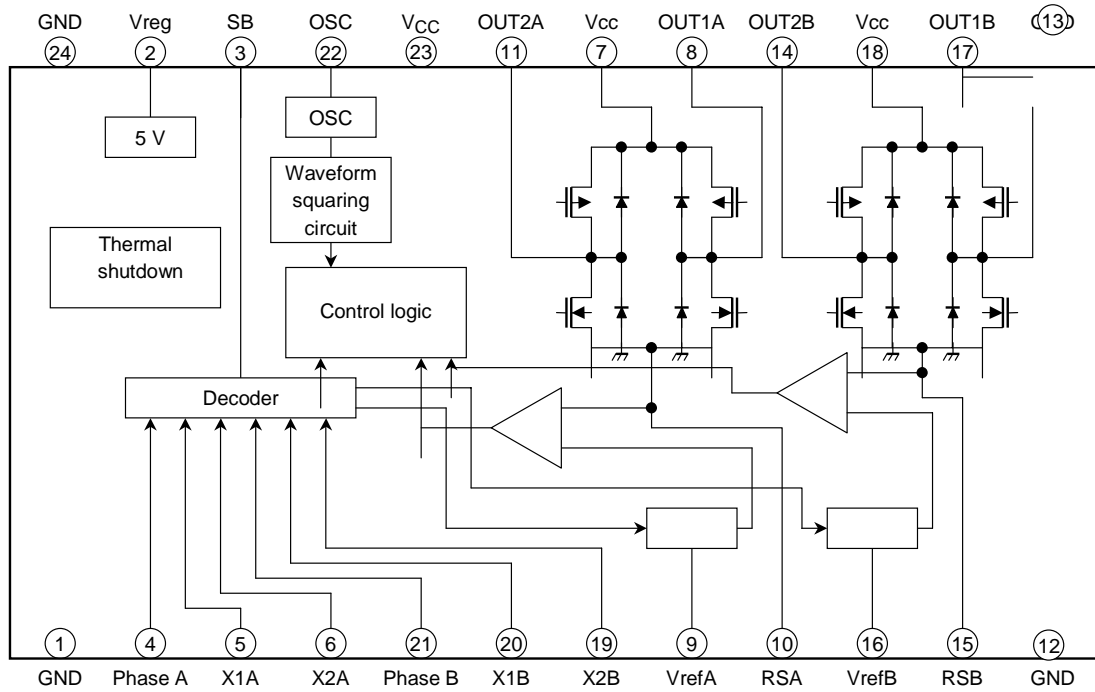

**Maximum Ratings (Ta = 25°C)**

Characteristics	Symbol	Rating	Unit
Power supply voltage	V <sub>CC</sub>	40	V
Output voltage	V <sub>o</sub>	40	V
Output current	I <sub>O (Peak)</sub>	1.5	A
Input voltage	V <sub>in</sub>	5.5	V
Power dissipation	P <sub>D</sub>	2.5 (Note 1)	W
Operating temperature	T <sub>opr</sub>	-20 to 85	°C
Storage temperature	T <sub>stg</sub>	-55 to 150	°C
Junction temperature	T <sub>jmax</sub>	150	°C

Note 1: When mounted on a board (50 mm × 50 mm × 1.6 mm, Cu area: 50%)

The absolute maximum ratings of a semiconductor device are a set of specified parameter values that must not be exceeded during operation, even for an instant.

If any of these ratings are exceeded during operation, the electrical characteristics of the device may be irreparably altered, in which case the reliability and lifetime of the device can no longer be guaranteed.

Moreover, any exceeding of the ratings during operation may cause breakdown, damage and/or degradation in other equipment. Applications using the device should be designed so that no maximum rating will ever be exceeded under any operating condition.

Before using, creating and/or producing designs, refer to and comply with the precautions and conditions set forth in this document.

**Operating Range (Ta = 25°C)**

Characteristics	Symbol	Rating	Unit
Power supply voltage	V <sub>CC</sub>	10~ 34	V
Input voltage	V <sub>in</sub>	0~ 5	V
Vref voltage	V <sub>ref</sub>	0.5~ 7.0	V
PWM frequency	f <sub>pwm</sub>	15~ 80	kHz
Triangular-wave oscillation frequency	f <sub>osc</sub>	45~ 400	kHz

**Pin Description**

Pin No.	Symbol	Function Description	Remarks
1	GND	Ground pin	
2	Vreg	5-V output pin	Connect a capacitor between this pin and GND pin.
3	SB	Standby pin	HIGH: Start, LOW: Standby
4	Phase A	Rotation direction control pin (ch. A)	Apply a 0-V/5-V signal.
5	X1A	Input pin used to set output current level (ch. A)	Apply a 0-V/5-V signal.
6	X2A	Input pin used to set output current level (ch. A)	Apply a 0-V/5-V signal.
7	V <sub>CC</sub>	Power supply voltage input pin	V <sub>CC (opr)</sub> = 10 V to 34 V
8	OUT1A	Output pin 1 (ch. A)	Connect to a motor coil pin.
9	VrefA	Input pin for external reference voltage (ch. A)	
10	RSA	Output current detection resistor connection pin (ch. A)	
11	OUT2A	Output pin 2 (ch. A)	Connect to a motor coil pin.
12	GND	Ground pin	
13	GND	Ground pin	
14	OUT2B	Output pin 2 (ch. B)	Connect to a motor coil pin.
15	RSB	Output current detection resistor connection pin (ch. B)	
16	VrefB	Power supply voltage input pin for motor drive (ch. B)	
17	OUT1B	Output pin 1 (ch. B)	Connect to a motor coil pin.
18	V <sub>CC</sub>	Power supply voltage input pin	V <sub>CC (opr)</sub> = 10 V to 34 V
19	X2B	Input pin used to set output current level (ch. B)	Apply a 0-V/5-V signal.
20	X1B	Input pin used to set output current level (ch. B)	Apply a 0-V/5-V signal.
21	Phase B	Rotation direction control pin (ch. B)	Apply a 0-V/5-V signal.
22	OSC	Capacitor connection pin for triangular-wave oscillation	
23	V <sub>CC</sub>	Power supply voltage input pin	V <sub>CC (opr)</sub> = 10 V to 34 V
24	GND	Ground pin	

**Electrical Characteristics (V<sub>CC</sub> = 24 V, Ta = 25°C)**

Characteristics		Symbol	Test Circuit	Test Condition	Min	Typ.	Max	Unit
Supply current		ICC1	—	XT1A = XT2A = H, XT1B = XT2B = H	—	6.5	10	mA
		ICC2		XT1A = XT2A = L, XT1B = XT2B = L	—	7.0	12	
		ICC3		Standby mode	—	2.0	4.0	
Control circuit (Note 1)	Input voltage	V <sub>INH</sub>	—	—	2	—	5.5	V
		V <sub>INL</sub>		—	-0.2	—	0.8	
	Input hysteresis voltage	V <sub>IN (HYS)</sub>	—	—	—	0.4	—	μA
	Input current	I <sub>INH</sub>	—	V <sub>IN</sub> = 5 V	30	50	75	
		I <sub>INL</sub>	—	V <sub>IN</sub> = 0 V	—	—	5	
Standby circuit	Input voltage	V <sub>INSH</sub>	—	—	2	—	5.5	V
		V <sub>INSL</sub>		—	-0.2	—	0.8	
	Input hysteresis voltage	V <sub>IN (HYS)</sub>	—	—	—	0.4	—	μA
	Input current	I <sub>INSH</sub>	—	V <sub>IN</sub> = 5 V	30	50	75	
		I <sub>INSL</sub>	—	V <sub>IN</sub> = 0 V	—	—	5	
Output ON-resistance		R <sub>on (U + L)</sub>	—	I <sub>O</sub> = 1.5 A	—	1.5	2.0	Ω
				I <sub>O</sub> = 1.5 A	—	1.5	2.0	
Output leakage current		I <sub>L (U)</sub>	—	V <sub>CC</sub> = 40 V	—	—	10	μA
		I <sub>L (L)</sub>		V <sub>CC</sub> = 40 V	—	—	10	
Diode forward voltage		V <sub>F (U)</sub>	—	I <sub>O</sub> = 1.5 A	—	1.3	2.0	V
		V <sub>F (L)</sub>		I <sub>O</sub> = 1.5 A	—	1.3	2.0	
Internal reference voltage		V <sub>reg</sub>	—	1 mA	4.75	5	5.25	V
V <sub>ref</sub> circuit	Input current	I <sub>ref</sub>	—	V <sub>ref</sub> = 0.5 V	—	5	10	μA
	Current limit voltage	V <sub>ref (1/10)</sub>	—	X1 = X2 = L V <sub>ref</sub> = 5 V	0.45	0.5	0.55	V
		V <sub>ref (1/15)</sub>	—	X1 = L, X2 = H V <sub>ref</sub> = 5 V	0.28	0.33	0.38	
		V <sub>ref (1/30)</sub>	—	X1 = H, X2 = L V <sub>ref</sub> = 5 V	0.12	0.17	0.22	
Triangular-wave oscillation frequency		f <sub>osc</sub>	—	C = 4700 pF	88	110	132	kHz
Thermal shutdown circuit operating temperature		T <sub>SD</sub>	—		—	160	—	°C

Note 1: Phase, X1 and X2 pins

## Truth Tables

< 2-phase excitation >

Phase A				Phase B			
Input			Output	Input			Output
Phase A	X1A	X2A	I <sub>O</sub> (A)	Phase B	X1B	X2B	I <sub>O</sub> (B)
H	L	L	100%	H	L	L	100%
L	L	L	-100%	H	L	L	100%
L	L	L	-100%	L	L	L	-100%
H	L	L	100%	L	L	L	-100%

< 1-2 phase excitation >

Phase A				Phase B			
Input			Output	Input			Output
Phase A	X1A	X2A	I <sub>O</sub> (A)	Phase B	X1B	X2B	I <sub>O</sub> (B)
H	L	L	100%	H	L	L	100%
X	H	H	0%	H	L	L	100%
L	L	L	-100%	H	L	L	100%
L	L	L	-100%	X	H	H	0%
L	L	L	-100%	L	L	L	-100%
X	H	H	0%	L	L	L	-100%
H	L	L	100%	L	L	L	-100%
H	L	L	100%	X	H	H	0%

< W1-2 phase excitation >

Phase A				Phase B			
Input			Output	Input			Output
Phase A	X1A	X2A	I <sub>O</sub> (A)	Phase B	X1B	X2B	I <sub>O</sub> (B)
X	H	H	0%	L	L	L	-100%
H	H	L	33.3%	L	L	L	-100%
H	L	H	66.7%	L	L	H	-66.7%
H	L	L	100%	L	H	L	-33.3%
H	L	L	100%	X	H	H	0%
H	L	L	100%	H	H	L	33.3%
H	H	L	33.3%	H	L	H	66.7%
H	L	H	66.7%	H	L	L	100%
X	H	H	0%	H	L	L	100%
L	H	L	-33.3%	H	L	L	100%
L	L	H	-66.7%	H	L	H	66.7%
L	L	L	-100%	H	H	L	33.3%
L	L	L	-100%	X	H	H	0%
L	L	L	-100%	L	H	L	-33.3%
L	L	H	-66.7%	L	L	H	-66.7%
L	H	L	-33.3%	L	L	L	-100%

## Timing Charts

Timing charts may be simplified for explanatory purposes.

< 2-phase excitation >

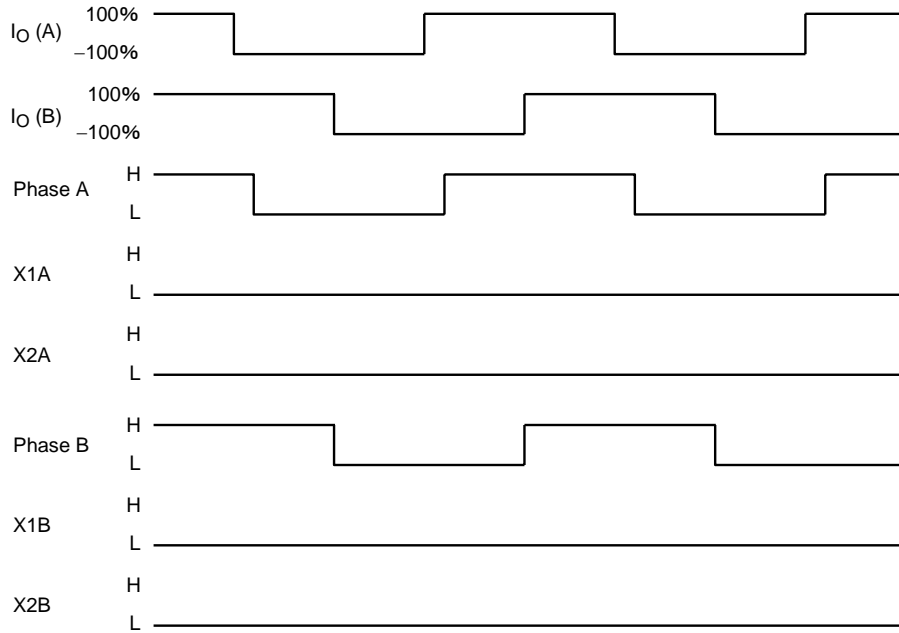

< 1-2 phase excitation >

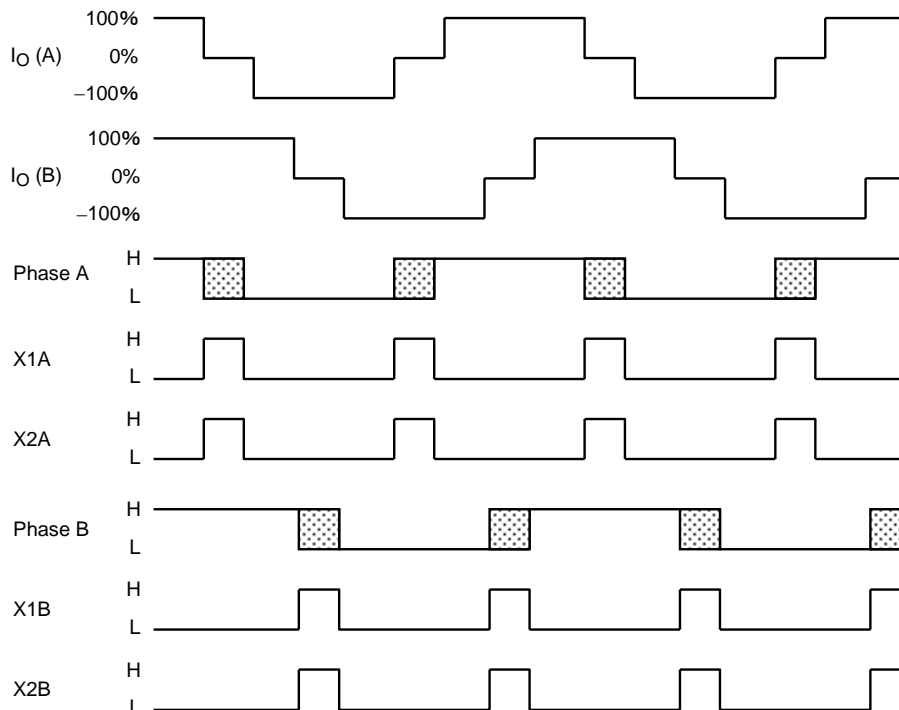

< W1-2 phase excitation >

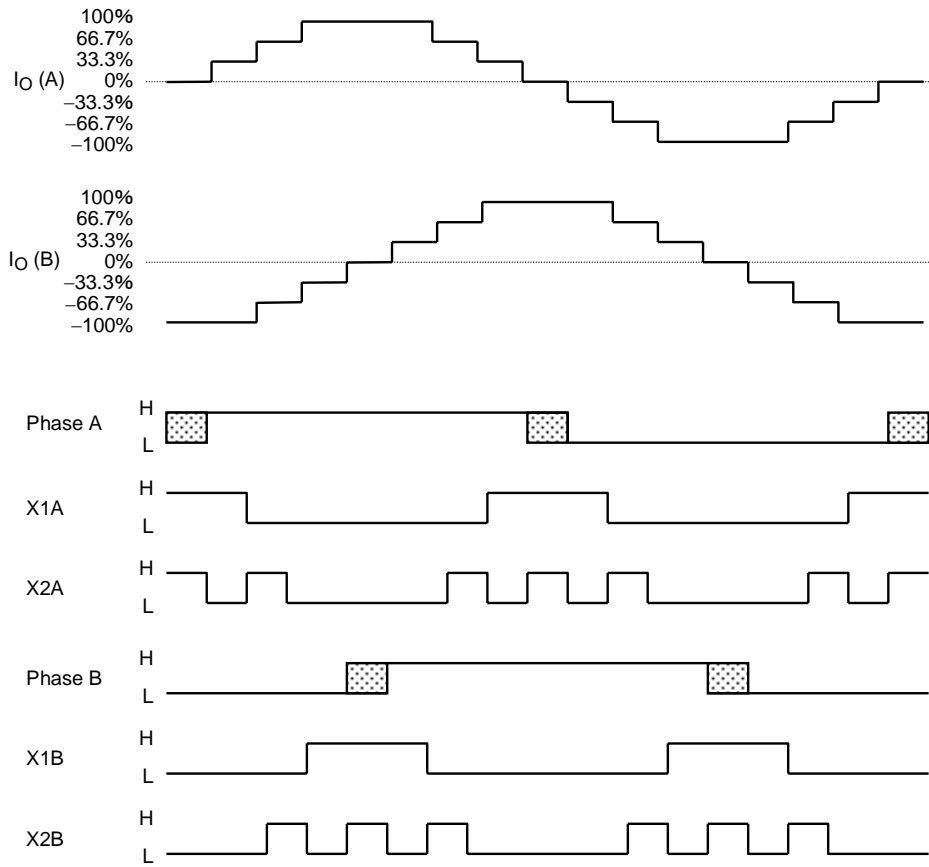



## PWM Current Control

The IC enters CW (CCW) mode and short brake mode alternately during PWM current control.

To prevent shoot-through current caused by simultaneous conduction of upper and lower transistors in the output stage, a dead time is internally generated for 500 ns (target spec) when the upper and lower transistors are being switched.

Therefore synchronous rectification for high efficiency in PWM current control can be achieved without an off-time generated via an external input.

Even when toggling between CW and CCW modes, and CW (CCW) and short brake modes, no off-time is required due to the internally generated dead time.

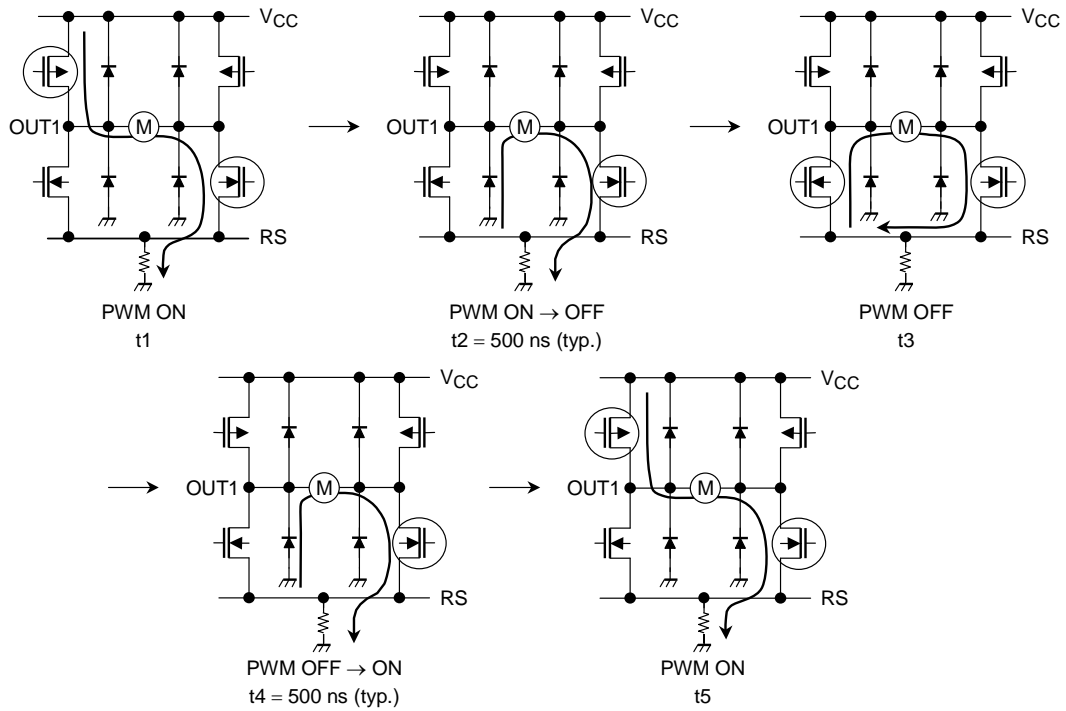

## (1) Constant current regulation

When  $V_{RS}$  reaches the reference voltage ( $V_{ref}$ ), the IC enters discharge mode. After four clock signals are generated from the oscillator, the IC moves from discharge mode to charge mode.

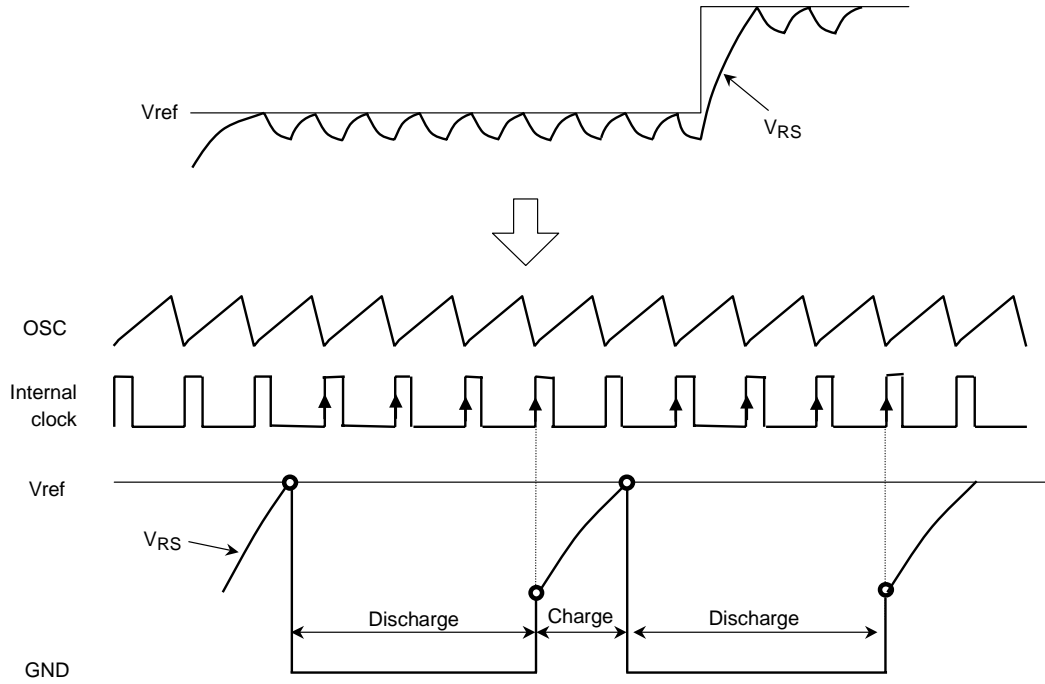

- (2) Transition from charge mode to discharge mode  
 If  $V_{RS} > V_{ref}$  after four clock signals in charge mode, the IC again enters discharge mode. After a further four clock signals in discharge mode,  $V_{RS}$  is compared with  $V_{ref}$ . If  $V_{RS} < V_{ref}$ , the IC operates in charge mode until  $V_{RS}$  reaches  $V_{ref}$ .

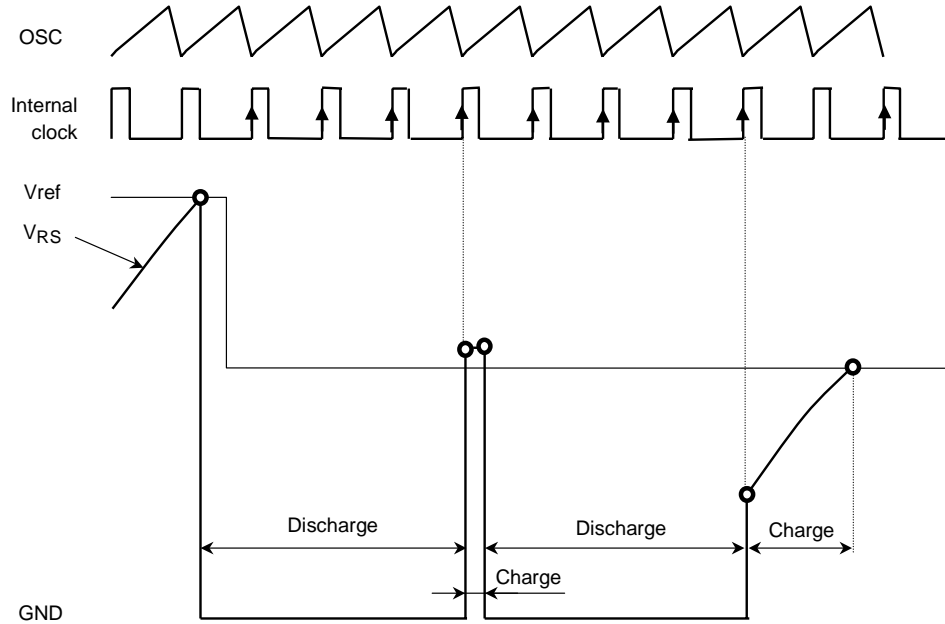

- (3) Transition from discharge mode to charge mode  
 Even when the reference voltage has risen, discharge mode lasts for four clock signals and is then toggled to charge mode.

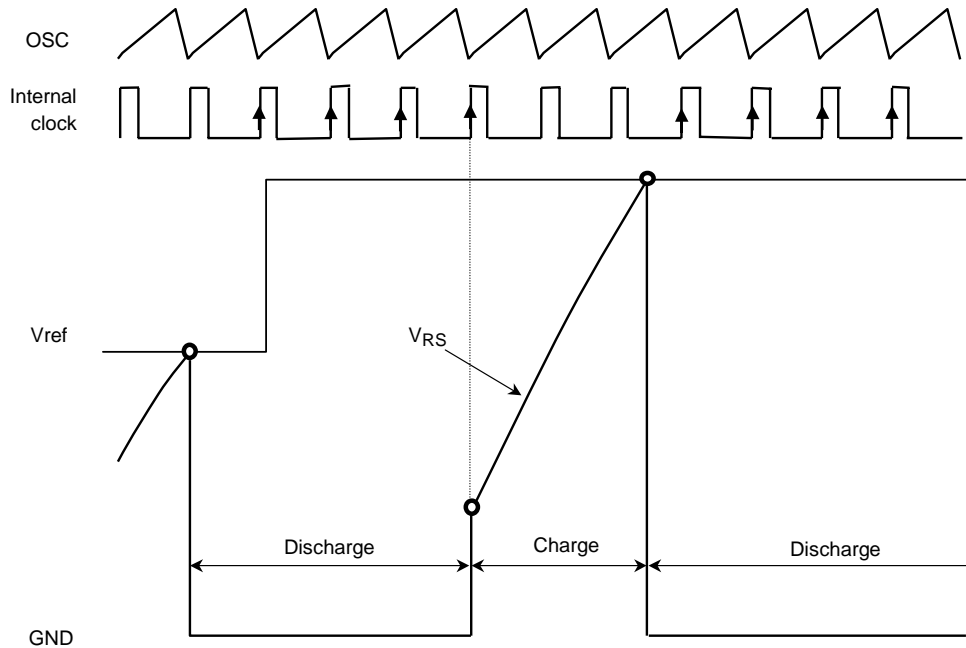

**Internal oscillation frequency (fosc)**

The internal oscillation frequency is determined by the charging and discharging of the external capacitor ( $C_{osc}$ ):

$$f_{osc} = 1 / (0.523 \times (C_{osc} \times 3700 + C_{osc} \times 600)) \quad (\text{theoretical formula})$$

## Reference Voltage Generator

The current value at 100% is determined by applying voltage at the Vref pin.

The value can be calculated as:

$$I_O (100\%) = V_{ref} \times 1/10 \times 1/R_S[A] \quad (X1 = X2 = L)$$

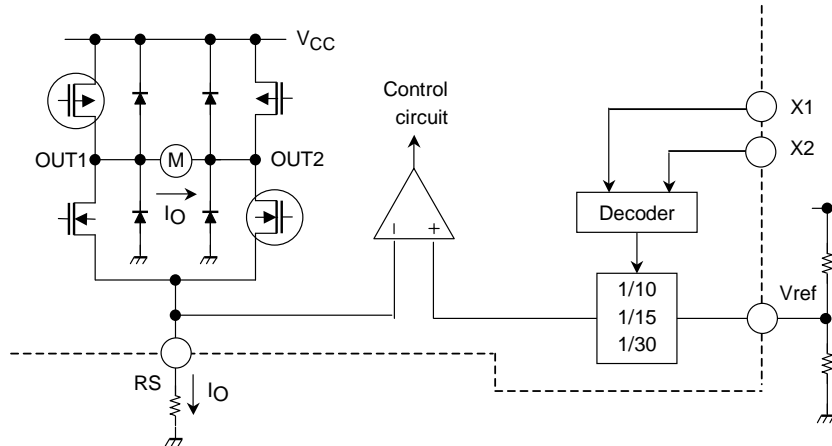

## Thermal Shutdown Circuit (TSD)

The IC incorporates a thermal shutdown circuit. When the junction temperature ( $T_j$ ) reaches 160°C (typ.), the output transistors are turned off.

After 50  $\mu$ s (typ.), the output transistors are turned on automatically.

The IC has 20°C of temperature hysteresis.

TSD = 160°C (target spec)

$\Delta$ TSD = 20°C (target spec)

## Overcurrent Protection Circuit (ISD)

The IC incorporates an overcurrent protection circuit to detect voltage flowing through the output transistors. The overcurrent threshold is 2.5 A (typ.).

Currents flowing through the output transistors are monitored individually. If overcurrent is detected in at least one of the transistors, all transistors are turned off.

The IC incorporates a timer to count the 50  $\mu$ s (typ.) for which the transistors are off. After the 50  $\mu$ s, the transistors are turned on automatically. If an overcurrent occurs again, the same operation is repeated. To prevent false detection due to glitches, the circuit turns off the transistors only when current exceeding the overcurrent threshold flows for 10  $\mu$ s or longer.

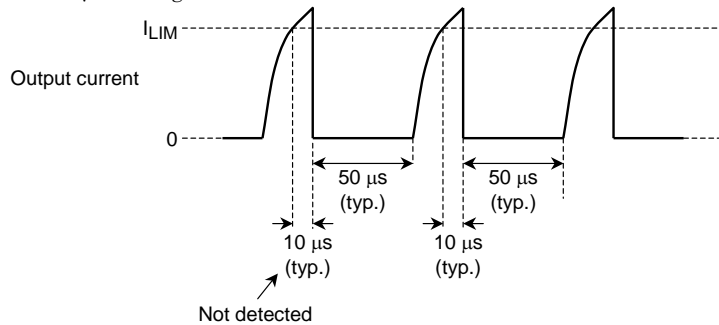

The target specification for the overcurrent limiter value (overcurrent threshold) is 2.5 A (typ.), and varies in a range from approximately 1.5 A to 3.5 A.

These protection functions are intended only as a temporary means of preventing output short circuits or other abnormal conditions and are not guaranteed to prevent damage to the IC.

- If the guaranteed operating ranges of this product are exceeded, these protection features may not operate and some output short circuits may result in the IC being damaged.

The overcurrent protection feature is intended to protect the IC from temporary short circuits only.

Short circuits persisting over long periods may cause excessive stress and damage the IC. Systems should be configured so that any overcurrent condition will be eliminated as soon as possible.

**Application Circuit**

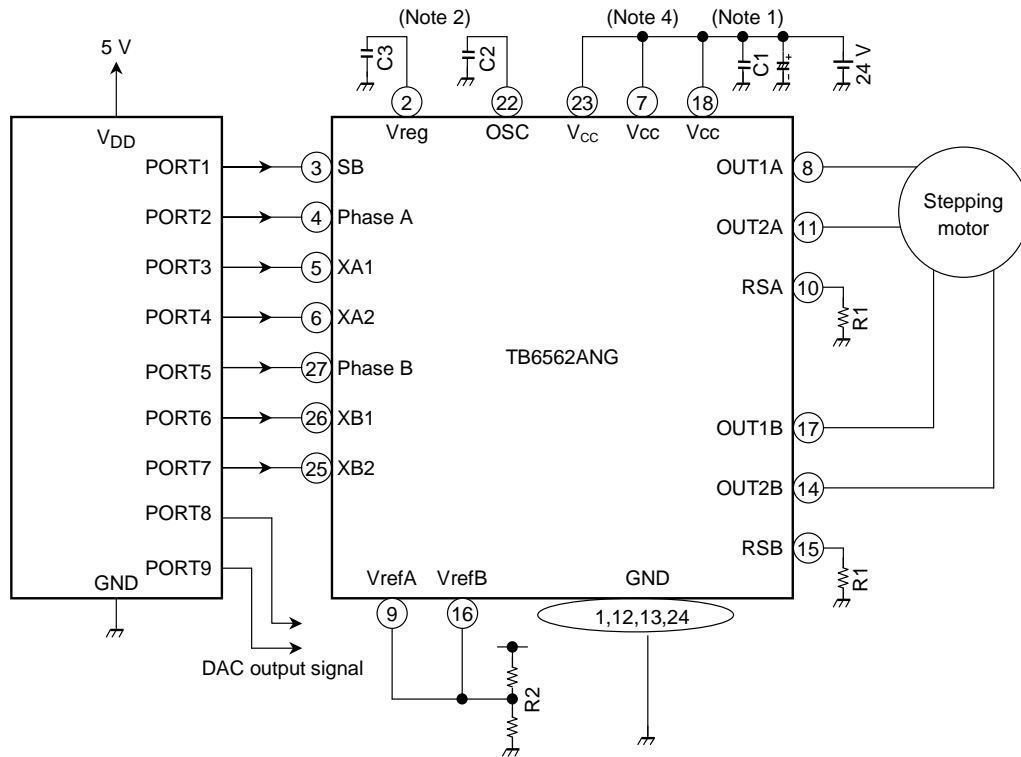

Note 1: A power supply capacitor should be connected between V<sub>CC</sub> and RSA (RSB) and as close as possible to the IC.

Note 2: C2 and C3 should be connected as close as possible to S-GND.

Note 3: When changing the V<sub>ref</sub>, a DAC output can be connected directly to the V<sub>ref</sub> pin.

Note 4: The V<sub>CC</sub> pins (pin 23, pin 7, pin 18) should be shorted externally.

**Caution on Use**

- The IC may be destroyed by short circuits between output pins, an output pin and the V<sub>CC</sub> pin, or an output pin and the ground pin. Exercise due care when designing output lines, V<sub>CC</sub> lines and ground lines.
- Install the product correctly. Otherwise, breakdown, damage and/or degradation to the product or equipment may result.

SDIP24-P-300-1.78

Unit : mm

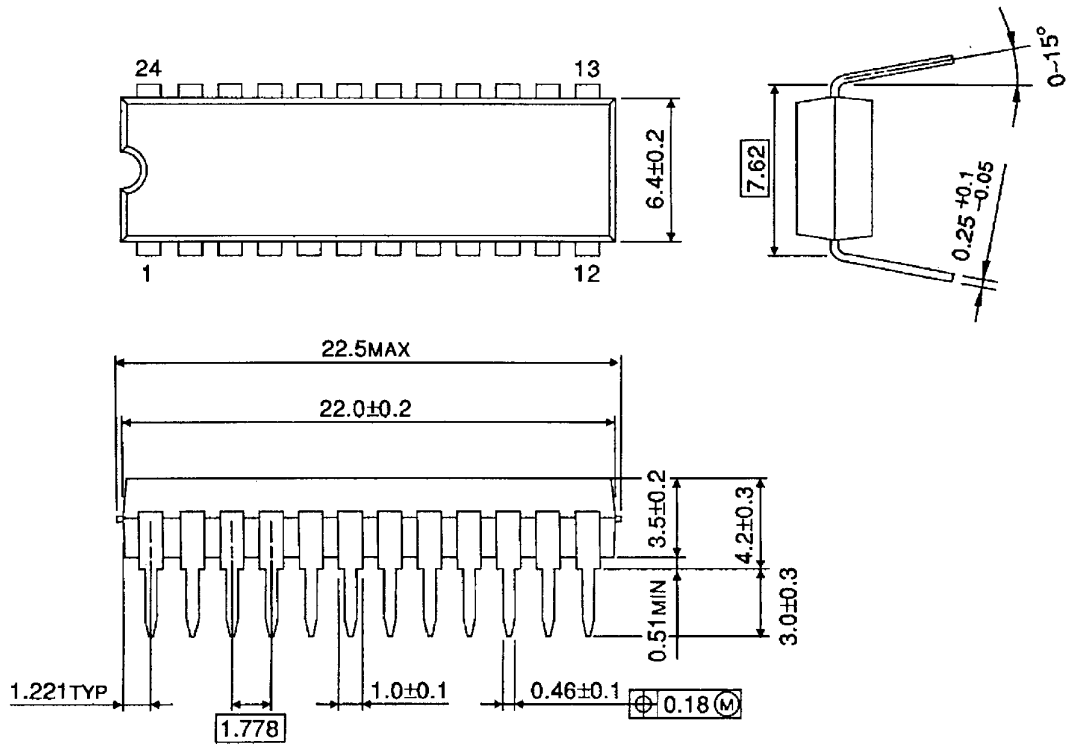

Weight: 1.62 g (typ.)

## Notes on contents

### 1. Block Diagrams

Some of the functional blocks, circuits, or constants in the block diagram may be omitted or simplified for explanatory purposes.

### 2. Equivalent Circuits

The equivalent circuit diagrams may be simplified or some parts of them may be omitted for explanatory purposes.

### 3. Timing Charts

Timing charts may be simplified for explanatory purposes.

### 4. Maximum Ratings

The absolute maximum ratings of a semiconductor device are a set of specified parameter values that must not be exceeded during operation, even for an instant.

If any of these ratings are exceeded during operation, the electrical characteristics of the device may be irreparably altered, in which case the reliability and lifetime of the device can no longer be guaranteed.

Moreover, any exceeding of the ratings during operation may cause breakdown, damage and/or degradation in other equipment. Applications using the device should be designed so that no maximum rating will ever be exceeded under any operating conditions.

Before using, creating and/or producing designs, refer to and comply with the precautions and conditions set forth in this document.

### 5. Application Circuits

The application circuits shown in this document are provided for reference purposes only. Thorough evaluation is required in the mass production design phase.

In furnishing these examples of application circuits, Toshiba does not grant the use of any industrial property rights.

### 6. Test Circuits

Components in test circuits are used only to obtain and confirm device characteristics. These components and circuits are not guaranteed to prevent malfunction or failure in application equipment.

## Handling of the IC

Ensure that the product is installed correctly to prevent breakdown, damage and/or degradation in the product or equipment.

## Overcurrent protection and heat protection circuits

These protection functions are intended only as a temporary means of preventing output short circuits or other abnormal conditions and are not guaranteed to prevent damage to the IC.

If the guaranteed operating ranges of this product are exceeded, these protection features may not operate and some output short circuits may result in the IC being damaged.

The overcurrent protection feature is intended to protect the IC from temporary short circuits only.

Short circuits persisting over long periods may cause excessive stress and damage the IC. Systems should be configured so that any overcurrent condition will be eliminated as soon as possible.

## Counter-electromotive force

When the motor reverses or stops, the effect of counter-electromotive force may cause the current to flow to the power source.

If the power supply is not equipped with sink capability, the power and output pins may exceed the maximum rating.

The counter-electromotive force of the motor will vary depending on the conditions of use and the features of the motor. Therefore make sure there will be no damage to or operational problem in the IC, and no damage to or operational errors in peripheral circuits caused by counter-electromotive force.

**RESTRICTIONS ON PRODUCT USE**

030619EBA

- The information contained herein is subject to change without notice.
- The information contained herein is presented only as a guide for the applications of our products. No responsibility is assumed by TOSHIBA for any infringements of patents or other rights of the third parties which may result from its use. No license is granted by implication or otherwise under any patent or patent rights of TOSHIBA or others.
- TOSHIBA is continually working to improve the quality and reliability of its products. Nevertheless, semiconductor devices in general can malfunction or fail due to their inherent electrical sensitivity and vulnerability to physical stress. It is the responsibility of the buyer, when utilizing TOSHIBA products, to comply with the standards of safety in making a safe design for the entire system, and to avoid situations in which a malfunction or failure of such TOSHIBA products could cause loss of human life, bodily injury or damage to property.  
In developing your designs, please ensure that TOSHIBA products are used within specified operating ranges as set forth in the most recent TOSHIBA products specifications. Also, please keep in mind the precautions and conditions set forth in the "Handling Guide for Semiconductor Devices," or "TOSHIBA Semiconductor Reliability Handbook" etc..
- The TOSHIBA products listed in this document are intended for usage in general electronics applications (computer, personal equipment, office equipment, measuring equipment, industrial robotics, domestic appliances, etc.). These TOSHIBA products are neither intended nor warranted for usage in equipment that requires extraordinarily high quality and/or reliability or a malfunction or failure of which may cause loss of human life or bodily injury ("Unintended Usage"). Unintended Usage include atomic energy control instruments, airplane or spaceship instruments, transportation instruments, traffic signal instruments, combustion control instruments, medical instruments, all types of safety devices, etc.. Unintended Usage of TOSHIBA products listed in this document shall be made at the customer's own risk.
- The products described in this document are subject to the foreign exchange and foreign trade laws.
- TOSHIBA products should not be embedded to the downstream products which are prohibited to be produced and sold, under any law and regulations.