



**TRANSCOM**

**TC1101**

January 2002

**Low Noise and Medium Power GaAs FETs**

**FEATURES**

- Low Noise Figure:  
NF = 0.5 dB Typical at 12 GHz
- High Associated Gain:  
Ga = 12 dB Typical at 12 GHz
- High Dynamic Range:  
1 dB Compression Power  $P_{-1}$  = 18 dBm at 12 GHz
- Breakdown Voltage:  $BV_{DGO} \geq 9$  V
- $L_g = 0.25 \mu\text{m}$ ,  $W_g = 160 \mu\text{m}$
- All-Gold Metallization for High Reliability
- 100 % DC Tested

**PHOTO ENLARGEMENT**

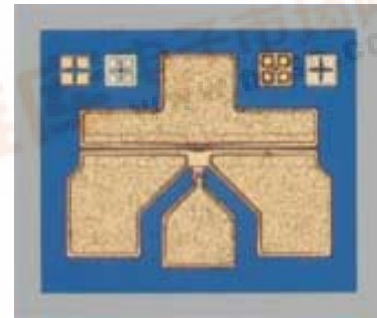

**DESCRIPTION**

The TC1101 is a GaAs Pseudomorphic High Electron Mobility Transistor (PHEMT) chip, which has very low noise figure, high associated gain and high dynamic range. The device can be used in circuits up to 40 GHz and suitable for low noise and medium power amplifier applications including a wide range of commercial and military applications. All devices are 100% DC tested to assure consistent quality. All bond pads are gold plated for either thermo-compression or thermo-sonic wire bonding.

**ELECTRICAL SPECIFICATIONS ( $T_A=25^\circ\text{C}$ )**

Symbol	Conditions	MIN	TYP	MAX	UNIT
NF	Noise Figure at $V_{DS} = 2$ V, $I_{DS} = 10$ mA, $f = 12$ GHz		0.5	0.7	dB
$G_a$	Associated Gain at $V_{DS} = 2$ V, $I_{DS} = 10$ mA, $f = 12$ GHz	10	12		dB
$P_{1dB}$	Output Power at 1dB Gain Compression Point, $f = 12$ GHz $V_{DS} = 4$ V, $I_{DS} = 25$ mA	17	18		dBm
$G_L$	Linear Power Gain, $f = 12$ GHz $V_{DS} = 4$ V, $I_{DS} = 25$ mA	12	14		dB
$I_{DSS}$	Saturated Drain-Source Current at $V_{DS} = 2$ V, $V_{GS} = 0$ V		40		mA
$g_m$	Transconductance at $V_{DS} = 2$ V, $V_{GS} = 0$ V		55		mS
$V_p$	Pinch-off Voltage at $V_{DS} = 2$ V, $I_D = 0.32$ mA		-1.0		Volts
$BV_{DGO}$	Drain-Gate Breakdown Voltage at $I_{DGO} = 0.08$ mA	9	12		Volts
$R_{th}$	Thermal Resistance		90		$^\circ\text{C}/\text{W}$



# TC1101

## ABSOLUTE MAXIMUM RATINGS ( $T_A=25\text{ }^\circ\text{C}$ )

Symbol	Parameter	Rating
$V_{DS}$	Drain-Source Voltage	7.0 V
$V_{GS}$	Gate-Source Voltage	-3.0 V
$I_{DS}$	Drain Current	$I_{DSS}$
$I_{GS}$	Gate Current	160 $\mu\text{A}$
$P_{in}$	RF Input Power, CW	14 dBm
$P_T$	Continuous Dissipation	150 mW
$T_{CH}$	Channel Temperature	175 $^\circ\text{C}$
$T_{STG}$	Storage Temperature	- 65 $^\circ\text{C}$ to +175 $^\circ\text{C}$

## TYPICAL NOISE PARAMETERS ( $T_A=25\text{ }^\circ\text{C}$ )

$V_{DS} = 2\text{ V}$ ,  $I_{DS} = 10\text{ mA}$

Frequency (GHz)	$NF_{opt}$ (dB)	$G_A$ (dB)	$\Gamma_{opt}$		Rn/50
			MAG	ANG	
2	0.38	19.8	0.99	4	1.52
4	0.40	17.5	0.90	9	1.05
6	0.42	15.6	0.82	18	0.77
8	0.45	13.9	0.76	29	0.61
10	0.50	13.1	0.69	43	0.51
12	0.55	12.4	0.63	55	0.44
14	0.64	11.7	0.56	65	0.37
16	0.78	11.1	0.45	76	0.30
18	0.95	10.6	0.34	90	0.24

## CHIP DIMENSIONS

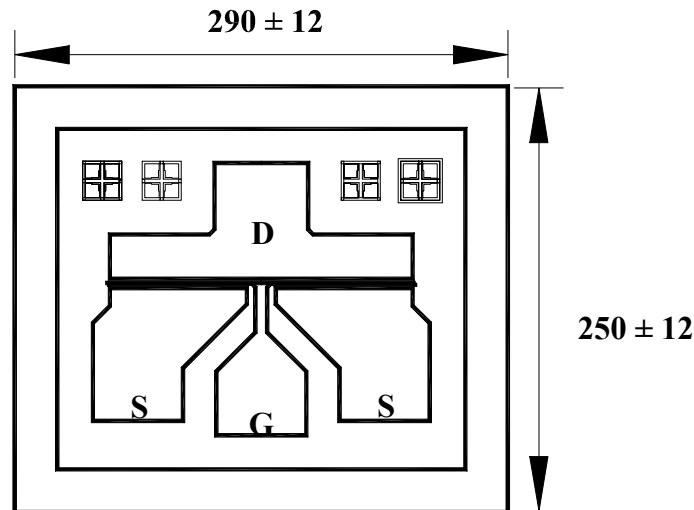

Units: Micrometers  
Chip Thickness: 100

Gate Pad: 55 x 50  
Drain Pad: 55 x 50  
Source Pad: 55 x 60



### TYPICAL SCATTERING PARAMETERS ( $T_A=25\text{ }^\circ\text{C}$ )

$V_{DS} = 2\text{ V}$ ,  $I_{DS} = 10\text{ mA}$

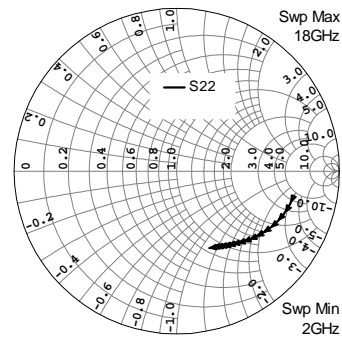
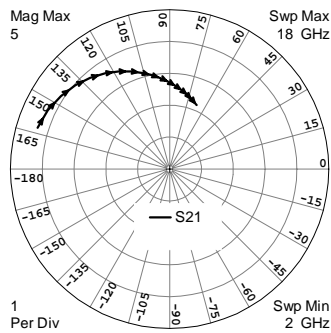
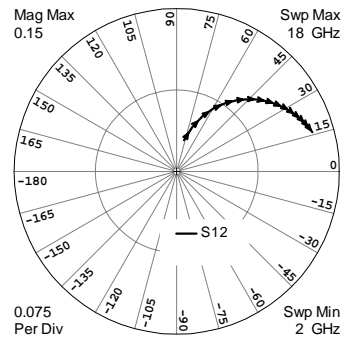
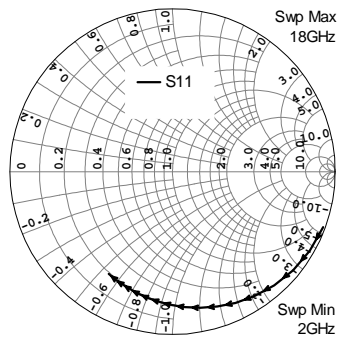

FREQUENCY (GHz)	S11		S21		S12		S22	
	MAG	ANG	MAG	ANG	MAG	ANG	MAG	ANG
2	0.9879	-20.21	4.3485	162.66	0.0296	77.08	0.7367	-11.76
3	0.9740	-29.96	4.2452	154.28	0.0434	70.91	0.7235	-17.37
4	0.9564	-39.31	4.1126	146.20	0.0560	65.04	0.7068	-22.68
5	0.9364	-48.20	3.9594	138.48	0.0674	59.53	0.6877	-27.66
6	0.9152	-56.56	3.7943	131.15	0.0774	54.40	0.6676	-32.28
7	0.8939	-64.40	3.6242	124.22	0.0861	49.66	0.6472	-36.54
8	0.8732	-71.72	3.4546	117.66	0.0937	45.29	0.6276	-40.46
9	0.8536	-78.52	3.2894	111.45	0.1002	41.27	0.6090	-44.06
10	0.8354	-84.84	3.1312	105.57	0.1058	37.57	0.5919	-47.37
11	0.8188	-90.72	2.9813	99.99	0.1106	34.16	0.5764	-50.43
12	0.8037	-96.18	2.8406	94.68	0.1148	31.00	0.5627	-53.28
13	0.7901	-101.25	2.7092	89.60	0.1183	28.08	0.5506	-55.93
14	0.7780	-105.98	2.5868	84.74	0.1214	25.36	0.5402	-58.41
15	0.7671	-110.39	2.4731	80.07	0.1241	22.82	0.5313	-60.76
16	0.7575	-114.51	2.3676	75.57	0.1264	20.44	0.5239	-62.99
17	0.7491	-118.37	2.2697	71.21	0.1284	18.20	0.5179	-65.12
18	0.7416	-121.99	2.1788	66.99	0.1302	16.08	0.5132	-67.16

• The data does not include gate, drain and source bond wires.

# TC1101

## TYPICAL SCATTERING PARAMETERS (T<sub>A</sub>=25 °C)

V<sub>DS</sub> = 4 V, I<sub>DS</sub> = 25 mA

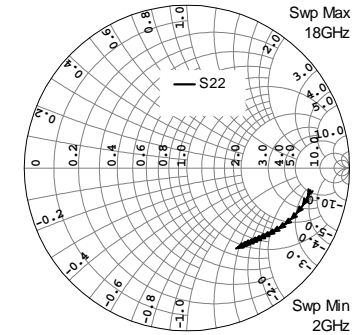
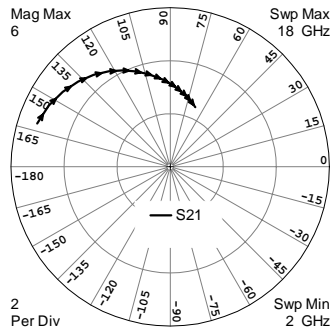
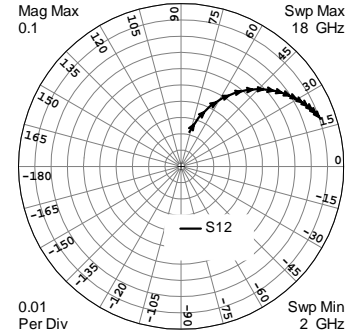
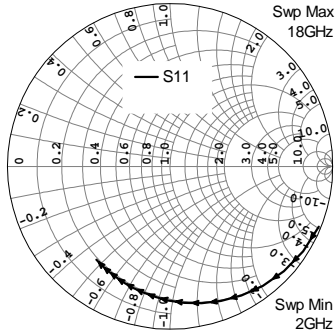

FREQUENCY (GHz)	S11		S21		S12		S22	
	MAG	ANG	MAG	ANG	MAG	ANG	MAG	ANG
2	0.9861	-22.03	5.2729	161.97	0.0218	76.68	0.7718	-10.24
3	0.9704	-32.59	5.1264	153.31	0.0318	70.37	0.7586	-15.08
4	0.9507	-42.66	4.9406	145.03	0.0408	64.44	0.7422	-19.62
5	0.9288	-52.16	4.7291	137.18	0.0488	58.94	0.7239	-23.82
6	0.9059	-61.05	4.5045	129.78	0.0558	53.89	0.7050	-27.69
7	0.8834	-69.32	4.2765	122.83	0.0618	49.28	0.6865	-31.23
8	0.8618	-76.97	4.0524	116.31	0.0669	45.10	0.6690	-34.49
9	0.8418	-84.05	3.8370	110.19	0.0712	41.30	0.6530	-37.49
10	0.8234	-90.59	3.6330	104.41	0.0749	37.85	0.6386	-40.28
11	0.8068	-96.63	3.4418	98.96	0.0781	34.72	0.6260	-42.90
12	0.7919	-102.23	3.2639	93.79	0.0807	31.86	0.6150	-45.37
13	0.7786	-107.40	3.0990	88.86	0.0830	29.24	0.6057	-47.73
14	0.7668	-112.21	2.9466	84.16	0.0850	26.83	0.5978	-49.99
15	0.7564	-116.69	2.8058	79.65	0.0867	24.60	0.5913	-52.18
16	0.7471	-120.86	2.6758	75.31	0.0882	22.54	0.5861	-54.32
17	0.7389	-124.76	2.5557	71.12	0.0895	20.62	0.5821	-56.41
18	0.7316	-128.41	2.4446	67.06	0.0906	18.82	0.5790	-58.46

• The data does not include gate, drain and source bond wires.



**SMALL SIGNAL MODEL,  $V_{DS} = 2\text{ V}$ ,  $I_{DS} = 10\text{ mA}$**

**SCHEMATIC**

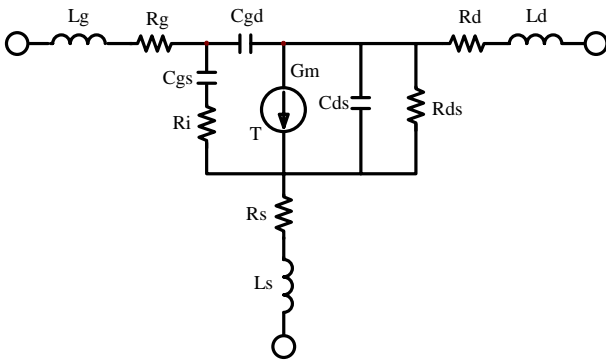

**PARAMETERS**

Parameters		Parameters	
<b>Lg</b>	0.04708 nH	<b>Rs</b>	1.29 Ohm
<b>Rg</b>	1.46 Ohm	<b>Ls</b>	0.001 nH
<b>Cgs</b>	0.207 pF	<b>Cds</b>	0.0684 pF
<b>Ri</b>	3.68 Ohm	<b>Rds</b>	321.5 Ohm
<b>Cgd</b>	0.0269 pF	<b>Rd</b>	1.525 Ohm
<b>Gm</b>	54.8 mS	<b>Ld</b>	0.0379 nH
<b>T</b>	3.34 psec		

**SMALL SIGNAL MODEL,  $V_{DS} = 4\text{ V}$ ,  $I_{DS} = 25\text{ mA}$**

**SCHEMATIC**

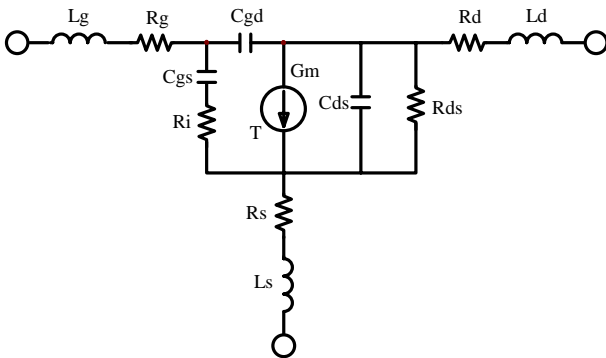

**PARAMETERS**

Parameters		Parameters	
<b>Lg</b>	0.04708 nH	<b>Rs</b>	1.25 Ohm
<b>Rg</b>	1.46 Ohm	<b>Ls</b>	0.001 nH
<b>Cgs</b>	0.254 pF	<b>Cds</b>	0.0666 pF
<b>Ri</b>	5.91 Ohm	<b>Rds</b>	377.8 Ohm
<b>Cgd</b>	0.0192 pF	<b>Rd</b>	1.525 Ohm
<b>Gm</b>	66.0 mS	<b>Ld</b>	0.0379 nH
<b>T</b>	3.64 psec		

# TC1101

---

## CHIP HANDLING

**DIE ATTACHMENT:** Conductive epoxy or eutectic die attach is recommended. Eutectic die attach can be accomplished with Au-Sn (80% Au-20%Sn) perform at stage temperature:  $290^{\circ}\text{C} \pm 5^{\circ}\text{C}$ ; Handling Tool: Tweezers; Time: less than 1min.

**WIRE BONDING:** The recommended wire bond method is thermocompression bonding with 0.7 to 1.0 mil (0.018 to 0.025 mm) gold wire. Stage temperature:  $220^{\circ}\text{C}$  to  $250^{\circ}\text{C}$ ; Bond Tip Temperature:  $150^{\circ}\text{C}$ ; Bond Force: 20 to 30 gms depending on size of wire and Bond Tip Temperature.

**HANDLING PRECAUTIONS:** The user must operate in a clean, dry environment. Care should be exercised during handling avoid damage to the devices. Electrostatic Discharge (ESD) precautions should be observed at all stages of storage, handling, assembly, and testing. The static discharge must be less than 300V.